



LIVE THE BRAAI LIFE

## CARRI CHEF 2

MODEL No: 8910  
28mBar & 50mBar



# USER INSTRUCTIONS

GB DE DK ES FR IT NL NO PL SE SI

NOTE! PRODUCT MAY VARY FROM ILLUSTRATIONS

503-0320 LEV27

**CAUTION**  
For Outdoor use only!

This appliance may not be used in an exterior enclosed balcony, porch or entertainment area!

**IMPORTANT**

Read these instructions for use carefully so as to familiarize yourself with the appliance before connecting it to its gas container. Keep these instructions for future reference.

## 1. Introduction

- This appliance has been designed to be used for outdoor cooking, specifically for people who go camping to enjoy outdoor life and can also be used on a patio.
- Various food types can be prepared on this appliance. The Carri Chef 2 is designed to utilise various cooking surfaces.
- Gas is supplied to the unit via a hose and regulator. The hose and regulator can be connected to gas cylinder, a gas cartridge, a CADAC Power Pak 1000 which is a unit that takes two gas cartridges or a Vertical EN417 Regulator assembly connected to a EN417 threaded gas cartridge. (Not supplied with the appliance).
- The unit is easy to switch on, and to operate (Described below in section 6) and the user can control the heat input with an adjustable valve.
- A recipe book is supplied with this appliance to give the first time user an introduction to outdoor cooking options.

## 2. General information

- This appliance complies with EN498:2012, EN484:1997 and SANS 1539:2012
- This appliance may only be used with an approved hose and regulator (hose and regulator supplied with this unit in South Africa)
- **Warning:** Accessible parts may be very hot. Keep young children away.
- The Powerpak 1000 / Refillable cylinder / Vertical EN417 Regulator assembly is to be used only in the upright position. (Optional accessory-not supplied).
- **Note:** To ensure satisfactory operation when using a PowerPak 1000 always start up with full cartridges and only when the intended period of continuous operation is less than approximately one hour.
- Only to be used with a gas cylinder that does not exceed 500mm in height.
- Gas appliances require ventilation for efficient performance and to ensure the safety of users and other persons in close proximity, therefor do not use the appliance in an unventilated area. It is intended for use outdoors only.
- Read these instructions carefully before using the appliance.
- **Use outdoors only!**

<b>Country of Use</b>	BE, CH, CY, CZ, ES, FR, GB, GR, IE, IT, LT, LU, LV, PT, SK & SI	PL	BE, CY, DK, EE, FR, FI, HU, IT, LT, NL, NO, SE, SI, SK, RO, HR, TR, BG, IS, LU, MT, & ZA	AT, CH, DE & SK	
<b>Appliance Catagories</b>	I <sub>3+</sub> (28-30/37)		I <sub>3B/P</sub> (37)	I <sub>3B/P</sub> (30)	I <sub>3B/P</sub> (50)
<b>Allowable gasses</b>	Butane	Propane	Butane, Propane or their mixture		
<b>Gas Pressure</b>	28-30mBar	37mBar	37mBar	28-30mBar (2.8kPa for South Africa)	50mBar
<b>Jet Number</b>	0.92				0.82
<b>Nominal Usage</b>	270g/hr		313g/hr	270g/hr	270g/hr
<b>Gross nom. heat input</b>	3.7kW		4.3kW	3.7kW	3.7kW

<b>Gas Supply Sources</b>	An approved hose and regulator connected to a refillable gas container not exceeding 9kg and complying with local regulation in force
---------------------------	---

Country Name and Abbreviations				
AE = United Arab Emirates	AL = Albania	AT = Austria	BE = Belgium	CH = Switzerland
CZ = Czech Republic	DE = Germany	DK = Denmark	ES = Spain	FI = Finland
FR = France	GB = United Kingdom	GR = Greece	HR = Croatia	IT = Italy
JP = Japan	KR = Korea	NL = Netherlands	NO = Norway	PL = Poland
PT = Portugal	RO = Romania	RU = Russia	RS = Serbia	SI = Slovenia
SK = Slovakia	SE = Sweden	TR = Turkey	ZA = South Africa	

### 3. Safety Information

#### Hose

- This appliance may only be used outdoors.
- A hose and regulator is supplied with this appliance (South Africa Only)
- The hose must be checked for wear or damage before every use and before connecting to the gas container.
- Do not use the appliance if it has a damaged or worn hose. Replace the hose.
- Do not use the appliance if it is leaking, damaged or which does not operate properly.

#### Gas Container

- Only use a cylinder that is approved by your countries regulations.
- Ensure that the gas container is fitted or changed in a well-ventilated location, preferably outdoors, away from any sources of ignition such as naked flames, pilots, electric fires and away from other people.
- Keep gas containers away from heat and flame. Do not place on a stove or any other hot surface.
- Gas cartridges/refillable cylinders are to be used only in the upright position so as to ensure proper fuel withdrawal. Failure to adhere to this may cause liquid discharge from the gas container resulting in a dangerous operating condition.
- Do not try to remove the cylinder whilst the unit is in operation.
- A space has been provided in the centre of the utility tray to place a gas cartridge into.
- The gas cylinder must be disconnected from the appliance after use or when in storage.

#### Assembly and use

- The appliance is designed to be portable, therefore the legs and the utility tray is easily removable / assembled the ease of transport and use.
- User assembly / dis-assembly is limited to the fitment of the legs, utility tray, and the installation / removal of cooking surfaces.
- When assembling the legs, always make sure that the leg securing rings have been securely fastened and that the assembled product is stable and does not rock. Do not use the appliance without fitting the Accessories Tray as it also plays an important role in ensuring the overall sturdiness of the appliance.
- Use only on a firm level surface.
- Do not move the appliance whilst the unit is in operation.
- Should the Heat Shield, Fat Pan or Burner Pan become damaged in such a way that permanent contact between the Heat Shield and the Fat Pan occurs during use, do not use the appliance. Return it to your Cadac stockist for repair.
- Do not cover up or change the Air Holes in the Valve Box Cover as this will affect the performance of the product and may lead to an unstable flame.
- Ensure the appliance is used away from flammable materials. Minimum safe distances are: Above the appliance 1.2m. At the rear and sides 600mm. (See Fig. 2)
- **Caution:** When using the appliance, we recommend the use of protective gloves when removing and applying the dome, as the dome handle may become hot.
- **Caution:** Accessible parts may become very hot, the use of protective gloves is recommended.
- Keep young children away from the appliance.
- **Use Outdoors Only**
- **NOTE!** If the appliance is used in windy conditions, the dome must be used as a wind shield, and placed in position as shown in Fig. 4.

#### Light back

- In the event of light back (where the flame burns back and ignites inside the burner or venturi housing), immediately turn off the gas supply by firstly closing the control valve on the gas container and then the appliance valve. After the flame is extinguished, remove the regulator and check the condition of the seal; replace the seal if in doubt. Re-light the appliance as described in Section 6 below. Should the flame persistently light back, return the product to your authorised CADAC repair agent.

#### Leaks

- If there is a leak on your appliance (smell of gas), immediately close the control knob on the gas cylinder. If you wish to check for leaks on your appliance, do it outside. Do not try to detect leaks using a flame; use soapy water.
- The correct way is to smear the joints with soapy water. If a bubble or bubbles form then there is a gas leak. Immediately turn off the gas supply firstly by closing the control valve on the gas container and then the appliance valve. Check that all the connections are properly fitted. Re-check with soapy water. If a gas leak persists, return the product to your CADAC dealer for inspection / repair.
- Check for leaks on the tailpiece by the valve and on the cylinder regulator fitting with gas open on cylinder but not open or switched on by the appliance control knob.

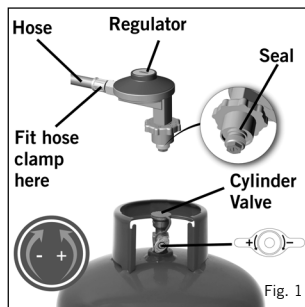

Fig. 1

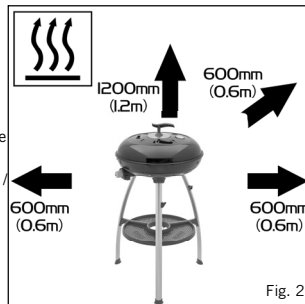

Fig. 2

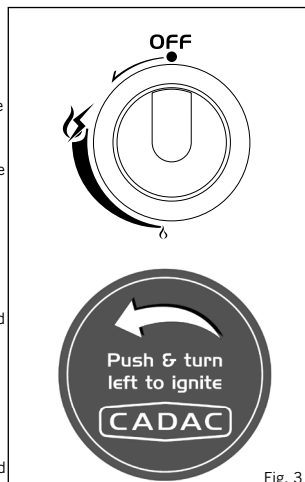

Fig. 3

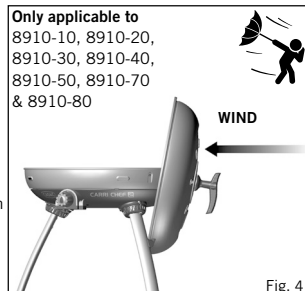

Fig. 4

## 4. Combos

### Carri Chef 2 Skottel Combo 1 (Product Code: 8910-10)

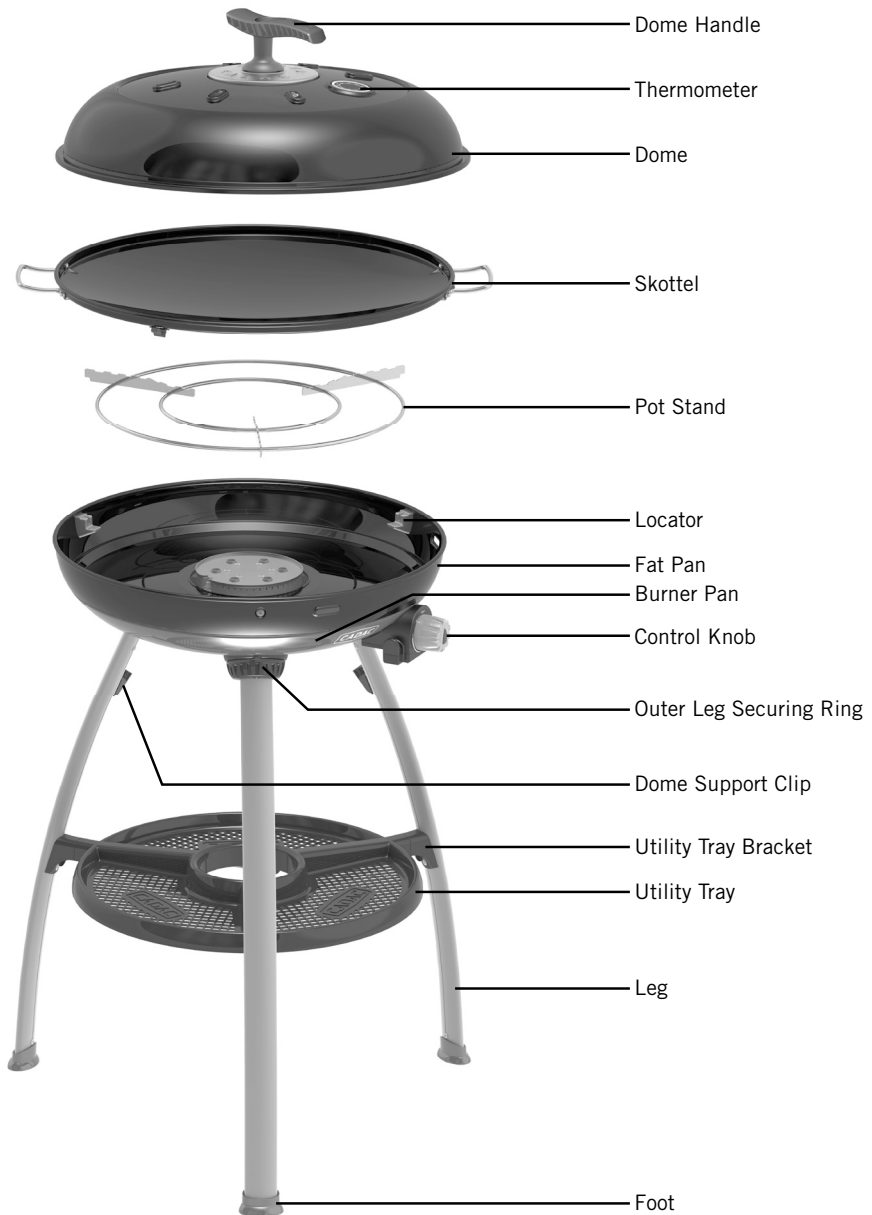

Fig. 5a

## 4. Combos

### Carri Chef 2 Skottel Combo 2 (Product Code: 8910-11)

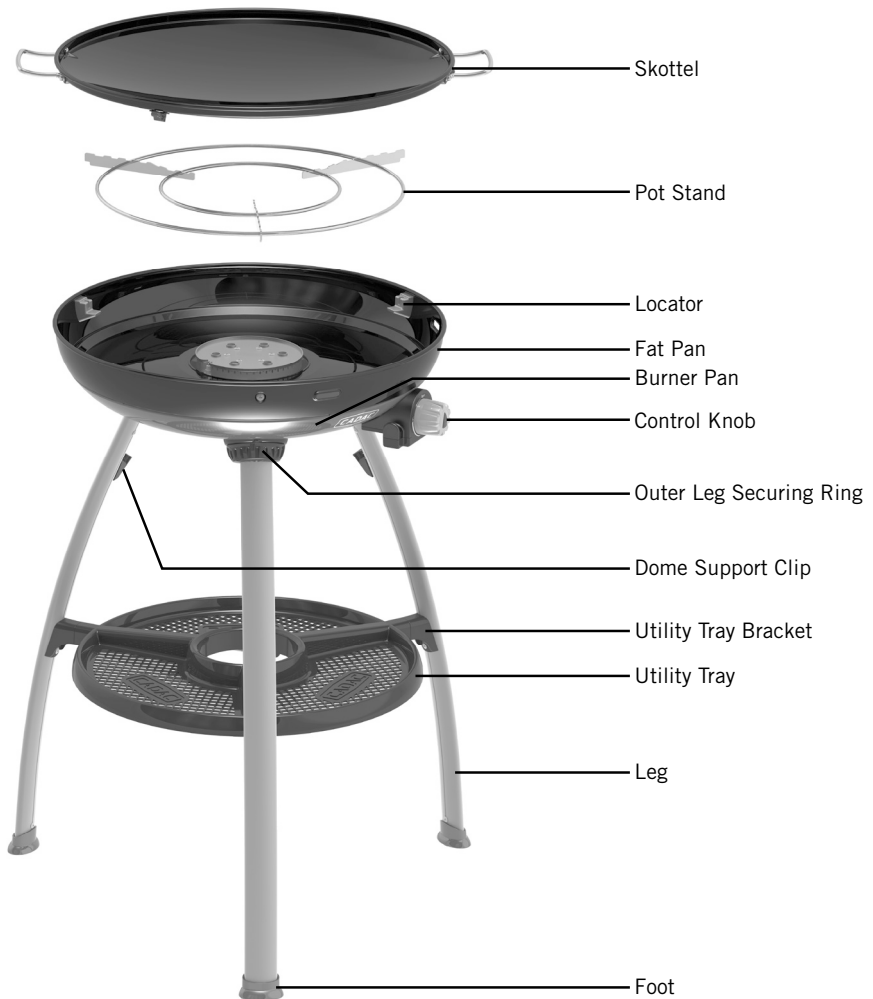

Fig. 5b

## 4. Combos

### Carri Chef 2 BBQ Combo 1 (Product Code: 8910-20)

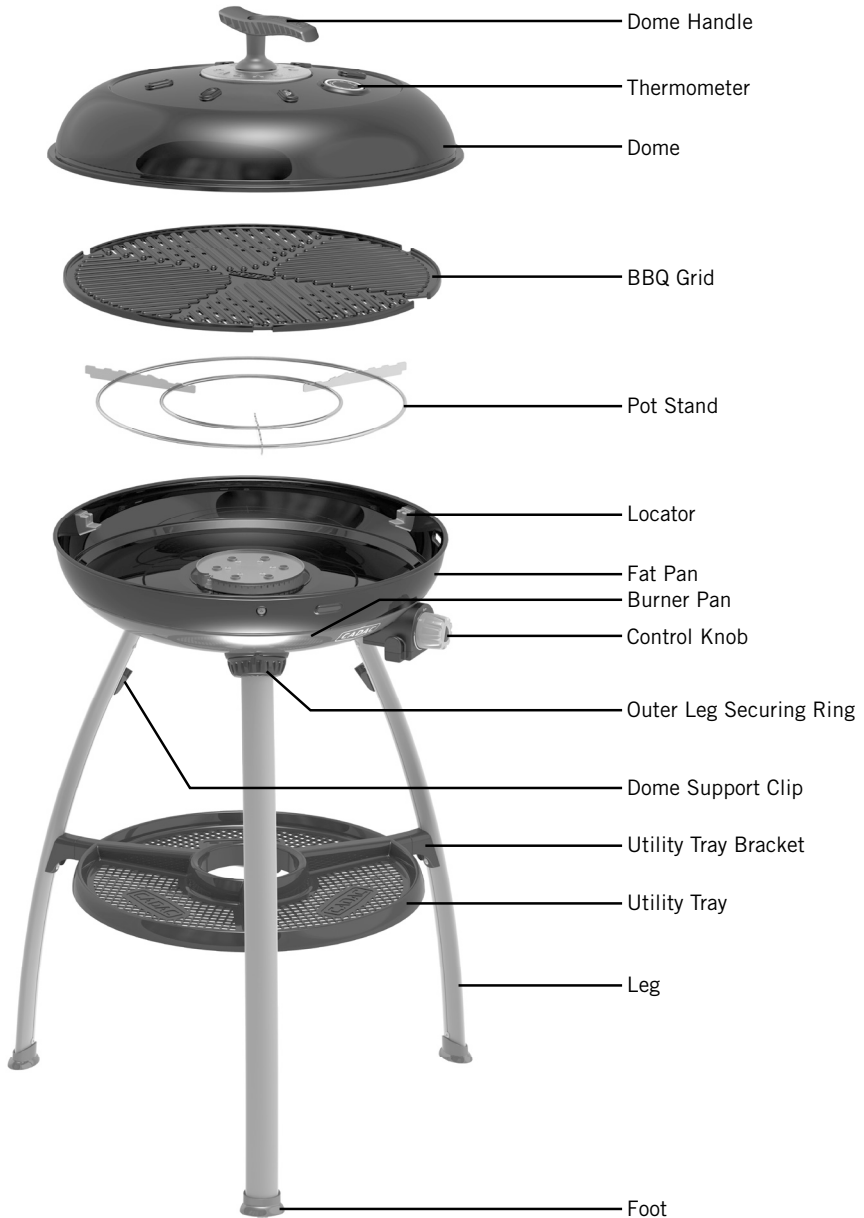

Fig. 6a

## 4. Combos

### Carri Chef 2 BBQ Combo 2 (Product Code: 8910-21)



Fig. 6b

## 4. Combos

### Carri Chef 2 BBQ / Skottel Combo (Product Code 8910-30)



Fig. 7

## 4. Combos

### Carri Chef 2 BBQ / Chef Pan Combo (Product Code: 8910-40)



Fig. 8

## 4. Combos

Carri Chef 2 BBQ / Grill  Braai-Combo 1 (Product Code 8910-50)

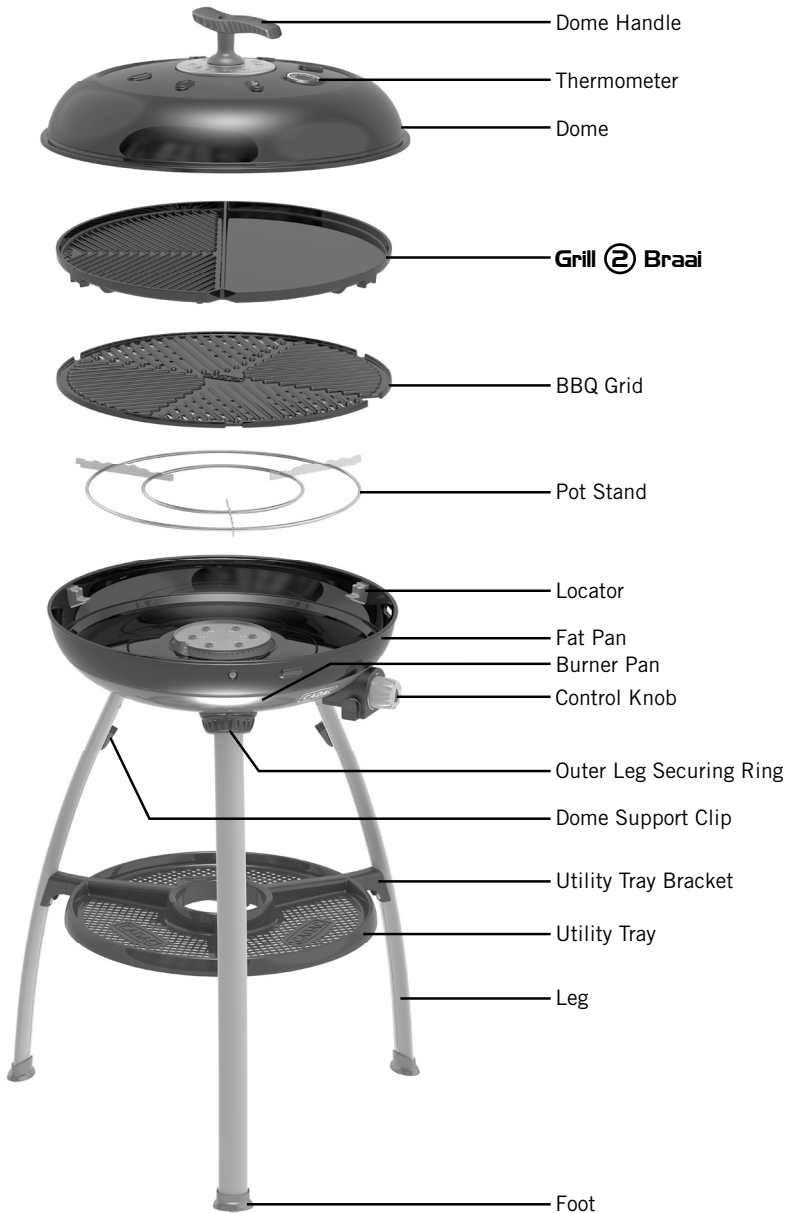

Fig. 9a

## 4. Combos

Carri Chef 2 BBQ / Grill (2) Braai-Combo 2 (Product Code 8910-51)

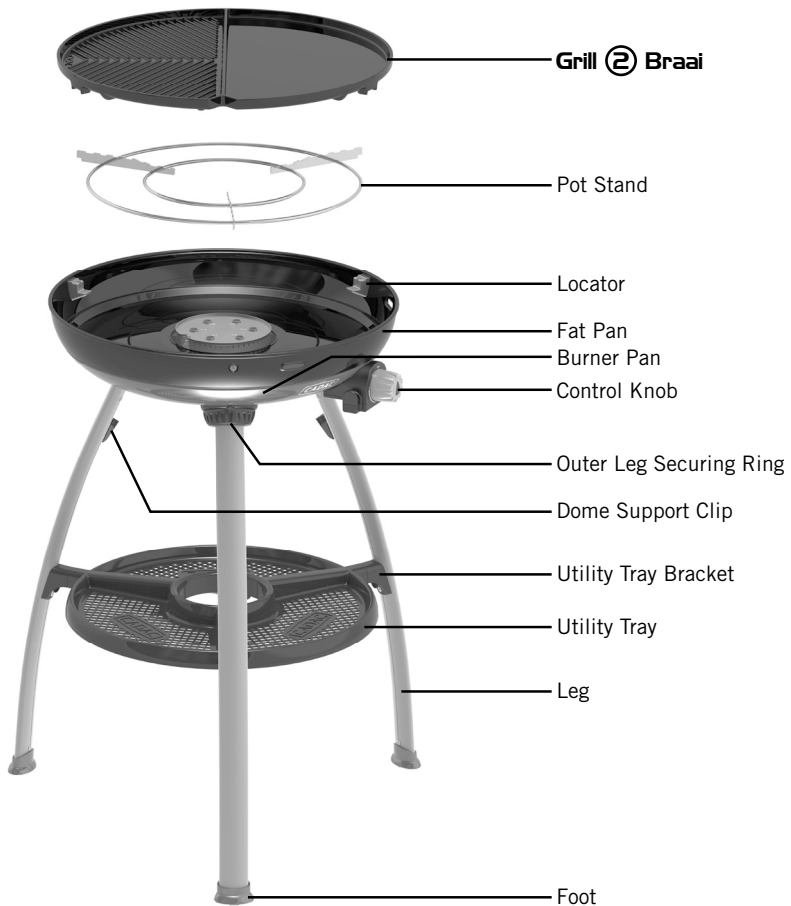

Fig. 9b

## 4. Combos

Carri Chef 2 BBQ / Grill  Braai-Combo 3 (Product Code 8910-52)



Fig. 9c

## 4. Combos

### Carri Chef 2 Gourmet Combo (Product Code 8910-70)



Fig. 9d

## 4. Combos

### Carri Chef 2 BBQ Plancha Combo (Product Code 8910-80)

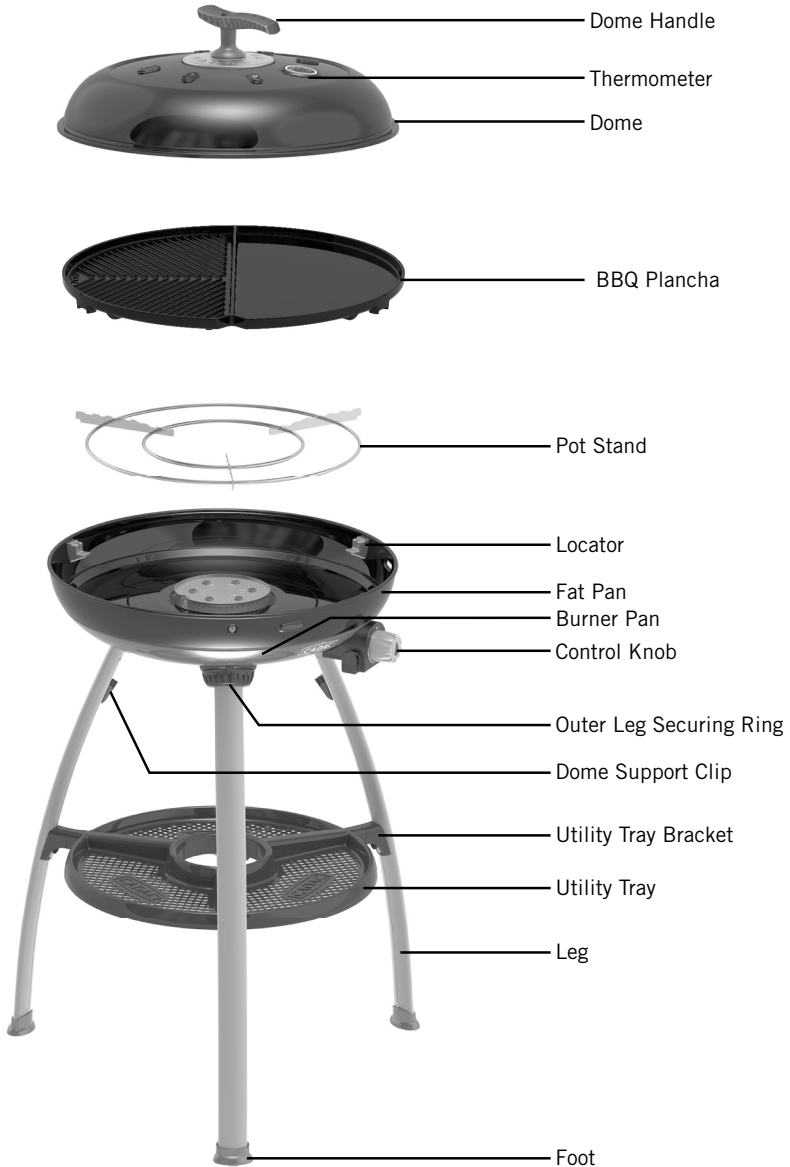

Fig. 9e

## 5. Fitting and Changing the Hose and Gas Cylinder

- **NOTE!** When installing the tailpiece, ensure it is held straight while tightening the tailpiece nut, in order to prevent a possible gas leak. Tighten with a suitable spanner. (Fig. 10)
- I 3B/P (30), I 3B/P (37) and I 3+ (28-30/37) Appliance categories: Fit the valve tailpiece onto the valve by screwing it on in an anti-clockwise direction. Push an approved hose onto the valve tailpiece until it is properly seated. On the other end, attach a suitable low pressure regulator (I3B/P (30) : 30mbar Butane/Propane configurations regulator; I3+(28-30/37): 30mbar Butane regulator or 37mbar Propane regulator); I3B/P(37): 37mbar Butane/Propane configurations regulators). Again making sure that the hose is well seated. The type of hose used shall comply with the relevant EN standard and locate requirement. In South Africa the regulator used must comply with SANS 1537.
- I 3B/P (50) Appliance category: Screw a Hose with the correct threaded fittings on each end, onto the left hand ¼" BSP thread of the Valve. Attach a suitable 50mbar low-pressure regulator on the other end of the hose. The hose assembly used must comply with DIN 4815 part 2 or equivalent.
- The hose length should be no less than 800mm and shall not exceed 1.5m. Check the manufacture date on the hose and replace when necessary or when national regulations require it.
- Do not twist or pinch hose. Ensure the hose does not come into contact with any surfaces that would become hot during use.
- Before fitting the regulator to a gas container, ensure that the seal on the regulator is in position and in good condition. This should be done with every connection and before every use.
- Before fitting your gas cylinder, ensure that the Valves are all in the "OFF" position by turning the Control Knob clockwise to its stop.
- Ensure that the gas container is fitted or changed in a well-ventilated location, preferably outdoors, away from any source of ignition such as naked flames or electric fires and away from other people.
- Making sure that the gas container is kept upright, screw the regulator onto the container until it is fully engaged. Hand-tighten only.
- If there is a leak on your appliance (smell of gas), close the cylinder valve immediately and follow the procedure to detect and stop a leak under Section 3. If you wish to check for leaks on your appliance, do it outside using soapy water only, which is applied to the joints. A formation of bubbles will indicate the gas leak.
- Check that all the connections are securely fitted and re-check with soapy water. If you cannot rectify the gas leak, do not use the appliance. Contact your local CADAC stockist for assistance.
- When changing a gas container, firstly close the container valve (if fitted) and then turn the Control Knob clockwise to its stop position.
- Ensuring that the flame is extinguished, unscrew the regulator. Refit a full container following the same precautions as described above.

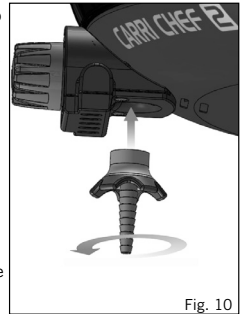

Fig. 10

## 6. Lighting the appliance

- Precautions to observe before lighting.**
- After prolonged storage, inspect the Air Holes in the Valve Cover for insects, which may affect gas flow. Inspect the inlet of the Venturi for insects. After checking, refit all components into the prescribed position.
  - **Use this appliance only on a firm level surface.**
- Using the control knob
- The control knob is fitted with two positive stop positions, one at low, and one at Ignite / High. This limits the adjustment of the flame to between these two points.
- Lighting up using the Piezo Igniter
- To light up the appliance using the piezo igniter, push in and turn the control knob in an anti-clockwise direction until you hear a click. If the gas does not ignite on the first spark, push in, and turn the control knob fully clockwise. Try again, by pushing in and turning the control knob anti-clockwise until you hear a click. If the gas has not ignited in the first two to three seconds you should close the control valve by pushing in the control knob, and turning it fully clockwise. Wait approximately thirty seconds to let any accumulated gas within the burner pan assembly escape. Repeat the above process if necessary until the flame ignites. The flame should normally light up within the first one or two seconds.
- Lighting up using a BBQ lighter
- When starting cold, the appliance may be lit from the top prior to fitting the desired cooking surface onto the fat pan. When lighting up a hot appliance however, it is recommended that this be done by sticking barbecue lighter through one of the Vent Holes underneath the Burner, until it is in line with the burner(DO NOT place the BBQ lighter through the large hole directly underneath the burner). Ignite the BBQ lighter. Whilst the BBQ lighter is lit, push in and turn the control knob anti-clockwise to light the burner.
- General
- Once the appliance is lit, the flame intensity may be adjusted by turning the valve knob anti-clockwise to reduce the flame, or clockwise to increase the flame.
  - The fully closed position is at the furthest clockwise position. To rotate the valve from the fully closed position it is necessary to first depress the knob just enough to move out of the lock mechanism. While holding the knob in, turn it in an anti-clockwise direction. Once the spindle has moved out of the lock position it is no longer necessary to keep the control knob depressed and it can be rotated freely to the desired flame setting.
  - The flame may be observed through the Inspection Hole provided for this purpose on the side of the fat pan.
  - When cooking food with a high fat content, flaring may occur if the selected heat setting is too high. Should this happen, turn the heat down until the flaring ceases.
  - Do not move the appliance when in use as, apart from being an unsafe practice, to move the appliance whilst lit, may cause flaring.
  - After use, first close the valve on the gas container (where applicable). When the flame has extinguished, close the valve on the appliance by pushing in and turning the Control Knob fully clockwise.

## 7. Using the Appliance and its cooking surfaces

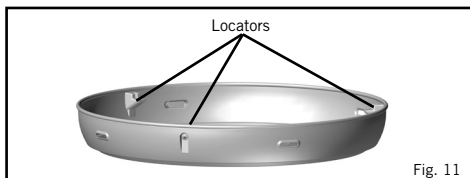

Fig. 11

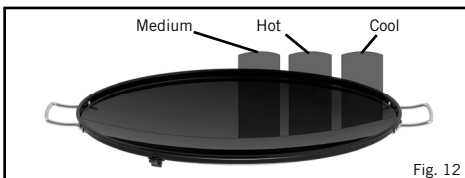

Fig. 12



8910-101

Fig. 13



8910-103

Fig. 14

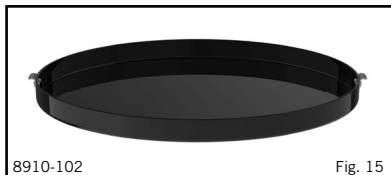

8910-102

Fig. 15

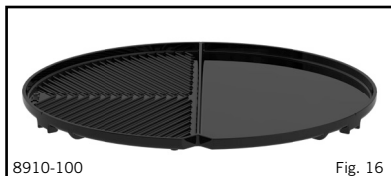

8910-100

Fig. 16



8910-105

Fig. 17



8910-110

Fig. 18

### BBQ Grid (Fig. 13)

- Included with 8910-20, 9810-21, 8910-30, 8910-40, 9810-50, 8910-52 and 8910-70
- The BBQ Grid locates on three die-cast locators in the fat pan (Fig. 11).
- Available as an additional accessory and spare.
- Ceramic non-stick coated cooking surface.
- Do not use metal cooking utensils as this will cause damage to the ceramic non-stick coating.
- Ideal for grilling meat, fish, chicken and vegetables.
- A convenient carry bag is included with this cooking surface.
- **WARNING:** We recommend the use of gloves when handling the BBQ Grid.

### Skottel (Fig. 14)

- Included with 8910-10, 8910-11 and 8910-30.
- The Skottel sits on its own locators in the fat pan.
- Available as an additional accessory and spare.
- Porcelain enamel-coated cooking surface.
- Ideal for wok-style cooking, stir-fries, pasta dishes, and breakfasts.
- A convenient carry bag is included with this cooking surface.
- **WARNING:** We recommend the use of gloves when handling the Skottel.

### Chef Pan (Fig. 15)

- Included with 8910-40
- The Chef Pan locates on three die-cast locators in the fat pan (Fig. 11).
- Available as an additional accessory and spare
- Ceramic non-stick coated cooking surface.
- Do not use metal cooking utensils as this will cause damage to the ceramic non-stick coating.
- **WARNING:** When pre-heating, do not use the Chef Pan on a high flame setting with the dome for more than 15 minutes as this can damage the ceramic non-stick coating and the pan .
- **WARNING:** We recommend the use of gloves when handling the Chef Pan.

### Grill @ Braai (Fig. 16)

- Available as an additional accessory and spare (Included with 8910-50, 9810-51 and 9810-52).
- The Grill @ Braai locates on three die-cast locators in the fat pan (Fig. 11).
- Ceramic non-stick coated cooking surface.
- Do not use metal cooking utensils as this will cause damage to the ceramic non-stick coating.
- The flat half is ideal for cooking fish, breakfasts, and pancakes, whilst the ribbed half is ideal for grilling meat, fish, chicken, and vegetables.
- A convenient carry bag is included with this cooking surface.
- **WARNING:** We recommend the use of gloves when handling the Grill @ Braai.

### Enamel Roast Pan (Fig. 17)

- Available as an additional accessory and spare (not Included).
- Porcelain enamel-coated cooking surface.
- Ideal for preparing roast chicken, lamb, vegetables, etc.
- Porcelain enamel-coated cooking surface.
- **WARNING:** We recommend the use of gloves when handling the Roast Pan.

### Pizza Stone (Fig. 18)

- Available as an additional accessory and spare (not Included).
- 10mm thick baking stone that can withstand temperatures of up to 500°C
- Includes nickel-plated wire holder.
- **WARNING:** We recommend the use of gloves when handling the baking Stone. Please read pizza stone manual carefully before use.

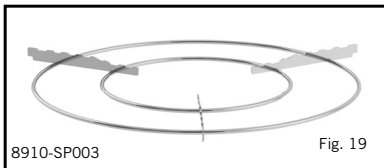

**Pot Stand** (Fig. 19)

- Included with 8910-10, 8910-11, 8910-20, 8910-21, 8910-30, 8910-40, 8910-50, 8910-51, 8910-52, 8910-70 and 8910-80.
- Nickel-plated pot stand, to support most standard size pots.
- **WARNING:** We recommend the use of gloves when handling the Pot Stand.



**Paella Pan 47** (Fig. 19.1)

- Included with 8910-70.
- This 47cm lightweight but thick aluminium ceramic non-stick coated pan is easy to use and clean.
- Stainless steel handles allow for easy handling.
- The underside of the pan is a clear, steel machined finish.
- A convenient carry bag is included.
- **WARNING:** We recommend the use of gloves when handling the Paella Pan.

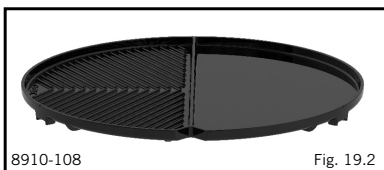

**2-IN-1 BBQ Plancha** (Fig. 19.2)

- Included with 8910-80.
- The BBQ Plancha gives maximum versatility with open grill BBQ on one side and flat grill pan on the other.
- The ceramic coated top is easy to use and clean.
- A convenient carry bag is included.
- **WARNING:** We recommend the use of gloves when handling the BBQ Plancha.

- **IMPORTANT!** To ensure validity of your warranty, use only dedicated **CARRI CHEF**  cooking surfaces
- **NOTE!** Always use the wind shield if you use the appliance in windy conditions

## 8. General Maintenance

- The onus of maintaining this appliance solely rests on the consumer from date of purchase. This appliance does not require scheduled maintenance.

### Replacing a Blocked Jet:

- Your Carri Chef is fitted with a specific size jet to regulate the correct amount of gas.
- Should the hole in the Jet become blocked, this may result in a small flame or no flame at all. Do not attempt to clean the Jet with a pin or other such device as this may damage the orifice, which could make the appliance unsafe.
- **To replace the Jet:** Remove the three screws from the heat shield plate (Fig. 21). Remove the Heat shield plate (Fig. 22), taking care not to damage the piezo electrode. The Jet (B) can now be removed using a suitable spanner (Fig. 23). Do not use pliers on the jet as this may damage the jet, making it unusable or impossible to remove. Screw the new jet into the valve. Do not over-tighten as this may damage the jet.
- Reverse the above procedure to re-assemble the unit.

### Replacing the Hose:

- The fitting of a hose is described in Section 4 - Fitting and replacing the hose and gas cylinder.



Fig. 20

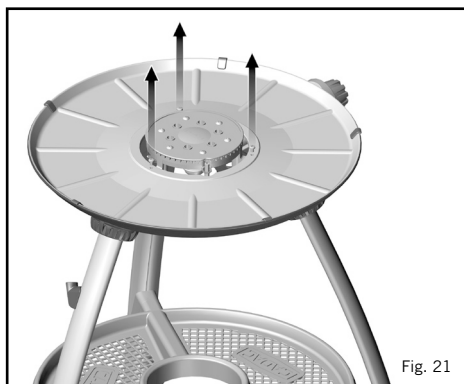

Fig. 21

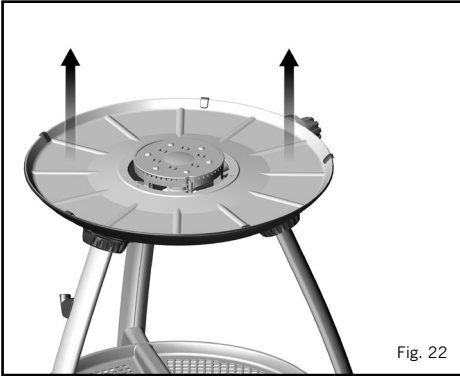

Fig. 22

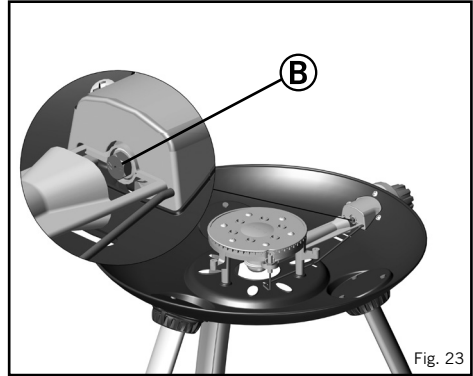

Fig. 23

## 9. Cleaning

- **Note:** For Parts Reference (See Section 7)
- **Skottel BBQ:** After cooking, leave the burner on low with soapy water in the cooking dish to soften cooking residue. When satisfied that excess fat has been removed, wash the Skottel BBQ in warm water using a suitable non-abrasive detergent. Do not use sharp metal objects or abrasive detergents on the vitreous enamel coated surface.
- **BBQ:** Remove the fat from the moat at the bottom of the Fat Pan and clean as described for the Skottel BBQ. Wash the Grid and Deflector Plate in warm water with non-abrasive detergent after wiping off any excess fat left after cooking.
- **BBQ Lid:** Wash the BBQ Lid in warm water using a suitable non-abrasive detergent. Do not use sharp metal objects or abrasive detergents, as this will damage the surface coating.
- **Note:** For stubborn stains, oven cleaner may be used.
- Care of Non-Stick Cooking surfaces:
  - The Non-stick cooking surfaces are coated with a PTFE non-stick coating that has been used with great success on some of the best cookware in the world. Nevertheless, taking care of it can help you to enjoy extra years of healthy, easy, non-stick cooking.
  - Use only low or medium heat settings to help retain the valuable nutrients in the food and maintain the non-stick cooking surface.
  - The non-stick coating can easily be damaged by the use of metal cooking utensils.
  - **NB! It is recommended that only plastic or wooden utensils be used when cooking.**
  - Do not overheat the Non-stick cooking surfaces and always add a little cooking oil to the surface before use.
  - **Always allow the Non-stick surfaces to cool before immersing it in water.**
  - The non-stick coating is perfectly safe in the dishwasher, but the non-stick surface is so easy to clean that a quick hand-wash does the trick. **The use of abrasive detergents is not recommended, as this will permanently damage the non-stick surface.**
  - After cleaning recondition the surface with a light wipe of vegetable oil.
  - After every use, remove the fat from the Fat Pan and clean as described for the BBQ above.

## 10. Storing and Carrying

- Your CADAC Carri Chef is supplied with a variety of Carry Bags that offer portability and allow you to conveniently store all components included with your model within the supplied bags.
- Store your Carri Chef in the following manner:
- Main Bag holds the following parts:
  - Burner Pan
  - Fat Pan (resting on top of the Burner Pan)
  - The Pot Stand
- BBQ Lid fits on the rear of the bag with the support straps that are provided.
- Skottel bag fits the Skottel Dish.
- BBQ Grid bag fits the BBQ Grid
- Non-Stick Chef Pan bag fits the Non-Stick Chef Pan.
- **Grill@Braai** bag fits the **Grill@Braai**.
- Paella Pan 47 bag fits the Paella Pan 47.
- BBQ Plancha bag fits the BBQ Plancha.
- The Leg assemblies fit on the rear of the main bag, with the support straps that are provided.
- Always store your CADAC Carri Chef in the supplied bags, in a dry environment, preferably off the ground. This is especially important for the Burner pan stored in the Main bag so as to prevent the ingress of dirt or insects that may affect the gas flow.
- Always allow the unit to cool down before packing any part into its bag.
- Should the appliance operate abnormally after storage and all checks referred to in Sections 5 & 8 have not isolated any problem, the Venturi may be blocked. A blocked Venturi would be indicated by a weaker yellowish flame or no flame at all in extreme cases. Under these circumstances it will be necessary to remove the Burner as described under Section 8 - General Maintenance, and to check and thoroughly clean out any foreign matter which may have gathered in the Venturi.

## 11. Returning the appliance for repair or service.

- Do not modify the appliance, as this could be dangerous.
- If you cannot rectify a fault by following these instructions, contact your local CADAC distributor for details on how to return the product for attention.
- Your CADAC Carri Chef is guaranteed by CADAC for a period of 2 years against factory fault.

## 12. Spares and Accessories

- Always use genuine CADAC spares as they have been designed to give optimum performance.

