

Instant™

VORTEX™ PRO

10 QUART AIR FRYER OVEN



User manual

- Important safeguards
- Product, parts and accessories
- Get started
- Control panel
- Cooking
- Rotisserie cooking
- Care, cleaning and storage
- Troubleshooting
- Warranty
- Contact

Download the Instant Pot app with
1000+ recipes at instantappliances.com/app.



IMPORTANT SAFEGUARDS



(Yes, we have to)

At Instant Brands™ your safety always comes first. The Instant™ Vortex™ Pro family was designed with your safety in mind, and we mean business. Visit instantappliances.com to learn about this appliance's safety mechanisms.

When using electrical appliances, basic safety precautions should always be followed:

- 01** READ ALL INSTRUCTIONS, SAFEGUARDS, AND WARNINGS BEFORE OPERATING THE APPLIANCE. FAILURE TO FOLLOW THESE SAFEGUARDS AND INSTRUCTIONS MAY RESULT IN INJURY AND/OR PROPERTY DAMAGE.
- 02** The appliance's outer surfaces may become hot during use. DO NOT touch hot surfaces. Wear proper hand protection when handling hot components. Extreme caution must be used when moving the appliance. Let the appliance cool to room temperature before handling or moving.
- 03** **⚠ CAUTION** To protect against the risk of electrical shock, DO NOT immerse power cord, plug, or the appliance in water or other liquid.
- 04** DO NOT rinse the appliance under tap.
- 05** The cooking chamber contains electrical components. To avoid electrical shock, DO NOT put liquid of any kind into the cooking chamber.
- 06** This appliance is NOT to be used by children or by persons with reduced physical, sensory, or mental capabilities. Close supervision is necessary when this appliance is used near children and these individuals. Children should not use or play with this appliance.
- 07** Unplug from the outlet when not in use, as well as before adding or removing parts or accessories, and before cleaning. To unplug, grasp the plug and pull from the outlet. NEVER pull on the power cord.
- 08** Avoid making contact with moving parts.
- 09** Inspect the appliance and power cord regularly. DO NOT operate any appliance with a damaged cord or plug or after the appliance malfunctions, or is dropped or damaged in any manner. For assistance, contact the Customer Care Team at support@instantappliances.com or **1-800-828-7280**.

⚠ WARNING

Read this manual carefully and completely and retain for future reference. Failure to adhere to safety instructions may result in serious injury or damage.

IMPORTANT SAFEGUARDS



- 10 DO NOT use any accessories or attachments not authorized by Instant Brands Inc. The use of attachments not recommended by the manufacturer, may cause a risk of injury, fire or electric shock.
- 11 For household countertop use only. DO NOT use outdoors. Not for commercial use.
- 12 DO NOT place the appliance on any kind of stovetop, or in a heated oven; heat from an external source will damage the appliance.
- 13 DO NOT let power cord contact hot surfaces or open flame, including a stovetop.
- 14 DO NOT use appliance for anything other than intended use.
- 15 Proper maintenance is recommended after each use. Refer to **Care, cleaning and storage**. Let the appliance cool to room temperature before cleaning or storage.
- 16 **⚠ CAUTION** Spilled food can cause serious burns. A short power-supply cord is provided to reduce the hazards resulting from grabbing, entanglement and tripping. Keep appliance and cord away from children. NEVER drape cord over edge of table or counter, NEVER use power outlet below counter, and NEVER use with an extension cord.
- 17 DO NOT attempt to repair, replace, alter, or modify components of the appliance. This may cause electric shock, fire and/or injury, and will void the warranty.
- 18 DO NOT tamper with any of the safety mechanisms.
- 19 DO NOT use the appliance in electrical systems other than 120 V ~ 60 Hz. DO NOT use with power converters or adapters.
- 20 DO NOT overfill the appliance or accessories. Overfilling may cause food to contact the heating element, which may result in fire and/or personal injury.
- 21 DO NOT cover the cooling vents while the appliance is in operation. Doing so will prevent even cooking and may cause damage to the appliance.
- 22 NEVER pour oil into the cooking chamber. Fire and personal injury could result.

⚠ WARNING

Read this manual carefully and completely and retain for future reference. Failure to adhere to safety instructions may result in serious injury or damage.

IMPORTANT SAFEGUARDS



- 23 While cooking, the internal temperature of the appliance reaches several hundred degrees. To avoid personal injury, NEVER place unprotected hands inside the appliance until it has cooled to room temperature.
- 24 When cooking, DO NOT place the appliance against a wall or against other appliances. Leave at least 13 cm / 5" of free space on the back, sides, and above the appliance. DO NOT operate the appliance on or near combustible materials such as tablecloths and curtains. DO NOT place anything on top of the appliance.
- 25 When in operation, hot air is released through the cooling vents. Keep your hands and face at a safe distance from the cooling vents and take extreme caution when removing the accessories from the appliance.
- 26 Should the unit emit black smoke, press **Cancel** and unplug the appliance immediately. Wait for smoking to stop before opening the door, then clean the appliance thoroughly.
- 27 DO NOT leave the appliance unattended while in use.
- 28 NEVER connect this appliance to an external timer switch or separate remote-control system.
- 29 Use extreme caution when removing hot accessories from the cooking chamber or disposing of hot grease.
- 30 Oversized foods and/or metal utensils must not be inserted into the cooking chamber as they may cause risk of fire and/or personal injury.
- 31 DO NOT store any materials, other than the included accessories, in the cooking chamber when not in use.
- 32 DO NOT place any combustible materials in the cooking chamber, such as paper, cardboard, plastic, Styrofoam or wood.
- 33 DO NOT use appliance accessories in any other appliance including microwave ovens, toaster ovens, convection or conventional ovens, ceramic, electric, induction or gas cooktops, or outdoor grills.
- 34 **⚠ CAUTION** Use extreme caution when moving an appliance containing hot oil or other hot liquids.

SAVE THESE INSTRUCTIONS.

⚠ WARNING

Read this manual carefully and completely and retain for future reference.
Failure to adhere to safety instructions may result in serious injury or damage.

IMPORTANT SAFEGUARDS



⚠ WARNING

To avoid injury, read and understand the instructions in this user manual before attempting to use this appliance.

⚠ WARNING

Electrical shock hazard. Use grounded outlet only.

- DO NOT remove ground.
- DO NOT use an adapter.
- DO NOT use an extension cord.

Failure to follow these instructions may result in electric shock and/or serious injury.

⚠ WARNING







THE FAILURE TO FOLLOW ANY OF THE IMPORTANT SAFEGUARDS AND/OR THE INSTRUCTIONS FOR SAFE USE IS A MISUSE OF YOUR APPLIANCE THAT CAN VOID YOUR WARRANTY AND CREATE THE RISK OF SERIOUS INJURY.

Special cord set instructions

As per safety requirements, a short power supply cord is provided to reduce the hazards resulting from grabbing, entanglement and tripping.

This appliance has a 3-prong grounding plug. To reduce the risk of electric shock, plug the power cord into a grounded (earthed) electrical outlet that is easily accessible.

Product specifications

					
Model: Vortex Pro 10	1500 W	120 V ~ 60 Hz	10 Quart	17.53 lb / 7.95 kg	in: 13.78D x 13.23W x 14.37H cm: 35D x 33.6W x 36.5H

Find your model name and serial number

Find both of these on the rating label on the back of the air fryer oven, near the power cord.

⚠ WARNING

Read this manual carefully and completely and retain for future reference. Failure to adhere to safety instructions may result in serious injury or damage.

Table of contents

IMPORTANT SAFEGUARDS	1
Special cord set instructions.....	5
Product specifications	5
Find your model name and serial number	5
Product, parts and accessories	7
Get started	8
Initial set up.....	8
Initial test run	9
Control Panel	10
Settings.....	11
Status messages.....	12
Cooking	13
Air Fry, Roast, Broil and Bake	13
Cooking tips	15
Proof, Dehydrate, Reheat and Toast	16
Rotisserie cooking	18
Rotisserie accessories.....	18
Removing the accessories	22
Care, cleaning and storage	23
The oven door	24
Troubleshooting	25
Warranty	26

Product, parts and accessories

Before using your awesome new air fryer oven, make sure that everything is present and accounted for.

Air fryer oven

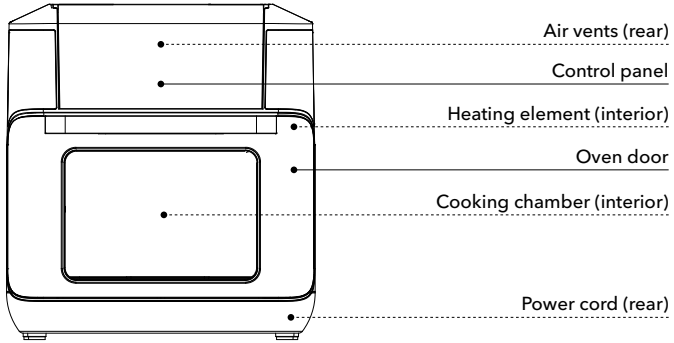

Accessories

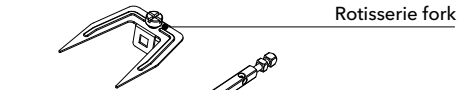
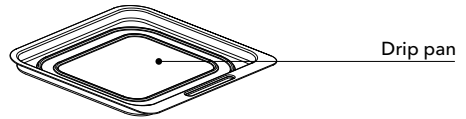
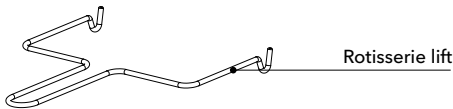
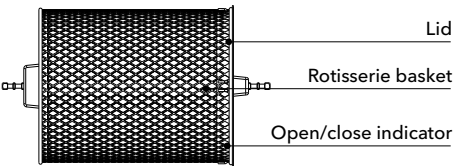
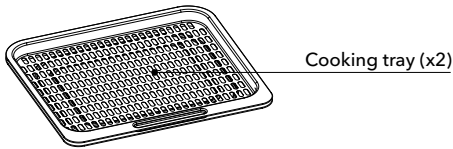



*Illustrations in this document are for reference only and may differ from the actual product.
Always refer to the actual product.*

Get started

Initial set up

 **"No one is born a great cook; one learns by doing." - Julia Child**

- 01** Pull that Vortex Pro out of the box!
- 02** Remove all the packaging material from in and around the oven, and make sure to remove all the accessories from inside the oven chamber.
 Don't remove the safety warning stickers or the rating label from the air fryer.
- 03** You may be tempted to put the Vortex Pro on your stovetop – *but don't do it!* Place it on a stable, level surface, *away* from combustible material and external heat sources. Do not place your Vortex Pro on top of another appliance.
 Make sure to leave *at least* 13 cm / 5" of space above and around all sides of the appliance.
- 04** Follow the **Care, cleaning and storage** instructions to wash your new air fryer before using it.

Is something missing or damaged?

Get in touch with a Customer Care Advisor through our chat widget at instantappliances.com/#chat, by email at support@instantappliances.com or by phone at **1-800-828-7280** and we'll happily make some magic happen for you!

WARNING

Read the Important safeguards before using the appliance. Failure to read and follow those instructions for safe use may result in damage to the appliance, property damage or personal injury.	Do not place the appliance on a stovetop, on another appliance, or in a heated oven. Heat from an external source will damage the appliance.	Do not place anything on top of the appliance, and do not block the air vents.
--	--	--

Get started

Initial test run

Do you *have* to do the test run? No – but getting to know the ins and outs of your Vortex Pro prepares you for success in the kitchen! Take a few minutes to get to know how this baby works.

Stage 1: Setting up for cooking

 This section does not cover Rotisserie set up or cooking. See **Rotisserie cooking: Rotisserie accessories** for details.

- 01** Open the oven door.
Place the drip pan on the bottom of the cooking chamber.

Close the door.
- 02** Connect the power cord to a 120 V power source.
The oven is in standby mode and the display shows **OFF**.
- 03** Touch **Air Fry**.
- 04** Use the **+ / - Time** keys to adjust the cook time to 20 minutes (**00:20**).
- 05** Touch **Start** to begin!
The display shows **On** while the oven preheats, and the cooking status shows **Preheat**.

 The first few times you use your air fryer oven you may notice a plastic smell. This is normal, non-toxic, and goes away quickly.

Stage 2: "Cooking" (...but not really, this is just a test!)

- 01** When the oven reaches the perfect temperature, the display shows **Add Food**.

 Do not add food during the initial test run.
- 02** Open the oven door.

Carefully insert both cooking trays into the preheated cooking chamber.

Close the oven door.

The display alternates to show the cooking time and temperature, and the cooking status shows **Cook**.
- 03** Part way through cooking, the display shows **turn Food**.

Wait 10 seconds for the program to resume automatically, or, open and close the oven door to pause and resume the program manually.
- 04** The display counts down the last minute of cooking in seconds.

When the Smart Program completes, the display shows **End** and the fan blows for a little while to help cool the air fryer.
- 05** Touch **Cancel** to return to standby mode and start cooking for real!

 If you forget this last step, the air fryer will beep to remind you about it after 5, 30, and 60 minutes.

CAUTION

The air fryer oven and air frying accessories will be hot during and after cooking. To avoid the risk of burn injury, DO NOT touch hot surfaces with unprotected hands.

Control panel

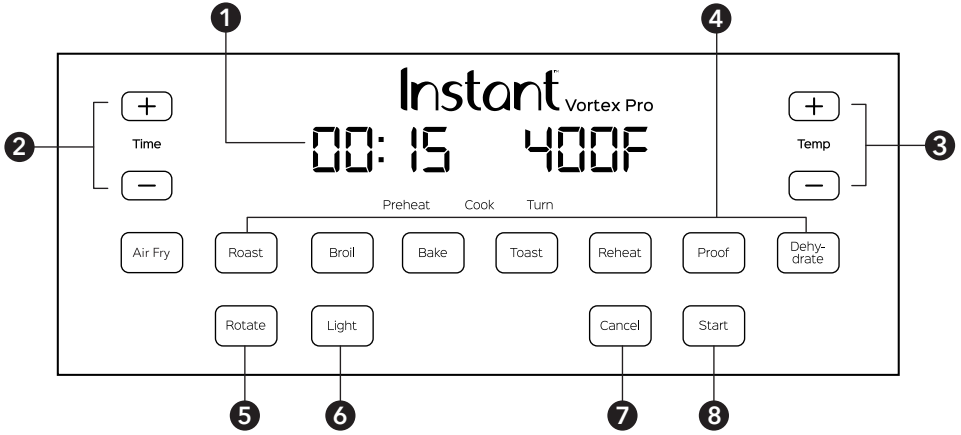



1	Display	Shows the cooking time and the set temperature, as well as display messages and error codes.
2	+ / - Time	Use the + / - Time keys if you want to adjust the cooking time. Touch and hold the key to scroll quickly.
3	+ / - Temp	Use the + / - Temp keys if you want to adjust the cooking temperature. Touch and hold the key to scroll quickly.
4	Smart programs	<ul style="list-style-type: none"> • Air Fry • Roast • Broil • Bake • Toast • Reheat • Proof • Dehydrate
5	Rotate	Touch Rotate during Air Fry or Roast Smart Programs to start and stop the rotisserie rotation.
6	Light	Touch Light to turn the oven light on and off.  The oven light turns off automatically after 2 minutes.
7	Cancel	Touch Cancel to stop a smart program at any time.
8	Start	Touch Start to begin a selected smart program.

*Illustrations in this document are for reference only and may differ from the actual product.
Always refer to the actual product.*

Settings

To do this	Do this!
Wake the air fryer.	Touch any key or open and close the oven door. The display shows OFF to let you know that it's in standby mode and ready for action.
Turn sounds on and off.	In standby mode, touch and hold both – keys (beneath Time and Temp) for 5 seconds.  Error alerts cannot be silenced.
Change temperature scale (°C / °F).	Touch and hold both the + and – Temp keys until the display indicates °C or °F. The temperature is displayed in the unit indicated.
Save a custom cooking time or temperature.	Preset cooking times and temperatures can be changed to create your own custom settings. Select a smart program, then use the + / – Temp and Time keys to make adjustments as you like. Touch Start to save changes to memory.
Reset an individual smart program.	In standby mode, touch and hold the smart program key you want to reset (for example: Air Fry) for 5 seconds. The cooking time and temperature for that Smart Program is restored to the factory default settings.
Reset all smart programs.	In standby mode, touch and hold both + keys (above Temp and Time) for 5 seconds. All Smart Programs are restored to default settings.

Status messages

OFF	The Vortex Pro is in standby mode.
On	A smart program is in the Preheat stage.  Not applicable to Toast, Proof, Reheat and Dehydrate.
Add Food	This message appears to let you know that the air fryer oven has reached the perfect cooking temperature and food can be added (if it hasn't been already).  Not applicable to Toast, Proof, Reheat and Dehydrate.
00:15	The display shows the cooking time and on-screen messages.
400F	The display also shows the set cooking temperature and on-screen messages.
Turn Food	Food is ready to be turned or tossed, as recommended by your recipe.  Only applies to Air Fry and Roast.
End	The Smart Program has finished.

Cooking

Cooking in the Vortex Pro is quick and easy – food goes in, crispy deliciousness comes out!

Check out the **cooking timetables** for guidance, or visit our **recipe site** for fun, easy-to-follow instructions. You can also download the free **Instant Pot app** to search recipes, save favorites and more.

Cooking accessories

The non-stick **cooking trays** are perforated for airflow and should be used for most foods, like wings and cauliflower bites.

The non-stick **drip pan** doubles as a flat cooking tray when you're baking cookies, or cooking fragile food like fish, and filled-foods like jalapeno poppers or cheese-stuffed chicken.

You can place food right on the cooking tray(s) or the drip pan, or, in/on any oven-safe cookware on the cooking tray.

For information on the rotisserie accessories, see **Rotisserie cooking: Rotisserie accessories**.

Air Fry, Roast, Broil and Bake

These programs give your meals all the rich, crispy flavor of deep frying with little to no oil, so you can say, "See ya!" to the greasy mess and extra calories! The presets are a starting point that you can experiment with to get the results you prefer.

Smart program	Default time	Time range	Default temperature	Temperature range	Notes
Air Fry	18 minutes (00:18)	1 minute to 1 hour (00:01 to 01:00)	205°C / 400°F	82 to 205°C 180 to 400°F	For all your favorite deep-fried meals, like fries, cauliflower bites, wings, nuggets and more.
Roast	40 minutes (00:40)	1 minute to 1 hour (00:01 to 01:00)	193°C / 380°F	82 to 205°C 180 to 400°F	Ideal for vegetable dishes, beef, lamb, pork, poultry and more.
Broil	8 minutes (00:08)	1 to 40 minutes (00:01 to 00:40)	205°C / 400°F	Not adjustable	Direct top-down heating, perfect for melting cheese on French onion soup, nachos and more.
Bake	30 mins (00:30)	1 minute to 1 hour 00:01 to 01:00	185°C / 365°F	82 to 205°C 180 to 400°F	Light and fluffy cakes and pastries, scalloped potatoes and more.

Cooking



Stage 1: Setting up for cooking

- 01** Follow steps 01 and 02 in the **Initial test run: Stage 1** to set up the air fryer oven.
- 02** Select a Smart Program by touching: **Air Fry, Roast, Broil** or **Bake**.
- 03** Use the **+ / – Temp** keys to adjust the cooking temperature.
- 04** Use the **+ / – Time** keys to adjust the cook time.
 -  Smart Programs automatically save the adjustments you make to the temperature and time settings when you touch Start.
- 05** Touch **Start** to begin!

The display shows **On** while the oven preheats.

 -  You can adjust the time or temperature any time with the **+ / –** keys (then press **Start** to confirm the change) but changes made after the Smart Program begins are not saved.

Stage 2: Cooking

- 01** When the display shows **Add Food**, open the oven door and carefully place your food items inside.
 -  Except when rotisserie cooking, you can put food in the oven before or after preheating, as your recipe recommends. Cooking will start 10 seconds after the notification appears, whether food has been added or not.
- 02** Close the oven door. The display alternates showing the cooking time and temperature.
- 03** Part way through cooking, the display may show **turn Food**.
 -  This message only appears during the Air Fry and Roast Smart Programs.

Open the oven door if you want to turn or toss your food, or, if you're using both cooking trays, swap their positions in the cooking chamber for more even results.

Close the oven door to resume the cooking program.

 -  If your food doesn't need to be flipped, wait 10 seconds for the program to resume automatically.
- 04** When the display shows **End**, carefully open the door, and, using proper hand protection, remove your food from the cooking chamber.

CAUTION

The air fryer oven and air frying accessories will be hot during and after cooking. Do not touch hot surfaces with unprotected hands. Allow all items to cool to room temperature, then clean them according to **Care, cleaning and storage** instructions.

Always use proper hand protection and exercise extreme caution when adding or removing food from the hot cooking chamber.

Cooking

Cooking tips

Give all your favorite fresh and frozen oven-baked and deep-fried snacks a fighting chance!

- Preheating is an important step! Wait for the **Add Food** message to appear before adding food to the cooking chamber.
- When baking cake, pie, quiche, and other treats, use an oven-safe baking dish covered with foil (or an oven-safe lid) to prevent the top from overcooking.
- When cooking pizza, put *both* cooking trays in the oven, and place the pizza on the bottom cooking tray. This keeps the top from overcooking!
- For coated food, like onion rings or deep-fried pickles, use an egg wash with breadcrumbs rather than liquid-based batters to make sure that batter sticks to the food.
- Spray food items with cooking oil *before* adding seasoning to get the seasoning to stick well.
- For super crispy fries, soak your fresh-cut potato sticks in ice water for 15 minutes, then pat them dry and spray them lightly with oil before cooking.
- Patting dry moist food items before cooking prevents excess steam and splatter and gives you crispier results.
- Air frying can cause oil and fat to drip, so always use the drip pan. To prevent excess smoke, watch the oil levels and carefully remove and drain the drip pan as needed.

Check out the **cooking timetables**, download the **Instant Pot app**, or, visit our **recipe site** for fun, easy-to-follow recipes.

⚠ CAUTION

To avoid the risk of fire and/or property damage, do not spray oil into the cooking chamber.

⚠ CAUTION

When cooking meat, always use a meat thermometer to ensure the internal temperature reaches a safe minimum temperature. Refer to the **USDA's Safe Minimum Internal Temperature Chart** or Health **Canada's Cooking Temperatures Chart** for more information.

Cooking

Proof, Dehydrate and Reheat and Toast

Smart program	Default time	Time range	Default temperature	Temperature range	Notes
Dehydrate	7 hours (07:00)	1 to 72 hours (01:00 to 72:00)	49°C / 120°F	35 to 79°C 95 to 175°F	Perfect for homemade fruit leather, jerky, dried vegetables and more.
Reheat	10 minutes (00:10)	1 to 60 minutes (00:01 to 01:00)	138°C / 280°F	49 to 182°C 120 to 360°F	Reheat leftovers without overcooking or drying out.
Proof	30 minutes (00:30)	30 to 40 minutes (00:30 to 00:40)	32°C / 90°F	32 to 49°C 90 to 120°F	For scrumptious loaves and rolls, allow your dough to rest and rise and let the yeast do its job!

01 Follow steps 01 and 02 in the **Initial test run: Stage 1** to set up the air fryer oven.

02 Open the oven door and place your food items inside.
Close the door.

03 Select a Smart Program by touching: **Proof, Dehydrate** or **Reheat**.

04 Use the **+ / - Temp** keys to adjust the temperature.

 If the ambient temperature of your home is higher than the set temperature for Proof, the air fryer oven will not operate effectively.

05 Use the **+ / - Time** keys to adjust the time.

06 Touch **Start** to begin!
The display starts to count down right away.

07 When the display shows **End**, carefully remove your food from the air fryer.

⚠ CAUTION

The air fryer oven and air frying accessories will be hot during and after cooking. Do not touch hot surfaces with unprotected hands. Allow all items to cool to room temperature, then clean them according to **Care, cleaning and storage** instructions.

To avoid burn injury, always use proper hand protection and exercise extreme caution when adding or removing food from the hot cooking chamber.

Cooking

Toast

Toasting darkness level	Default time	Notes
L1 (Level 1)	2 minutes and 50 seconds (02:50)	The toasting level is also affected by how close you place the cooking tray to the element. The higher, the hotter!
L2 (Level 2)	3 minutes and 10 seconds (03:10)	
L3 (Level 3)	3 minutes and 30 seconds (03:30)	

- 01 Follow steps 01 and 02 in the **Initial test run: Stage 1** to set up the air fryer oven.
- 02 Open the oven door and place your food items inside.
Close the door.
- 03 Touch **Toast**.
- 04 The Temp keys are disabled, so use the **+ / - Time** keys to select a toasting level: **L1**, **L2** or **L3**.
 The time changes automatically with the toasting level.
- 05 Touch **Start** to begin!
The display starts to count down right away.

 **Instant Tip:** Flip your toast around the halfway point to make sure it's toasted evenly on both sides.

- 06 When the display shows **End**, carefully remove your food from the air fryer.

⚠ CAUTION

The air fryer oven and air frying accessories will be hot during and after cooking. Do not touch hot surfaces with unprotected hands. Allow all items to cool to room temperature, then clean them according to **Care, cleaning and storage** instructions.

Always use proper hand protection and exercise extreme caution when adding or removing food from the hot cooking chamber.

Rotisserie cooking

The Instant Vortex Pro is equipped with EvenCrisp™ technology for simple rotisserie-style cooking with delicious results.

Always insert rotisserie accessories and food items into the cooking chamber before preheating the air fryer oven.

Read the instructions below and watch this [short video](#) to make sure the rotisserie accessories are being installed correctly. Failure to follow these steps could result in irreparable damage to the rotisserie catch.

Rotisserie accessories

The **rotisserie basket** is perforated to allow maximum airflow for the perfect crisp all over.

- 01** Place food items in the rotisserie basket. Do not overfill the rotisserie basket.

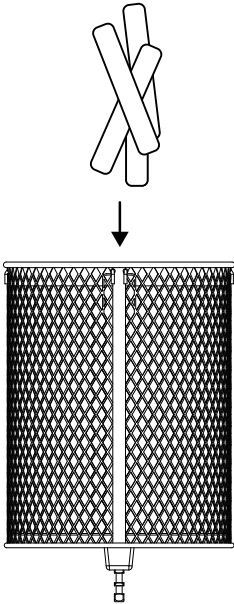

- 02** Align the tab on the rotisserie basket with the notch in the lid, then place the lid on the basket.

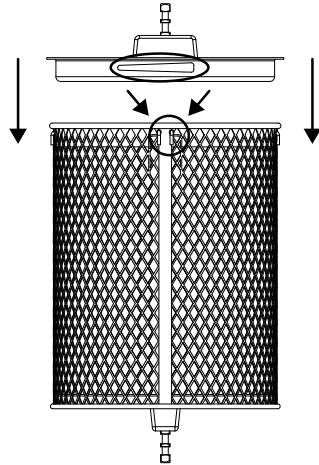

- 03** Turn the lid clockwise to secure it.

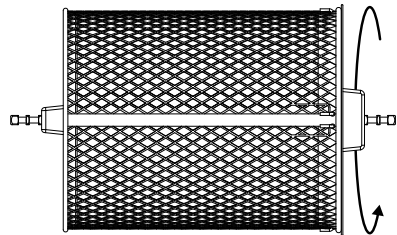

Optionally, spray the basket with non-stick cooking spray before adding food to help prevent sticking.

Rotisserie cooking

The **rotisserie spit and forks** are perfect for roasting whole chicken, tenderloin and much more.

01 Unscrew the 2 setting screws.

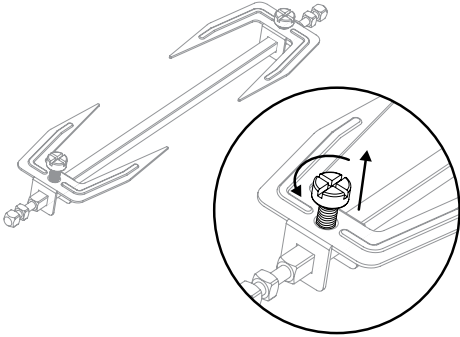

02 Remove the forks from the spit.

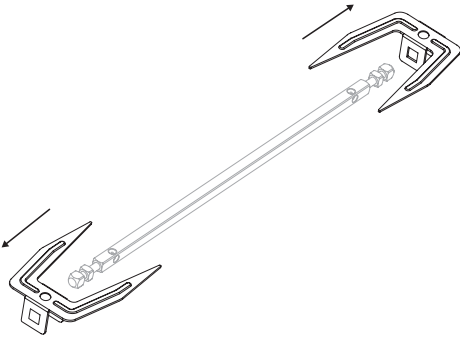

03 Push your food item onto the spit.

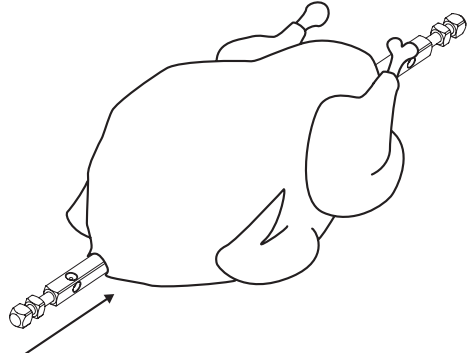

04 Slide the forks onto both ends of the spit, making sure the prongs are inserted into the food item securely on both sides.

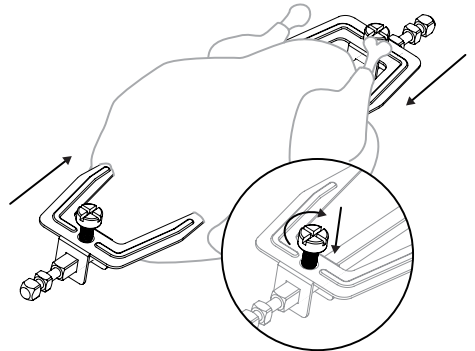

05 When you're happy with the positioning, tighten the setting screws to hold the forks in place.

Rotisserie cooking

Stage 1: Setting up the rotisserie accessories

Follow the steps in **Rotisserie cooking: Rotisserie accessories** to prepare your food.

- 01 Open the oven door and slide the rotisserie basket or rotisserie spit onto the guides in the cooking chamber.

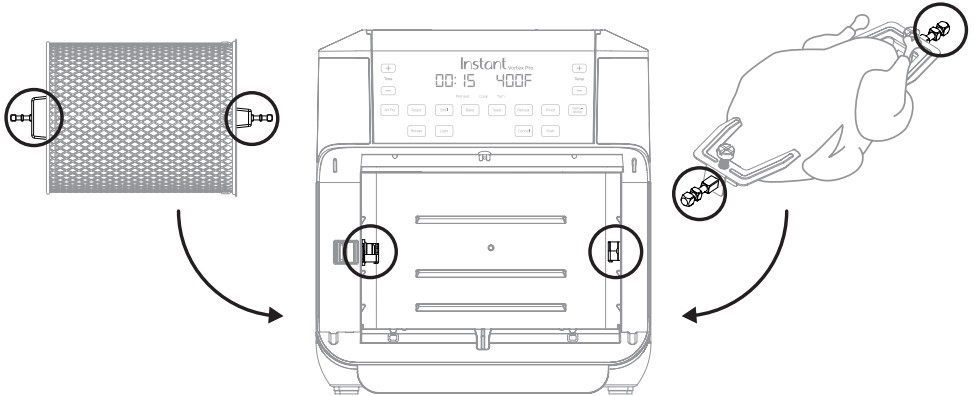

- 02 Move the red rotisserie catch lever to the right and hold it in position. Notice that the rotisserie catch inside the cooking chamber withdraws slightly when you move the lever.

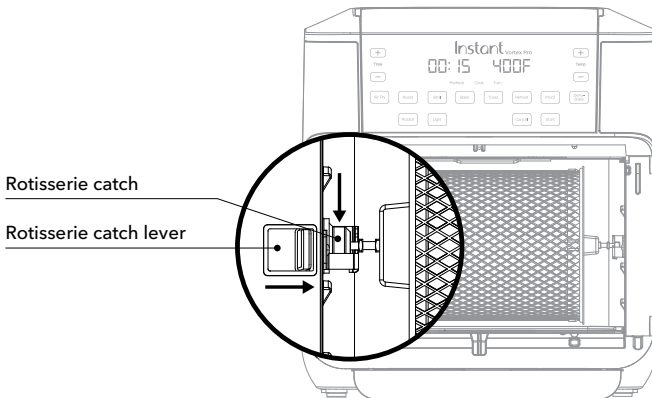

⚠ CAUTION

Read these instructions carefully and/or watch the **tutorial video** to ensure you are using the rotisserie properly. Failure to follow these steps could result in damage to the rotisserie catch.

Rotisserie cooking

- 03** Align the left side of the accessory with the hole in the rotisserie catch, and set the right end of the accessory in the notch on the right.

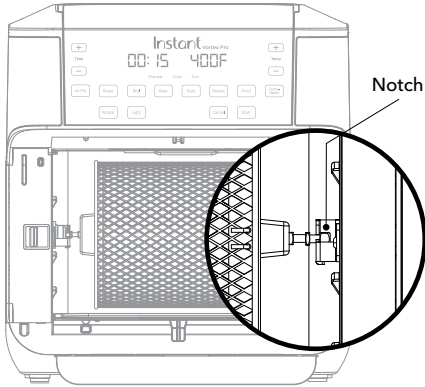

- 04** Release the rotisserie catch lever.

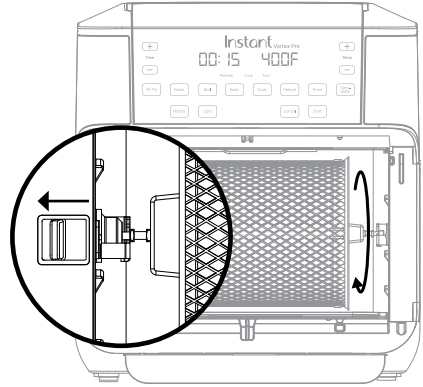

- 05** Rotate the accessory in place to make that it's being held securely. The rotisserie catch inside should move with the accessory – if it does not move, keep rotating the accessory until the rotisserie catch "catches" it completely.
- 06** Close the oven door.

Stage 2: Setting up for cooking

- 01** Connect the power cord to a 120 V power source.
The oven is in standby mode and the display shows **OFF**.
- 02** Select a Smart Program by touching: **Air Fry** or **Roast**.
- 03** Use the **+ / - Temp** keys to adjust the cooking temperature.
- 04** Use the **+ / - Time** keys to adjust the cook time.
- 05** Touch **Start** to begin.
The display shows **On**.
- 06** Touch **Rotate** to start rotisserie cooking!
- 07** When the display shows **End**, carefully remove the rotisserie accessory as described in **Rotisserie cooking: Removing the accessories** on the next page.

Rotisserie cooking

Removing the accessories

The rotisserie basket and rotisserie spit are installed and removed the same way, but backwards!

- 01** Open the oven door.
- 02** Position the hooks on the rotisserie lift beneath the left and right arms of the accessory.

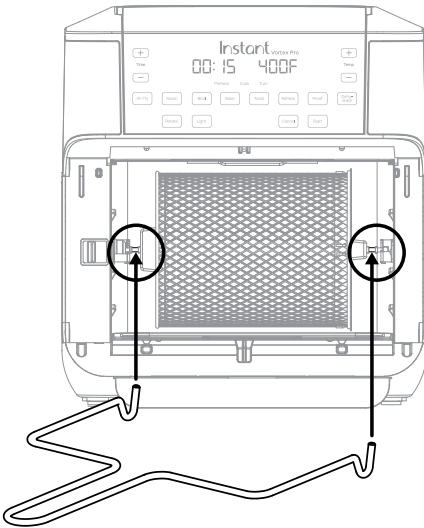

⚠ CAUTION

The air fryer oven and rotisserie accessories will be hot during and after cooking. Always use the rotisserie lift to remove rotisserie accessories and exercise extreme caution when removing food from the hot cooking chamber. Always use proper hand protection when handling and/or disassembling hot rotisserie accessories.

- 03** Move the rotisserie catch lever to the right and hold it in position to release the accessory.

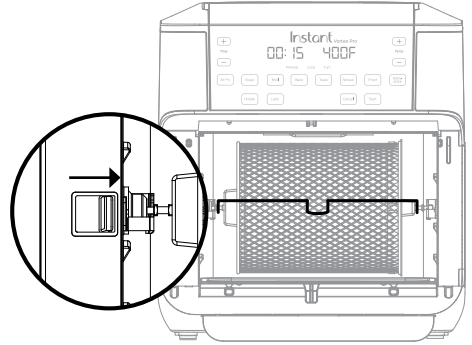

- 04** Pull the accessory towards you, then release the rotisserie catch lever.
- 05** Carefully remove the accessory from the cooking chamber and place it on a secure, heat-resistant surface.

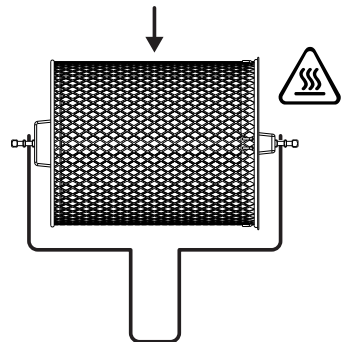

-  Make sure to place it somewhere it won't roll away on you!

Care, cleaning and storage

Clean your Instant Vortex Pro and accessories after each use.

Always unplug the air fryer oven and let it cool to room temperature before cleaning. Never use harsh chemical detergents, scouring pads, or powders on any of the parts or components.

Let all surfaces dry thoroughly before use, and before storage.

Part or accessory	Cleaning method and notes
Drip pan	Dishwasher safe. <ul style="list-style-type: none"> Remove for cleaning. To prevent smoking, make sure grease and food debris is fully removed. The drip pan has a non-stick coating. Avoid using metal utensils when cleaning.
Cooking trays	Dishwasher safe. <ul style="list-style-type: none"> The cooking trays have a non-stick coating. Avoid using metal utensils when cleaning.
Rotisserie basket	Dishwasher safe. <ul style="list-style-type: none"> For best results, use a bristled brush rather than a sponge or cloth.
Rotisserie spit, forks and screws	Dishwasher safe. <ul style="list-style-type: none"> Disassemble before cleaning. If machine washing, place small parts in washable mesh bag.
Rotisserie lift	Dishwasher safe. <ul style="list-style-type: none"> Clean as needed.
Removable door	Clean with a damp cloth and mild dish soap. <ul style="list-style-type: none"> Remove the door for cleaning. See Care, cleaning and storage: The oven door (on the next page) for details. Allow the door to air dry completely before reinstalling, otherwise the glass may experience clouding.
Cooking chamber	Clean with a damp cloth and mild dish soap. <ul style="list-style-type: none"> Always check the heating coil and cooking chamber walls for oil spatter and food debris, and clean as needed. Ensure the heating coil is dry before turning on the air fryer oven. To remove baked-on grease and food residue from the cooking chamber, spray with a mixture of baking soda and vinegar and wipe clean with damp cloth. For stubborn stains, allow the mixture to sit on the affected area for several minutes before scrubbing clean.
Exterior	Clean with a damp cloth and mild dish soap. <ul style="list-style-type: none"> After cleaning, wipe down with a dry cloth to prevent streaking.
Power cord	Clean with a damp cloth and mild dish soap. <ul style="list-style-type: none"> Clean as needed.

Some discoloration may occur after machine washing, but this will not affect the cooker's safety or performance.

WARNING

To avoid risk of electrical shock and personal injury:

- Do not immerse the appliance in water.
- Do not rinse the appliance under a tap.
- Do not wet prongs of the power cord.

Without proper cleaning, food and grease splatter may build up around the heating element, causing the risk of smoke, fire, and personal injury.

If you see or smell smoke, touch **Cancel**, unplug the appliance, and allow it to cool. Follow instructions above to clean the appliance and accessories.

Care, cleaning and storage

The oven door

The oven door is installed and removed the same way, but backwards!

Remove the oven door

- 01** Place one hand on top of the air fryer oven to hold it firmly in place.
- 02** Open the oven door to a 45° angle from the oven.
- 03** Pull the oven door up from the right side until it pops out of its track.

Reinstall the oven door

- 01** Hold the oven door at a 45° angle from the oven.
- 02** Align the teeth at the bottom of the oven door with the grooves in the air fryer oven.
- 03** Press down on the right side of the oven door until it pops into place, then press the left side down.

Troubleshooting

Register your Instant Vortex Pro today!

If your problem persists or if you have questions, get in touch with a Customer Care Advisor through our chat widget at instantappliances.com/chat#, by email at support@instantappliances.com or by phone at **1-800-828-7280**.

Problem	Possible reason	Solution
Black smoke is coming from the air fryer.	⚠ CAUTION Stop cooking immediately. Cancel the Smart Program then unplug the air fryer and allow it to cool to room temperature.	
	Using an oil with a low smoke point.	Choose a neutral oil with a high smoke point, such as Avocado, Canola, Soybean, Safflower, or Rice Bran oil.
	Food residue on the heating coil, in the cooking chamber or on the accessories.	Remove all accessories from the cooking chamber and clean the area as well as all accessories thoroughly.
	Faulty circuit or heating element.	Contact Customer Care . <i>Note: Do not attempt to repair the appliance.</i>
White smoke is coming from the air fryer.	Cooking foods with a high fat content, such as bacon, sausage, and hamburger.	Avoid air frying foods with a high fat content.
	Water is vaporizing, producing thick steam.	Pat dry moist food ingredients before air frying. Do not add water or other liquid to the cooking chamber when air frying.
	Seasoning on food has blown into the element.	Be mindful when seasoning food. Spray vegetables and meats with oil before seasoning to help the seasoning stick.
The air fryer is plugged in but will not turn on.	The appliance is not properly plugged in.	Make sure the power cord is plugged into the outlet firmly.
	Outlet is not powered.	Plug another appliance into the same outlet to test the circuit.
	The oven door is open.	Make sure the door is fully closed.
All lights flash and a code appears on the display.	E1 Temperature sensor issue.	Contact Customer Care .
	E2 Temperature sensor short circuit.	Contact Customer Care .

Any other servicing must be performed by an authorized representative.

Warranty

Limited Warranty

This Limited Warranty is effective for one year from the date of original consumer purchase. Proof of original purchase date and, if requested by an authorized representative of Instant Brands Inc. ("Instant Brands"), return of your appliance, is required to obtain service under this Limited Warranty. Provided that this appliance is operated and maintained in accordance with written instructions attached to or furnished with the appliance, Instant Brands will, in its sole and exclusive discretion, either: (i) repair defects in materials or workmanship; or (ii) replace the appliance. In the event that your appliance is replaced, the Limited Warranty on the replacement appliance will expire 12 months from the date of original consumer purchase.

This Limited Warranty extends only to the original purchaser and use of the appliance in the United States of America and Canada. This warranty does not cover units that are used outside of the United States of America and Canada.

Any modification or attempted modification to your appliance may interfere with the safe operation of the appliance and will void this Limited Warranty. This Limited Warranty does not apply in respect of any appliance or any part thereof that has been altered or modified unless such alterations or modifications were expressly authorized by an Instant Brands representative.

Limitation and Exclusions

The liability of Instant Brands, if any, for any allegedly defective appliance or part shall in no circumstances exceed the purchase price of a comparable replacement appliance.

This Limited Warranty does not cover:

1. Damage resulting from accident, alteration, misuse, abuse, neglect, unreasonable use, use contrary to the operating instructions, normal wear and tear, commercial use, improper assembly, disassembly, failure to provide reasonable and necessary maintenance, fire, flood, acts of God or repair by anyone unless directed by an Instant Brands Representative;
2. Repairs where your appliance is used for other than normal, personal use or when it is used in a manner that is contrary to published user or operator instructions; or
3. Use of unauthorized parts and accessories, or repairs to parts and systems resulting from unauthorized repairs or modifications made to this appliance.

The cost of repair or replacement under these excluded circumstances shall be paid by you.

Warranty

Disclaimer of Implied Warranties

EXCEPT AS EXPRESSLY PROVIDED HEREIN AND TO THE EXTENT PERMITTED BY LAW, INSTANT BRANDS MAKES NO WARRANTIES, CONDITIONS OR REPRESENTATIONS, EXPRESS OR IMPLIED, BY STATUTE, USAGE, CUSTOM OF TRADE OR OTHERWISE WITH RESPECT TO THE APPLIANCES OR PARTS COVERED BY THIS WARRANTY, INCLUDING BUT NOT LIMITED TO, WARRANTIES, CONDITIONS, OR REPRESENTATIONS OF WORKMANSHIP, MERCHANTABILITY, MERCHANTABLE QUALITY, FITNESS FOR A PARTICULAR PURPOSE OR DURABILITY.

Some states or provinces do not allow for the exclusion of implied warranties of merchantability or fitness, so this limitation may not apply to you. In these states and provinces, you have only the implied warranties that are expressly required to be provided in accordance with applicable law.

Limitation of Remedies; Exclusion of Incidental and Consequential Damage

YOUR SOLE AND EXCLUSIVE REMEDY UNDER THIS LIMITED WARRANTY SHALL BE APPLIANCE REPAIR OR REPLACEMENT AS PROVIDED HEREIN. INSTANT BRANDS SHALL NOT BE LIABLE FOR INDIRECT, INCIDENTAL OR CONSEQUENTIAL DAMAGES ARISING OUT OF OR IN CONNECTION WITH THE USE OR PERFORMANCE OF THE APPLIANCE OR DAMAGES WITH RESPECT TO ANY ECONOMIC LOSS, PERSONAL INJURY, LOSS OF PROPERTY, LOSS OF REVENUES OR PROFITS, LOSS OF ENJOYMENT OR USE, COSTS OF REMOVAL, INSTALLATION OR OTHER INDIRECT, INCIDENTAL OR CONSEQUENTIAL DAMAGES OF ANY NATURE OR KIND.

Warranty Registration

Please visit www.instantappliances.com/support/register to register your new Instant Brands™ appliance and validate your warranty within thirty (30) days of purchase. You will be asked to provide the store name, date of purchase, model number (found on the back of your appliance) and serial number (found on the bottom of your appliance) along with your name and email address. The registration will enable us to keep you up to date with product developments, recipes and contact you in the unlikely event of a product safety notification. By registering, you acknowledge that you have read and understand the instructions for use, and warnings set forth in the accompanying instructions.

Warranty Service

To obtain service under this warranty, please contact our Customer Service Department by phone at 1-800-828-7280 or by email to support@instantappliances.com. You can also create a support ticket online at www.instantappliances.com/support. If we are unable to resolve the problem, you may be asked to send your appliance to the Service Department for quality inspection. Instant Brands is not responsible for shipping costs related to warranty service, save and except for shipping costs associated with the return of your appliance from Canada or within the 48 contiguous states and the District of Columbia of the United States of America, as provided herein. When returning your appliance, please include your name, mailing address, email address, phone number, and proof of the original purchase date as well as a description of the problem you are encountering with the appliance.



Instant Brands Inc.

11–300 Earl Grey Dr., Suite 383
Ottawa, Ontario
K2T 1C1
Canada

Register your product today

instantappliances.com/support/register



Contact us

1-800-828-7280
support@instantappliances.com
instantappliances.com/#chat

instantappliances.com
store.instantappliances.com