

GoWISEUSA®

AIR FRYER OVEN DELUXE

USER MANUAL

Model No.: GW44800-O, GW44801, GW44802-O



Please read through this manual carefully before use

 **IMPORTANT SAFEGUARDS AND TIPS**

WWW.GOWISEUSA.COM

THANK YOU FOR YOUR PURCHASE!

Join

the GoWISE Community on Facebook, Instagram, Twitter, and Pinterest for updates, tips, and great deals!



Explore

recipes on our recipe App or www.gowiseproducts.com/blogs/recipes



Contact Our Customer Care Team

855-233-9199

support@gowiseusa.com

Live Chat at gowiseusa.com

M-F 8:30am - 4:00pm MST



Register Your Product

www.gowiseproducts.com/apps/product-registration

(The serial number is normally underneath the product. Please check there first.)



Specifications

Voltage: 120V, 60Hz

Watts: 1600W

Capacity: 12.7 Qt

Temp. Range: 120°F-430°F



TABLE OF CONTENTS

Register Your Product.....	2
Specifications.....	2
Important Safeguards.....	4
Important.....	7
Overheating Protection.....	7
Electric Power.....	7
Automatic Shut-Off.....	7
Electromagnetic Fields.....	7
Parts and Accessories.....	8
Control Display.....	10
Set Up and Using Air Fryer Oven.....	11
Before First Use.....	11
Using Your Accessories.....	12
Cooking Preset Chart.....	16
Internal Temperature Chart.....	17
Trussing a Whole Chicken.....	18
Rotisserie Roast a Whole Chicken.....	20
Troubleshooting & Error Codes.....	21
Warranty.....	22

IMPORTANT SAFEGUARDS

HOUSEHOLD USE ONLY • READ ALL INSTRUCTIONS BEFORE USE

- 1. NEVER IMMERSE** the main unit housing in water, as it contains electrical components and heating elements. Do not rinse under the tap.
- 2. TO AVOID ELECTRIC SHOCK, DO NOT** put liquid of any kind into the main unit housing containing the electrical components.
- 3. DO NOT PLACE** the unit on stove top surfaces.
- This appliance has a polarized plug (one prong is wider than the other). This plug is intended to fit into a polarized outlet only one way. **TO AVOID ELECTRIC SHOCK, DO NOT** force the plug into the outlet if it does not fit. If the plug does not fit fully into the outlet, reverse the plug. If it still does not fit, contact a qualified electrician. **DO NOT ATTEMPT** to modify the plug in any way.
- Always make sure that the plug is inserted into the wall socket properly and without any other appliances on the same outlet.
- To prevent food being in contact with the heating element, **DO NOT OVERFILL** any of the cooking trays.
- DO NOT COVER OR BLOCK** the air intake vent or air outlet vent while the **GoWISE USA Air Fryer Oven** is in operation. Doing so prevents even cooking and may damage the unit or cause it to overheat.
- 8. NEVER POUR** oil into the square accessory basket. This could result in fire or personal injury.
- While cooking, the internal temperature of the unit reaches several hundred degrees Fahrenheit. **TO AVOID PERSONAL INJURY**, never place hands inside the unit unless it has thoroughly cooled.
- This appliance is **NOT INTENDED FOR USE** by persons with reduced physical, sensory, or mental capabilities or persons with a lack of experience and knowledge unless they are **UNDER THE SUPERVISION** of a responsible person or have been given proper instruction to use the appliance. This appliance is **NOT INTENDED FOR USE** by children.
- When cooking, **DO NOT PLACE** the appliance against a wall or other appliances. Leave at least five inches of free space along the back, sides, and above the appliance. Do not place anything on top of the appliance.
- DO NOT USE** this unit if the plug, the power cord, or the appliance itself is damaged in any way.
- If the power cord is damaged, **YOU MUST HAVE IT REPLACED**

IMPORTANT SAFEGUARDS

HOUSEHOLD USE ONLY • READ ALL INSTRUCTIONS BEFORE USE

by the manufacturer, its service agent, or similarly qualified person to avoid hazard.

14. Keep the appliance and its power cord **OUT OF THE REACH** of children when it is in operation or during the cooling process.
15. **KEEP THE POWER CORD AWAY** from hot surfaces. **DO NOT PLUG** in the power cord or operate the unit controls with wet hands.
16. **NEVER CONNECT** this appliance to an external timer switch or separate remote control system.
17. **NEVER USE** this appliance with an extension cord of any kind.
18. **DO NOT OPERATE** the appliance on or near flammable materials, such as tablecloths and curtains.
19. **DO NOT USE** the **GoWISE USA Air Fryer Oven** for any purpose other than described in this manual.
20. **NEVER OPERATE** the appliance unattended.
21. **KEEP YOUR HANDS AND FACE** at a safe distance from the air outlet vent, as hot air is released through it while in operation. Also, avoid the vent while removing the square accessory basket from the appliance. The unit's outer surfaces may become hot during use. **USE OVEN MITTS** or use the rotisserie tong when handling hot components. Always use oven mitts when handling hot objects and surfaces.
22. Should the unit emit black smoke, **UNPLUG IMMEDIATELY** and wait for smoking to stop before removing oven contents.
23. When the time has run out during a cooking cycle, cooking will stop, but the fan **WILL CONTINUE RUNNING** for 20 seconds to cool down the unit.
24. **ALWAYS** operate the appliance on a horizontal surface that is level, stable, and noncombustible.
25. If the **GoWISE USA Air Fryer Oven** is used improperly, for professional or semi-professional purposes, or if it is not used according to the instructions in this user manual, the warranty becomes invalid, and the manufacturer will not be held liable for damages.
26. **ALWAYS** unplug the appliance after use.
27. Let the appliance cool down for approximately 30 minutes before handling, cleaning, or storing.
28. **MAKE SURE** the ingredients prepared in this unit come out cooked to golden-yellow color rather than dark brown. Remove burnt remnants.

IMPORTANT SAFEGUARDS

HOUSEHOLD USE ONLY • READ ALL INSTRUCTIONS BEFORE USE

- 29.** This appliance is intended for normal household use only. It is not intended for use in commercial or retail environments.
- 30.** Please note that this unit is constantly emitting heat through the air vents, the unit must be placed on a heat-resistant surface. It is the end user's responsibility to verify the heat capacity of their countertops. We recommend using a silicone pad or spare, non-artificial tile to protect your countertops from heat damage. **The care and use of countertops is the responsibility of the end user.**

MAKE SURE THE UNIT RESTS ON A FLAT LEVEL SURFACE 5 INCHES AWAY FROM ANY OTHER WALL OR APPLIANCE AND WELL AWAY FROM ANY CURTAINS, FABRICS, OR CLOTHS.

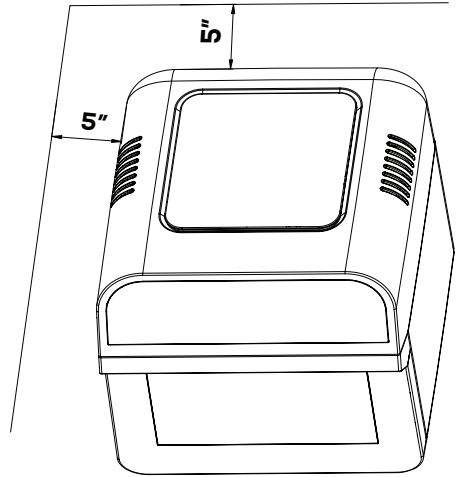

**SAVE THESE
INSTRUCTIONS**

IMPORTANT SAFEGUARDS

Important

- Before initial use and after subsequent use, hand wash all included accessories. Wipe the outside and inside of the unit with a warm moist cloth and mild detergent. Preheat the unit for a few minutes to burn off any residue.
- **NOTE:** The oven may smoke the first time it is used. It is not defective, and the smoke will burn off within a few minutes.

Overheating Protection

Should the inner temperature control system fail, the overheating protection system will be activated, and the unit will not function. Should this happen, unplug the power cord. Allow time for the unit to cool completely before restarting or storing.

Electric Power

If the electrical circuit is overloaded with other appliances, your unit may not operate properly. It should be operated on a dedicated electrical circuit.

Automatic Shut-Off

The appliance has a built-in shut-off device which will automatically shut down the unit when the timer LED reaches zero. You can manually turn off the appliance by pressing the power button. The fan will continue running for about 20 seconds to cool down the unit.

Electromagnetic Fields

This appliance complies with all standards regarding electromagnetic fields. According to the instructions in this manual, the appliance is safe to use based on scientific evidence available today if handled properly.

PARTS AND ACCESSORIES

PARTS

1. Top Air Intake Vent
2. Control Display
3. Side Air Intake Vents
4. Unit Housing
5. Power Cord + Plug
6. Internal Heating Compartment
7. Oven Door
8. Air Outlet Vent

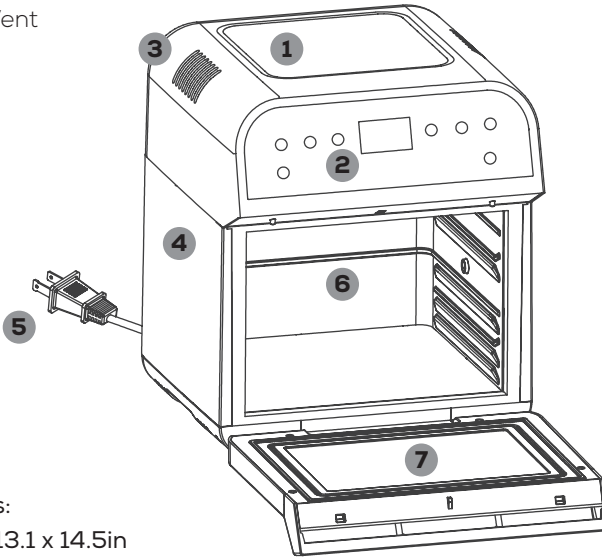

Unit Dimensions:

Outside: 12.4 x 13.1 x 14.5in

Inside: 10.4 x 9.8 x 7.2in

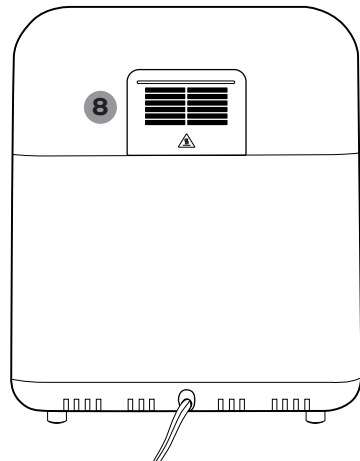

PARTS AND ACCESSORIES

ACCESSORIES

1. Rotisserie Tongs
2. Rotisserie Forks
3. Rotisserie Cage
4. Rotisserie Skewers
5. Rotisserie Steak Cage
6. Wire Rack
7. Shallow Mesh Basket
8. Mesh Tray X2
9. Drip Pan

NOTE: Rotisserie Forks, Rotisserie Cage, and Skewers share one (1) rod.

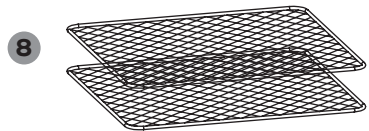
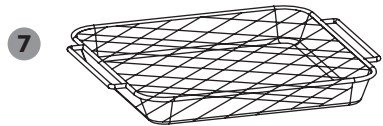
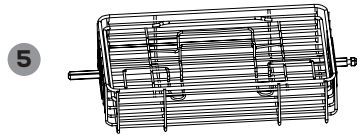
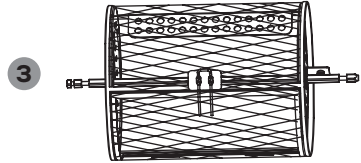
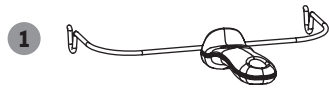

CONTROL DISPLAY

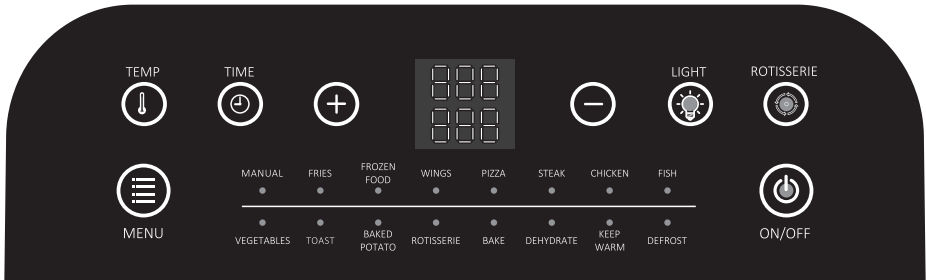

BUTTONS

ON/OFF: Powers the unit on and off; starts and stops cooking process

MENU: Cycles through preset options

ROTISSERIE: Activates the Rotisserie function

LIGHT: Turns the internal cooking light on or off

TEMP: Adjust the temperature of cooking presets

TIME: Adjust the time of cooking presets

+/-: Increases or decreases TEMP and TIME

NOTES:

- Refer to the PRESET CHART of this manual (pg. 16) for detailed TEMP + TIME for each preset.
- If using any of the Rotisserie accessories, make sure the Rotisserie function is activated by pressing ROTISSERIE button on the digital display before starting the cooking process.
- You cannot adjust temperature for the Dehydrate preset.

USING THE DIGITAL CONTROLS

1. Once the unit is plugged in, the display lights will flash once with a single chime/beep.
2. Press the ON/OFF button, and the digital display will light up displaying zero.
3. To select a preset cooking program, press the MENU button repeatedly until desired cooking preset is reached.
4. To adjust a preset's temperature, press TEMP button then press the "+" or "-" buttons to increase or decrease the temperature. The temperature can be adjusted in 10-degree increments.
5. To adjust a preset's cooking time, press TIME button then press the "+" or "-" buttons to increase or decrease the cooking time.
6. Press the ON/OFF button to begin cooking.
7. To make adjustments during the cooking cycle, simply press TEMP or TIME buttons then press the "+" or "-" buttons.
8. To stop cooking after the unit has already started working, press the ON/OFF button once.

SET UP AND USING AIR FRYER OVEN

BEFORE FIRST USE

- 1.** Unbox the unit and place on a countertop or flat surface away from any water source and near a polarized outlet. Before plugging in the unit, remove accessories from the Internal Heating Compartment. Unwrap accessories.
- 2.** Rinse the accessories with warm water and dry thoroughly. Place the Drip Pan at the bottom of the Air Fryer Oven and close the oven door.
- 3.** Plug in the unit. Press the ON/OFF button and set the oven to any cooking preset and follow the steps below:
 - a.** Press TEMP button and using the "+" and "-" buttons set to 350°F
 - b.** Press TIME button and using the "+" and "-" buttons set to 5 minutes
- 4.** Wait for the unit to begin heating
- 5.** This process will burn off any remaining residue left from the manufacturer. There may be a slight burning smell but, will dissipate after a few minutes.
- 6.** Your new **GoWISE Air Fryer Oven Deluxe** is now ready for use!

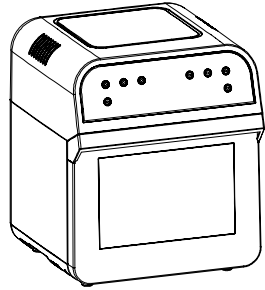

NOTES:

- The **GoWISE Air Fryer Oven Deluxe** will only begin heating once the oven door is completely closed. If the oven door isn't completely shut, an alarm will sound when the ON/OFF button is pushed.
- The oven door can be opened during the cooking process – the unit will stop heating automatically until the door is closed again. The fan will continue to run while the door remains open. If the oven door remains open for 6 minutes, the unit will shut down.

SET UP AND USING AIR FRYER OVEN

USING YOUR ACCESSORIES

Inserting the Drip Pan

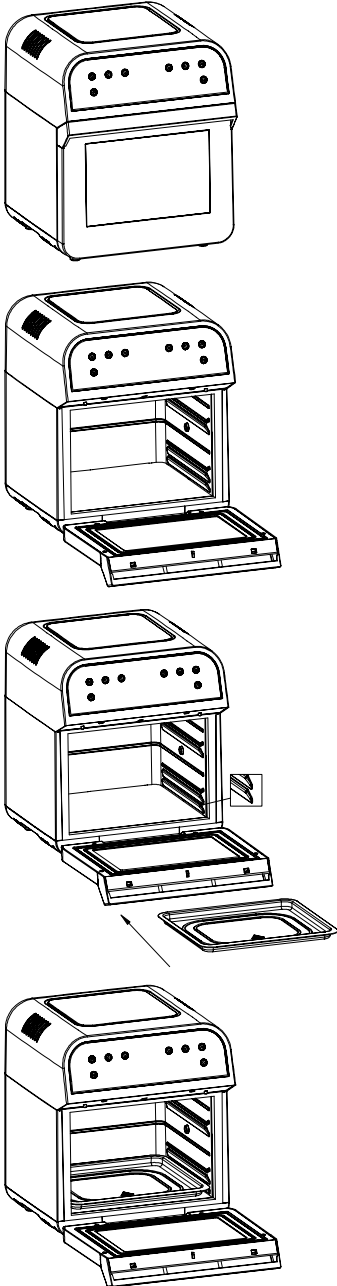

Inserting Wire and Mesh Racks

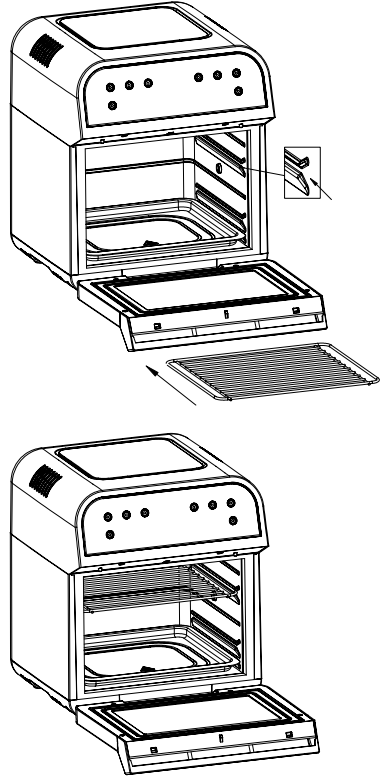

NOTE: Choose the correct cooking rack per cooking application. The mesh rack is perfect for dehydration, but is also great for cooking crispy snacks and reheating pizza. The wire rack tray is best used for holding baking trays at the correct cooking distance from the internal heating element.

SET UP AND USING AIR FRYER OVEN

USING YOUR ACCESSORIES

Rotisserie Steak Cage: Use for cooking tender meats like Fish and Steak.

1. Open Steak Cage by compressing handles of the Rotisserie Steak Cage and lifting the latch side out first.

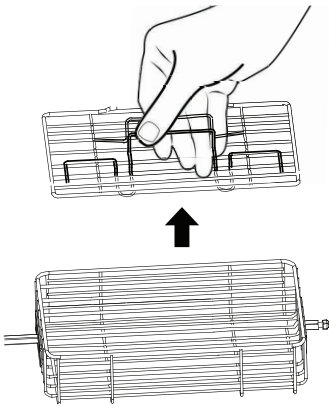
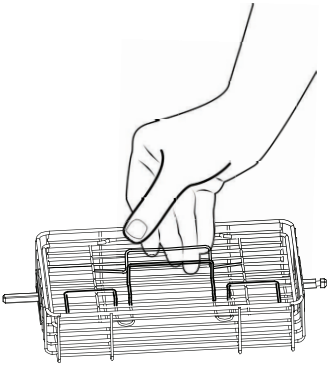

2. Place fish or steak into the cage.
3. Replace the Steak Cage lid, make sure the lid is secure and tight against the meat, so it doesn't flop about while the cage is rotating.
4. Open the oven door. Insert the long end of the Steak Cage into the Rotisserie Socket first. Then, set the opposite end into the Rotisserie slot. Do not force the rod into the socket, rotate until the rod slips in easily.

SET UP AND USING AIR FRYER OVEN

USING YOUR ACCESSORIES

Rotisserie Skewers: Use for cooking Kebabs.

Attaching Rotisserie Rod and Skewer Racks

1. Place the two Skewer Racks at each end of the Rotisserie Rod. Make sure thumb bolts are on the outer side of the Rotisserie Rod.
2. Slightly tighten the thumb bolts. Do not over tighten as you may need to adjust the tightness after inserting Skewers.
3. Carefully poke Skewers through food.

Rotisserie Skewer Assembly

4. Slide a Skewer into an open slot on the edge of the Skewer Rack with the clip facing toward the Rotisserie Rod.
5. Guide the sharp end of the Skewer through the hole on the opposite Skewer Rack and push the clip through the hole near the slot until the Skewer is secure.
6. Repeat steps 3-5 in a uniform manner around the Skewer Rack. Make sure Skewers are evenly spaced.
7. Tighten thumb bolts to make sure they are securely in place.
8. Use caution when inserting Rotisserie Skewers into the unit to avoid being poked by the Skewer tips.
9. Open the oven door. Insert the long end of the Rotisserie Rod into the Rotisserie Socket first then, set the opposite end into the Rotisserie slot. Do not force Rod into the socket; rotate until Rod slips in easily.

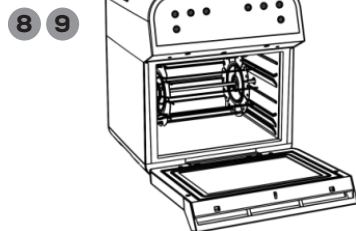
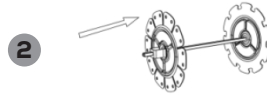
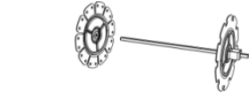

SET UP AND USING AIR FRYER OVEN

USING YOUR ACCESSORIES

Removing Rotisserie Rod, Rotisserie Skewers, and Rotisserie Cage from Unit

1. Open the oven door.
2. While wearing oven mitts on both hands and using the Rotisserie Tongs, hook the bottom left and right sides of the Rotisserie Rod, in the gaps of the rod and carefully lift the rod out of the resting slot on the left side of the oven – carefully pull the rod out of the Rotisserie socket and remove from the oven.

CAUTION! Contents and cooking accessories will be extremely hot after every use. To prevent personal injury, always use oven mitts to remove contents and always wait until the unit has cooled sufficiently before touching or cleaning any area of the Internal Heating Compartment of the Air Fryer Oven.

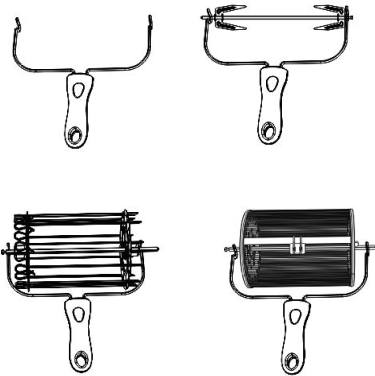

NOTE: Contents will be hot and can easily burn – use caution not to let scalding meat juices or oils from falling on the skin by holding a catch tray or plate under the Rotisserie contents.

COOKING PRESET CHART

Cooking time of a whole roasted chicken may vary depending on weight. Use a meat thermometer to check the internal temperature as per the chart on page 17.

Preset	Default Temperature	Default Time
Fries	430°F	15 min
Frozen Food	340°F	20 min
Wings	400°F	15 min
Pizza	350°F	10 min
Steak	400°F	12 min
Chicken	430°F	25 min
Fish	360°F	15 min
Vegetable	400°F	10 min
Toast	400°F	5 min
Baked Potato	400°F	40 min
Rotisserie	400°F	35 min
Bake	350°F	30 min
Dehydrate	130°F	8 hr
Keep Warm	150°F	30 min
Defrost	120°F	30 min
Manual	Optional	Optional



WARNING

Never use a cooking vessel filled with cooking oil or any other liquid with this Unit! Fire Hazard or personal injury could result.

INTERNAL TEMPERATURE CHART

This chart should be used to check the temperature of cooked meats. Always review USDA Food Safety Standards.

Food	Type	Internal Temperature
Beef + Veal	Ground Steaks, Roasts: Medium Steaks, Roasts: rare	160°F (70°C) 160°F (70°C) 145°F (63°C)
Chicken + Turkey	Breasts Ground, Stuffed Whole bird, legs, thighs, wings	165°F (75°C) 165°F (75°C) 165°F (75°C)
Fish + Shellfish	Any type	145°F (63°C)
Lamb	Ground Steaks, Roasts: medium Steaks, Roast: Rare	160°F (70°C) 160°F (70°C) 145°F (63°C)
Pork	Chops, Ground, Ribs, Roasts Fully cooked Ham	160°F (70°C) 140°F (60°C)

TRUSSING A WHOLE CHICKEN

1. Finding the right size chicken
– be careful not use a chicken exceeding the 5 lbs max.
2. After preparing, i.e., seasoning the chicken, truss the chicken using butcher's twine.
 - a. Place the chicken on its back with the legs facing toward you.
 - b. Slide a piece of twine under the back of the chicken between the wings and the thighs.
 - c. Pull both ends of the twine up under the chicken's armpits, then pull them over the wings.
 - d. Cross the string around the top of the breast, making sure the skin is secure.
 - e. Bring the ends of the twine back toward you, running them along the sides of the breast above the wings and thighs.

a



b



c



d



e



TRUSSING A WHOLE CHICKEN

- f. Cross the ends of the twine, pulling tightly up and under the crown of the bird.
- g. Loop the ends of the string under the legs, then over the top of the legs. Cross and tighten. The thighs should pop up a little.
- h. Flip the bird onto its belly and finish by tying the strings in a knot around the tail. Snip off the ends.



f

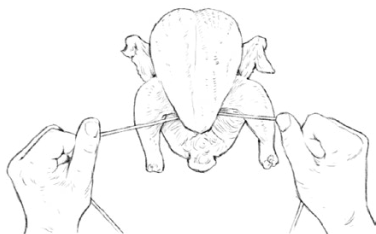

g

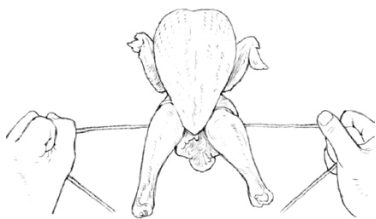
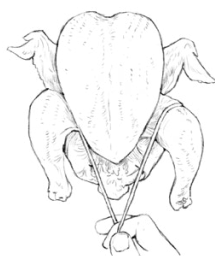

h



ROTISSERIE ROAST A WHOLE CHICKEN

Using the Rotisserie Rod to Roast a Whole Chicken

1. After the chicken is trussed, carefully maneuver the Rotisserie Rod through the chicken from the neck to the legs.
2. Slide the Rotisserie Forks on both sides of the Rotisserie Rod piercing the chicken; making sure to secure the chicken in place.
3. Using the Thumb Bolts, lightly tighten the Rotisserie Forks into place – Do not over tighten as removing Rotisserie Forks may become difficult after cooking.
4. Open the oven door. Insert the long end of the Rotisserie Rod into the Rotisserie Socket first then, set the opposite end into the Rotisserie slot. Do not force the rod into the socket, rotate until the rod slips in easily.
5. Turn the unit on by pressing the ON/OFF button and select the Rotisserie preset by cycling through MENU.
6. Press ROTISSERIE button on the Digital Display to engage the rotation functionality of the oven.
NOTE: The default cooking temperature and time for Rotisserie is 400°F for 35 min – if the chicken is not golden brown and crispy and the internal temperature is not 165°F, repeat the cooking cycle.

7. When the chicken is done cooking with the internal temperature of 165°F, remove the chicken using the Rotisserie Tong.
 - a. Open the oven door.
 - b. While using oven mitts and using the Rotisserie Tong, hook the bottom left and right sides of the Rotisserie Rod, in the gaps of the rod and carefully lift the rod out of the resting slot on the left side of the oven – carefully pull the rod out of the Rotisserie socket and remove from the oven.

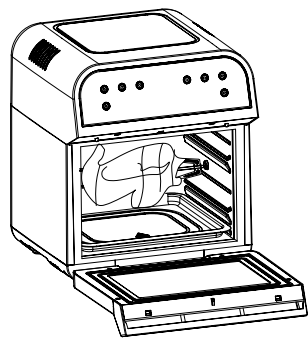
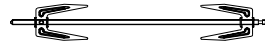

NOTE: Contents will be hot and can easily burn – use caution not to let scalding meat juices or oils from falling on the skin by holding a catch tray or plate under the Rotisserie contents.

TROUBLESHOOTING & ERROR CODES

Problem	Solution
Why won't my air fryer oven turn on?	First, make sure the air fryer oven is plugged in and the oven door is closed. You can also try using different outlets if it's still not turning on. If none of these solve the problem, please contact our Customer Care Team.
My food is not cooked all the way / My food doesn't seem crispy enough	Your oven may be overfilled with ingredients. Cook in smaller batches for more even cooking.
	You may have the temperature set too low. Increase the temp. and continue cooking (see pg. 17).
	For a crispier effect, brush with oil before air frying.
	Try flipping or rotating your food over midway through the cooking cycle. This will ensure even cooking
White smoke is coming out of my air fryer oven. Should I be worried?	It's normal for white smoke to appear when prepping greasy ingredients. When frying greasy ingredients, a large amount of oil will leak into the pan. The oil produces white smoke and the oven may heat up more than usual. This does not affect the appliance or end food result. Be sure to clean your oven properly after each use to prevent it from smoking during the next use. It helps to wipe down the heating element as well.
How do I stop the cooking cycle on my air fryer oven?	Press the POWER button to completely stop your cooking cycle. The fan will continue running for about 20 seconds to cool down the unit.

ERROR CODE	ISSUE
E1	Sensor open circuit
E2	Touch sensors short circuit
E3	Circuit board connection error

If your GoWISE USA Air Fryer Oven displays any of these error codes, please contact Customer Care Team.

855-233-9199

support@gowiseusa.com

Live Chat at gowiseusa.com

M-F 8:30am - 4:00pm MST

WARRANTY

GoWISE USA warrants all products against defects in materials and workmanship for **one (1) year** effective from the date of purchase.

GoWISE USA will replace any products that are found to be defective due to manufacturer flaws based on eligibility. Refunds issued by GoWISE USA must be purchased directly from GoWISE USA and are only available to the original purchaser within the first 30 days. We do not issue refunds for items bought by thirdparty retailers.

This warranty extends only to personal use and does not extend to products that has been used for commercial, rental or any other use this product was not intended for. There are no warranties other than the warranties expressly set forth with each product.

This warranty is non-transferrable. GoWISE USA is not responsible in any way for any damages, losses, or inconveniences caused by equipment failure by user negligence, abuse, or use noncompliant with the user manual or any additional safety, use, or warnings included in the product packaging and manual.

This warranty only covers purchases within the 48 contiguous states of United States of America. For purchases made outside the 48 contiguous states, such as AK, HI, PR, or Canada, we will replace the unit under the one-year warranty upon receipt of a proven defect by video or picture. However, the replacement will only ship to a freight forwarder or address within the 48 contiguous United States. The consumer is responsible for arranging shipment outside of the 48 contiguous states.

GoWISE USA assumes no liability for damage caused using this product other than for its intended use or as instructed in the user manual. Some states do not allow this exclusion or limitation of incidental or consequential losses, so the foregoing disclaimer may not apply to you. This warranty gives you specific legal rights and you may also have other rights which may vary from state to state.

ALL EXPRESSED AND IMPLIED WARRANTIES INCLUDING THE WARRANTY OF MERCHANTABILITY, ARE LIMITED TO THE PERIOD OF THE LIMITED WARRANTY.

NOTE: General Warranty excludes refurbished / auction items.

This warranty does not cover products that are purchased in the following conditions:

- Open Box
- Like New
- Used
- Renewed

WARRANTY

Additional 60-Days Warranty

You can extend your 1-year warranty by an additional 60 days. Log onto [www.gowiseproducts.com/apps/ product-registration](http://www.gowiseproducts.com/apps/product-registration) and register your product within the first 14 days of your purchase for the extended warranty.

DEFECTIVE PRODUCTS & RETURNS

If your product is defective within the 1-year warranty period, please email our Customer Care Team at support@gowiseusa.com. To expedite your issue, please provide the 4 items below:

1. Copy of the invoice, order information, or gift receipt showing the date of purchase
2. Serial number, usually found on a sticker located on the bottom on back of the unit
3. Picture or video of the issue or defect that you are experiencing
4. Shipping address information

Authorized Retailers:

Amazon

GoWISE USA

WayFair

Houzz

Home Depot

etailz

MorningSave.com

Bed Bath & Beyond

Jet.com

Walmart.com

Macy's

kroger.com

weightwatchers.com

GoWISEUSA®

WWW.GOWISEUSA.COM

855-233-9199

support@gowiseusa.com

Live Chat at gowiseusa.com

M-F 8:30am - 4:00pm MST

- To ensure the correct use of this appliance, read these instructions carefully and thoroughly.
- Please keep this manual for future reference.
- Thank you for purchasing this GoWISE USA Air Fryer Oven.

USE PROMO CODE: **LIVewiseraF**

**10%
OFF**

YOUR NEXT **GoWISEUSA®** PURCHASE

