

 Kolibri™

KOLIBRI BILL COUNTER

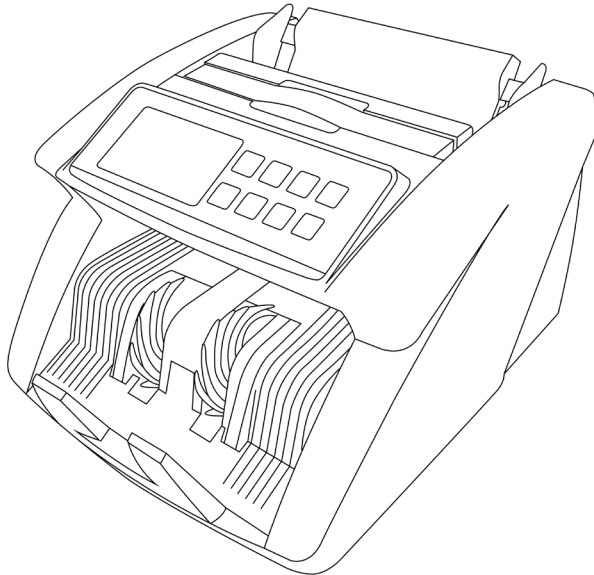

USER MANUAL

Kolibri Automatic Bill Counter

This manual contains important information on safety measures and operational features of the Kolibri Automatic Bill Counter. Please read it carefully before operating your machine and keep it for future reference. While every effort has been made to include all features into this user manual, specifications stated may not reflect all features of the latest software versions. If you have any questions about your Kolibri Automatic Bill Counter and its operation, please contact technical support at www.kolibriusa.com/contact/.



**CHOKING HAZARD.
SMALL PARTS**

Not for children under
3 years old.



**WARNING: RISK OF
ELECTRICAL SHOCK.**

This equipment is to be serviced
by trained personnel only.



**DO NOT DISPOSE
IN TRASH.**

Follow appropriate local
electronics scrap procedures.



**WARNING: HAZARDOUS
MOVING PARTS**

Do not place fingers, hair,
clothes, lanyards...
near moving parts.



PROP 65 WARNING. This product may contain chemicals known to the State
of California to cause cancer, or birth defects or other reproductive harm.

<https://oehha.ca.gov/>

Table of Contents:

1. INTRODUCTION

1.1 About the Kolibri Automatic Bill Counter	1
1.2 Important Safety Notes	1
1.3 Box Contents	2
1.4 Product Specifications	2
1.5 Views of the Kolibri Automatic Bill Counter	3
1.6 Control Panel	4
1.7 Home Screen	5

2. GETTING STARTED

2.1 Powering Up	6
2.2 Loading the Hopper	6
2.3 Carrying the Unit	8

3. OPERATING MODES AND FUNCTIONS

3.1 Auto & Manual Mode	8
3.2 Count Mode	9
3.3 Add Mode	9
3.4 Batch Mode	9
3.5 Add + Batch Mode	10

4. DETECTION FEATURES

4.1 UV Counterfeit Detection	10
4.2 MG Counterfeit Detection	11
4.3 IR Detection	11
4.4 Half Note Detection	11
4.5 Double Note Detection	12
4.6 Chain Note Detection	12

5. MAINTENANCE, TROUBLESHOOTING AND SERVICE

5.1 Maintenance	13
5.2 Feed Gap Adjustment	16
5.3 Sensitivity Settings	18
5.4 Troubleshooting	19
5.5 Warranty	22
5.6 Contact Information	23

1. INTRODUCTION

1.1 About the Kolibri Automatic Bill Counter

Thank you for choosing the Kolibri Automatic Bill Counter.

The Kolibri Automatic Bill Counter is a cash processing machine that is sophisticated, but simple to operate. It saves time and reduces counting errors by swiftly and precisely counting stacks of bills at the speed of 1500 bills per minute. The Kolibri Automatic Bill Counter also comes with many built-in features and reliable counterfeit detection while maintaining high level performance.

1.2 Important Safety Notes

When using this product, basic safety precautions should always be followed, including the following:

- Do not use this product in areas where it may be exposed to water or any other liquids.
- Unplug this product from the wall outlet before cleaning. Use a damp cloth or air duster to clean the unit.
- To avoid the risk of electrical shock, do not disassemble this unit. Disassembling will expose you to dangerous voltages and other safety risks. Incorrect reassembly may cause electrical shock when the unit is subsequently used.
- Only use this product with the power cord supplied with it. Plug the power cord into a properly grounded wall outlet. Do not remove the grounding pin from the power cord. Failure to properly ground the unit can result in severe injury or fire.
- Make sure the device is placed on a flat surface. Do not operate the unit in areas with high temperature, humidity or smoke as these conditions may impede performance.
- This product is designed for indoor use in a well-ventilated environment. Keep the unit away from direct sunlight and strong magnetic fields which may interfere with the counterfeit detection sensors.
- When not using the unit for an extended period of time, disconnect the power cord from the wall outlet.

1.3 Box Contents

- Kolibri Automatic Bill Counter
- External Display
- Power Cord
- User Manual
- Accessories

1.4 Product Specifications

Counting speed: 1500 bills per minute

Hopper capacity: 200 bills

Stacker capacity: 200 bills

Weight: 10.6 lbs (4.8 kg)

Dimensions: 11.4" x 9.8" x 6.9" (290mm x 250mm x 175mm)

Power source: AC 100V, 60Hz, < 80W

1.5 Views of the Kolibri Automatic Bill Counter

1. Hopper
2. Bill Guides
3. Carrying Handle
4. Control Panel
5. Screen
6. Stacker
7. Feed Gap Adjuster
8. Power Switch
9. RS-232M Port
10. Fuse
11. AC Power

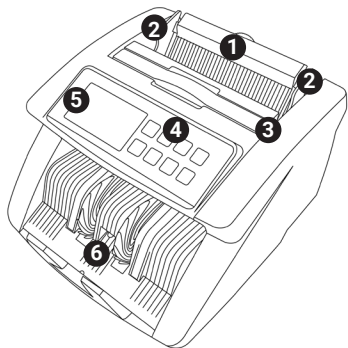

FRONT VIEW

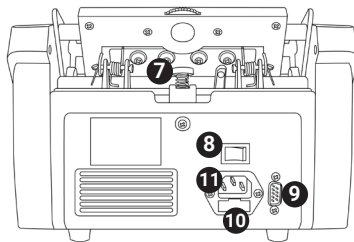

BACK VIEW

1.6 Control Panel

Key	Function
1. Display	Shows the number of bills counted, error codes, modes, and settings that are active.
2. MG+ Counterfeit Detection Button	Activates/Deactivates magnetic (MG) counterfeit detection. "+" Customizes the batch according to user's needs when on a BATCH function.
3. UV- Counterfeit Detection Button	Activates/Deactivates ultraviolet (UV) counterfeit detection. "-" Customizes the batch according to user's needs when on a BATCH function.
4. ADD Button	Activates/Deactivates ADD mode
5. BAT Button	Activates/Deactivates BATCH mode
6. A/M Button	Activates Auto or Manual count start
7. SET Button	Sensitivity Settings
8. CLEAR Button	Resets the count
9. START Button	Starts the count

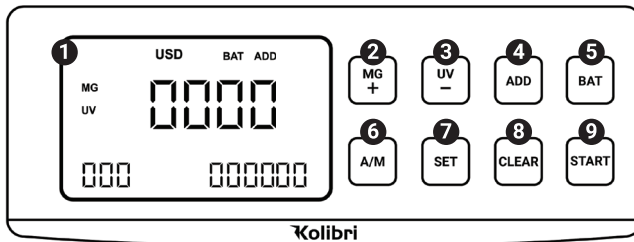

1.7 Home Screen

1. USD - Currency
2. BATCH Function (Activated)
3. ADD Function (Activated)
4. Number of Bills Counted
5. Total Number of Bills Counted
6. Selected Batch Amount (Activated)
7. UV Detection (Activated)
8. MG Detection (Activated)

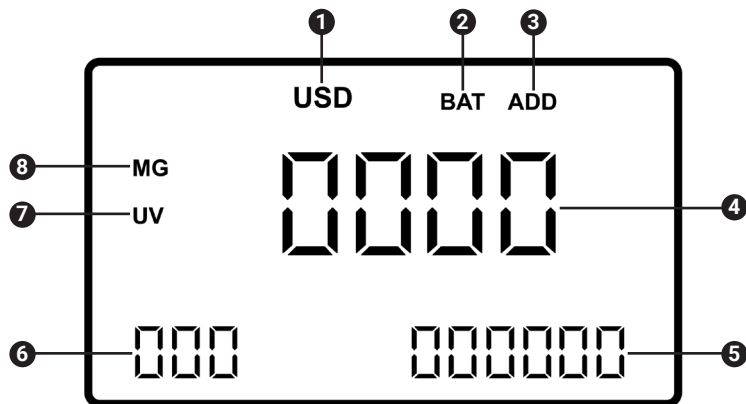

2. GETTING STARTED

2.1 Powering Up

Ensure the hopper and stacker are empty. Then, attach the provided power cable to the power inlet on the back of the machine. Make sure to plug the power cable into a three-prong outlet and turn on the power switch located on the back of the machine .

The unit will load and conduct a self-checking. The screen will display “0” when the unit is ready to operate.

2.2 Bill Loading

In order to avoid jams, it is important to correctly load the hopper. Kolibri recommends not to use more than 200 bills at a time. Follow the 3-step loading technique below to ensure smooth bill feeding.

WARNING: Hazardous moving parts!

Do not place fingers, hair, clothes, etc. near the moving parts.

STEP 1:

Correct or remove the bills that are severely wrinkled, damaged or folded. Square the bill stack.

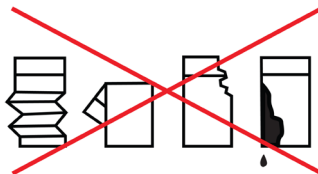

STACK IT

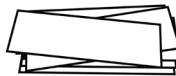

STEP 2:

Place the bill stack on the carrying handle, with the bottom of the stack touching the bill guide plate. As it is shown in the illustration.

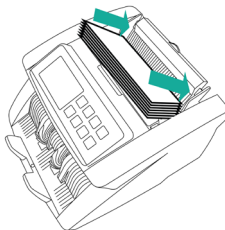
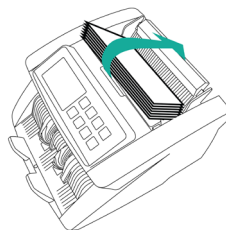
PLACE IT**FLIP IT****STEP 3:**

Flip the bill stack towards the rear of the machine so the stack is now leaning against the bill guide plate. The bills will load automatically (unless in manual mode).

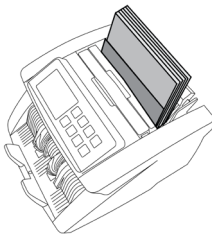

Below is a side view of the bill loading technique. All bills must be between the rollers and the feeding plate to be counted smoothly.

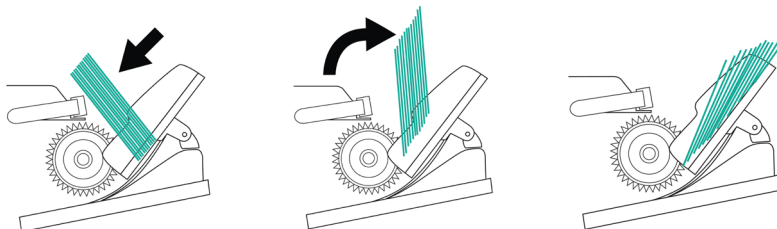

2.3 Carrying the Unit

1. Grasp the handle.

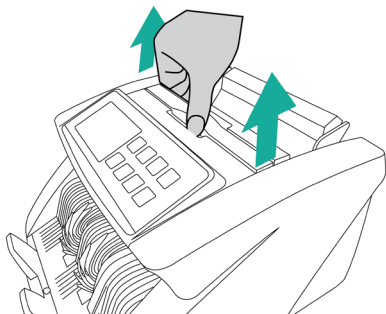

2. Pull the handle up.

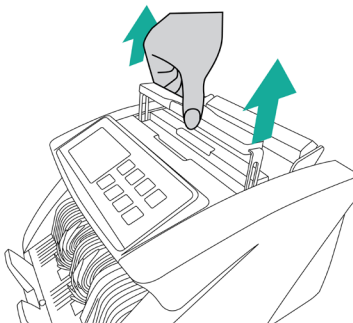

3. OPERATING MODES & FUNCTIONS

3.1 Auto & Manual Mode

After turning the machine on for the first time it will default to AUTO mode. In this mode the machine starts counting automatically. To operate in MANUAL mode, press the "A/M" button on the control panel. Machine will beep twice, indicating that MANUAL mode is activated. If the machine is set to operate in MANUAL mode, it will stop counting automatically; the "START" button must be pressed to begin each count. To go back to AUTO mode, press "A/M" button again. Machine will beep once indicating activation of the AUTO mode.

3.2 Count Mode

After turning the machine on it will default to count mode. To count bills, place them in the hopper and follow the procedure described in 2.2 Bill Loading. The machine will start counting automatically (if in AUTO mode) and move the bills from the hopper to the stacker as it counts them. The machine will stop counting when the hopper is completely emptied and the counted number of bills will be displayed on the screen. Remove the bills from the stacker and place another stack into the hopper to count another batch of bills. When the bills are removed from the stacker the screen will clear itself of the previous count, or it can be cleared by pressing the "CLEAR" button.

3.3 Add Feature

This feature is available by pressing the "ADD" button. When this function is activated, an "ADD" indicator is displayed on the home screen. The machine counts multiple stacks of bills and keeps track of the total number of bills will be displayed on the bottom right corner of the screen. When ready to count the next stack of bills, empty the stacker and load the new stack to be counted into the hopper. The unit will continue counting and add the new count to the total. To exit ADD mode, press the "ADD" button again.

3.4 Batch Feature

This feature is available by pressing the "BAT" button. When this function is activated, the "BAT" indicator will be displayed on the screen along with the batch size. The machine counts a preset number of bills. It beeps and stops counting when the batch number has been reached, even if bills remain in the hopper. By default, the batch size is preset to 100. You may press the "BAT" button repeatedly to cycle through different preset batch quantities (100, 50, 20, 10), or use the "MG/+" and "UV/-" buttons to manually select a desired batch size. To exit the BATCH function, press the "BAT" button until the "BAT" indicator disappears from the screen.

3.5 Add + Batch Feature

This feature batches the desired quantity of bills and monitors the running total at the same time. To activate this function, press the “ADD” and “BAT” button until both the “BAT” and the “ADD” indicators are displayed on the screen. By default, the batch size is preset to 100. Use the “MG/+” and “UV/-” buttons to manually select your desired batch size. To exit the ADD+BATCH feature, press the “ADD” and “BAT” buttons until the indicators on the screen disappear.

4. DETECTION FEATURES

4.1 UV Counterfeit Detection

The Kolibri Automatic Bill Counter can identify bills suspected of being counterfeit using an ultraviolet light detection system. This function is available in all modes by pressing the “UV” button until the “UV” indicator is displayed on the screen.

When a suspect bill is detected, the unit will stop, beep and display the error code “E01” on the screen. The unit will not stop beeping or start until the suspect bill is removed from the stacker, and the “START” button is pressed. The suspect bill will not be added to the count.

Please note that a suspect UV bill does not necessarily mean that the bill is counterfeit. There are several reasons a genuine bill may be recognized as counterfeit. Possible reasons for a bill to be indicated as suspect include: detergent washed bills, direct sunlight exposure, worn out bills, excessively dirty bills or advanced counterfeiting techniques used to produce the bill. Separate equipment may be required to determine definitively whether a note is counterfeit.

4.2 MG Counterfeit Detection

The Kolibri Automatic Bill Counter can identify bills suspected of being counterfeit by utilizing magnetic ink detection. This function is available in all modes by pressing the “MG” button until the “MG” indicator is displayed.

When a suspect bill is detected, the unit will stop, beep and display the error code “E02” on the screen. The unit will continue to beep until the suspect bill is removed from the stacker, and the “START” button is pressed. The suspect bill will not be added to the count.

Please note that a suspect MG bill does not necessarily mean that the bill is counterfeit. There are several reasons a genuine bill may be recognized as counterfeit. Possible reasons for a bill to be indicated as suspect include: worn out bills, excessively dirty bills or advanced counterfeiting techniques used to produce the bill. Separate equipment may be required to determine definitively whether a note is counterfeit.

4.3 IR Detection

The Kolibri Automatic Bill Counter can identify bills by their size and thickness utilizing infrared detection. By default, this function is always on in all modes in order to identify half note, double note, or chain note errors.

4.4 Half Note Detection

The Kolibri Automatic Bill Counter incorporates infrared light sensors that notify users if a half note passes through the counting mechanism. This function is activated automatically in all modes. If the unit detects a half note, it will stop, beep and display the error code “HLF” on the screen. The unit will continue to beep until action is taken. To clear the error, all bills must be removed from the stacker and recounted.

4.5 Double Note Detection

Bills may stick to each other due to excessive dirt, folding or various other reasons. The Kolibri Automatic Bill Counter uses infrared light sensors to determine whether two bills are stuck together. This feature is active automatically in all modes. If a double bill is encountered the unit will stop, beep and display the error code “dbL” on the screen. The unit will continue beeping until action is taken. To clear the error, all bills must be removed from the stacker and recounted.

4.6 Chain Note Detection

The Kolibri Automatic Bill Counter utilizes infrared light sensors and a self checking system that alerts the user in rare cases when several notes pass through the counting mechanism at once. This feature is activated in all modes. If the unit detects a chain error, it will stop, beep and display the error code “CHn” on the screen. The unit will continue beeping until action is taken. To clear the error, all bills must be removed from the stacker and recounted.

5. MAINTENANCE, TROUBLESHOOTING AND SERVICE

5.1 Maintenance

ATTENTION: Always power off the unit and disconnect from power source before cleaning.

Most operational problems can be avoided by regular care and preventative maintenance. Taking regular care of the Kolibri Automatic Bill Counter will significantly increase its lifetime.

All parts of the Kolibri Automatic Bill Counter need daily care and cleaning. Pay closed attention to the sensors, which are delicate components. If only dust or other foreign matter adheres to the sensors, it may cause various problems during operation of the machine. Dirty sensors can affect the Kolibri's Automatic Bill Counter's performance and cause genuine bills to be rejected. It is suggested that the user performs weekly maintenance on the unit to maintain top performance.

For best results, it is recommended to use an air duster and a soft bristle brush to remove any dust or debris from the interior of the unit. When not using the machine for an extended period, cover it with the provided dust cover to prevent dust from settling inside.

- To avoid malfunction caused by foreign objects, please clean your machine frequently
- Clean Hopper and Stacker sensors with the provided soft bristle brush or a dry cloth frequently
- Clean the sensors with the provided soft bristle brush or a dry cloth frequently
- Rubber rollers may be cleaned with a slightly damp cloth. You may use a small amount of isopropyl alcohol to dampen the cloth and clean the rollers. Wait until the rollers are completely dry before turning on the machine.

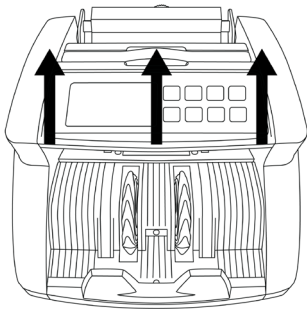

1. Place fingers under control panel and thumbs on the side panels.

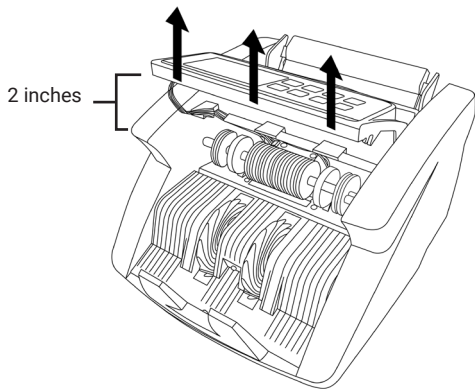

2. Lift control panel about 2 inches.

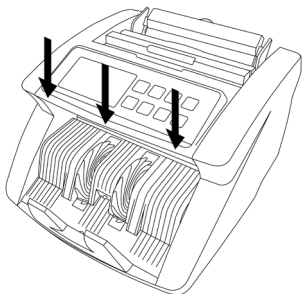

3. Secure sensor housing and control panel back to the initial position.

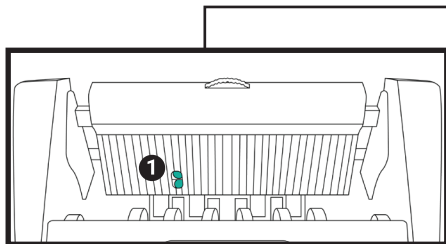

1. Hopper Sensor
2. Infrared Sensor (IR)
3. Ultraviolet Sensor (UV)
4. Magnetic Sensor (MG)
5. Stacker Sensor

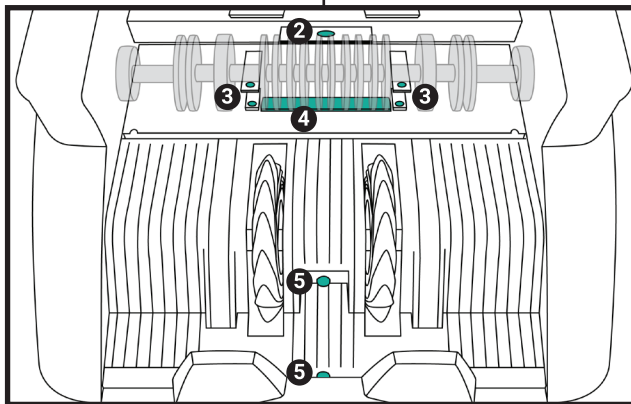
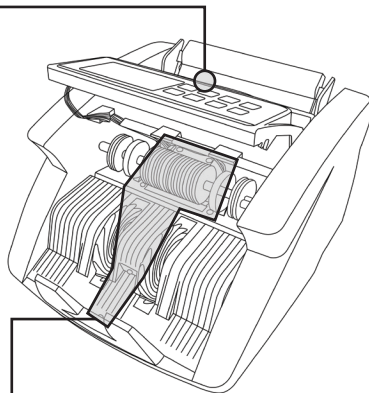

5.2 Feed Gap Adjustment

Sometimes, during the transportation or shipment of the unit, the adjustments of the feed mechanism may loosen. This can also happen during normal wear and tear, and can lead to DOUBLE/CHAIN errors.

The feed gap is the actual height of the bill feed path and should be turned to just about the thickness of a single bill. If the feed gap is too wide, the user may experience a high amount of DOUBLE/CHAIN errors which are caused by more than one bill entering the scanning path at one time. If the feed gap is too tight, the unit may not be able to pass bills into the scanning path or catch on bills and tear them.

To adjust the feed gap properly, you will need a philips screwdriver (not included).

1. Ensure the machine is turned off.
2. Locate the feed gap adjustment knob (green) and the fixing plate screw (green circle) at the back of the machine (loosen before performing any adjustment)

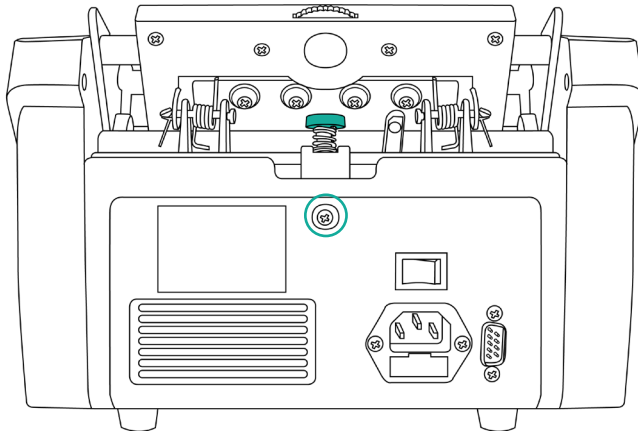

- 3a. If more than one bill is being pulled into the feed mechanism (Double/Chain errors), turn the knob clockwise (decrease gap Adjust 1 turn, then re-test the machine to see if the problem is corrected. Repeat if necessary.

Clockwise

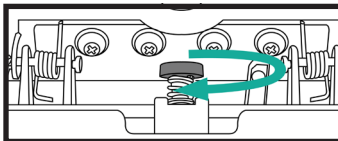

NOTE: If the feed gap is adjusted too narrow, chain error, bill jams and tears can occur.

- 3b. If Chain error or bill jamming is seen on the input, turn the knob counterclockwise (increase gap). Adjust 1 turn, then re-test the machine. Repeat as necessary.

Counterclockwise

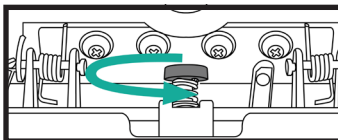

NOTE: If the feed gap is adjusted too wide, double and half errors can occur.

4. Fix the adjusted position by tightening (clockwise) the fixing plate screw.

Fixing Plate & Screw

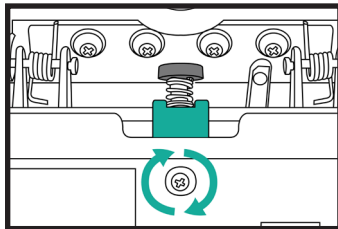

IMPORTANT NOTE:

The Kolibri Automatic Bill Counter's feed gap adjustment can be sensitive during adjustments. DO NOT overturn each adjustment or you may overshoot the optimum gap. We recommend testing with a stack of bill after each adjustment turn.

5.3 Sensitivity Settings

In order to enter the sensitivity settings menu, press and hold the “SET” button for 3 seconds, or until “-C00” code displays in the bottom right corner of the screen. Press the “BAT” button to cycle through the different codes (refer to the Sensitivity Codes Table). When on the desired code you can use the “MG+” button or the “UV-” button to adjust the settings accordingly. Once adjusted, place a finger on the hopper sensor to save and exit the sensitivity settings menu. Codes are listed below for reference.

SENSITIVITY CODES TABLE

CODE	DETAIL	SETTING	ADJUSTMENT
C00	Voice Switch	0	0 = off / 1 = on
H-C01	Voice Volume	1	0 = off / larger number = louder sound
-C04	External Display	1	0 = off / 1 = on
H-C07	Stop Line	40	larger number = quicker stop
-C08	Alarm Last Time	0	0 = shut / 1 = open
H-C09	Hopper Sensor Sensitivity	150	larger number = higher sensitivity
H-C10	Stacker Sensor Sensitivity	125	larger number = higher sensitivity
-C24	Double Note Sensitivity	20	larger number = higher sensitivity
-C25	UV Sensor Sensitivity	120	0 = close / larger number = higher sensitivity
-C26	MG Sensor Sensitivity	5	0 = close / larger number = higher sensitivity
-C28	Counting Threshold	220	
-C35	Button Beep	1	0 = off / 1 = on

5.4 Troubleshooting

In order to enter the sensitivity settings menu, press and hold the “SET” button for 3 seconds, or until “-C00” code displays in the bottom right corner of the screen. Press the “BAT” button to cycle through the different codes (refer to the Sensitivity Codes Table). When on the desired code you can use the “MG+” button or the “UV-” button to adjust the settings accordingly. Once adjusted, place a finger on the hopper sensor to save and exit the sensitivity settings menu. Codes are listed below for reference.

Error Message Display:

ERROR MESSAGE	CAUSE	SOLUTION
E01	Suspect bill detected by ultraviolet detection or UV detection issue.	Remove top bill from stacker. This bill is not added to count. Press start to continue.
E02	Suspect bill detected by magnetic detection or MG detection issue.	
CHn	Two or more bills passed as one.	Ensure bills are loaded properly. Remove all bills from stacker. Bills are not added to the total count. Recount.
HLF	The last counted bill does not confirm size of the bill or the bill might be torn or folded.	Ensure top bills in the stacker are standard size and or not folded. Remove all bills from stacker. Bills are not added to the total count. Recount.

Error Message Display (continued):

ERROR MESSAGE	CAUSE	SOLUTION
dbL	The last counted bill is a double note or has double detection issue.	Ensure top bills in stacker are not stuck together. Remove all bills from stacker. Bills are not added to the total count. Recount.
FE3	Issue with the left counting sensor.	Clean the sensor. See section 5.1 Maintenance for location of sensors.
FE2	Issue with the right counting sensor.	
FE7	Issue with the encoder sensor.	
FE1	Issue with the feeding sensor.	
FE6	Issue with the stacker sensor.	
FEA	Issue with the UV sensor.	

Other Possible Errors:

PROBLEM DESCRIPTION	CAUSE/ACTION
Machine does not turn on.	Ensure the power cord is connected properly. Check the fuse in the fuse compartment and replace it if necessary. Contact Kolibri's technical service center if the issue persists.
Machine fails to detect counterfeit notes.	<ol style="list-style-type: none">1. Bills were incorrectly inserted into the hopper.2. Turn off the machine and turn it back on.3. The feed gap is too wide. This may happen when brand new notes are counted as their thickness differs greatly from used notes to which the machine's gap is adjusted for by default. Narrow the gap slightly by turning the feed gap adjuster (refer to section 1.5, rear and front view) counterclockwise by one turn at a time and try counting again. Repeat the procedure until a suitable gap width is reached. If the resistance against the bill feels too strong, loosen the gap by turning the screw clockwise.
Bills are jammed.	Turn off the machine. Remove any jammed bills. Look for any foreign objects inside the unit (paper clips, rubber bands, etc.). Remove foreign objects, if any. Recount.

5.5 Warranty

The Kolibri Automatic Bill Counter is warranted for a period of one year from the date of purchase.

In most cases a unit malfunction can easily be corrected by performing a thorough cleaning.

- Customer should allow the manufacturer the time and opportunity to test and diagnose the machine to determine warranty and non-warranty claims.
- After receiving and unpacking the unit, customer shall keep the package and its user manual. Warranties are canceled in the event the device is transported in a non original packaging or operation/maintenance conditions are not met.
- Company is not responsible for unit malfunction due to improper maintenance, storage, or transportation including, but not limited to mechanical damage.
- Manufacturer is entitled to introduce updated software, not described in the current user manual.

Non-Warranty Service:

The manufacturer can perform maintenance and cleaning for an extra fee. For a non-warranty repair or maintenance quotation, contact our Technical Support team.

Warranty service is not available in the following cases:

- Cleaning of the unit from dust and mud.
- Operation or maintenance rules requirements set in the user manual are not met.
- There is mechanical damage to the unit, or the sealed portions of the unit have been opened or tampered with.
- There are foreign objects or liquid inside the unit.

5.6 Contact Information

Technical Support contact information:

<http://kolibriusa.com/contact/>

When contacting Technical Support, please have the following available:

- Product Model - Located on the back of the machine.
- Serial Number - Located on the bottom of the machine.
- Nature of the problem - What happened, and when did it happen? Did the machine display an error message?
- Steps already taken to resolve the problem and the results.

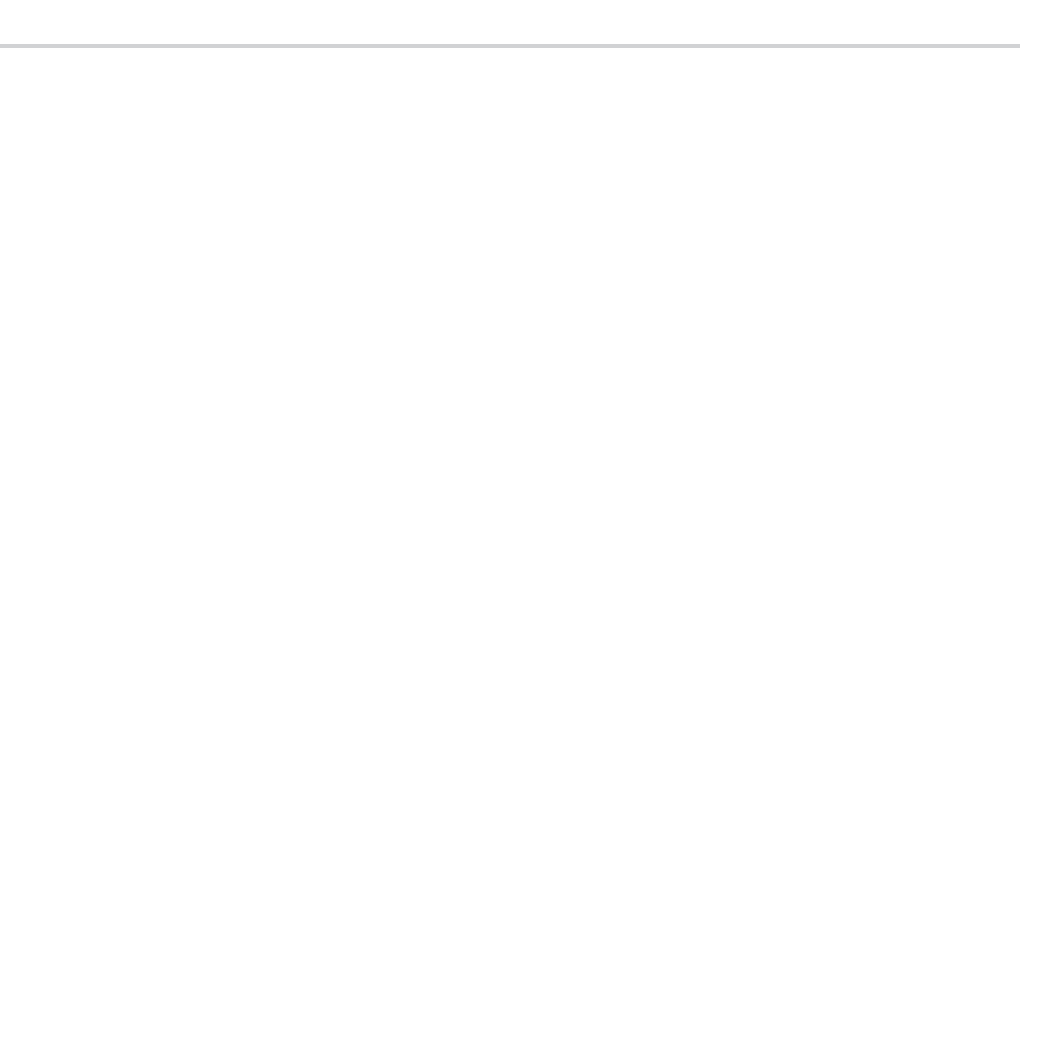

Kolibri™

©2020 Printed in China.

Specifications subject to change without notice.

www.KolibriUSA.com

KKR12032020