







INSTRUCTION MANUAL

Model: C-1368-1B

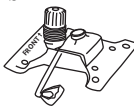
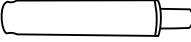
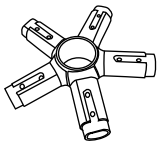
Package List

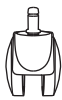
- Without further ado, we kindly suggest you to list all parts needed for the chair first.

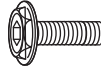
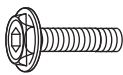
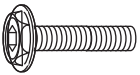
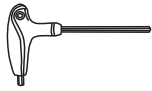
(1)*1 Backrest 	(2)*1 Seat Cushion 	(3)*1(L)*1(R) Armrests 
(4)*1 Mechanism 	(5)*1 Gas Lift 	(6)*1 Base 
(7)*5 Legs 	(8)*5 Casters 	(9)*10 Bolts 
(10)*4 Bolts 	(11)*4 Bolts 	(12)*6 Bolts 
(13)*1 Wrench 		

Assembly Instruction

• Step 1:

Turn the Base **(6)** upside down, then insert Base Legs **(7)** one by one to Base. Use the Wrench **(13)** to screw Ten Bolts **(9)** into the pre-drilled screw holes to fix the Base and the Base Legs.

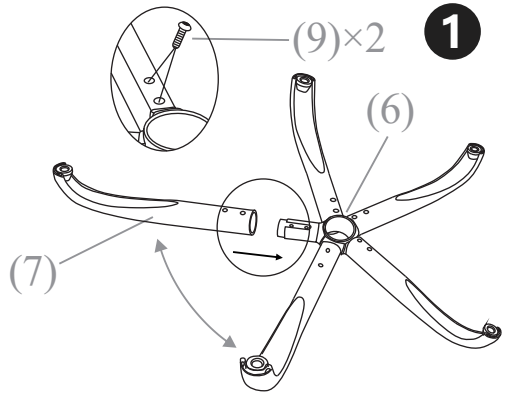

• Step 2:

Both hands are forced at the same time to press the Casters **(8)** into the holes at the end of each Base Leg.

2

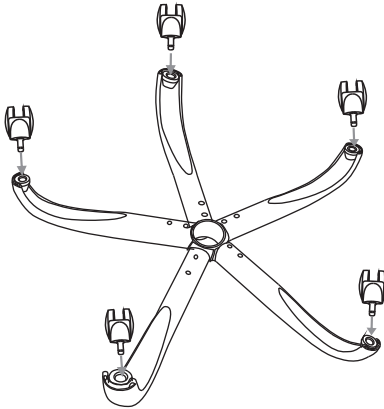

• Step 3:

Insert the Gas Lift **(5)** into the center hole of the Base.

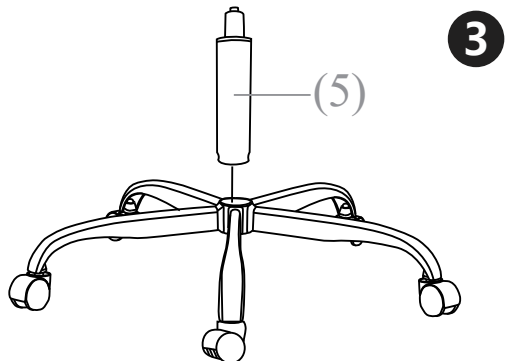

4

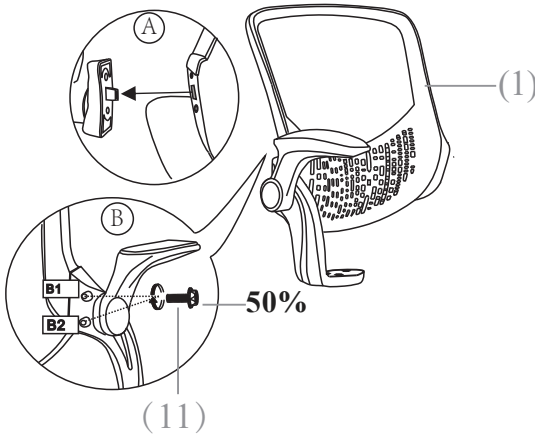

• Step 4:

Attach the Armrest (3)*1(R) to the Backrest (1). Pay attention to the Backrest slot. Use the Wrench(13) to fix bolt(11)*2 into the position B1 and B2.

All bolts do not need to be tightened, they only need to be fixed in half.

5

• Step 5:

Attach the Armrest (3)*1(L) to the Backrest (1). Pay attention to the Backrest slot. Use the Wrench(13) to fix bolt (11)*2 into the position B1 and B2.

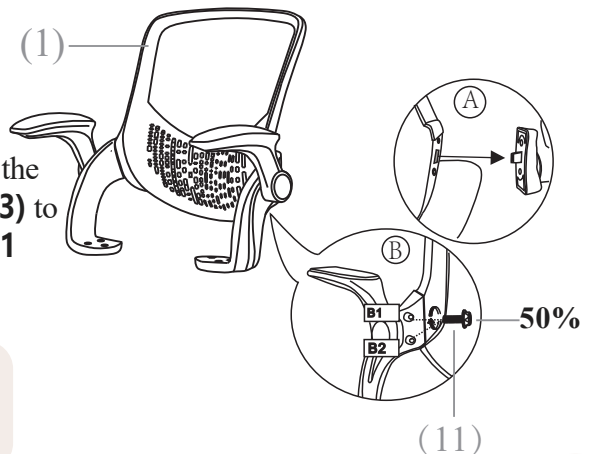

All bolts do not need to be tightened, they only need to be fixed in half.

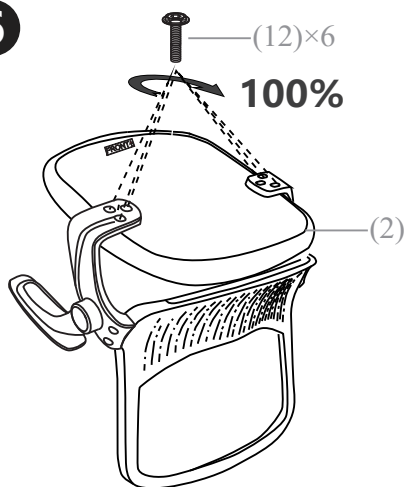
6

• Step 6:

Turn the Seat Cushion **(2)** upside down and align the hole position of the Armrest **(3)*1(L)*1(R)** with the pre-drilled hole position under the Seat Cushion. Attach the Armrest **(3)*1(L)*1(R)** to the Seat Cushion **(2)** with Six Bolts **(12)**. Using the Wrench **(13)**, 100% tighten the Bolts.

Note 1: The "Front" mark on the Armrests and the "Front" mark on the Seat Cushion should be in the same direction.

Note 2: Armrests are labeled with an "L" (left) or "R" (right) to show which side they should be placed on.

• Step 7:

Attach the Mechanism **(4)** to the Seat Cushion using Two Bolts **(10)** at the front and Two Bolts **(10)** at the back, tighten all the bolts with the Wrench **(13)**.

(Note! Don't make the direction wrong, make sure the front of the Mechanism **(4)** is facing the front of the Seat.)

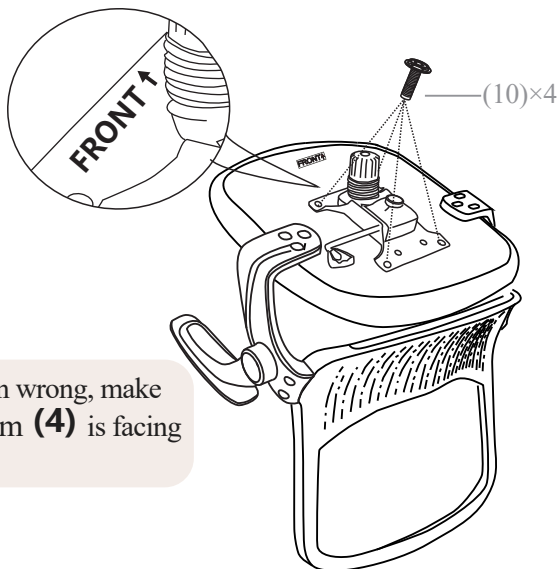
**7**

8

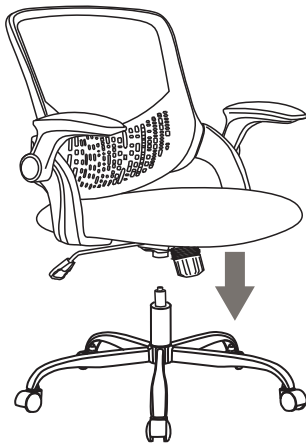

• **Step 8:**

Insert the slot on the back of the mechanism behind the cushion into the Gas Lift.

• **Step 9:**

100% tighten the Backrest Armrest Bolts

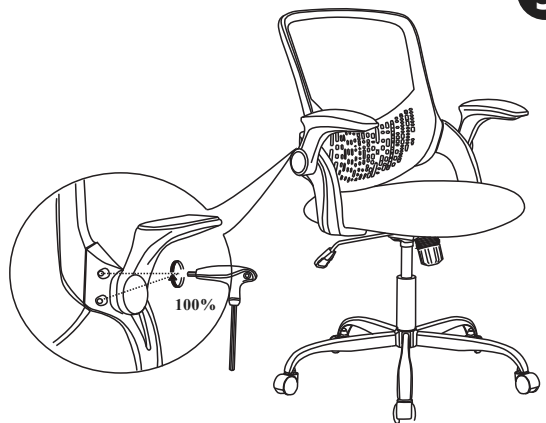

9

CAUTION:

Make sure all bolts and screws are fully tightened before using chair. Lubricate all moving parts and tighten all bolts/screws every 6 month or whenever needed.

Instructions For Use

1. Seat Height: Paddle-shaped lever on the right side

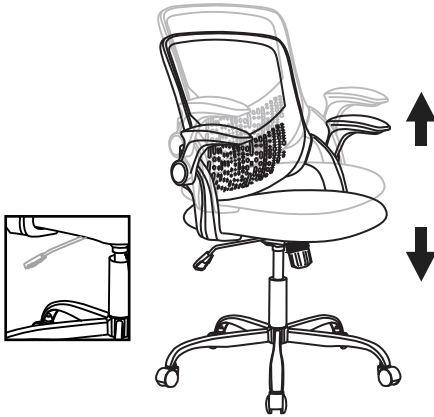

To raise:

While taking your weight off chair, lift lever up.

To lower:

While seated, lift lever up.

* At the proper height, your feet should rest flat on the floor.

2. Padded Flip-up Arms

The padded feature allows you to rest comfortably.

The armrests of the office chair have a flip up design, you could customize them according to your needs.

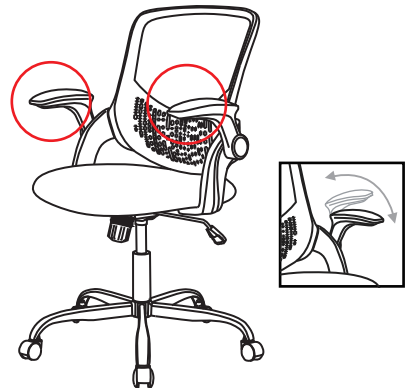

3. Operating the rocking function



To let your chair tilt back, pull the control handle out.

To stop your chair from tilting, sit forward, then push the control handle in.



To increase tension:

While seated, turn knob forward (Counter clockwise).



To decrease tension:

While seated, turn knob backward (Clockwise).

