

ASSEMBLY

After completing each step, repeat the step for the opposite side of the hammock stand.

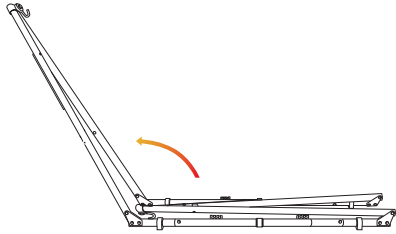

Step 1

Put the base stand horizontally on your chosen surface. Extend the main diagonal bar.

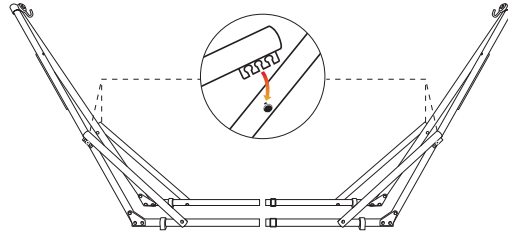

Step 2

Attach the short diagonal bar to the chosen notch on the main diagonal bar.

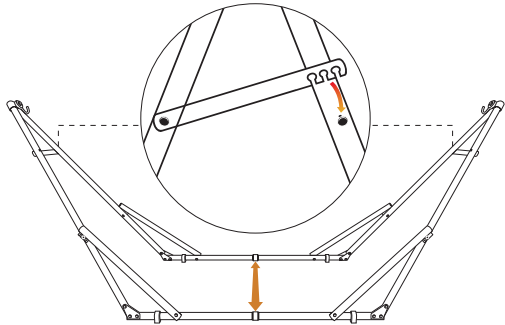

Step 3

Expand the hammock base stand vertically. Connect the cross bar to the notch on the opposite main bar.

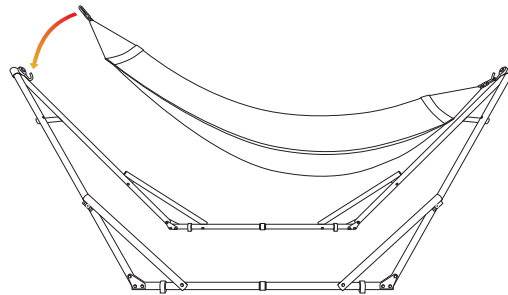

Step 4

Mount the hammock to the S-hooks.

Note: One end feature 2 notches and the other features 3 notches. All short diagonal bars on the same end must have identical notches settings for maximum even weight distribution.

You can choose different notches for opposite sides of the hammock stand while assembling. However, make sure that the two short diagonal bars on each end must be attached to the same notch.

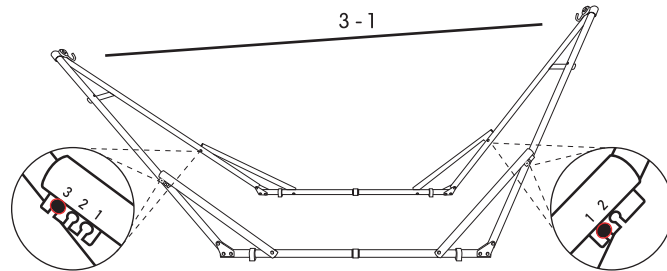

ADJUSTING YOUR HAMMOCK BASE STAND

Tranquillo Hammock Base Stand has 03 standard notches to adjust to your suitable height. To safely adjust the stand, consider adjusting:

- **The cross bars:** the cross bars can be attached to one of the three notches in the main diagonal bars. Choose the first notch for narrowest/highest setting, middle for medium, and last notch for widest/lowest setting.

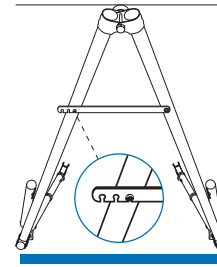

1

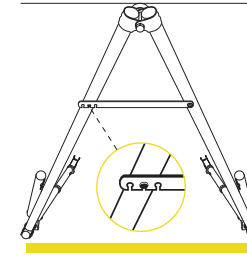

2

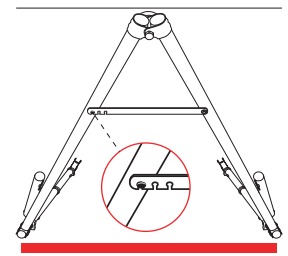

3

The short diagonal bars: the short diagonal bars can be attached to one of the notches in the main diagonal bars. Choose the first notch for the low setting and the second for the medium setting.

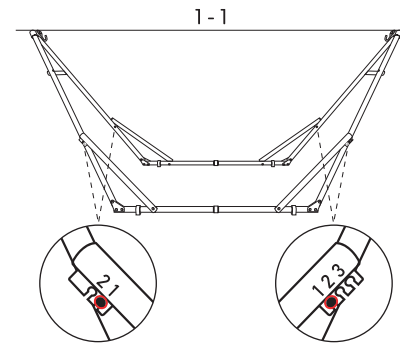

1-1

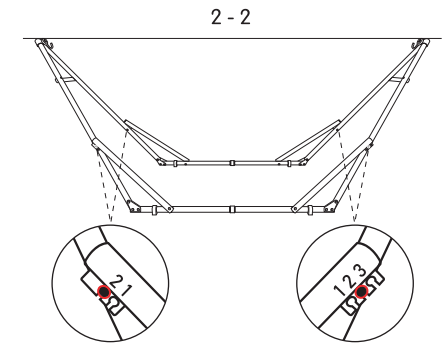

2-2

HANGING YOUR HAMMOCK

- **The jump ring attached to the hammock.**

HIGH

Hang your hammock using the first jump ring. Suitable for taller persons, or in want of more elevated hammock.

STANDARD

Hang your hammock using the second jump ring. Suitable for most heights.

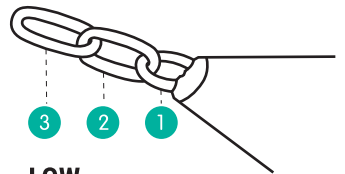

3

2

1

LOW

Hang your hammock using the third jump ring. Suitable for shorter persons or for easier rocking movements.