

WGen7500DF

Dual Fuel Portable Generator

Gasoline: 7500 Running Watts | 9500 Peak Watts

Propane: 6750 Running Watts | 8550 Peak Watts

DO NOT RETURN THIS PRODUCT TO THE STORE

If you have questions or need assistance, please call customer service at 855-944-3571.

INTRODUCTION

TABLE OF CONTENTS

INTRODUCTION

DISCLAIMERS.....	2
ALL RIGHTS RESERVED.....	2
SPECIFICATIONS.....	3

SAFETY

SAFETY DEFINITIONS.....	4
SAFETY SYMBOLS.....	4
SAFETY INSTRUCTIONS.....	5
SAFETY LABELS AND DECALS.....	8
CONTROL PANEL COMPONENTS.....	10
GENERATOR COMPONENTS.....	11

ASSEMBLY

CARTON CONTENTS.....	12
INSTALL FEET AND WHEELS.....	12
INITIAL OIL FILL.....	13
FUEL.....	13
CONNECT A LPG/PROPANE TANK.....	14
CONNECT THE BATTERY.....	15

OPERATION

GENERATOR LOCATION.....	16
GROUNDING.....	16
HIGH ALTITUDE OPERATION.....	17
REMOTE START.....	17
FUEL SELECTOR SWITCH.....	18
BREAK-IN PERIOD.....	18
BEFORE STARTING THE GENERATOR.....	18
STARTING THE ENGINE: GASOLINE.....	18
STARTING THE ENGINE: PROPANE.....	19
SWITCHING FUEL SOURCES.....	19
STOPPING THE ENGINE.....	19
FREQUENCY OF USE.....	19

AC CIRCUIT BREAKERS.....	20
GENERATOR CAPACITY.....	20
POWER MANAGEMENT.....	20
EXTENSION CORDS.....	21
ST SWITCH.....	21
TRANSPORTING.....	22

MAINTENANCE

MAINTENANCE SCHEDULE.....	23
MAINTENANCE REMINDERS.....	23
MAINTENANCE REPLACEMENT PARTS.....	23
AIR FILTER MAINTENANCE.....	23
ENGINE OIL LEVEL CHECK.....	24
ENGINE OIL CHANGE.....	25
SPARK PLUG MAINTENANCE.....	25
SPARK ARRESTOR SERVICE.....	26
FUEL FILTER.....	26
BATTERY MAINTENANCE.....	26
BATTERY REPLACEMENT.....	26
STORAGE.....	27
VALVE CLEARANCE.....	28

TROUBLESHOOTING

TROUBLESHOOTING.....	29
----------------------	----

EXPLODED VIEWS

EXPLODED VIEWS.....	31
---------------------	----

SCHEMATICS

SCHEMATICS.....	37
-----------------	----

⚠ WARNING: Operating, servicing, and maintaining this equipment can expose you to chemicals including engine exhaust, carbon monoxide, phthalates, and lead, which are known to the State of California to cause cancer and birth defects or other reproductive harm. To minimize exposure, avoid breathing exhaust, and wear gloves or wash your hands frequently when servicing this equipment. For more information go to www.P65warnings.ca.gov.

DISCLAIMERS

All information, illustrations, and specifications in this manual were in effect at the time of publishing. The illustrations used in this manual are intended as representative reference views only. We reserve the right to make any specification or design change without notice.

ALL RIGHTS RESERVED

All rights reserved. No reproduction allowed in any form without written permission from Westinghouse Outdoor Power Equipment, LLC.

⚠ DANGER	
	Read this manual before using or performing maintenance on this product. Failure to follow the instructions and safety precautions in this manual can result in serious injury or death.

SAVE THESE INSTRUCTIONS

INTRODUCTION

SPECIFICATIONS

Specifications	
Running Watts:	7500 Gas / 6750 LPG
Peak Watts:	9500 Gas / 8550 LPG
Rated Voltage:	120/240V
Rated frequency:	60 Hz @ 3600 RPM
Phase:	Single phase
Total Harmonic Distortion:	≤ 23%
Engine Displacement:	420 cc
Starting Type:	Recoil, Electric Start, Remote
Fuel Capacity:	6.6 Gallons (25 Liters)
Fuel Type:	87–93 octane*
Oil Capacity:	1.16 Quart (1.1 Liter)
Oil Type:	SAE 10W-30
Spark Plug:	F7TC
Spark Plug Gap:	0.024 – 0.032 in. (0.60 – 0.80 mm)
Valve Intake Clearance:	0.0031 – 0.0047 in. (0.08 – 0.12 mm)
Valve Exhaust Clearance:	0.0051 – 0.0067 in. (0.13 – 0.17 mm)
AC Grounding System:	Neutral bonded to frame
Voltage Regulator:	AVR
Alternator Type:	Brushed
Maximum Ambient Temperature:	104°F (40°C)
Certifications:	<ul style="list-style-type: none">• EPA• CARB• CSA

*Ethanol content of 10% or less. DO NOT use E15 or E85.

UPDATES

The latest User Manual for your Westinghouse generator can be found under our support tab. <https://westinghouseoutdoorpower.com/pages/manuals>

Or scan the following QR code with your smartphone camera to be directed to the link.



NOTICE

This product is designed and rated for continuous operation at ambient temperatures up to 104°F (40°C). If needed, this product can be operated at temperatures ranging from 5°F (15°C)–122°F (50°C) for short periods. If the product is exposed to temperatures outside of this range during storage, it should be brought back within this range before operation. This product must always be operated outdoors in a well-ventilated area and far away from doors, windows, and other vents.

Maximum wattage and current are subject to and limited by such factors as fuel BTU content, ambient temperature, altitude, engine conditions, etc. Maximum power decreases about 3.5% for each 1,000 feet above sea level, and will also decrease about 1% for each 10°F (6°C) above 60°F (16°C) ambient temperature.

PRODUCT REGISTRATION

For trouble-free warranty coverage, it is important to register your Westinghouse generator.

You can register by:

- Completing and mailing the product registration card included in the carton.
- Registering your product online at: <https://westinghouseoutdoorpower.com/pages/warranty-registration>
- Scan the following QR code with your smartphone camera to be directed to the mobile registration link.



- Sending the following product information to:

Westinghouse Outdoor Power
Warranty registration
777 Manor Park Drive
Columbus, OH 43228

For Your Records

Date of Purchase: _____

Model Number: _____

Serial Number: _____

Place of Purchase: _____

IMPORTANT: Keep your purchase receipt for trouble-free warranty coverage.

SAFETY

SAFETY DEFINITIONS

The words DANGER, WARNING, CAUTION, and NOTICE are used throughout this manual to highlight important information. Make sure that the meanings of this safety information is known to all who operate, perform maintenance on, or are near the generator.



This safety alert symbol appears with most safety statements. It means attention, become alert, your safety is involved! Please read and abide by the message that follows the safety alerts symbol.

⚠ DANGER

Indicates a hazardous situation which, if not avoided, will result in death or serious injury.

⚠ WARNING

Indicates a hazardous situation which, if not avoided, could result in death or serious injury.

⚠ CAUTION

Indicates a hazardous situation which, if not avoided, could result in minor or moderate injury.

NOTICE

Indicates a situation which can cause damage to the generator, personal property, and/or the environment, or cause the equipment to operate improperly.

Note: Indicates a procedure, practice or condition that should be followed for the generator to function in the manner intended.

SAFETY SYMBOLS

Follow all safety information contained in this manual and on the generator.

Symbol	Description
	Safety Alert Symbol
	Electrocution Hazard
	Asphyxiation Hazard
	Burn Hazard. Do not touch hot surfaces.
	Electrical Shock Hazard
	Fire Hazard
	Maintain Safe Distance
	Lifting Hazard
	Read Manufacturer's Instructions
	Do Not Operate in Wet Conditions

⚠ DANGER

Using a generator indoors CAN KILL YOU IN MINUTES. Generator exhaust contains carbon monoxide. This is a poison you cannot see or smell.



NEVER use inside a home or garage, EVEN IF doors and windows are open.



Only use OUTSIDE and far away from windows, doors, and vents.

SAFETY INSTRUCTIONS

CORRECT USAGE

Example location to reduce risk of carbon monoxide poisoning
ONLY use outside and downwind, far away from windows, doors and vents. Direct exhaust away from occupied spaces

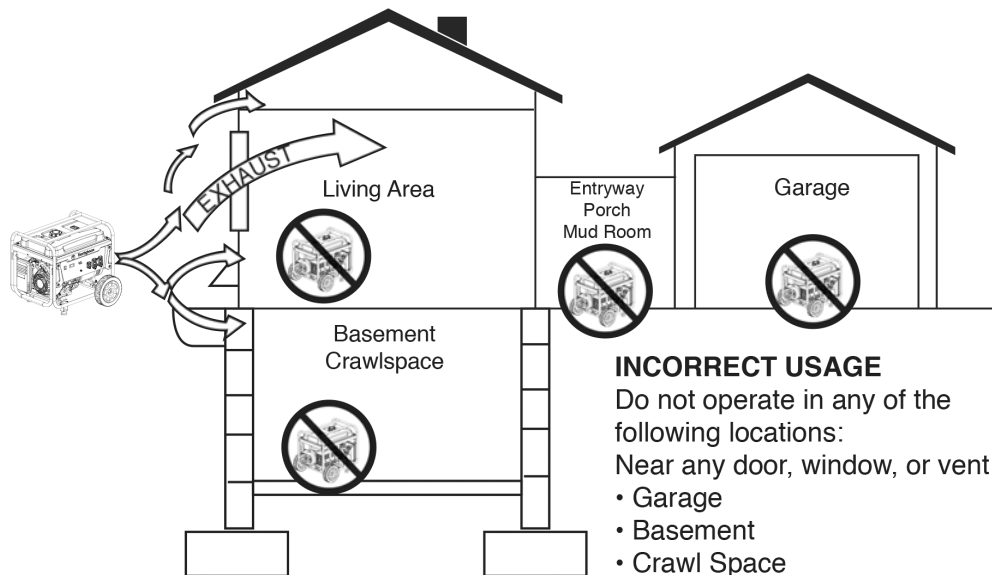
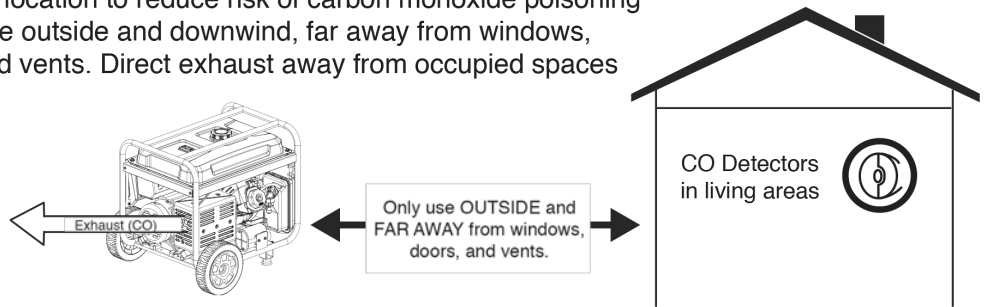

INCORRECT USAGE

Do not operate in any of the following locations:

Near any door, window, or vent

- Garage
- Basement
- Crawl Space
- Living Area
- Attic
- Entry Way
- Porch
- Mudroom

NOTICE

Install battery-powered carbon monoxide detectors or plug-in carbon monoxide detectors with battery back-up in living areas.

⚠ DANGER

Fire and electrocution hazard. Do not connect to a building's electrical system unless the generator and transfer switch have been properly installed and the electrical output has been verified by a qualified electrician. The connection must isolate the generator power from utility power and must comply with all applicable laws and electrical codes.

⚠ DANGER

Electrocution hazard. Never use the generator in a location that is wet or damp. Never expose the generator to rain, snow, water spray, or standing water while in use. Protect the generator from all hazardous weather conditions. Moisture or ice can cause a short circuit or other malfunction in the electrical circuit.

SAFETY

GENERAL SAFETY PRECAUTIONS

- Never use the generator to power medical support equipment.
- Do not operate the generator when you are tired or under the influence of drugs, alcohol, or medication.
- Do not use generator with electrical cords which are worn, frayed, bare, or otherwise damaged.
- All electrical tools and appliances operated from this generator must be properly grounded by use of a third wire or be double-insulated.
- When this generator is used to supply a building wiring system the generator must be installed by a qualified electrician and connected to a transfer switch as a separately derived system in accordance with NFPA 70, National Electrical Code.
- If you begin to feel sick, dizzy, or weak while using the generator, move to fresh air IMMEDIATELY. See a doctor, as you can have carbon monoxide poisoning.
- Only use OUTSIDE and far away from windows, doors, and vents as recommended by the US Department of Health and Human Services Centers for Disease Control and Prevention. Your specific home and/or wind conditions may require additional distance.
- While operating and storing, keep at least five feet of clearance on all sides of the generator, including overhead. Allow the generator to cool a minimum of 30 minutes before storage. Heat created by the muffler and exhaust gases could be hot enough to cause serious burns and/or ignite combustible objects.
- Do not touch the muffler or engine. They are very HOT and will cause severe burns. Do not put body parts or any flammable or combustible materials in the direct path of the exhaust.
- Always remove any tools or other service equipment used during maintenance away from the generator before operating.
- Avoid skin contact with engine oil or gasoline. Wear protective clothing and equipment. Wash all exposed skin with soap and water.

FUEL SAFETY

- Store fuel in a container approved for gasoline.
- Do not smoke when filling the generator with gasoline.
- Do not allow the generator's gas tank to overflow when filling.
- Shut down the engine and allow it to cool for two minutes before adding gasoline or oil to the generator.
- Never remove the fuel cap when the generator is running. Shut off the engine and allow the unit to cool at least two minutes. Remove the fuel cap slowly to release pressure, keep fuel from escaping around the cap, and to avoid the heat from the muffler igniting fuel vapors. Tighten the fuel cap securely after refueling.
- Wipe spilled fuel from the unit.
- Never attempt to burn off spilled fuel.
- Never overfill the fuel tank. Leave room for fuel to expand. Overfilling the fuel tank can result in a sudden overflow of gasoline and result in spilled gasoline coming in contact with HOT surfaces.
- Spilled fuel can ignite. If fuel is spilled on the generator, wipe up any spills immediately. Dispose of rag properly. Allow area of spilled fuel to dry before operating the generator.
- Wear eye protection while refueling.
- Never use gasoline as a cleaning agent.
- Store any containers containing gasoline or LPG/propane in a well-ventilated area, away from any combustibles or source of ignition.

GASOLINE AND GASOLINE VAPOR (GAS)

⚠ DANGER

Fire and explosion hazard. Gasoline and LPG/propane are highly explosive and flammable and can cause severe burns or death.

- In case of a gas fire, do not attempt to extinguish the flame if the fuel tank valve is in the ON position. Introducing an extinguisher to a generator with an open fuel valve could create an explosion hazard.
- Gas has a distinctive odor, this will help detect potential leaks quickly.
- Gas vapors can cause a fire if ignited.
- Gasoline is a skin irritant and needs to be cleaned up immediately if it comes in contact with the skin.

LIQUID PETROLEUM GAS (LPG/PROPANE)

⚠ WARNING

Fire and explosion hazard. Never use a gas container, LPG/propane connector hose, LPG/propane tank or any other fuel item that appears to be damaged.

⚠ CAUTION

Fire and explosion hazard. Only use approved LPG/propane tanks with an Overfilling Prevention Device (OPD) valve. Always keep the tank in a vertical position with the valve on top and placed at ground level on a flat surface. Do not allow tanks to be near any heat source. When transporting and storing, turn the propane tank valve to the fully closed position and disconnect the tank. Make sure to always cover the generator inlet and tank outlet with protective plastic caps.

- LPG/Propane is highly flammable and explosive.
- Flammable gas under pressure can cause a fire or explosion if ignited.
- LPG/Propane can settle in low places because it is heavier than air.
- LPG/Propane has a distinctive odor added to help detect potential leaks.
- Always keep a LPG/Propane tank in an upright position.
- When exchanging LPG/propane tanks, be sure the tank valve is the same type.
- In case of a LPG/propane fire, do not attempt to extinguish unless the fuel supply can be shut off safely.
- LPG/propane will burn the skin. Prevent skin contact at all times.
- Keep the propane tank away from the generator exhaust.
- Large (500–1000 gallon) LPG/propane tanks will require a certified plumber to install the fuel line to the generator and the loose regulator is not used (the regulator that is attached to the fuel tank). The pressure as measured at the regulator mounted to the generator must be 7" to 14" of water column. A certified plumber must ensure that the pressure is correct or install a step down regulator if needed.

⚠ WARNING

Fire and explosion hazard. If there is a strong smell of propane while operating the generator, fully close the LPG/propane tank valve immediately. Once the propane is off, use soapy water to check for leaks on the hose and connections on the tank valve and the generator. Do not smoke or light a cigarette or check for leaks using any open flame source such as a match or lighter. If a leak is found, contact a qualified technician to inspect and repair the LPG/propane system before using the generator.

When starting the generator:

- Make sure that the fuel cap, air filter, spark plug, fuel lines, and exhaust system are properly in place.
- If you spill any gasoline on the tank, allow it to fully evaporate before operating.
- Make sure the generator and LPG/propane tank are on a flat surface before operating.
- If there is a propane odor do not start the unit because there may be a potential leak. Never place a LPG/propane tank near the engine exhaust.

When transporting or servicing the generator:

- Make sure the LPG/propane tank and LPG/propane hose are not attached to the generator.
- Disconnect the spark boot to prevent accidental starting.

When storing the generator:

- Store away from sparks, open flames, pilot lights, heat, and other sources of ignition.
- Do not store gas or a LPG/propane tank near furnaces, water heaters, or any other appliances that produce heat or have automatic ignitions.

SAFETY

SAFETY LABELS AND DECALS

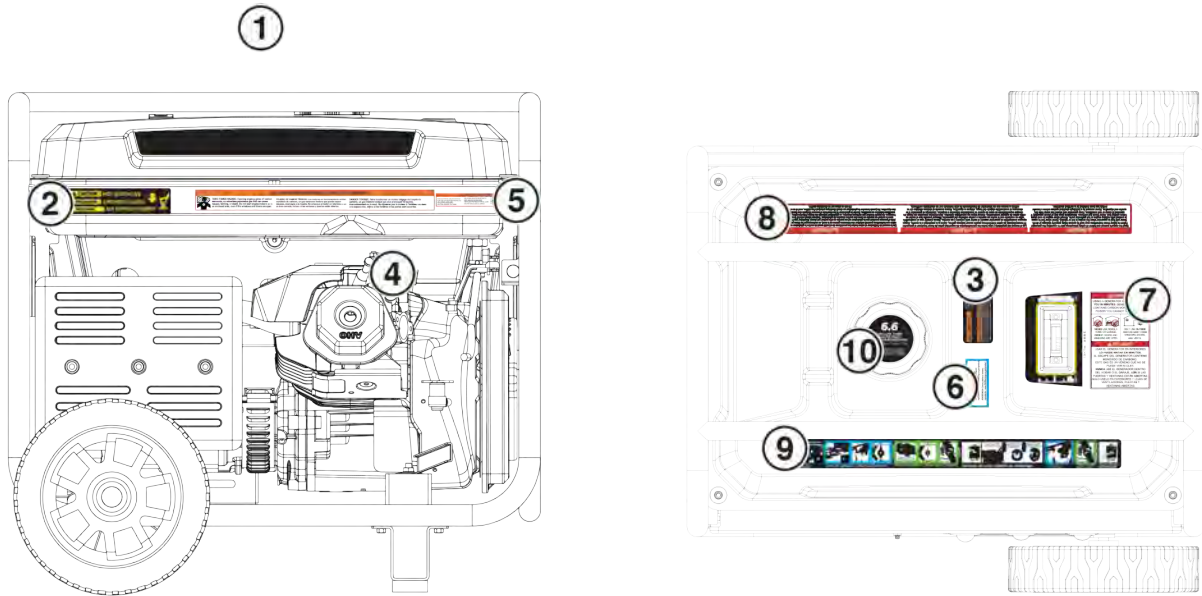

1 **⚠ WARNING/ADVERTENCIA /AVERTISSEMENT**

TOXIC FUMES HAZARD. Running engines gives off carbon monoxide, an odourless poisonous gas that can cause nausea, fainting, or death. Do not start engine indoors or in an enclosed area, even if the windows and doors are open.

PELIGRO DE HUMOS TÓXICOS. Los motores en funcionamiento emiten monóxido de carbono, un gas venenoso inodoro que puede causar náuseas, desmayos o la muerte. No arranque el motor en interiores o en un área cerrada, incluso si las ventanas y puertas están abiertas.

DANGER TOXIQUE. Faire fonctionner un moteur dégage de l'oxyde de carbone, un gaz inodore toxique qui peut provoquer la nausée, évanouissement ou la mort. Ne démarrer pas le moteur à l'intérieur ou dans une espace clos, même si les fenêtres et les portes sont ouvertes.

2 **⚠ CAUTION HOT SURFACES**
⚠ PRECAUCIÓN SUPERFICIES CALIENTES
⚠ ATTENTION AUX SURFACES CHAUDES

5 **⚠ WARNING/ADVERTENCIA /AVERTISSEMENT**

ELECTRICAL EQUIPMENT ONLY FOR USE IN A WEATHER PROTECTED WELL VENTILATED AREA. NEUTRAL BONDED TO FRAME.

SÓLO PARA EQUIPOS ELÉCTRICOS PARA USO EN UN ÁREA BIEN VENTILADA PROTEGIDA POR EL CLIMA. NEUTRO VINCULADO AL MARCO.

POUR MATÉRIEL ÉLECTRIQUE SEULEMENT POUR UTILISATION DANS UN ENDROIT BIEN VENTILÉ ET PROTÉGÉ CONTRE LES INTÉMPÉRIES NEUTRE RELIÉ AU D'ADMISS

3 **⚠ WARNING** NEVER FUEL UNIT WITH ENGINE RUNNING. ALWAYS FUEL IN WELL VENTILATED AREA. ALWAYS CLEAN FUEL SPILLS. NEVER ALLOW UNIT TO COOL BEFORE FUELING.

⚠ ADVERTENCIA NUNCA COMBUSTE LA UNIDAD CON EL MOTOR EN MARCHA. SIEMPRE LÍBRALO DE COMBUSTIBLE EN ZONA BIEN VENTILADA. SIEMPRE LIMPIE LOS DERRAMES DE COMBUSTIBLE. SIEMPRE PERMITA QUE LA UNIDAD ESTE EN FRÍO ANTES DE COMBUSTIBLE.

⚠ AVERTISSEMENT NE FAITES JAMAIS LE PLEIN LORSQUE LE MOTEUR EST EN MARCHÉ. FAITES TOUJOURS LE PLEIN DE LUNITE DANS UN ENDROIT BIEN VENTILÉ. NETTOYEZ TOUJOURS LE CARBURANT DÉVERSÉ. LAISSEZ TOUJOURS REFRIGÉRER L'APPAREIL AVANT DE FAIRE LE PLEIN.

4 **Normal Operation of Auto Choke**

CHOKES OFF ON

6 **⚠ WARNING: Cancer and reproductive harm -** www.P65Warnings.ca.gov/product
⚠ AVERTISSEMENT: Cancer et problèmes de reproduction - www.P65Warnings.ca.gov/product
⚠ ADVERTENCIA: Cáncer y daños al sistema reproductor - www.P65Warnings.ca.gov/product

7 **⚠ DANGER**

USING A GENERATOR INDOORS CAN KILL YOU IN MINUTES. GENERATOR EXHAUST CONTAINS CARBON MONOXIDE. THIS IS A POISON YOU CANNOT SEE OR SMELL.

NEVER USE OUTSIDE HOME OR GARAGE. EVEN IF DOORS AND WINDOWS ARE OPEN.

ONLY USE OUTSIDE AND FAR AWAY FROM WINDOWS, DOORS, AND VENTS.

⚠ DANGER Utiliser un générateur à l'intérieur PEUT VOUS TUER EN QUELQUES MINUTES. Les gaz d'échappement du générateur contiennent du monoxyde de carbone. C'est un gaz toxique invisible et inodore.

⚠ PELIGRO Si usa un generador en interiores MORIRÁ EN POCOS MINUTOS. El escape del generador contiene monóxido de carbono. Es un veneno que no tiene olor ni se puede ver.

NE JAMAIS utiliser à l'intérieur d'une maison ou d'un garage. MÊME SI les portes et les fenêtres sont ouvertes.

NE JAMAIS à la use dentro de una casa o garage. AUN SI las puertas y ventanas están abiertas.

UTILISER UNIQUEMENT à l'EXTÉRIEUR et loin des fenêtres, portes et ventilations.

SÓLO USAR EN EXTERIORES y lejos de ventanas, puertas y ductos de ventilación.

8 **⚠ DANGER** Read the owner's manual and follow all safety procedures prior to operating the generator. Failure to follow these instructions may lead to serious injury, property damage or death. Never add fuel to generator when the engine is hot or running. Never allow fuel to come in contact with running engine or hot generator parts. Always allow engine to cool down before adding fuel. Never touch hot surfaces. Generators pose risk of shock especially if operated in damp or wet conditions. Keep generator and stored fuel away from fire, sparks and cigarettes. Never connect to a building's electrical system unless a transfer switch has been installed by a certified electrician.

⚠ PELIGRO Lea el manual del propietario y siga todas las procedimientos de seguridad antes de hacer funcionar el generador. El incumplimiento de estas instrucciones puede causar lesiones graves, daños a la propiedad o la muerte. Nunca agregue combustible al generador cuando el motor está caliente o en marcha. Nunca permita que el combustible entre en contacto con el motor en marcha o partes calientes del generador. Siempre permita que el motor se enfríe antes de agregar combustible. Nunca toque las superficies calientes. Mantenga el generador y los almacenos el combustible alejado del fuego, chispas o cigarrillos. Nunca conecte al sistema eléctrico de un edificio a menos que un interruptor de transferencia ha sido instalado por un electricista certificado.

⚠ DANGER Lire le manuel de l'utilisateur et suivre toutes les procédures de sécurité avant de mettre le générateur en marche. Le fait de ne pas suivre ces instructions journalier entraîner des blessures graves ou la mort, ou endommager les biens personnels. Ne jamais faire le plein d'essence pendant que le générateur est en marche ou si le moteur est chaud. Éviter que l'essence n'entre en contact avec le moteur en marche ou avec des parties chaudes du générateur. Toujours laisser refroidir le moteur avant d'ajouter de l'essence. Ne jamais toucher aux surfaces chaudes. Le générateur présente un risque d'électrochoc, particulièrement dans des conditions humides ou mouillées. Garder le générateur et les réservoirs d'essence éloignés des flammes nues, des étincelles et des cigarettes. Ne jamais brancher le générateur au circuit électrique principal d'un bâtiment, sauf si un commutateur de transfert a été mis en place par un électricien qualifié.

9 **Start Instructions**

Inicio de gasolina | Début de l'essence **Inicio de propano | Démarrage au propane** **Opciones de inicio | Options de démarrage**

MANUAL START **ELECTRIC START** **BATTERY START**

START **STOP** **BATTERY STOP**

DO NOT OVERFILL

10 6.6 Gal 25L

USE FUEL STABILIZER FOR STORAGE

UTILISEZ UN STABILISATEUR DE CARBURANT POUR LE STOCKAGE

EL USO DEL ESTABILIZADOR DE COMBUSTIBLE PARA EL ALMACENAMIENTO

87 MINIMUM OCTANE
 87 OCTANO MINIMUM
 87 OCTANO MINIMO

SAFETY LABELS AND DECALS

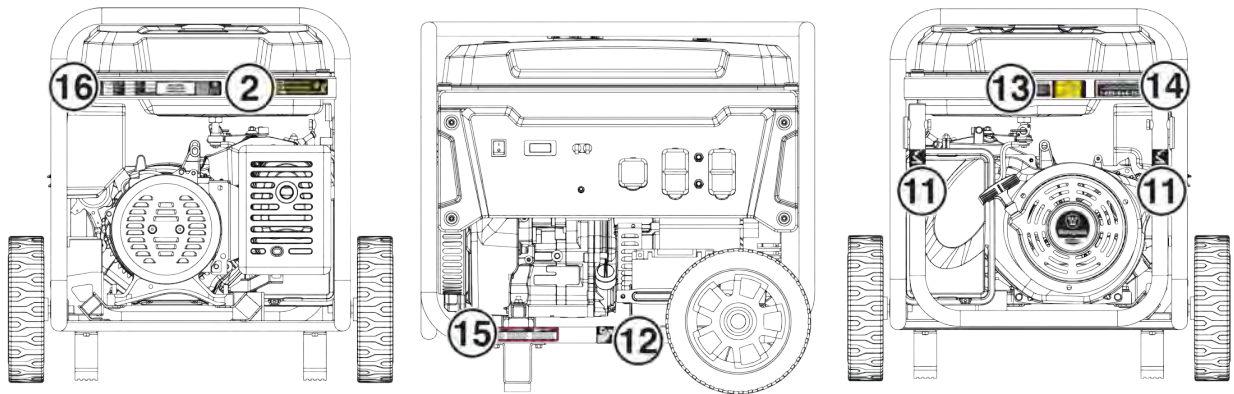

13 **MANTENIEN DU FILTRE À AIR**

Rincer avec un solvant nettoyant et faire sécher toutes les 50 heures (toutes les 10 heures en cas de conditions poussiéreuses), puis immerger dans de l'huile moteur propre jusqu'à saturation. Serrer pour enlever l'excédent d'huile.

FUEL
CARBURANT / COMBUSTIBLE

ARABIA OFF / ON

14 **FOR TECHNICAL ASSISTANCE or SERVICE CALL TOLL FREE**

PARA LA AYUDA TÉCNICA Y SERVICIO LLAMADA
POUR SUPPORT TECHNIQUE ou SERVICE, APPELEZ SANS FRAIS

1-855-944-3571

3 YEAR LIMITED WARRANTY

15 **⚠ DANGER ⚠ PELIGRO ⚠ DANGER**

Read owners manual before operating generator on LPG/propane. LPG/Propane is highly flammable. Leaking LP-gas can cause a fire or explosion if ignited. If you smell propane while you are operating unit, immediately shut off propane valve. Keep propane tank away from exhaust.

Lea el manual del propietario antes de operar el generador con GLP / propano. GLP / propano es altamente inflamable. La fuga de gas LP puede causar un incendio o una explosión si se enciende. Si huele a propano mientras está operando la unidad, apague inmediatamente la válvula de propano. Mantenga el tanque de propano lejos del escape.

Lisez le manuel du propriétaire avant d'utiliser le générateur sur le propane. Le propane est hautement inflammable. Une fuite de gaz peut provoquer un incendie ou une explosion si elle s'allume. Si vous sentez le propane pendant que vous utilisez l'unité, fermez immédiatement la vanne de propane. Gardez le réservoir de propane à l'écart de l'échappement.

16 **Westinghouse**

Model: **WGan7500DF** Power (Peak): Input Code:
 Part No.: Power (Peak): Max Amp Temp:
 AC Voltage: Frequency: Duty Cycle:
 RPM: TRIM: Designed in Columbus, Ohio, USA. / Conçu à Columbus, Ohio, États-Unis.

Serial No. / De Série:

SERIAL NUMBER
NÚMERO DE SERIE
NUMERO DE SERIE

Register your product:

CSA Master Contract Number: 234179
Número de contrato principal de CSA: 234179

Westinghouse Outdoor Power Equipment, LLC
Columbus, Ohio 43228 USA

Westinghouse Outdoor Power Equipment, LLC
Columbus Ohio 43228 Essen-Unité

Made in Vietnam / Fabriqué en Viêt Nam

FEATURES

CONTROL PANEL COMPONENTS

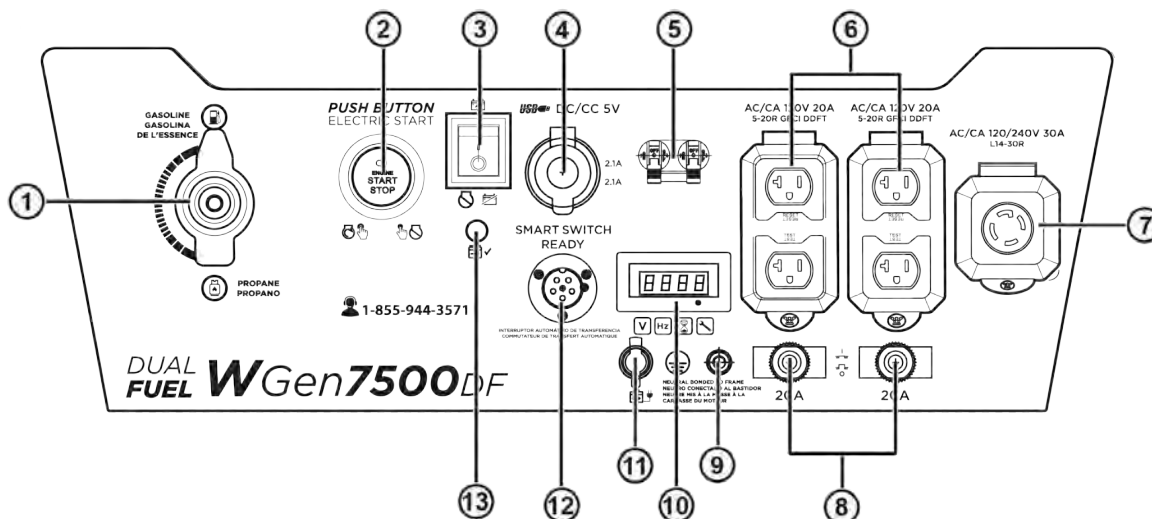

- Fuel Selector Switch:** Used to select gas or propane operation.
- Push-Button START/STOP:** Push once to automatically start the engine. Push again to stop the engine.
- Battery Switch:** Turns battery ON and OFF. Must be ON before electric or remote start.
- USB Ports:** Two-port 5V/2.1A USB outlet. Accepts Type A USB plugs.
- Main Circuit Breaker:** The main circuit breaker controls total output of all outlets to protect the generator from overload or short circuit.
- 120 Volt AC, 20 Amp Duplex GFCI NEMA 5-20R Receptacles:** Receptacles can supply a maximum of 20 Amps.
- 120/240 Volt AC, 30 Amp NEMA 14-30R Twist-Lock Receptacle:** Receptacle can supply a maximum of 30 Amps.
- 20 Amp AC Circuit Breakers:** Circuit breaker limits the current that can be delivered through the NEMA 5-20R receptacles to 20 Amps.
- Ground Terminal:** The ground terminal is used to externally ground the generator.
- Data Center:** Toggle to show voltage, frequency, total hour meter, and run/maintenance timer.
- Battery Charging Port:** Used to charge the battery with the included battery charger.
- Smart Switch Outlet:** Connects the Westinghouse ST Switch (sold separately) to the control panel.
- Battery Indicator:** Indicates that power is ON. Light will remain illuminated while the unit is ON.

DATA DISPLAY



Voltage:
Displays current voltage output.

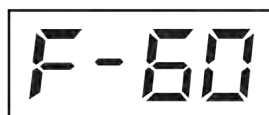

Frequency (Hz):
Displays power output frequency in Hertz.



Lifetime Hours:
Displays the lifetime run hours.



Run Time/Maintenance:
Displays current run time. Resets to zero when shut down. Maintenance reminder displayed when required.



Push the Mode button to cycle through the data display modes.



Mode Button

Maintenance Codes:

P25: Change engine oil
P50: Clean air filter, Change engine oil
P100: Change engine oil, clean air filter, replace fuel filter

FEATURES

GENERATOR COMPONENTS

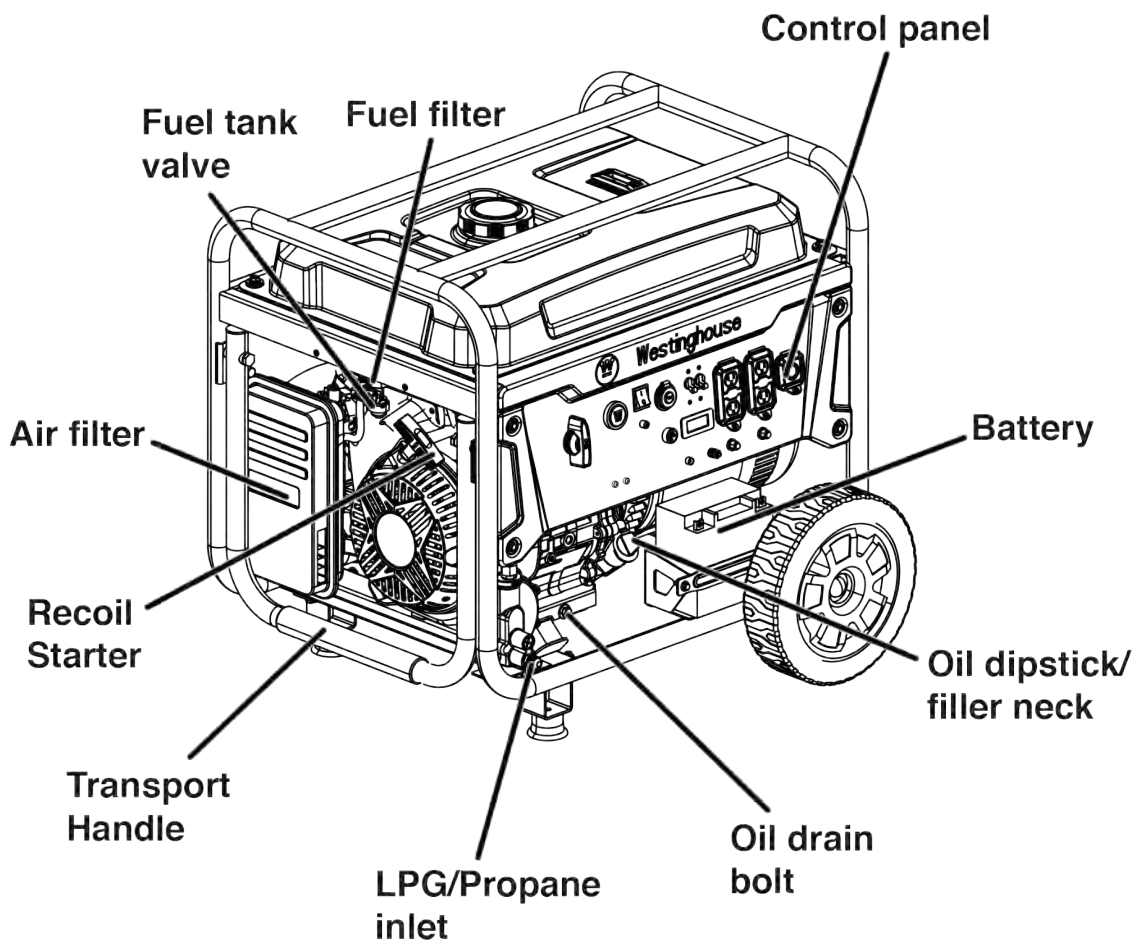
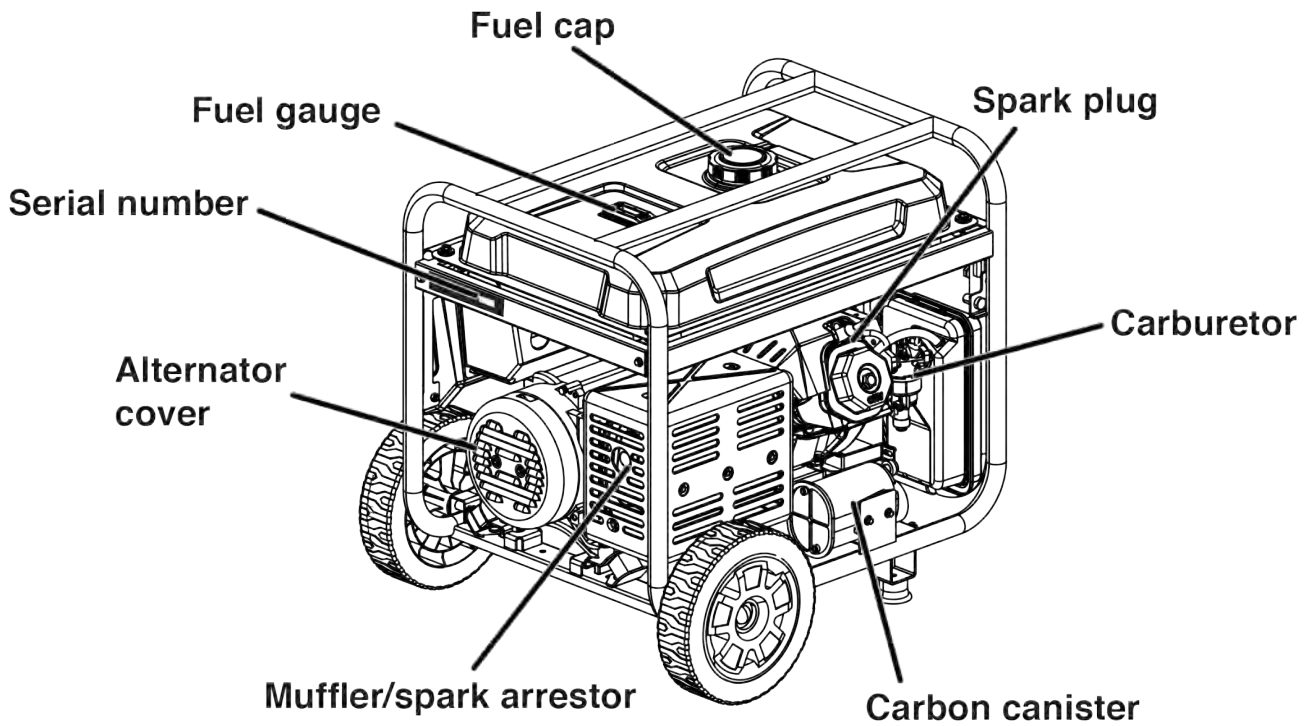

ASSEMBLY

CARTON CONTENTS

⚠ CAUTION

Weight hazard. Always have assistance when lifting the generator.

1. Carefully open the carton.
2. Remove and save the carton contents.
3. Remove and discard the packing tray.
4. Unfold the top of the plastic bag enclosing the generator.
5. Carefully cut the vertical corners of the carton to access the generator.
6. Recycle or dispose of the packaging materials properly.

CARTON CONTENTS

- User manual
- Quick Start Guide
- LPG/propane hose with regulator
- Remote start key fob (attached to recoil starter)
- 1.16 Quart (1.1 Liter) bottle of SAE 10W-30 Oil
- Battery charger
- Spark plug socket wrench
- Oil Funnel
- Assembly wrench
- Wheel and mounting foot components

Item	Quantity
• Mounting foot	2
• Flange bolt, M8	4
• Wheel	2
• Axle pin	2
• Washer	2
• Cotter pin	2

If any parts are missing, contact our service team at service@wpowereq.com or call 1-855-944-3571.

INSTALL FEET AND WHEELS

NOTICE

Assembling the generator will require lifting the unit on one side. Install the mounting feet and wheel before adding fuel or oil.

1. Place generator on a flat surface.
2. Tip the generator on a piece of cardboard or other soft material to protect the frame paint and prevent the generator from sliding.
3. With the included wrench, install the mounting feet to the frame as shown.

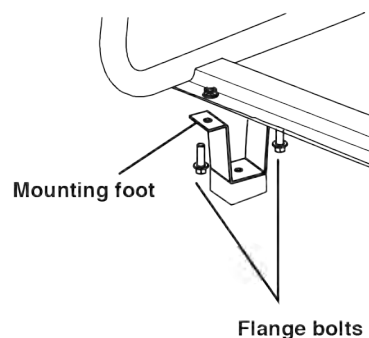

4. Install the wheels as shown.

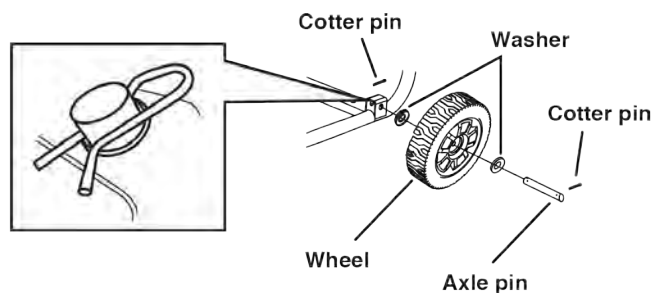

Note: The wheels are only intended for hand transport. The wheels are not suitable for towing the generator either on or off-road.

INITIAL OIL FILL

NOTICE

THIS GENERATOR HAS BEEN SHIPPED WITHOUT OIL. Do not attempt to crank or start engine before it has been properly serviced with recommended oil. Failure to add engine oil before starting will result in serious engine damage.

NOTICE

Use of 2-stroke/cycle oil or other unapproved oil types can cause severe engine damage that is not covered under warranty.

The included, recommended oil type for typical use is 10W-30 engine oil. If running the generator in extreme temperatures, refer to the following chart.

Recommended Engine Oil Type									
			10W-30						
	5W-30					10W-40			
	5W-30 Synthetic								
°F	-20	0	20	40	60	80	100	120	
°C	-28.9	-17.8	-6.7	4.4	15.6	26.7	37.8	48.9	
	Ambient temperature								

1. On a level surface, remove the oil dipstick.

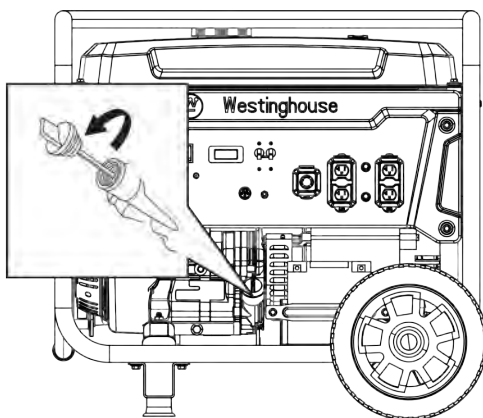

2. Using the supplied funnel and oil, add oil into oil filler neck.

Note: As residual oil from the factory may remain in the engine, add the oil incrementally near the end of the bottle to prevent overfilling the engine. See Engine Oil Level Check in the Maintenance section.

3. Replace the oil dipstick and hand-tighten.

FUEL

⚠ WARNING

Fire and explosion hazard. Never use a gasoline container, gasoline tank, propane connector hose, propane tanks, or any other fuel item that is broken, cut, torn or damaged.

⚠ DANGER

Fire and explosion hazard. Do not overfill fuel tank. Fill only to the red fill ring located in the in-tank fuel screen filter. Overfilling may cause fuel to spill onto engine causing a fire or explosion hazard.

⚠ DANGER

Fire and explosion hazard. Never refuel the generator while the engine is running. Always turn the engine off and allow the generator to cool for two minutes before refueling.

NOTICE



Do not use E15 or E85 fuel in this product. Engine or equipment damage caused by stale fuel or the use of unapproved fuels (such as E15 or E85 ethanol blends) is not covered by warranty. Only use unleaded gasoline containing up to 10% ethanol.

FUEL REQUIREMENTS

- CLEAN, FRESH, unleaded gasoline, 87–93 octane.
- Up to 10% ethanol (gasohol) is acceptable (where available; non-ethanol fuel is recommended).
- DO NOT use E85 or E15.
- DO NOT use a gas oil mix.
- DO NOT modify the engine to run on alternate fuels.
- DO NOT fuel indoors.
- DO NOT create a spark or flame while fueling.

USING FUEL STABILIZER

Adding a fuel stabilizer (not included) extends the usable life of fuel and helps prevent deposits from forming that can clog the fuel system. Follow the manufacturer's instructions for use.

Always mix the correct amount of fuel stabilizer to gasoline in an approved gasoline container before fueling the generator. Run the generator for five minutes to allow the stabilizer to treat the entire fuel system.

ASSEMBLY

FILLING THE FUEL TANK

1. Turn the generator OFF and allow to cool for a minimum of two minutes before fueling.
2. Place the generator on level ground in a well ventilated area.
3. Clean area around fuel cap and remove the cap slowly.

NOTICE

Only fill the tank from an approved gasoline container. Make sure the gasoline container is internally clean and in good condition to prevent fuel system contamination.

4. Slowly add the recommended fuel. Do not overfill. Fill only to the red maximum fill ring on the fuel screen filter visible in the filler neck.

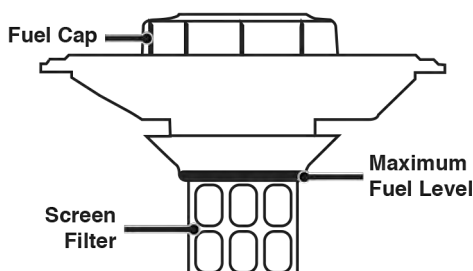

5. Install the fuel cap.

NOTICE

Fuel can damage paint and plastic. Use caution when filling the fuel tank. Damage caused by spilled fuel is not covered under warranty.

NOTICE

Clean the fuel screen filter of debris before and after each fueling. Remove the fuel screen filter by slightly compressing it while removing it from the fuel tank.

CONNECT AN LPG/PROPANE TANK

NOTICE

- The LPG/propane tank can be of any capacity but the tank must conform to the standard as listed in Fuel Safety section.
- Propane tanks that use liquid withdrawal system can not be used on these models.
- Verify the re-qualification date on the tank has not expired.
- Do not use included LPG/propane hose for any other appliances.

NOTICE

- All new tanks must be purged of air and moisture prior to filling. Used tanks that have not been plugged or kept closed must also be purged. The purging process should be done by a propane supplier (Tanks from an exchange supplier should have been purged and filled properly).
- Always position the tank so the connection between the valve and the gas inlet will not cause sharp bends or kinks in the hose.

⚠ WARNING

Explosion hazard. Do not start generator if you smell propane. Always fully close the propane tank valve and disconnect the LPG/propane hose from the generator when not in use.

1. Turn the generator OFF and place on a flat surface in a well ventilated area.
2. Verify that the propane tank valve is in the fully closed position.
3. Remove the cover on the generator propane inlet valve.
4. Use your fingers to hand thread the LPG/propane hose (included) to the propane inlet on the generator.

IMPORTANT: DO NOT use thread seal tape or any other type of sealant to seal the LPG/propane hose connection.

5. Tighten the LPG/propane hose connector to the generator with a 19 mm or adjustable wrench. DO NOT over-tighten.

Torque: 5-10 lb-ft.

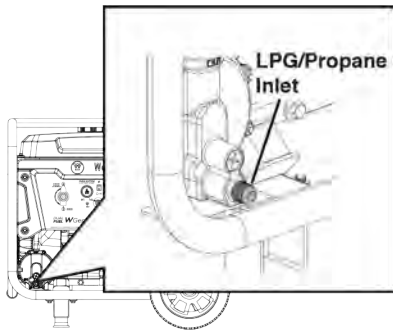

CONNECT THE BATTERY

A quick-connect battery plug is preinstalled on the battery. Remove the cable tie securing the plugs then push firmly to connect them.

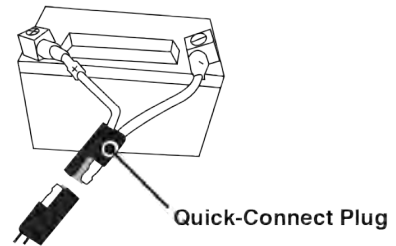

6. Remove the safety plug or cap from the propane tank valve and attach the other end of the hose to the LPG/propane connector on the tank. Hand tighten.
7. Turn the propane tank valve to the fully open position. Check all connections for leaks by wetting the fittings with a solution of soap and water. Bubbles which appear or bubbles which grow indicate that a leak exists. If a leak exists at a fitting, turn the propane tank valve to the fully closed position and tighten the fitting. Open the propane tank valve and recheck the fitting with the soap and water solution. If the leak continues or if the leak is not at a fitting then do not use the generator and contact customer service.



Note: The generator is equipped with a battery charging feature. Once the engine is running, a small charge will slowly recharge the battery.

IMPORTANT: Keep the propane tank valve in the fully closed position unless in use.

OPERATION

GENERATOR LOCATION

Read and understand all safety information before starting the generator.

⚠ DANGER	
Using a generator indoors CAN KILL YOU IN MINUTES . Generator exhaust contains carbon monoxide. This is a poison you cannot see or smell.	
	
NEVER use inside a home or garage, EVEN IF doors and windows are open.	Only use OUTSIDE and far away from windows, doors, and vents.

NEVER operate the generator inside any building, including garages, basements, crawlspaces, sheds, enclosure, or compartment, including the generator compartment of a recreational vehicle.

⚠ DANGER
Electrocution hazard. Never use the generator in a location that is wet or damp. Never expose the generator to rain, snow, water spray, or standing water while in use. Protect the generator from all hazardous weather conditions. Moisture or ice can cause a short circuit or other malfunction in the electrical circuit. Using a generator or electrical appliance in wet conditions, such as rain or snow, or near a pool or sprinkler system, or when your hands are wet, could result in electrocution.

⚠ WARNING
Fire hazard. Only operate the generator on a solid, level surface. Operating the generator on a surface with loose material such as sand or grass clippings can cause debris to be ingested by the generator that could block cooling vents or the air intake system. Allow the generator to cool for 30 minutes before transport or storage.

The generator should be on a flat, level surface at all times (Even while not in operation). The generator must have at least 5 ft. (1.5 m) of clearance from all combustible material.

Do not operate the generator in the back of a SUV, camper, trailer, truck bed (regular, flat, or otherwise), under stairs, next to walls or buildings, or in any other location that will not allow for adequate cooling of the generator and/or the muffler. **DO NOT** contain generators during operation.

⚠ DANGER
Asphyxiation hazard. Place the generator in a well-ventilated area. DO NOT place the generator near vents or intakes where exhaust fumes could be drawn into occupied or confined spaces. Carefully consider wind and air currents when positioning the generator.

GROUNDING

⚠ WARNING
Shock hazard. Failure to properly ground the generator can result in electric shock.

NOTICE
Only use grounded 3-prong extension cords, tools, and appliances, or double-insulated tools and appliances.

The generator neutral is bonded to the frame. There is a permanent conductor between the generator (stator wire) and the frame. If this generator will be used only with cord and plug equipment connected to the receptacles mounted on the generator, National Electric Code does not require that the unit be grounded. However, other methods of using the generator may require grounding to reduce the risk of shock or electrocution.

Before using the ground terminal, consult a qualified electrician, electrical inspector, or local agency having jurisdiction for local codes or ordinances that apply to the intended use of the generator.

DISCONNECTING THE BONDED NEUTRAL

Removing the bonded neutral disables the GFCI protection from the 5-20R receptacles. The bonded neutral should only be removed under specific circumstances. Consult a qualified electrician to determine if your situation requires disconnecting the bonded neutral.

1. Remove the alternator cover.
2. Remove the bonded jumper wire and reinstall the nut.

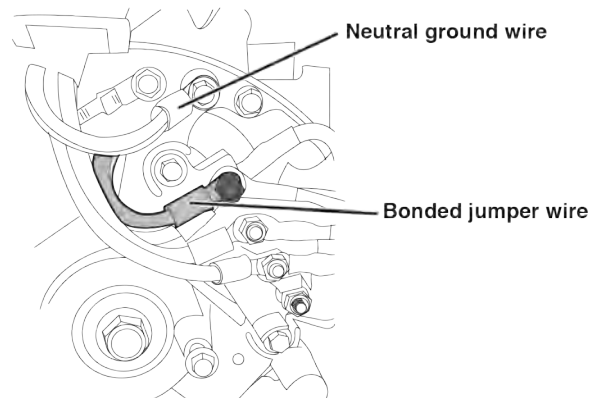

- Remove the nut securing the neutral ground wire and attach the bonded jumper wire. Reinstall the nut.

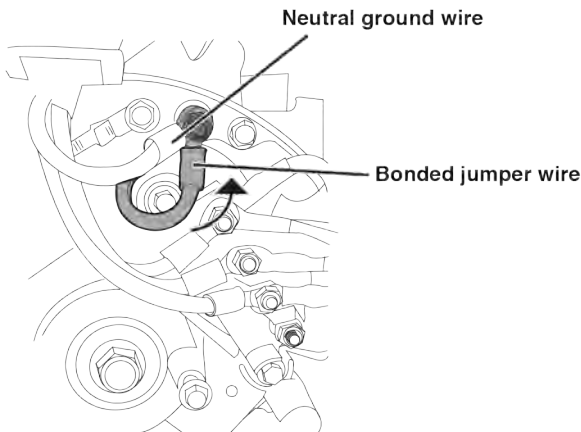

- Reinstall the alternator cover.

IMPORTANT: Apply a new “NEUTRAL UNBONDED” Label over the “NEUTRAL BONDED TO FRAME” label on the front of the control panel.

HIGH ALTITUDE OPERATION

Engine power is reduced the higher you operate above sea level. Output will be reduced approximately 3.5% for every 1000 feet of increased altitude from sea level.

High altitude adjustment is required for operation at altitudes over 5,000 ft. (1524 m). Operation without this adjustment will cause decreased performance, increased fuel consumption, and increased emissions.

NOTICE

Do not operate the generator at altitudes below 2,000 ft. (762 m) with the high altitude kit installed. Engine damage may occur.

High Altitude Carburetor Kit	Part# 518073
High Altitude DF Regulator:	Part# 518045-1

Note: You must purchase both the Dual Fuel Regulator and Carburetor Kit for proper high altitude operation.

REMOTE START

⚠ WARNING

Verify that the area around the generator is clear before remote starting the generator.

The remote start key fob included with the generator should be attached to the recoil handle or control panel. If your unit was shipped without a key fob, contact Westinghouse customer service.

The generator can be started remotely from up to 99 feet (30 meter) using the remote start key fob.

Note: As the batteries in the remote start key fob drain, operational distance will decrease.

PAIRING THE REMOTE START

Remote replacement batteries: (2) CR2016

If the remote start key fob is replaced or needs re-paired to the generator, follow this procedure.

- Turn the generator battery switch to the ON position. The power indicator light will illuminate.

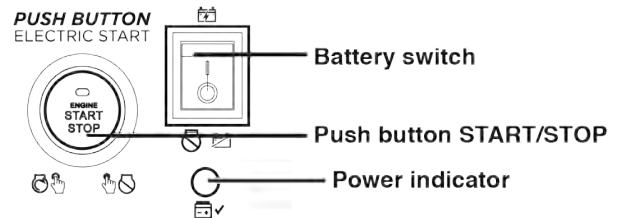

- Push and hold the red Pairing button on the side of the control panel until the START/STOP button illuminates.

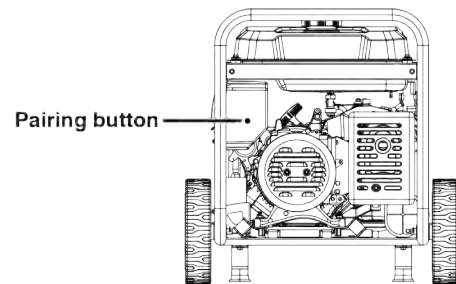

- Push and hold the STOP button on the key fob until the START/STOP button illumination turns OFF. Release the button. The START/STOP button will illuminate after the button is released.

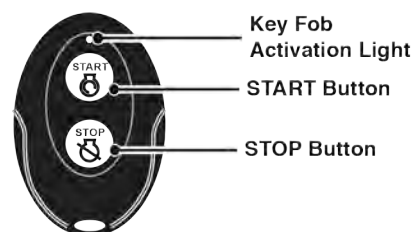

- Push and hold the START button on the key fob until the START/STOP button illumination turns OFF. Release the button. The START/STOP button will illuminate after the button is released.
- Push the Pairing button on the side of the control panel until the START/STOP button illumination turns OFF. Release the button.
- Turn the generator battery switch to the OFF position. The remote is now paired.

OPERATION

FUEL SELECTOR SWITCH

Position the fuel selector switch on the front control panel to the desired fuel choice.

Turn the fuel selector switch fully upward for gasoline operation.



Turn the fuel selector switch fully downward for propane operation.



BREAK-IN PERIOD

For proper break-in, do not exceed 50% of the rated running watts (3750 watts) during the first five hours of operation.

Vary the load occasionally to allow stator windings to heat and cool and help seat the piston rings.

BEFORE STARTING THE GENERATOR

Verify that:

- The generator is placed in a safe, appropriate location.
- The generator is on a dry, flat, and level surface.
- The engine is filled with oil.
- All loads are disconnected.

⚠ DANGER

Fire and explosion hazard. DO NOT move or tip the generator during operation.

STARTING THE ENGINE: GASOLINE

1. Verify that fuel is in the gas tank.
2. Turn the fuel selector switch on the control panel to gasoline operation.
3. Turn the fuel tank valve to the ON position.

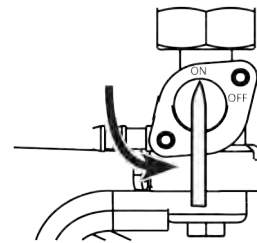

4. Push the battery switch to the ON position.
5. Choose the starting method:

- a. Remote Start:** Push and hold the START button on the remote start key fob for one second.
- b. Push-Button Start:** Push and hold the engine START/STOP button for two seconds.
- c. Recoil Start:** Manually close the choke if the engine is cold. Firmly grasp and pull the recoil handle slowly until you feel increased resistance, then pull rapidly.
Cold start: Close the choke by moving it right toward the front handle of the generator.

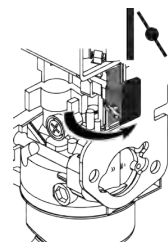

STARTING THE ENGINE: PROPANE

▲ DANGER

Fire and explosion hazard. Always turn the propane tank valve to the fully closed position if not running the generator on propane.

1. Make sure the LPG/propane hose is correctly connected to the generator and propane tank.
 2. Turn the fuel selector switch to propane operation.
 3. Fully open the valve on the propane tank.
 4. Push the battery switch to the ON position.
 5. Choose the starting method:
 - a. **Remote Start:** Push and hold the START button on the remote start key fob for one second.
 - b. **Push-Button Start:** Push and hold the engine START/STOP button for two seconds.
 - c. **Recoil Start:** Manually close the choke if the engine is cold. Firmly grasp and pull the recoil handle slowly until you feel increased resistance, then pull rapidly.
- Cold start:** Close the choke by moving it right toward the front handle of the generator.

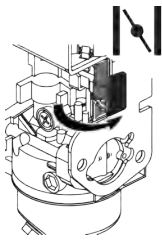

Note: During Push-Button or Remote Start the engine will automatically set the choke and begin the start sequence. If the engine fails to start, the generator will attempt to start the engine two more times.

SWITCHING FUEL SOURCES

▲ DANGER

Fire and explosion hazard. DO NOT add gasoline to the fuel tank or connect the LPG/propane hose to the generator while the generator is in operation.

The fuel source can be switched while the engine is running if a propane tank is connected to the generator BEFORE operation.

GASOLINE TO PROPANE

IMPORTANT: Load capacity is reduced when running on propane. Make sure the generator can supply enough (running) and surge (starting) watts for the items you are powering before switching to propane.

1. Fully open the valve on the propane tank.
2. Turn the fuel selector switch to propane operation.
3. Turn the fuel tank valve to the OFF position.

PROPANE TO GASOLINE

1. Turn the fuel tank valve to the ON position.
2. Turn the fuel selector switch to gasoline operation.
3. Turn the propane tank valve to the fully closed position.

Note: When switching to propane operation the engine may run rough for a few seconds while it purges gasoline in the carburetor.

If the engine stops when switching fuel sources, disconnect all loads then restart the unit on the fuel source of choice.

STOPPING THE ENGINE

1. Turn off and unplug all connected electrical loads.

IMPORTANT: Never start or stop the generator with electrical devices connected.

2. Let the generator run with no load for several minutes to stabilize internal temperatures of the engine.
3. Push and hold the START/STOP button for one second or push STOP on the remote start key fob for one second.

Note: Alternately, if the generator is used infrequently, turn the fuel tank valve to the OFF position to limit the residual fuel remaining in the carburetor float bowl. The engine will stop when fuel in the carburetor and fuel line is exhausted.

4. Push the battery switch to the OFF position.
5. If operating on LPG, turn the propane tank valve to the fully closed position.

FREQUENCY OF USE

If the generator will be used on an infrequent or intermittent basis (more than one month before next use), refer to the Battery Maintenance and Storage sections of this manual for information regarding battery charging and fuel deterioration.

OPERATION

AC CIRCUIT BREAKERS

The circuit breakers will automatically switch OFF if there is a short circuit or a significant overload of the generator at each receptacle. The main circuit breaker will automatically switch OFF if the combined load of the receptacles exceeds 40 Amps.

If an AC circuit breaker switches OFF automatically, check that the appliance is working correctly and it does not exceed the rated load capacity of the circuit before resetting the AC circuit breaker ON.

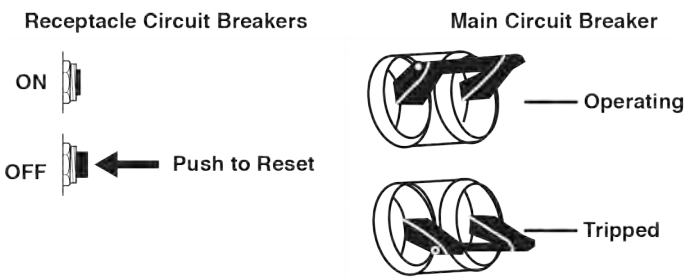

GENERATOR CAPACITY

NOTICE

Do not overload the generator's capacity. Exceeding the generator's wattage/amperage capacity can damage the generator and/or electrical devices connected to it.

Make sure the generator can supply enough continuous (running) and surge (starting) watts for the items you will power at the same time.

The total power requirements (Volts x Amps = Watts) of all appliances connected must be considered. Appliance and power tool manufacturers usually list rating information near the model or serial number.

To determine power requirements:

1. Select the items you will power at the same time.
2. Total the continuous (running) watts of these items. This is the amount of power the generator must produce to keep the items running. See the wattage reference chart on the next page.
3. Estimate how many surge (starting) watts you will need. Surge wattage is the short burst of power needed to start electric motor-driven tools or appliances such as a circular saw or refrigerator. Because not all motors start at the same time, total surge watts can be estimated by adding only the item(s) with the highest additional surge watts to the total rated watts from step 2.

Example:

Tool or Appliance	Running Watts*	Starting Watts*
RV Air Conditioner (11,000 BTU)	1010	1600
TV (Tube Type)	300	0
RV Refrigerator	180	600
Radio	200	0
Light (75 Watts)	300	0
Coffee Maker	600	0
	2590 Total Running Watts*	1600 Highest Starting Watts*
	Total Running Watts	2590
	Highest Starting Watts	+ 1600
	Total Starting Watts Needed	4190

*Wattages listed are approximate. Verify actual wattage.

POWER MANAGEMENT

To prolong the life of the generator and attached devices, use care when adding electrical loads to the generator. There should be nothing connected to the generator outlets before starting the engine. The correct and safe way to manage generator power is to sequentially add loads as follows:

1. With nothing connected to the generator, start the engine as described in this manual.
2. Plug in and turn on the first load, preferably the largest load you have.
3. Permit the generator output to stabilize (engine runs smoothly and attached device operates properly).
4. Plug in and turn on the next load.
5. Again, permit the generator to stabilize.
6. Repeat steps 4 and 5 for each additional load.

OPERATION

Wattage Reference

Tool or Appliance	Estimated Running Watts*	Estimated Starting Watts*
Incandescent Lights (4 Quantity x 75 Watts)	300	0
TV (Tube Type)	300	0
Sump Pump (1/3 hp)	800	1300
Refrigerator or Freezer	700	2200
Well Pump (1/3 hp)	1000	2000
Furnace (1/2 hp)	800	2350
Radio	200	0
Drill (3/8", 4 amps)	440	600
Circular Saw (Heavy Duty, 7-1/4")	1400	2300
Miter Saw (10")	1800	1800
Table Saw (10")	2000	2000

*Wattages listed are approximate. Verify actual wattage.

- Make sure the electrical rating of the tool or appliance does not exceed the rated power of the generator or the receptacle being used.

EXTENSION CORD SIZING

Only use grounded 3-prong extension cords marked for outdoor use that are rated for the electrical load.

Total Amperage	Minimum Gauge, Outdoor Rated	
	Up to 50 FT (15 M)	Up to 100 FT (30 M)
Up to 10A	12	8
Up to 15A	10	8
Up to 20A	10	6
Up to 30A	8	6
Up to 35A	6	6

EXTENSION CORDS

⚠ WARNING

Asphyxiation hazard. Extension cords running directly into the home increase the risk of carbon monoxide poisoning through any openings. If an extension cord running directly into your home is used to power indoor items, there is a risk of carbon monoxide poisoning to people inside the home. Always use battery-powered carbon monoxide detector (s) that meet current UL 2034 safety standards when running the generator. Regularly check the detector (s) battery.

⚠ WARNING

Asphyxiation hazard. When operating the generator with extension cords, make sure the generator is located in an open, outdoor area, far away from occupied spaces with exhaust pointed away.

⚠ WARNING

Fire and electrocution hazard. Never use worn or damaged extension cords. Damaged or overloaded extension cords could overheat, arc, and burn resulting in death or serious injury.

Before connecting an AC appliance or power cord to the generator:

- Use grounded 3-prong extension cords, tools, and appliances, or double-insulated tools and appliances.
- Make sure the tool or appliance is in good working order. Faulty appliances or power cords can create a potential for electric shock.

ST SWITCH

The wGen7500DF is compatible with the ST Switch, purchased separately. When utility power is on it will provide power (up to 120V @ 20A) to the appliances plugged into the 5-20R receptacle on the ST Switch. When utility power is lost the ST Switch automatically transfers input power from utility to generator power. When utility power is restored, the ST Switch transfers input power back to utility. Visit www.westinghouseoutdoorpower.com for more information.

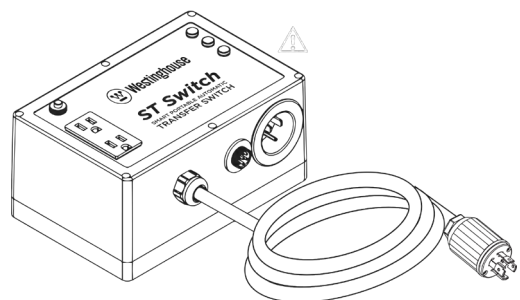

OPERATION

TRANSPORTING

⚠ CAUTION

Weight hazard. Always have assistance when lifting the generator.

- Allow the generator to cool a minimum of 30 minutes before transporting.
- If operating on LPG, turn the propane tank valve to the fully closed position.
- Disconnect the LPG/propane hose from the generator and propane tank.
- Replace all protective covers on the generator control panel.
- Only use the generator's fixed frame to lift the unit or attach any load restraints such as ropes or tie-down straps. Do not attempt to lift or secure the generator by holding onto any of its other components.
- Keep the unit level during transport to minimize the possibility of fuel leakage or, if possible, drain the fuel or run the engine until the fuel tank is empty before transport.
- The generator wheels are only intended for hand transport. The wheels are not suitable for towing the generator either on or off-road.
- Use the extendable handle for one-person, hand transport. Only use the handle while the generator is OFF, stationary, and resting on a horizontal surface. Do not use the handle to lift the generator entirely off the ground, tow it, or up-end it.

⚠ CAUTION

Fire hazard. Do not up-end the generator or place it on its side. Fuel or oil can leak and damage to the generator may occur.

MAINTENANCE

⚠ WARNING

Accidental start-up. Disconnect the spark plug boot from the spark plug and disconnect the battery quick-connect plugs when performing maintenance on the generator.

MAINTENANCE SCHEDULE

Regular maintenance will improve performance and extend the service life of the generator. Follow the hourly or calendar intervals, whichever occurs first. More frequent service is required when operating in adverse conditions as noted below.

Before Each Use
Check engine oil
After First 25 Hours or First Month
Change engine oil
After 50 Hours or Every 6 Months
Change engine oil ¹ Clean air filter ²
After 100 Hours or Every 6 Months
Inspect/clean spark arrestor Inspect/clean spark plug Replace fuel filter Inspect/adjust valve clearance ³
After 300 Hours or Every Year
Replace spark plug Replace air filter

¹ Change oil every month when operating under heavy load or in high temperatures.

² Clean more often under dirty or dusty conditions. Replace air filter if it cannot be adequately cleaned.

³ Recommend service to be performed by authorized Westinghouse service dealer.

MAINTENANCE REMINDERS

Maintenance reminder codes will be shown on the Data Display based on unit Lifetime Hours. The maintenance codes will be displayed until the unit is turned off. Refer to the Maintenance section for specific procedures.

Maintenance Code	Required Maintenance
P25	Change engine oil
P50	Change engine oil, clean air filter
P100	Change engine oil, clean air filter, replace fuel filter

MAINTENANCE REPLACEMENT PARTS

Description	Part Number
Air filter	5046
Oil drain plug crush washer	94004
Spark arrestor	6866
Battery, 9.0 AH	511008
Fuel filter	516401
Spark plug	<ul style="list-style-type: none"> • Torch - F7TC • NGK - BP7ES • Champion - 332 • Autolite - 62

AIR FILTER MAINTENANCE

⚠ WARNING

Fire hazard. Never use gasoline or other flammable solvents to clean the air filter. Use only household detergent soap to clean the air filter.

The air filter must be cleaned after every 50 hours of use or six months (frequency should be increased if the generator is operated in a dusty environment).

1. Place the generator on a level surface and allow the engine to cool for several minutes.
2. Release the top and bottom clamps then remove the air filter cover.

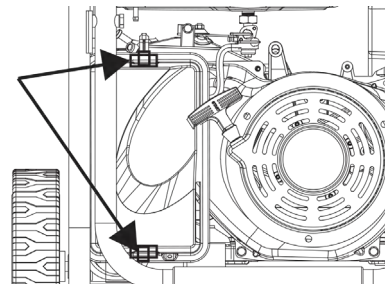

3. Remove the air filters. Use compressed air to clean the coarse air filter.

Note: The foam air filter element is oil soaked. Use an appropriate cleaning container.

NOTICE

Avoid skin contact with engine oil. Wear protective clothing and equipment. Wash all exposed skin with soap and water.

4. Remove the foam air filter and wash it by submerging the element in a solution of household detergent soap and warm water. Slowly squeeze the foam to thoroughly clean.

MAINTENANCE

NOTICE

DO NOT twist or tear the foam air filter element during cleaning or drying. Only apply slow but firm squeezing action.

- Rinse the air filter element by submerging it in fresh water and applying a slow squeezing action. Allow the filter to dry thoroughly.

NOTICE

Do not pollute. Follow the guidelines of the EPA or other governmental agencies for proper disposal of hazardous materials. Consult local authorities or reclamation facility.

- Dip the foam air filter in clean engine oil then squeeze out all excess oil. The engine will smoke when started if too much oil is left in the filter.
- Install the foam air filter in the housing, then the coarse air filter. Install the air cleaner cover and secure with the cover clamps.

ENGINE OIL LEVEL CHECK

⚠ CAUTION

Avoid skin contact with engine oil. Wear protective clothing and equipment. Wash all exposed skin with soap and water.

NOTICE

Always use the specified engine oil. Failure to use the specified engine oil can cause accelerated wear and/or shorten the life of the engine.

When using the generator under extreme, dirty, dusty conditions or in extremely hot weather, change the oil more frequently.

Ambient air temperature will affect engine oil performance. Change the type of engine oil used based on weather conditions.

Recommended Engine Oil Type								
		10W-30						→
←	5W-30				10W-40		→	
	5W-30 Synthetic							
°F	-20	0	20	40	60	80	100	120
°C	-28.9	-17.8	-6.7	4.4	15.6	26.7	37.8	48.9
Ambient temperature								

Check the engine oil level before each use or every 8 hours of operation.

- Place the generator on a level surface and allow the engine to cool for several minutes.
- With a damp rag, clean around the oil dipstick.
- Remove the oil dipstick and wipe the dipstick clean.

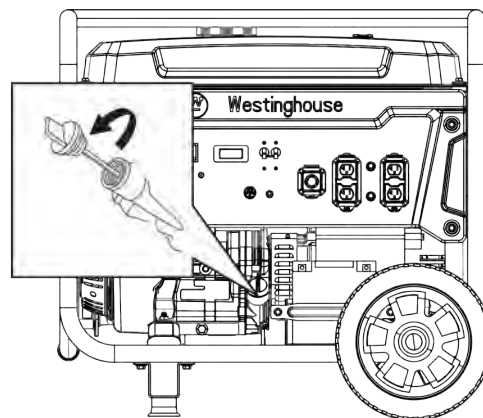

MAINTENANCE

- Wipe the dipstick clean, then insert it into the oil filler neck without screwing it in. Remove the dipstick and verify that the oil level is within safe operating range..

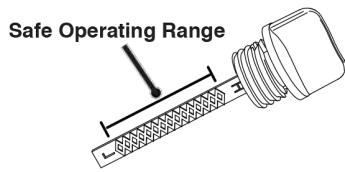

- If low, add recommended engine oil incrementally and recheck until the level is between the L and H marks on the dipstick. DO NOT overfill. If over the full mark on the dipstick, drain the oil to reduce the oil level to the full mark.

- Replace the oil dipstick and hand-tighten.

ENGINE OIL CHANGE

When using the generator under extreme, dirty, dusty conditions or in extremely hot weather, change the oil more frequently. Change the oil while the engine is still warm from operation.

- Place the generator on a level surface and allow the engine to cool for several minutes.
- With a damp rag, clean around the oil dipstick. Remove the dipstick and wipe clean.
- Place an oil pan (or suitable container) under the oil drain bolt.
- Using a 10mm wrench, remove the oil drain bolt and allow the oil to drain.

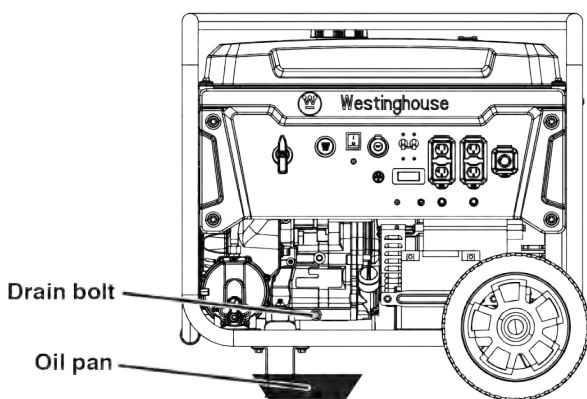

- Install the oil drain bolt and tighten securely.

Note: A new oil drain plug crush washer is recommended at each oil change.

- Slowly pour oil into the oil filler neck until the level is between the L and H marks on the dipstick. Stop frequently to check the oil level. DO NOT overfill.

Maximum oil capacity: 1.16 Quart (1.1 Liter)

- Install the oil dipstick and hand-tighten.

NOTICE

Do not pollute. Follow the guidelines of the EPA or other governmental agencies for proper disposal of hazardous materials. Consult local authorities or reclamation facility.

SPARK PLUG MAINTENANCE

Inspect and clean the spark plug after every 100 hours of use or six months. Replace the spark plug after 300 hours of use or every year.

- Place the generator on a level surface and allow the engine to cool.
- Remove the spark plug boot by firmly pulling the spark plug boot directly away from the engine.
- Clean the area around the spark plug.
- Remove the spark plug with the included spark plug socket wrench.

NOTICE

Never apply any side load or move the spark plug laterally when removing the spark plug.

- Inspect the spark plug. Replace if electrodes are pitted, burned, or the insulator is cracked. Only use a recommended replacement plug.

Recommended Spark Plug Replacement

Westinghouse Model Number	Torch	NGK	Champion	Autolite
WGen7500DF	F7TC	BP7ES	332	62

- Measure the spark plug electrode gap with a wire-type feeler gauge. If necessary, correct the gap by carefully bending the side electrode.

Spark plug gap: 0.024 – 0.032 in. (0.60 – 0.80 mm)

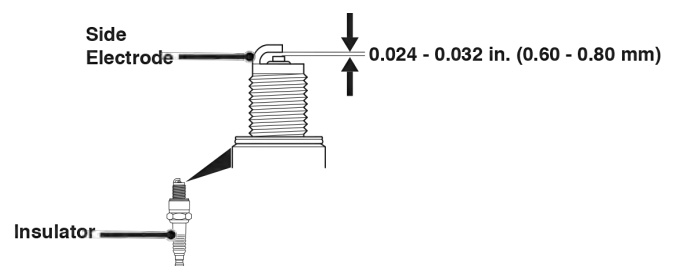

- Carefully install the spark plug finger tight, then tighten as additional 3/8 to 1/2 turn with the spark plug wrench.
- Attach the spark plug boot.

MAINTENANCE

SPARK ARRESTOR SERVICE

Allow the muffler to cool completely before servicing the spark arrestor. Check and clean the spark arrestor after every 100 hours of use or six months. Failure to clean the spark arrestor will result in degraded engine performance.

1. Place the generator on a level surface.
2. Remove the cover screws and the muffler cover. Use a screw driver to remove the spark arrestor.

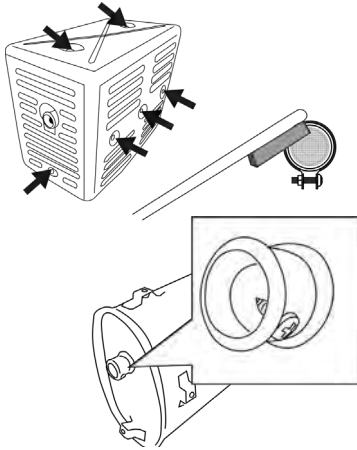

3. Carefully remove the carbon deposits from the spark arrestor screen with a wire brush. The spark arrestor must be free of breaks and tears. Replace the spark arrestor if damaged.
4. Reinstall the spark arrestor and muffler cover.

FUEL FILTER

Replace the fuel filter after 100 hours of use.

Note: Have an appropriate gasoline container and rags ready to catch residual fuel in the filter and fuel line.

1. Allow the generator to cool completely.
2. Turn the fuel valve to the OFF position.

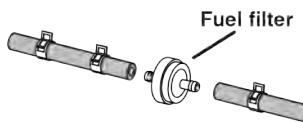

3. Note the orientation of the fuel filter. Using pliers, remove the fuel line clamps and remove the fuel filter.
4. Install the new fuel filter in the reverse order of removal.

BATTERY MAINTENANCE

The battery shipped with the generator has been fully charged. A battery may lose some charge when not in use for prolonged periods of time.

Note: Once started, the generator will charge the battery after 30–60 minutes of use.

The included trickle charger can remain connected and will maintain the battery for an indefinite period of time. A red light on the charger indicates charging in progress. A green light indicates charging complete. Charge in a dry location.

1. Plug the charger into the battery charging port on the control panel.
2. Plug the wall receptacle end of the battery charger into a 120 Volt AC wall outlet.

BATTERY REPLACEMENT

⚠ WARNING

Burn hazard. The battery contains sulfuric acid (electrolyte) which is highly corrosive and poisonous. Wear protective clothing and eye protection when working near the battery. Keep children away from the battery.

⚠ CAUTION

Battery posts, terminals contain lead and lead compounds. Wash hands after handling.

1. Loosen and remove the bolt on the battery hold-down plate and swing the plate out.
2. Disconnect the quick-connect plugs and remove the battery from the unit.
3. Disconnect the quick-disconnect cable leads from the battery.
4. On the replacement battery, connect the white (-) quick-connect cable to the battery negative terminal. Slide the rubber boot over the connection hardware.
5. Connect the red (+) quick-connect cable to the battery positive terminal. Slide the rubber boot over the connection hardware.
6. Install the battery into the generator. Reinstall the battery hold-down plate and tighten the bolt.
7. Connect the quick-connect plug.

NOTICE

Dispose of the used battery properly according to the guidelines established by your local or state government.

STORAGE

Proper storage preparation is required for trouble-free operation and generator longevity.

NOTICE

Gasoline stored for as little as 30 days can deteriorate, causing gum, varnish, and corrosive buildup in fuel lines, fuel passages, and the engine. This corrosive buildup restricts the flow of fuel, which can prevent the engine from starting after a prolonged storage period. The use of fuel stabilizer significantly increases the storage life of gasoline. Full-time use of fuel stabilizer is recommended. Follow the manufacturer's instructions for use.

STORAGE TIME	RECOMMENDED PROCEDURE
Less than 1 month	No service required.
2 to 6 months	Fill with fresh gasoline and add gasoline stabilizer. Drain the carburetor float bowl.
6 months or longer	Drain the fuel tank and carburetor float bowl.

SHORT TERM STORAGE

- Allow the generator to cool a minimum of 30 minutes before storage.
- If operating on LPG, turn the propane tank valve to the fully closed position and disconnect the LPG/propane hose from the generator and propane tank.
- Replace all protective covers on the generator control panel.
- Wipe the generator with a moist cloth. Clean any debris from the muffler cooling vents.
- Store the generator in a well-ventilated, dry location away from sparks, open flames, pilot lights, heat, and other sources of ignition such as areas with a spark-producing electric motor or where power tools are operated.
- Do not store the generator, gasoline, or propane tanks near furnaces, water heaters, or any other appliances that produce heat or have automatic ignitions.
- With the engine and exhaust system cool and all surfaces dry, cover the generator to keep out dust. Do not use a plastic sheet as a dust cover. Non-porous materials trap moisture and promote rust and corrosion.

LONG TERM STORAGE

Even properly stabilized fuel can leave residue and cause corrosion if left long term. If storing the generator for two to six months, drain the float bowl to prevent gum and varnish buildup in the carburetor.

DRAINING THE FLOAT BOWL

1. Turn the fuel tank valve to the OFF position.
2. Locate the drain screw on the bottom of the carburetor float bowl.

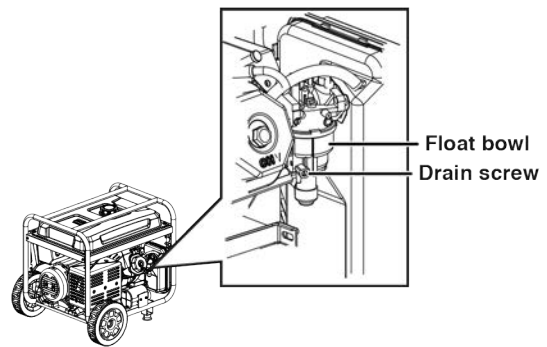

3. Place an appropriate gasoline container under the drain screw to catch the drained fuel.
4. Loosen the float bowl drain screw and allow the fuel to drain. Tighten the float bowl drain screw.

MAINTENANCE

DRAINING THE FUEL TANK

If storing the generator for longer than six months, drain the fuel tank to prevent fuel separation, deterioration, and deposits in the fuel system.

1. Unscrew the fuel tank cap. Remove the fuel screen filter by slightly compressing it while removing it from the tank.
2. Using a commercially available gasoline hand pump (not included), siphon the gasoline from the fuel tank into an approved gasoline container. DO NOT use an electric pump.
3. Reinstall the fuel screen filter and the fuel tank cap.
4. Start the generator and allow it to run until the generator engine stops.
5. Push the battery switch to the OFF position.
6. Disconnect the battery quick-connect plugs.
7. Remove the spark plug.
8. Put a teaspoon of engine oil into the cylinder and pull the recoil handle until resistance is felt. At this position the piston is coming up on its compression stroke and both valves are closed. Storing the engine in this position will help prevent internal corrosion. Return the recoil handle gently.
9. Reinstall the spark plug. Leave the spark plug boot disconnected to prevent accidental starting.

VALVE CLEARANCE

NOTICE

Checking and adjusting valve clearance must be done when the engine is cold.

1. Remove the rocker arm cover and carefully remove the gasket. If the gasket is torn or damaged, it must be replaced.
2. Remove the spark plug so the engine can be rotated more easily.
3. Rotate the engine to top dead center (TDC) by pulling the recoil handle slowly. Looking through the spark plug hole, the piston should be at the top (both valves are closed).
4. Both the rocker arms should be loose at TDC on the compression stroke. If they are not, rotate the engine 360°.
5. Insert a feeler gauge between the rocker arm and the valve stem to measure valve clearance.

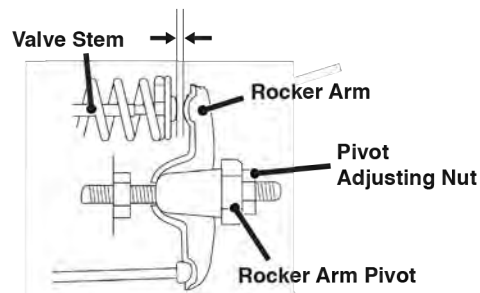

	Intake Valve	Exhaust Valve
Valve Clearance	0.0031 – 0.0047 in (0.08 – 0.12 mm)	0.0051 – 0.0067 in (0.13 – 0.17 mm)
Torque	8-12 N•m	8-12 N•m

6. If an adjustment is necessary, hold the rocker arm pivot and loosen the pivot adjusting nut.
 7. Turn the rocker arm pivot to obtain the specified clearance. Hold the rocker arm pivot and re-tighten the pivot adjusting nut to the specified torque.
- Torque: 106 inch-pound (12 N•m)**
8. Perform this procedure for the other valve.
 9. Install the gasket, rocker arm cover, and spark plug.

TROUBLESHOOTING

TROUBLESHOOTING

PROBLEM	POSSIBLE CAUSE	CORRECTION
Engine will not start	Battery switch in the OFF position.	Turn battery switch to the ON position.
	Out of fuel.	Refuel.
	Bad fuel, generator stored without treating or draining gasoline, or refueled with bad gasoline.	Drain the fuel tank. Refuel with fresh gasoline.
	Dirty air filter.	Clean the air filter.
	Low engine oil level stopped generator.	If low oil LED illuminated, turn battery switch to the OFF position. Add engine oil.
	Spark plug wet with fuel (flooded engine).	Wait five minutes. Turn battery switch to the OFF position. Pull recoil handle rapidly several times. If the generator does not start, remove spark plug and dry.
	Spark plug faulty, fouled, or improperly gapped.	Gap or replace the spark plug. Reinstall.
	Fuel filter restricted, fuel system malfunction, fuel pump failure, ignition malfunction, valves stuck, etc.	Contact Westinghouse customer service toll-free at 1 (855) 944-3571.
	Battery drained.	Use the recoil handle to start the generator. Charge the battery.
	Choke partially open or closed due to weak or disconnected battery.	Manually set the choke. See Maintenance section.
Engine starts, then shuts down	Out of fuel.	Refuel.
	Incorrect engine oil level.	Check engine oil level.
	Dirty air filter.	Clean the air filter.
	Contaminated fuel.	Drain the fuel tank. Refuel with fresh gasoline.
	Defective low oil level switch.	Contact Westinghouse customer service toll-free at 1 (855) 944-3571.
Engine lacks power	Air filter restricted.	Clean or replace air filter.
	Bad fuel, generator stored without treating or draining gasoline, or refueled with bad gasoline.	Drain the fuel tank. Refuel with fresh gasoline.
	Fuel filter restricted, fuel system malfunction, fuel pump failure, ignition malfunction, valves stuck, etc.	Contact Westinghouse customer service toll-free at 1 (855) 944-3571.
Engine runs rough or bogs when load applied	Dirty air filter.	Clean the air filter.
	Generator overloaded.	Unplug some devices.
	Faulty power tool or appliance.	Replace or repair tool or appliance. Stop and restart the engine.
	Fuel filter restricted, fuel system malfunction, fuel pump failure, ignition malfunction, valves stuck, etc.	Contact Westinghouse customer service toll-free at 1 (855) 944-3571.
No power at AC receptacles	OUTPUT READY LED is OFF and OVERLOAD LED is ON.	Check AC load. Stop and restart engine. Check the air inlet. Stop and restart the engine.
	AC circuit breaker/s tripped.	Check AC loads and reset circuit breaker/s.
	Faulty power tool or appliance.	Replace or repair tool or appliance. Stop and restart the engine.
	Faulty generator.	Contact Westinghouse customer service toll-free at 1 (855) 944-3571.

TROUBLESHOOTING

PROBLEM	POSSIBLE CAUSE	CORRECTION
Frost on the propane tank or regulator	If the temperature of the propane tank drops below the dew point, condensation on the tank may turn to frost or ice. This typically occurs in humid conditions.	Providing all the propane fuel handling equipment is functioning normally, no correction is needed.
	The Propane tank is not equipped with an Overfilling Prevention Device (OPD).	If you suspect your propane fuel tank is not equipped with an OPD device, discontinue operation immediately and replace the propane fuel tank with a propane tank equipped with a an OPD.
	Propane fuel tank overfilled.	If you suspect your propane fuel tank has been overfilled, discontinue operation immediately and return the propane fuel tank to the place of purchase or refilling.
Propane fuel smell	Fuel regulator or fuel hose and fittings not securely sealed.	Using a soap solution check each connection and tighten as needed.
	Propane fuel regulator vent active.	The propane fuel regulator is equipped with a vent that will allow a small amount of propane fuel vapor to escape from the regulator when the propane tank valve is opened. This can be normal providing the venting of the propane is brief. If you suspect that this is abnormal, immediately discontinue use and have the propane regulator inspected by a qualified technician.
	Residual fuel from the carburetor dispersing after operation.	Normal, no correction is needed.
Poor performance or engine stalling on Propane	Propane fuel line kinked or crushed.	Inspect propane fuel line and remove kinks or other obstructions.
	Fuel selector valve not properly positioned.	Rotate the fuel valve fully until the pointer is directly in line with the desired fuel.
	Gasoline not purged from the carburetor before switching to propane.	Close the propane fuel tank valve. Move the fuel selector switch to gas. Start the engine and allow the engine to run until the gasoline has been consumed in the carburetor. Begin propane start up procedure.

EXPLODED VIEW

EXPLODED VIEW A



EXPLODED VIEW

EXPLODED VIEW A

NO.	PART#	DESCRIPTION
1		CRANKCASE ASSEMBLY
1.1	260218	CRANKCASE
1.2	93002	AXLE BEARING
1.3	93512	CRANKCASE OIL SEAL
1.4	93516	SWING ROD OIL SEAL
1.5	263901	RACKING BAR
1.6	96806	SWINGING ROD GASKET
1.7	263902	RETAINING CLAMP
1.8	265102	OIL SENSOR ASSEMBLY
1.9	91329	BOLT M6X16
1.10	91333	BOLT M6*28
1.11	269901	RUBBER CABLE BLOCK
1.12	97213	CHARGING COIL
2	260319	CRANKSHAFT
3	260301	BALANCE SHAFT
4		CRANKCASE COVER ASSEMBLY
4.1	93002	AXLE BEARING
4.2	93512	CRANKCASE OIL SEAL
4.3	240904	CRANKCASE LOCATING PIN
4.4	260111	CRANKCASE COVER
4.5	93015	AXLE BEARING
4.6	264301	CENTRIFUGAL GOVERNOR GEAR ASSEMBLY
4.7	96072	CRANKCASE SEAL WASHER
4.8	91349	BOLT M8X40
4.9	265604-295	DIPSTICK
5		ALTERNATOR ASSEMBLY
5.1	266101	VALVE LIFTER
5.2	272003	CAMSHAFT ASSEMBLY
5.3	261901	PUSH ROD
6		SPEED GOVERNOR ASSEMBLY
6.1	264001	SPEED REGULATING ARM
6.2	91325	BOLT M6X12
6.3	264404	SPEED CONTROLLER
6.4	262701	THROTTLE LEVER
6.5	264201	SPRING C
6.6	264101	SPRING B
7		PISTON & PISTON RING ASSEMBLY
7.1	261205	PISTON
7.2	261604	PISTON RING ASSEMBLY
7.3	261503	CONNECTING ROD ASSEMBLY
7.4	265501	PISTON PIN
7.5	261301	PISTON PIN RING
8	97108	SPARK PLUG
9		CYLINDER HEAD ASSEMBLY
9.1	271005	CYLINDER HEAD
9.2	271702	INTAKE VALVE
9.3	275902	INTAKE VALVE
9.4	261807	EXHAUST VALVE
9.5	93513	VALVE SEAL
9.6	266002	VALVE SPRING

NO.	PART#	DESCRIPTION
9.7	260802	VALVE LOCK CLAMP
9.8	261805	AIR INLET SPRING SEAT
9.9	262201	VALVE RETAINER ASSEMBLY
9.10	262101	ROCKING ARM
9.11	261806	TOP CAP
9.12	91016	AIR INLET STUD BOLT
9.13	91007	AIR EXHAUST STUD BOLT
9.14	96083	EXHAUST SEAL WASHER
9.15	95207	MUFFLER CONNECTING PIPE
9.16	94206	SPRING WASHER
9.17	90011	NUT M8
9.18	91818	ROCKING ARM WITH TIGHT BOLT ASSEMBLY
9.19	260901	CYLINDER HEAD LOCATING PIN
9.20	96089	CYLINDER HEAD GASKET
9.21	91321	BOLT M10X80
9.22	270501	WIND-LEAD-COVER
9.23	91325	BOLT M6X12
9.24	96078	INTAKE SEALING WASHER
9.25	262301	CARBURETOR CONNECTION BLOCK
10		CYLINDER HEAD COVER ASSEMBLY
10.1	261104	CYLINDER HEAD COVER
10.2	91819	CYLINDER HEAD COVER FASTENING BOLT
10.3	95606	BLAST PIPE
11		CARBURETOR ASSEMBLY
11.1	262860	CARBURETOR ASSEMBLY
11.2	95730L	FUEL HOSE
11.3	94403	FUEL HOSE CLAMP
11.4	94401	FUEL HOSE RUBBER SLEEVE
11.5	260801	CABLE CLAMP
11.6	517903	LOW PRESSURE HOSE
11.7	92007	CROSS SCREW STUD M4*8
11.8	249905	STEPPER MOTOR DRIVE SHAFT
11.9	244202	SPRING
11.10	269909	BRACKET
11.11	249904	STEPPER MOTOR
11.12	599302	LOW PRESSURE HOSE HOOP
12		AIR FILTER ASSEMBLY
12.1	90016	NUT M6
12.2	262908-052	AIR CLEANER ASSEMBLY
13		IGNITER ASSEMBLY
13.1	97551	IGNITION COIL ASSEMBLY
13.2	91331	BOLT M6X25
14		FLYWHEEL ASSEMBLY
14.1	260402	FLYWHEEL
14.2	264601	IMPELLER
14.3	264501	STARTER PULLEY
14.4	90004	FLYWHEEL NUT

EXPLODED VIEW

EXPLODED VIEW A CONTINUED

NO.	PART#	DESCRIPTION
15		RECOIL STARTER ASSEMBLY
15.1	91325	BOLT M6X12
15.2	264738-221B	STARTER ASSEMBLY
15.3	5910-221	START PULLER
15.4	5943	PULL
16		STARTER MOTOR ASSEMBLY
16.1	97415	STARTING MOTOR ASSEMBLY
16.2	249901	WIRE CLAMP
16.3	91340	BOLT M6*8
16.4	269902	WIRE CLAMP
16.5	91348	BOLT M8*35
17	91817	OIL DRAIN BOLT
18	94004	OIL DRAIN BOLT WASHER
19	96075	HEAD COVER SEAL WASHER
20	96081	CARBURETOR WASHER
21	5205	AIR CLEANER ELEMENT
22	96086	AIR FILTER GASKET

EXPLODED VIEW

EXPLODED VIEW B

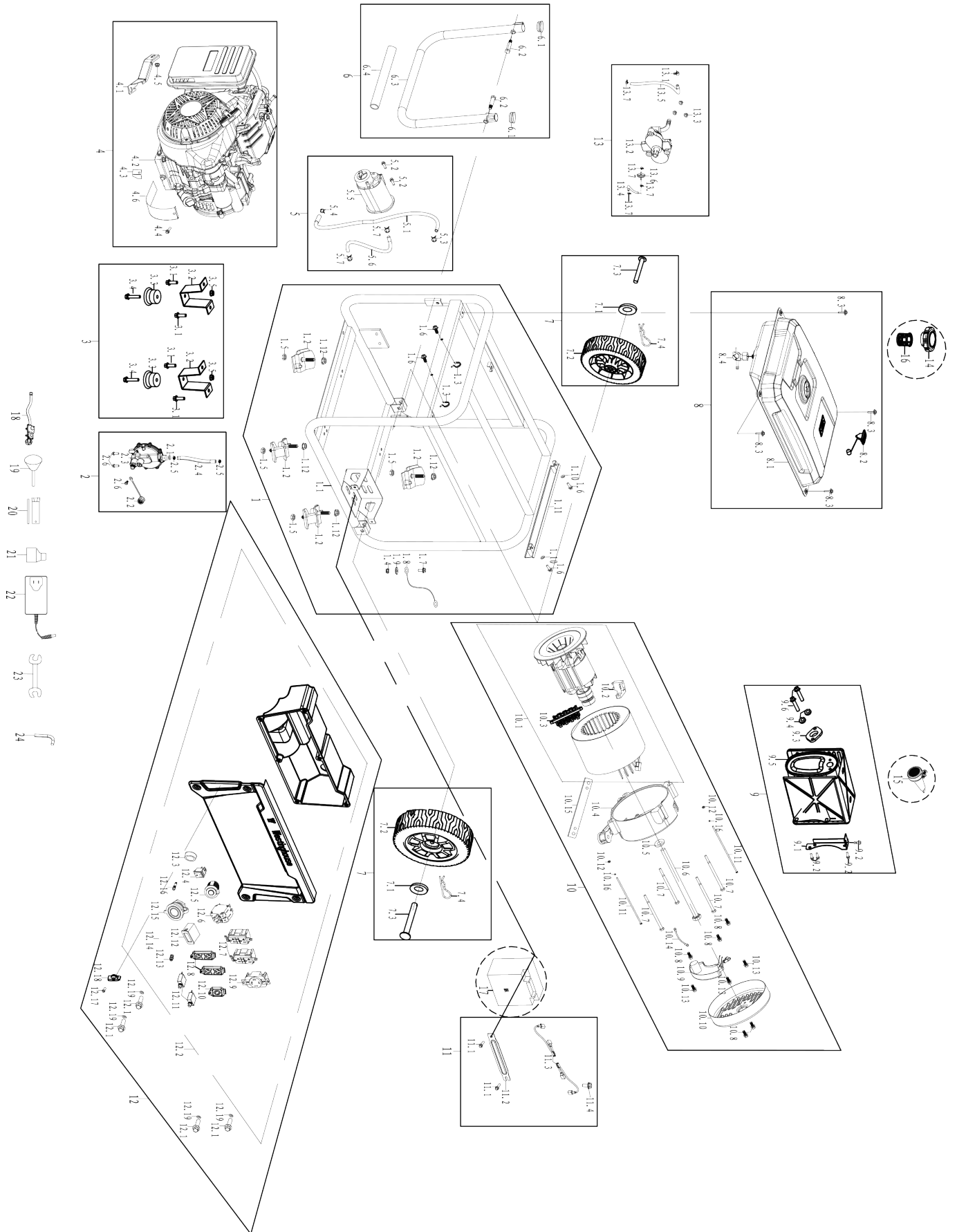

EXPLODED VIEW

EXPLODED VIEW B

NO.	PART#	DESCRIPTION
1		FRAME ASSEMBLY
1.1	774019-116	FRAME
1.2	531314	ISOLATOR
1.3	94447	FUEL HOSE CLAMP
1.4	90018	NUT M8
1.5	90011	NUT M8
1.6	91327	BOLT M6X12
1.7	91343	BOLT M8X16
1.8	544307	FRAME WIRE
1.9	94009	TOOTH WASHER Φ8
1.10	96120	PAPER WASHER
1.11	530606-116	FUEL TANK BRACKET
1.12	90013	NUT M10
2		PRESSURE REDUCING VALVE ASSEMBLY
2.1	96120	PAPER WASHER
2.2	519387	PROTECTIVE CASE
2.3	50280033	PRESSURE REDUCING VALVE ASSEMBLY
2.4	517328	LOW PRESSURE HOSE
2.5	599302	LOW PRESSURE HOSE HOOP Φ12
2.6	91325	BOLT M6X12
3		FOOT BRACKET ASSEMBLY
3.1	91343	BOLT M8X16
3.2	525608-116	FOOT BRACKET ASSEMBLY
3.3	531115	FOOT BRACKET SHOCK ABSORBER
3.4	91333	BOLT M6X28
3.5	90023	NUT M6
4		ENGINE ASSEMBLY
4.1	540601	AIR FILTER BRACKET
4.2	1148420220031	ENGINE ASSEMBLY
4.3	549603	DUST BOARD
4.4	91322	BOLT M5X12
4.5	90016	NUT M6
4.6	539602	CRANKCASE COVER
5		CARBON CANNISTER ASSEMBLY
5.1	95123	CARBON CANISTER AND FUEL TANK CONNECTING PIPE
5.2	91327	BOLT M6X12
5.3	94423	FUEL HOSE CLAMP
5.4	94408	FUEL HOSE CLAMP
5.5	543601L	CARBON CANISTER
5.6	95124	CONNECTING PIPE
5.7	94402	FUEL HOSE CLAMP
6		HANDLE ASSEMBLY
6.1	527603	HANDLE PLUG
6.2	527612	BOLT M10X12.5X53.5
6.3	526620-116	HANDLE
6.4	528607	HANDLE GUM COVER
7		WHEEL ASSEMBLY
7.1	94207	FLAT WASHER
7.2	523646	WHEEL

NO.	PART#	DESCRIPTION
7.3	524619	AXLE PIN
7.4	548302	COTTER PIN
8		FUEL TANK ASSEMBLY
8.1	700378L-116	FUEL TANK ASSEMBLY
8.2	6861	FUEL GAUGE
8.3	91460	BOLT M6X25
8.4	518208	FUEL SWITCH
9		MUFFLER ASSEMBLY
9.1	520305	MUFFLER BRACKET
9.2	91343	BOLT M8X16
9.3	96002	MUFFLER CONNECTING PIPE GASKET
9.4	94206	SPRING WASHER
9.5	705944	MUFFLER COMP
9.6	91347	BOLT M8X30
10		ALTERNATOR ASSEMBLY
10.1	757526	ROTOR STATOR ASSEMBLY THE MOTOR ASSEMBLY
10.2	599019	CARBON BRUSH
10.3	6560	TERMINAL ASSEMBLY
10.4	532301	REAR BEARING CARRIER MOTOR TAIL BRACKET
10.5	96813	GASKET Φ10.5XΦ30X4
10.6	91717	BOLT M10X1.25X275
10.7	91614	BOLT M6X190
10.8	91322	BOLT M5X12
10.9	534813	AVR VOLTAGE REGULATOR
10.10	533302-221	ALTERNATOR COVER
10.11	91512	BOLT M5X230
10.12	90009	NUT M5
10.13	91323	BOLT M5X16
10.14	544610	GROUNDING WIRE
10.15	532303-052	TAIL BRACKET FIXING PLATE
10.16	94204	SPRING WASHER
11		BATTERY
11.1	91327	BOLT M6X12
11.2	542614-116	BATTERY PRESSURE PLATE
11.3	512058	BATTERY WIRING ASSEMBLY
11.4	91325	BOLT M6X12
12		CONTROL PANEL ASSEMBLY
12.1	91327	BOLT M6X12
12.2	714316	PANEL ASSEMBLY
12.3	536002	ONE-KEY START SWITCH
12.4	6502	SWITCH
12.5	6796	DC SOCKET
12.6	6523	BREAKER
12.7	6275	SOCKET
12.8	6845	WATERPROOF CAP

EXPLODED VIEW

EXPLODED VIEW B CONTINUED

NO.	PART#	DESCRIPTION
12.9	6385	SOCKET
12.10	6848	WATERPROOF CAP
12.11	6439-20	22A THERMAL PROTECTOR
12.12	6041	DIGITAL DISPLAY
12.13	6386	GROUND BOLT ASSEMBLY
12.14	6387	CHARGING SOCKET
12.15	6488	AVIATION SOCKET
12.16	6393	INDICATOR LIGHT
12.17	92083	HEXAGON SOCKET PAN HEAD SCREWS
12.18	599035	SWITCH TURNTABLE ASSEMBLY
12.19	96120	PAPER WASHER
13		DUAL FUEL SELECTOR SWITCH
13.1	94403	FUEL HOSE CLAMP $\phi 7.5$
13.2	50280010	FUEL SWITCH ASSEMBLY
13.3	90015	NUT M5
13.4	95486L	FUEL HOSE
13.5	95723L	FUEL HOSE
13.6	516401	FILTER
13.7	503034	FUEL HOSE CLAMP $\phi 9.5 \times 0.8$
14	519215	FUEL CAP
15	6866	SPARK ARRESTER
16	518801	FUEL TANK FILTER
17	545331	BATTERY
18	99504	PRESSURE REDUCING VALVE
19	99010	FUNNEL
20	99546	SPARK PLUG SLEEVE
21	511076	OIL BOTTLE
22	99025	CHARGER
23	94432	WRENCH
24	511008	NYLON BRAIDED TUBE

SCHEMATICS

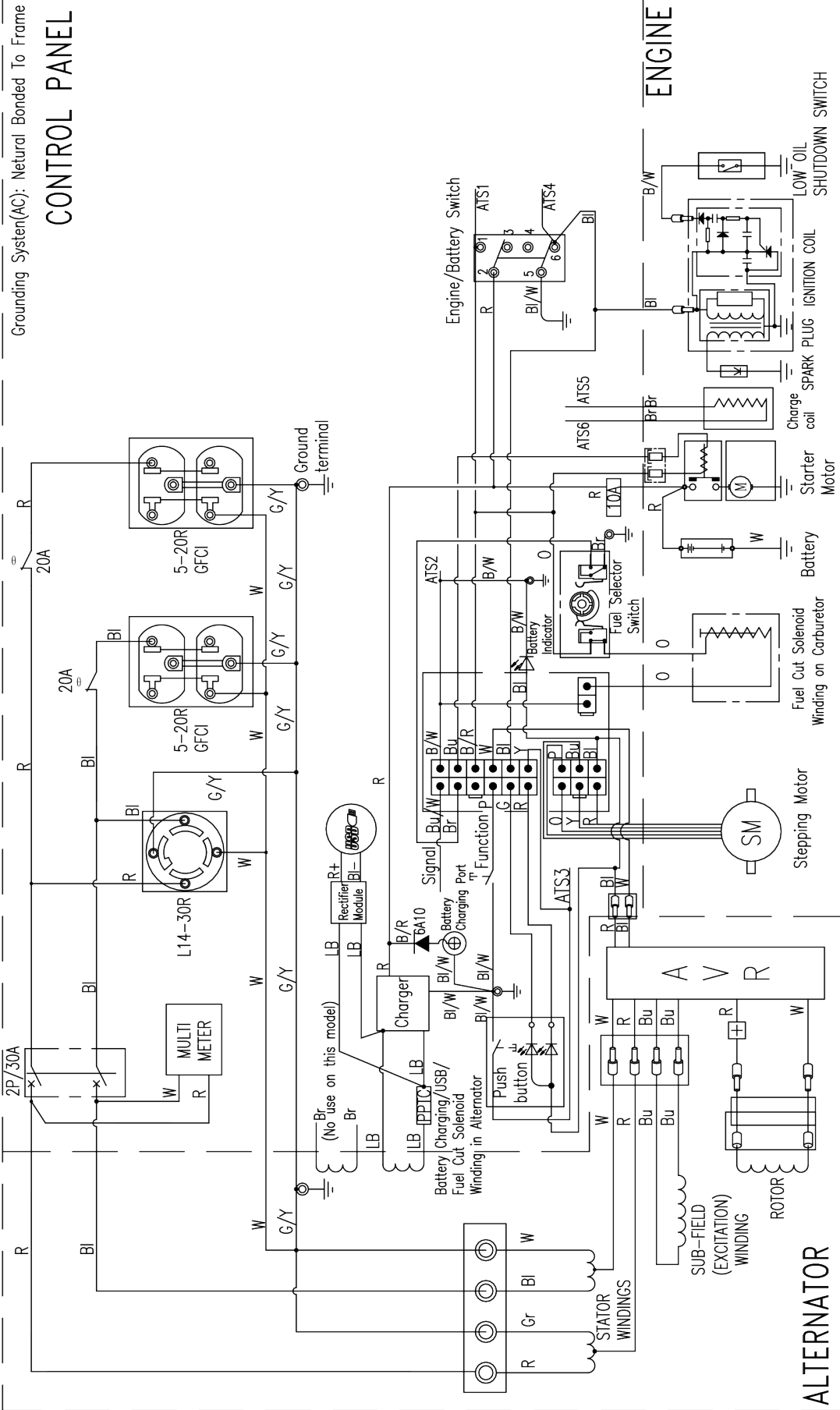

Bl	Black	Br	Brown	G/Y	Green/Yellow
O	Orange	Br/R	Brown/Red	Bl/W	Black/White
Bu	Blue	LB	Light Blue	P	Pink
Gr	Gray	Bl	Black	G	Green
R	Red	W	White	Y	Yellow
R/W	Red/White				