

Go to www.vtechbabycare.com to register your product for enhanced warranty support and the latest VTech product news.

RM5764HD
RM5764-2HD
5" Smart Wi-Fi 1080p
Pan and Tilt Monitor



For more support, email support@vtechbabycare.com or scan the QR code below for product information.

vtech

Quick start guide



Congratulations

on purchasing your new VTech product. Before using this baby monitor, please read the **Important safety instructions**.

WHAT'S IN THE BOX

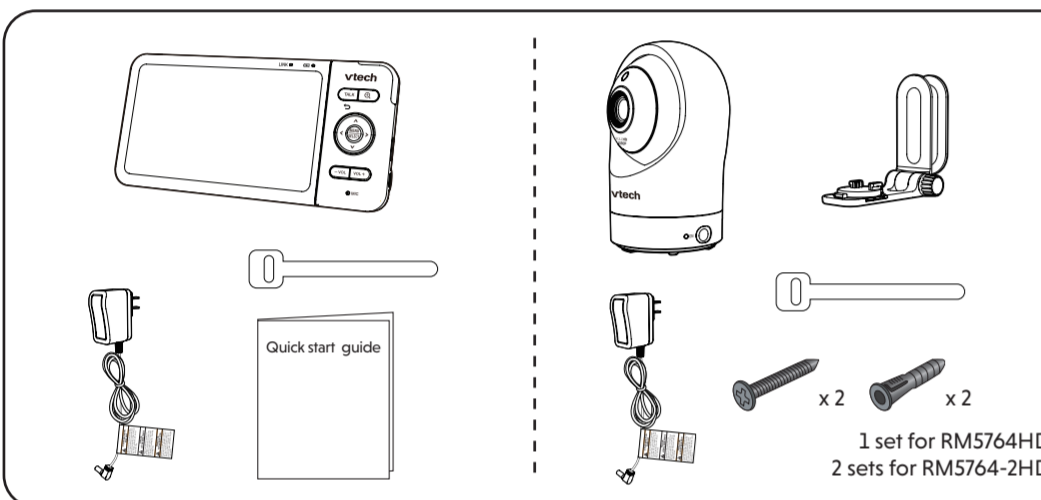

IMPORTANT SAFETY INSTRUCTIONS

The applied nameplate is located at the bottom of the baby unit base. When in use, basic safety precautions should always be followed to reduce the risk of fire, electric shock and injury, including the following:

- Follow all warnings and instructions marked on the product.
- Adult setup is required.
- CAUTION:** Do not install the baby unit at a height above 6.5 feet (2 meters).
- This product is intended as an aid. It is not a substitute for responsible and proper adult supervision and should not be used as such.
- This product is not intended for use as a medical monitor.
- Do not use this product near water, for example, near to a bath, sink, swimming pool or shower.
- CAUTION:** Use only the internally, non-user replaceable battery fitted to the parent unit. There may be a risk of explosion if a wrong type of battery is used for the parent unit. The battery cannot be subjected to high or low extreme temperature and low air pressure at high altitude during use, storage or transportation. Disposal of batteries in fire or a hot oven, mechanically crushing or cutting the battery can result in an explosion. Subjecting products or batteries to an extremely high temperature environment can result in explosion or leakage of flammable liquids, or gas. Products or batteries subjected to extremely low air pressures may result in explosion or leakage of flammable liquids, or gas. Dispose of used batteries according to the information in **The EBRC seal**.
- Use only the power adapters supplied with this product. Incorrect power adapter polarity or voltage can seriously damage the product.

Power adapter information:
Baby Unit Output: 5V DC 1.5A
VTech Telecommunications Ltd.
Model: VT07EUS05150
-OR-
Jiangji Jian Aohai Technology Co., Ltd.
Model: A938-050150W-US1
Parent Unit Output: 5V DC 2A
VTech Telecommunications Ltd.
Model: VT07EUS05200
-OR-
Jiangji Jian Aohai Technology Co., Ltd.
Model: A938-050200W-US1

Rechargeable battery information:
3.7V 5000mAh, 18.5Wh Lithium-ion battery
Zhuhai Great Power Energy Co., Ltd.
Model: G5P806090-5Ah-3.7V-151P

- The power adapter is intended to be correctly oriented in a vertical or floor mount position. The prongs are not designed to hold the plug in place if it is plugged into a ceiling, under-the-table or cabinet outlet.
- For pluggable equipment, the socket-outlet (power adapter) should be installed near the equipment and should be easily accessible.
- Unplug this product from the wall outlet before cleaning. Do not use liquid or aerosol cleaners. Use a damp cloth for cleaning.
- Do not modify the power adapters or replace with other third-party adapters.
- Do not allow anything to rest on the power cords. Do not install this product where the cords may be walked on or damaged.
- The product should only be operated from a power source indicated on the power adapter label or marking. If you are unsure of the type of power supply in your home, consult your dealer or electricity supply provider.
- Do not overload wall outlets or use an extension cord.
- Do not place this product on an unstable table, shelf, stand or other unstable surfaces.
- This product should not be placed in any area where proper ventilation is not provided. Any slots or openings in the back or bottom of this product are provided for ventilation. To protect from overheating, openings must not be blocked

by placing the product on a soft surface such as a bed, sofa or rug. This product should never be placed near or over a radiator or heat source.

- Never insert any objects through any apertures or slots in the product as this can be dangerous and cause damage to the battery or other internal parts. Never spill any liquids on the product.
- To reduce the risk of electric shock, do not disassemble this product, but take it to an authorized service facility. Disassembling or removing parts of the product other than battery replacement via a battery door (if applicable) may expose dangerous voltages or other risks.
- You should test the sound reception every time you turn on the units or move one of the components.
- Periodically examine all components for damage.
- There is a very low risk of privacy loss when using certain electronic devices, such as baby monitors, cordless telephones, etc. To protect your privacy, make sure the product has never been used before purchase, reset the baby monitor periodically by powering off and then powering on the units, and power off the baby monitor if you are not intending to use it for some time.
- Children should be supervised to ensure that they do not play with the product.
- The small parts of this monitor can be swallowed by babies or small children. Keep these parts out of reach of children.
- The product is not intended for use by persons (including children) with reduced physical, sensory or mental capabilities, or lack of experience and knowledge, unless they have been given supervision or instruction concerning use of the appliance by a person responsible for their safety.

SAVE THESE INSTRUCTIONS

- Use and store the product at a temperature between 32°F (0°C) and 104°F (40°C).
- Mishandling batteries can cause burn, fire or explosion hazards.
- Batteries should not be exposed to excessive heat such as bright sunshine or fire.
- Do not expose the product to extreme cold, heat or direct sunlight. Do not place the product close to a heating source.

Warning—Strangulation Hazard—Children have STRANGLED in cords. Keep this cord out of the reach of children (more than 3 ft (0.9m) away). Do not remove warning label on the adapter cord.

- Never place the baby unit(s) inside the baby's crib or playpen. Never cover the baby unit(s) or parent unit with anything such as a towel or a blanket.
- Other electronic products can cause interference to your parent unit and baby unit. Try installing your baby unit as far away as possible from the following electronic devices: wireless routers, radios, mobile telephones, intercoms, room monitors, televisions, personal computers, kitchen appliances (e.g. microwave ovens) and cordless telephones.

Precautions for users of implanted cardiac pacemakers
Cardiac pacemakers (applies only to digital cordless devices):
Wireless Technology Research, LLC (WTR), an independent research entity, led a multidisciplinary evaluation of the interference between portable wireless devices and implanted cardiac pacemakers. Supported by the U.S. Food and Drug Administration, WTR recommends to physicians that:

- Pacemaker patients** should keep wireless devices at least six inches from the pacemaker.
- Should NOT place wireless devices directly over the pacemaker, such as in a breast pocket, when it is turned ON. WTR's evaluation did not identify any risk to bystanders with pacemakers from other persons using wireless devices.

Electromagnetic fields (EMF)
This VTech product complies with all standards regarding electromagnetic fields (EMF). If handled properly and according to the instructions in this user's manual, the product is safe to be used based on scientific evidence available today.

CONNECT, CHARGE AND POWER ON THE BABY MONITOR

1. Connect the parent unit and baby unit to the adapter and mains supply. The parent unit turns on automatically after connection to the power socket.

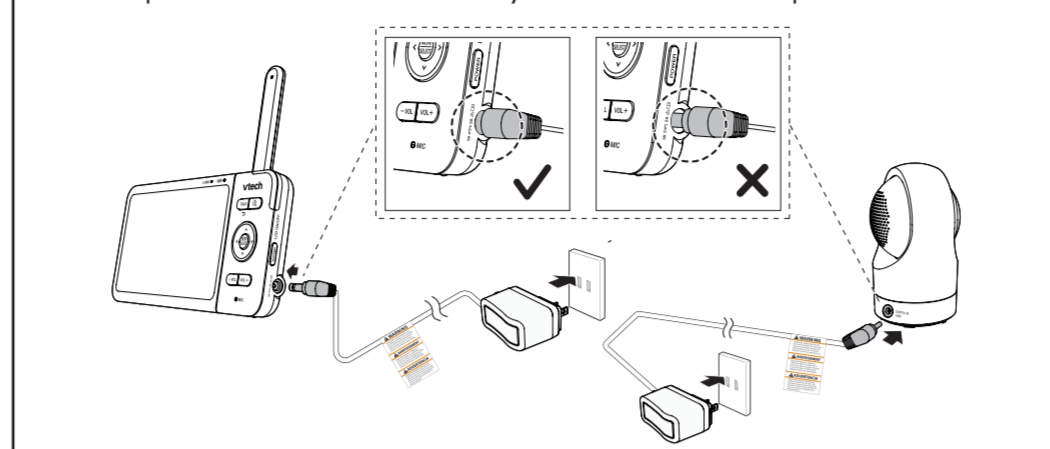

2. Slide the switch to ON to power on the baby unit.

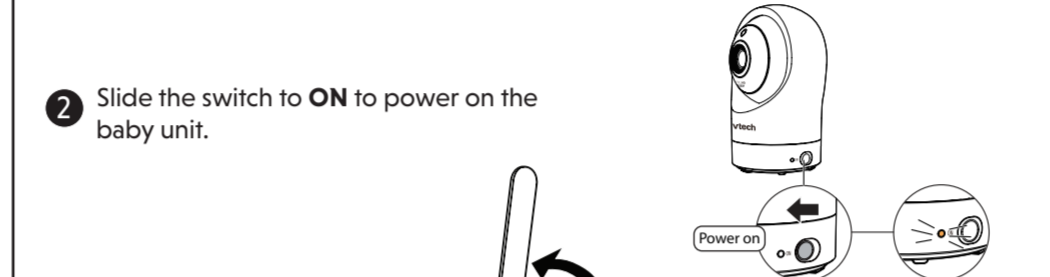

3. For optimum reception, always raise the parent unit antenna.

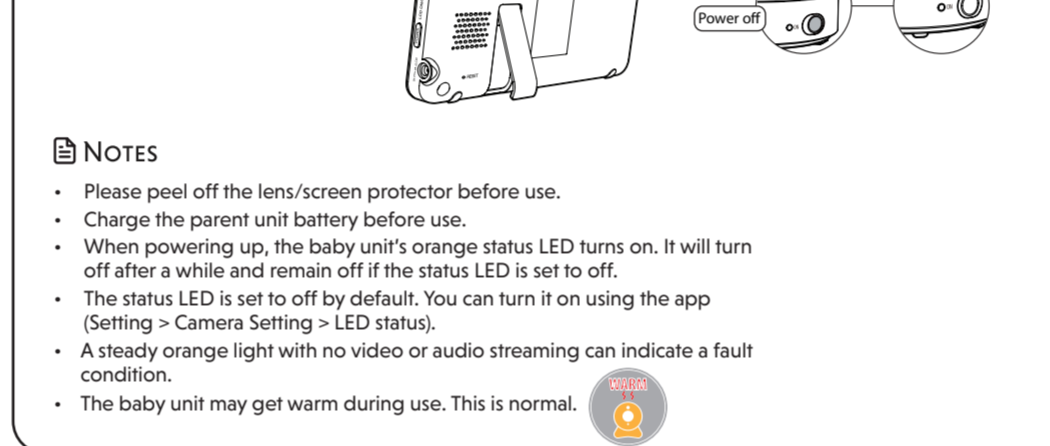

NOTES

- Please peel off the lens/screen protector before use.
- Charge the parent unit battery before use.
- When powering up, the baby unit's orange status LED turns on. It will turn off after a while and remain off if the status LED is set to off.
- The status LED is set to off by default. You can turn it on using the app (Setting > Camera Setting > LED status).
- A steady orange light with no video or audio streaming can indicate a fault condition.
- The baby unit may get warm during use. This is normal.

DOWNLOAD APP FOR MOBILE ACCESS

Use the **MyVTech Baby Plus** on your mobile device to monitor your baby remotely. Follow the instructions below to set up and pair your baby monitor with the app.

- Scan the QR code to download the free **MyVTech Baby Plus** mobile app, or search "MyVTech Baby Plus" on App Store or Google Play Store. If you have previously installed the app, ensure that you have the latest version.

NOTE

- Make sure your mobile device meets the minimum requirement for the mobile app.

Minimum requirement

- The mobile app is compatible with:
 - Android™ 9.0 or later (Not compatible with mobile devices with a 32-bit Android operating system); and
 - iOS 14 or later.

2. Tap to launch the mobile app on your device and create an account.

3. We recommend that you use common webmail services, such as Google Gmail, to register your user account. Check your email (including the Spam folder) and activate your new account by entering the email verification code. Then, sign in to your account.

4. Ensure that you are connected to a **2.4GHz Wi-Fi network** and have enabled **Bluetooth and Location Service** on your device.

5. After signing in to the app, select **Camera(s) with Parent unit** and scan the QR code displayed on the parent unit. To find the QR code, press the **MENU/SELECT** button and go to > **Connect to Mobile App**.

6. Input the Wi-Fi password from the app.

7. **Press and hold** the pair key on the baby unit for 3 seconds until you hear the beep sound to enter pairing mode.

8. Select the camera model that appears in the app and wait for the camera to connect. Once connected, it will display a live view preview.

9. Select **"Continue"** and create a profile for your baby (Optional). Now you can start monitoring! (For models with 2 cameras, a pop-up will ask if you wish connect another camera. Repeat steps 7-9 for the second camera.)

Tip

Use **Camera Sharing** to instantly share access to the camera. Follow these steps:

- Go to **Menu** and select **Camera Sharing**.
- Choose **"Invite People"** and enter the name and email address of the family member's app account.
- The family member will receive a pop-up notification in the app and can accept the invitation to access the camera(s).

HOW THE SYSTEM WORKS

Tip To receive product firmware updates, this baby monitor requires connecting to a **2.4GHz home Wi-Fi network**.

Direct mode
Your baby monitor parent unit and baby unit connect to each other in **Direct mode** by default, which allows you to immediately stream video out of the box.

Tip
You may experience reduced signal strength if your parent unit and baby unit are far apart, or there are obstructing factors, such as internal walls between them. Move the parent unit closer to the baby unit to improve the signal strength. Ensure the parent unit antenna is raised for optimum reception.



Wi-Fi mode
To enhance your experience and enjoy seamless live video streaming via your mobile app, and to receive product software updates (when available), we highly recommend setting up your monitor's Wi-Fi connection.

It uses your 2.4GHz home Wi-Fi network to connect your video monitor and supports live video streaming through the mobile app.



To stream live video remotely with your mobile device, download and install the **MyVTech Baby Plus** mobile app. With the mobile app, your Wi-Fi router (not included) provides Internet connectivity to your HD video monitor system. It serves as a communication channel between your baby unit and mobile device, allowing you to monitor and/or control your baby unit wherever you are. For more details, see **Download app for mobile access** section in this quick start guide.

CABLE MANAGEMENT

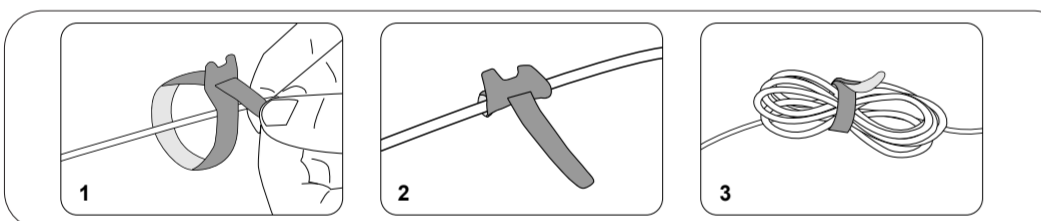

TECHNICAL SPECIFICATIONS

Frequency	Baby unit: 2402 - 2480 Mhz (Wi-Fi, FHSS, BLE) Max Transmit power is 10mW (Wi-Fi, FHSS, BLE)
	Parent unit: 2406 - 2475 Mhz Max Transmit power is 100mW
LCD	5" Color LCD (IPS 1280 x 720 pixels)
Nominal effective range	Maximum power allowed by FCC and IC. Actual operating range may vary according to environmental conditions at the time of use.
Power requirement	Baby unit power adapter: Output: 5V DC, 1.5A. Parent unit power adapter: Output: 5V DC, 2A. Parent unit battery: 3.7V 5000mAh, 18.5Wh Lithium-ion battery

DISCLAIMER AND LIMITATION OF LIABILITY

VTech Communications, Inc. and its suppliers assume no responsibility for any damage or loss resulting from the use of this user's manual. VTech Communications, Inc. and its suppliers assume no responsibility for any loss or claims by third parties that may arise through the use of this product. Company: VTech Communications, Inc.
Address: 9020 SW Washington Square Road - Ste 555 Tigard, OR 97223, United States
Phone: 1 (800) 595-9511 in the U.S. or 1 (800) 267-7377 in Canada

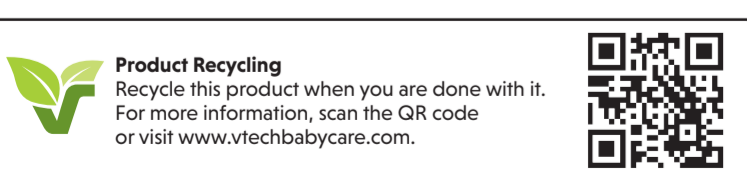

Android™ and Google Play™ are trademarks of Google Inc.
App Store is a trademark of Apple Inc., registered in the U.S. and other countries.
IOS is a trademark or registered trademark of Cisco in the U.S. and other countries and is used under license.

Specifications are subject to change without notice.
© 2025 VTech Communications, Inc.
All rights reserved. 02/25_RM5764HD_Gen 2_QSG_V2

OVERVIEW

Baby unit overview

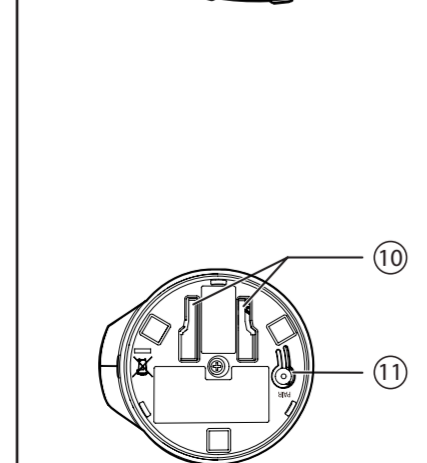
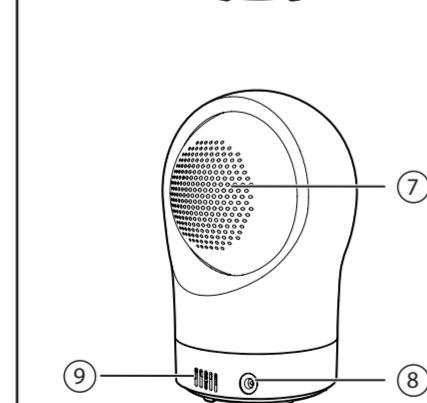
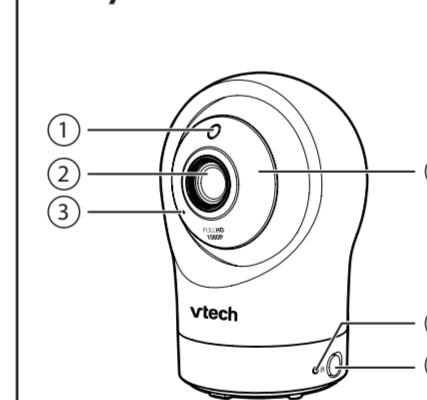

- Light sensor**
- Camera lens**
- Microphone**
- Infrared LEDs**
 - Allow you to see clearly in a dark environment.
- LED indicator**
 - Set to off by default. You can turn it on using the app (Setting > Camera Setting > LED status).
 - In direct mode:
 - Orange is steadily on when the baby unit is connecting to the parent unit.
 - Orange flashes slowly during video streaming.
 - In Wi-Fi mode:
 - Green is steadily on when the baby unit is connected to Wi-Fi.
 - Green flashes slowly during video streaming to Wi-Fi.
- ON/OFF switch**
- Speaker**
- Power jack**
- Temperature sensor**
- Wall mount slots**
- PAIR**
 - To enter pairing mode, **press and hold** the **PAIR** key for three seconds until you hear a beep sound. Then follow the app instructions to connect the camera to a 2.4GHz Wi-Fi network.
 - To reset the baby unit, **press and hold** the **PAIR** key until you hear a beep sound. Release the **PAIR** key, and then press it again five times until you hear another beep sound. The baby unit will emit another beep when the reset is complete. After that, the baby unit will reboot.

Parent unit overview

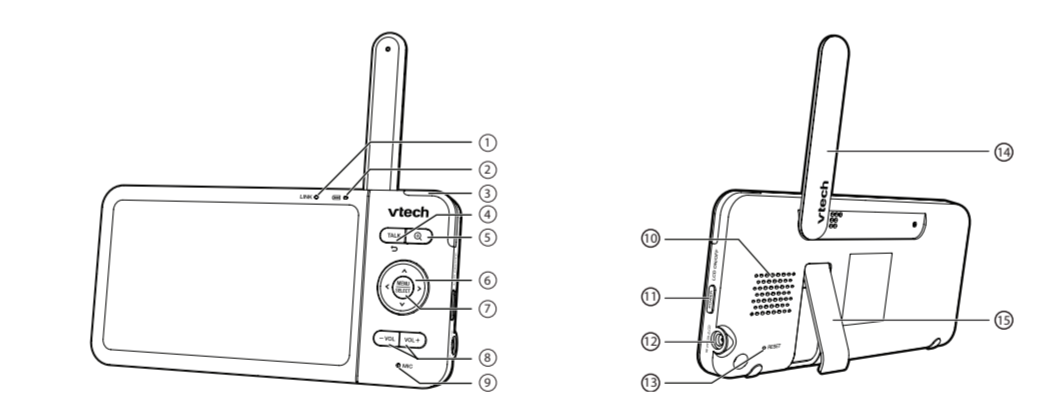

- LINK LED light**
 - On when the parent unit is linked to the baby unit.
 - Flashes when the link to the baby unit is lost.
- LINK LED light**
 - On when the parent unit is connected to AC power, and the battery is charging.
 - Flashes when the parent unit battery is low and needs to be charged.
- 3-level sound indicator light**
 - The lights indicate different sound levels detected from the baby unit.
 - Green light: low sound level.
 - Green and amber lights: moderate sound level.
 - Green, amber, and red lights: high sound level.
- TALK /**
 - Press and hold** to talk through the baby unit when displays on screen.
 - While in a sub-menu, press to exit.
- Zoom**
 - Press to zoom in/out** to different levels.
- Arrow keys**
 - Press to navigate leftward, upward, rightward or downward, within the main menu and submenus.
 - Press to move the baby unit camera leftward, rightward, upward or downward.
- MENU/SELECT**
 - Press to enter the main menu.
 - While in a menu, press to confirm a selection, or save a setting.
- VOL/ VOL+**
 - Increase, decrease or mute the parent unit volume.
- Microphone**
- Speaker**
- POWER / LCD ON/OFF**
- RESET**
 - Force reboot the parent unit.
- Antenna**
- Stand**

PARENT UNIT ICONS

Main Menu	Sub-menu	Options
	Monitoring mode (For RM5764-2HD only)	<ul style="list-style-type: none"> View baby units in Single mode. View baby units in Patrol mode (switch view every 10 seconds). View baby units in Split screen.
	Melodies and soothing sounds	<ul style="list-style-type: none"> Play/Stop <ul style="list-style-type: none"> Toggle between play and stop. Library <ul style="list-style-type: none"> Select to play all melodies, or play one of the five melodies or five soothing sounds. Camera Volume <ul style="list-style-type: none"> Adjusts baby unit speaker volume. Timer <ul style="list-style-type: none"> Set the timer to stop playing after 15, 30 or 60 minutes, or play non-stop.
	General settings	<ul style="list-style-type: none"> Connect to Mobile App <ul style="list-style-type: none"> Instructions for adding baby unit to mobile app. Camera Volume <ul style="list-style-type: none"> Adjusts baby unit speaker volume. Screen Brightness <ul style="list-style-type: none"> Adjusts parent unit screen brightness. Screen Off Timer <ul style="list-style-type: none"> Turn the screen off timer OFF, or set the screen to turn off after 1, 2 or 5 minutes when no sound is detected. Select AUTO to set the Sound Sensitivity level for the screen to auto turn on when a sound level is detected that is higher than the set level. The screen will turn off after 50 seconds of no sound detection.
	Alerts Settings	<ul style="list-style-type: none"> Adjusts the alert tone volume level. Motion Detect <ul style="list-style-type: none"> Turn the motion detection alert on/off. Adjust Motion Sensitivity level for waking the parent unit screen. Temperature <ul style="list-style-type: none"> Turn the temperature alert on/off. Select the temperature alert maximum and minimum temperature limits. Low Battery <ul style="list-style-type: none"> Toggle the low battery alert on or off. Lost Link <ul style="list-style-type: none"> Toggle the lost link alert on or off.
	Help and info	<ul style="list-style-type: none"> Help <ul style="list-style-type: none"> Support Information How-to Video <ul style="list-style-type: none"> Support video System Info <ul style="list-style-type: none"> System Information
	Status icons	<ul style="list-style-type: none"> Direct mode Parent unit and baby unit are connected to each other directly. Signal strength is indicated by the signal icon(s) on the right. The red bar(s) indicates no connection. Wi-Fi mode The signal icon(s) on the left indicate the baby unit is connected to a home Wi-Fi network. The red icon(s) indicates no connection. Baby unit 1 and 2 are being viewed in Patrol mode (For RM5764-2HD only). Baby unit 1 and 2 are being viewed in Split mode (For RM5764-2HD only).

PROTECT YOUR PRIVACY AND ONLINE SECURITY

VTech cares about your privacy and peace of mind. That's why we've put together a list of industry-recommended best practices to help keep your wireless connection private and your devices protected when online. We recommend you carefully review and consider complying with the following tips.

Ensure your wireless connection is secure.

- Before installing a device, ensure your router's wireless signal is encrypted by selecting the "WPA2-PSK with AES" setting in your router's wireless security menu.

Change default settings.

- Change your wireless router's default wireless network name (SSID) to something unique.
- Change default passwords to unique, strong passwords. A strong password:
 - Is at least 10 characters long.
 - Is complex.
 - Does not contain dictionary words or personal information.
 - Contains a mix of uppercase letters, lowercase letters, special characters and numbers.

Keep your devices up to date.

- Download security patches from manufacturers as soon as they become available. This will ensure you always have the latest security updates.
- If the feature is available, enable automatic updates for future releases.

Disable Universal Plug and Play (UPnP) on your router.

- UPnP enabled on a router can limit the effectiveness of your firewall by allowing other network devices to open inbound ports without any intervention or approval from you. A virus or other malware program could use this function to compromise security for the entire network.

For more information on wireless connections and protecting your data, please review the following resources from industry experts:

- Federal Communications Commission: Wireless Connections and Bluetooth Security Tips – www.fcc.gov/consumers/guides/how-protect-yourself-online.
- U.S. Department of Homeland Security: Before You Connect a New Computer to the Internet – www.us-cerr.gov/ncas/tips/ST15-003.
- Federal Trade Commission: Using IP Cameras Safely – <https://www.consumer.ftc.gov/articles/0382-using-ip-cameras-safely>.
- Wi-Fi Alliance: Discover Wi-Fi Security – <http://www.wi-fi.org/discover-wi-fi/security>.

Status icons	Status icons
Direct mode Parent unit and baby unit are connected to each other directly. Signal strength is indicated by the signal icon(s) on the right. The red bar(s) indicates no connection.	Night vision is turned on.
Wi-Fi mode The signal icon(s) on the left indicate the baby unit is connected to a home Wi-Fi network. The red icon(s) indicates no connection.	Motion detection alert is turned on.
Baby unit 1 and 2 are being viewed in Patrol mode (For RM5764-2HD only).	Melodies and soothing sounds are playing.
Baby unit 1 and 2 are being viewed in Split mode (For RM5764-2HD only).	Temperature alert is turned on.
	Parent unit is muted.
	Temperature measured at baby unit.
	Battery level indicator
	Low battery indicator

TEST THE SOUND LEVEL AND POSITION THE BABY MONITOR

Testing the sound level of the baby monitor

NOTE

- This baby monitor is intended as an aid. It is not a substitute for proper adult supervision, and should not be used as such.

CAUTION

- For hearing protection, make sure the parent unit is more than 10 feet away from the baby unit. If you hear any feedback noise from the parent unit, move the parent unit further until the noise stops. You can also press **VOL -** on the parent unit to lower or mute the noise.

TIP

- Increase the parent unit speaker volume if you cannot hear the sounds transmitted from the baby unit.

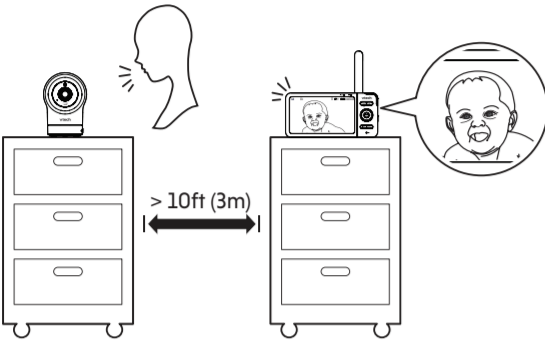

Positioning the baby monitor

CAUTION

- Keep the baby unit out of reach of your baby. Never place or mount the baby unit inside the baby's crib or playpen.

- Place the baby unit more than 3 feet away from your baby.
- Adjust the angle of the baby unit to aim the camera at your baby.

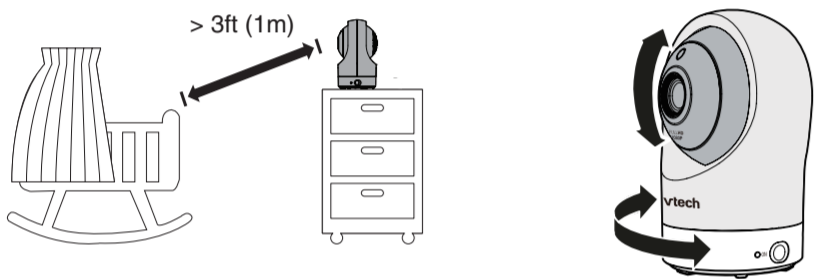

- To avoid causing feedback noise from your baby monitor:
 - Make sure your baby unit and parent unit are more than 10 feet apart; OR
 - Turn down the volume of your parent unit.

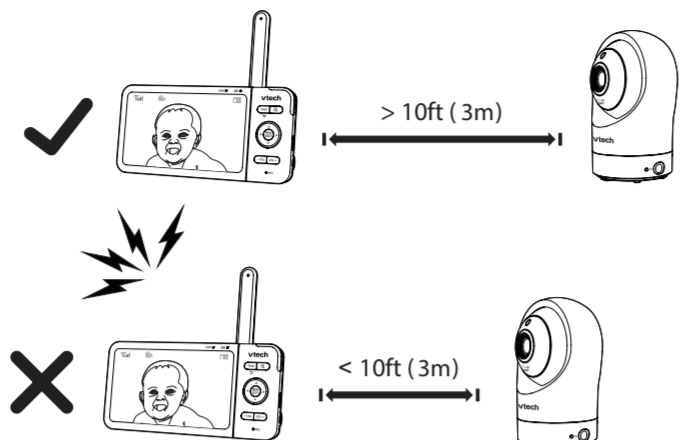

TEST THE LOCATION FOR THE BABY UNIT

If you plan to install your baby unit in a designated location, and use your home Wi-Fi network to connect your video monitor, you need to test which of your selected monitoring areas within the house have good Wi-Fi signal strength. After you have powered on your parent unit, you can use your parent unit's **Wi-Fi signal icon(s)** to assist in checking. Once you have identified the suitable location, you can install your baby unit. Adjust the distance between your baby unit and the Wi-Fi router if needed.

TIP

- Surroundings and obstructing factors, such as large metallic objects, filing cabinets, long distances, electrical appliances, and internal walls, may reduce Wi-Fi signal.

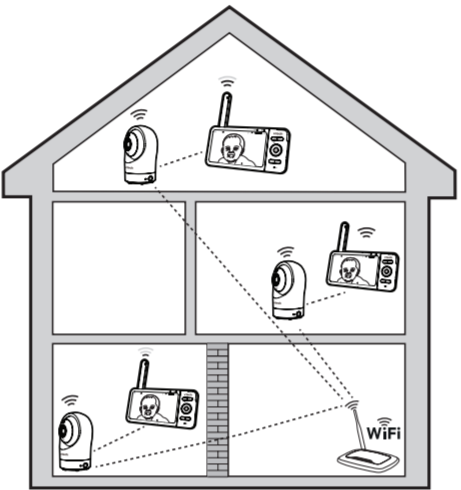

NIGHT VISION

The baby unit has infrared LEDs that allow you to see your baby clearly at night or in a dark room. When the baby unit detects low light levels, the infrared LEDs are switched on automatically. The images from the baby unit are in black and white, and  appears on the parent unit screen.

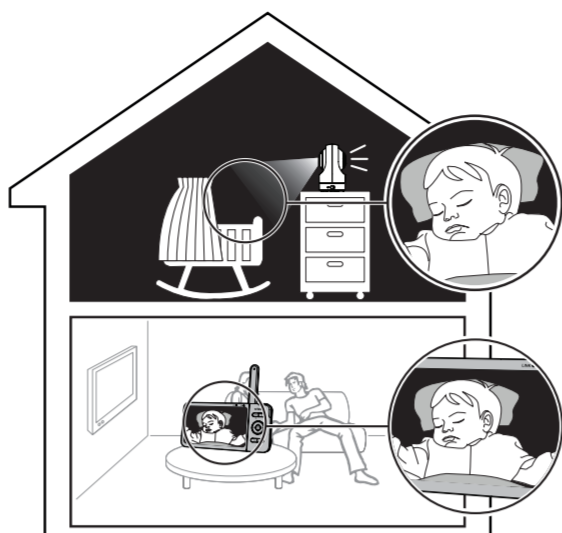

NOTES

- A **click sound** from the baby unit is a normal and occurs when your unit adapts to the environment lighting conditions.
- To achieve accurate and high quality video, your baby unit is equipped with an infrared cut-off filter lens that optimizes color accuracy in bright, day-time environments. When the environment turns dark at night, this filter lens is withdrawn to enhance night vision quality. The brief **click sound** you hear is from the filter lens activating/deactivating as the unit switches from day to night vision (and vice versa).

TIP

- Depending on the surroundings and other interfering factors, for example, lighting, objects, colors and backgrounds, the image quality may vary. Adjust the baby unit angle or place the baby unit at a higher location to prevent glare and a blurred display.

NEED HELP?

For instructions and guides to make the best use of your baby monitor, and for the latest information and support, check out our online help topics and FAQs. The online help page will also be updated periodically to reflect product system updates.

Use your smartphone or mobile device to access our online help.

- Go to <https://help.vtechphones.com/RM5764HD> or <https://help.vtechphones.com/RM5764-2HD>; OR
- Scan the QR code on the right. Launch the camera app or QR code scanner app on your smartphone or tablet. Hold the device's camera up to the QR code and frame it. Tap the notification to be redirected to the online help page.

- If the QR code is not clearly displayed, adjust your camera's focus by moving your device closer or further away until the image is clear.

If you would like to contact us, visit <https://help.vtechphones.com/cs>.

You can also call our Customer Support at 1 (800) 595-9511 [in US] or 1 (800) 267-7377 [in Canada] for help.



GENERAL PRODUCT CARE

To keep this product working well and looking good, follow these guidelines:

- Avoid placing near heating appliances and devices that generate electrical noise (for example, motors or fluorescent lamps).
- DO NOT expose to direct sunlight or moisture.
- Avoid dropping the product or treating it roughly.
- Clean with a soft damp cloth.
- DO NOT immerse the parent unit or the baby unit in water and do not clean under running water.
- DO NOT use solvents, household cleaning sprays, or liquid cleaners.
- Make sure the parent unit and the baby unit are dry before reconnecting to the mains supply.

STORAGE

When you are not going to use the video monitor for some time, store the parent unit, the baby unit and the adapters in a cool, dry place.

FREQUENTLY ASKED QUESTIONS

Below are the questions most frequently asked about the video monitor.

Can I turn the parent unit display screen off but keep hearing sounds from the baby unit?	Yes, press POWER LCD ON/OFF on the parent unit to turn off the screen. Press any key to turn the screen back on.
Why is the baby unit not responding normally?	Try the following (in the order listed) for a common cure: <ol style="list-style-type: none">Disconnect the power to the baby unit.Wait a few minutes before connecting power back to the baby unit.Reboot/Reset the parent unit.
Why is my screen in black and white?	The baby unit has a light sensor that measures ambient light. When the ambient light is dim, such as during night time or in a dark room, the baby unit activates its infrared LEDs, and displays the camera images in black and white night vision.
Why does my baby unit show offline? Why is the connection lost every now and then?	The baby unit may have lost connection to the Wi-Fi router. Check your network and router settings. Other electronic products may cause interference with your baby unit. Try installing your baby unit as far away from these electronic devices as possible.
Why can't I hear a sound/Why can't I hear my baby crying?	The parent unit speaker volume may be too low. Press VOL + on the parent unit to increase the volume.

THE RBRC SEAL



The RBRC seal on the lithium-ion battery indicates that VTech Communications, Inc. is voluntarily participating in an industry program to collect and recycle these batteries at the end of their useful lives, when taken out of service within the United States and Canada. The program provides a convenient alternative to placing used lithium-ion batteries into the trash or municipal waste, which may be illegal in your area.

VTech's participation makes it easy for you to drop off the spent product at local retailers participating in the program or at authorized VTech product service centers. Please call **1 (800) 8 BATTERY** for information on Li-ion battery recycling and disposal bans/restrictions in your area. VTech's involvement in this program is part of its commitment to protecting our environment and conserving natural resources.

The **RBRC Seal and 1 (800) 8 BATTERY** are registered trademarks of Call2Recycle, Inc.

FCC AND IC REGULATIONS

FCC Part 15

NOTE: This equipment has been tested and found to comply with the requirements for a Class B digital device under Part 15 of the Federal Communications Commission (FCC) rules. These requirements are intended to provide reasonable protection against harmful interference in a residential installation. This equipment generates, uses and can radiate radio frequency energy and, if not installed and used in accordance with the instructions, may cause harmful interference to radio communications. However, there is no guarantee that interference will not occur in a particular installation. If this equipment does cause harmful interference to radio or television reception, which can be determined by turning the equipment off and on, the user is encouraged to try to correct the interference by one or more of the following measures:

- Reorient or relocate the receiving antenna.
- Increase the separation between the equipment and receiver.
- Connect the equipment into an outlet on a circuit different from that to which the receiver is connected.
- Consult the dealer or an experienced radio/TV technician for help.

WARNING: Changes or modifications to this equipment not expressly approved by the party responsible for compliance could void the user's authority to operate the equipment.

This device complies with Part 15 of the FCC rules. Operation is subject to the following two conditions: (1) this device may not cause harmful interference, and (2) this device must accept any interference received, including interference that may cause undesired operation.

To ensure safety of users, the FCC has established criteria for the amount of radio frequency energy that can be safely absorbed by a user or bystander according to the intended usage of the product. This product has been tested and found to comply with the FCC criteria. The baby unit shall be installed and used such that parts of all persons' body are maintained at a distance of approximately 8 in (20 cm) or more. The transmitter and antenna of the parent unit shall be held at least 1 in (2.5 cm) from your face.

This Class B digital apparatus complies with Canadian requirement: CAN ICES-3 (B)/NMB-3(B)

Industry Canada

This device contains licence-exempt transmitter(s)/receiver(s) that comply with Innovation, Science and Economic Development Canada's licence-exempt RSS(s). Operation is subject to the following two conditions: (1) This device may not cause interference. (2) This device must accept any interference, including interference that may cause undesired operation of the device.

The term "IC" before the certification/registration number only signifies that the Industry Canada technical specifications were met. This product meets the applicable Innovation, Science and Economic Development Canada technical specifications.

RF radiation exposure statement

The product complies with FCC RF radiation exposure limits set forth for an uncontrolled environment. The baby unit should be installed and operated with a minimum distance of 8 in (20 cm) between the baby unit and all persons' body. Use of other accessories may not ensure compliance with FCC RF exposure guidelines. This equipment complies also with Industry Canada RSS-302 with respect to Canada's Health Code 6 for Exposure of Humans to RF Fields.

CALIFORNIA ENERGY COMMISSION BATTERY CHARGING TESTING MODE

This video monitor meets the California Energy Commission (CEC) regulations for energy consumption. Your video monitor is set up to comply with the energy-conserving standards right out of the box.
The battery charging testing mode is activated while charging. Follow the instructions to install and charge the battery. The CEC battery charging testing mode is activated while it is powered off and charging. Even if the parent unit is paired to camera units, the CEC battery charging testing mode is activated while it is powered off and charging.

FOR CETL COMPLIANCE ONLY

La plaque signalétique appliquée est située au bas du socle de l'unité du bébé.
Lorsque vous utilisez votre appareil, vous devriez toujours suivre certaines mesures de précaution de base afin de réduire les risques d'incendie, d'électrocution et de blessures corporelles, dont ceux qui suivent:

- Observez toutes les instructions et mises en garde inscrites sur l'appareil.
- MISE EN GARDE:** N'installez pas l'unité du bébé à une hauteur supérieure à 2 mètres.
- Ce produit a été conçu pour être un dispositif d'appoint seulement. Il n'est pas le remplacement d'une supervision responsable et adéquate par un adulte et ne devrait pas être utilisé comme telle.
- Ce produit n'est pas conçu pour être utilisé en tant que moniteur médical.
- N'utilisez pas cet appareil près de l'eau ni de toute autre source d'humidité, par exemple, près d'une baignoire, cuve à lessive, évier de cuisine, dans un sous-sol humide ni près d'une piscine, dans un sous-sol humide ou une douche.
- MISE EN GARDE:** N'utilisez que la pile fournie. Il peut y avoir un risque d'explosion si un mauvais type de pile est utilisé pour le dispositif appaisant. La pile ne peut pas être soumise à des températures extrêmes élevées ou basses ou à une faible pression atmosphérique, à haute altitude pendant son utilisation, son entreposage ou son transport. Le fait de jeter la pile dans au feu ou dans un feu chaud, ou d'écraser ou de couper mécaniquement la pile peut entraîner une explosion. Le fait de laisser la pile dans un environnement à température extrêmement élevée peut entraîner une explosion ou une fuite de liquide ou de gaz inflammable. Une pile soumise à une pression d'air extrêmement basse peut provoquer une explosion ou une fuite de liquide ou de gaz inflammable. Mettez au rebut la pile usagée conformément aux informations figurant dans la section **Le recyclage RBRC**.
- N'utilisez que les adaptateurs inclus avec ce produit. L'utilisation d'un adaptateur dont la polarité ou la tension serait inadéquate risque d'endommager sérieusement le produit et mettre votre sécurité en péril.

Informations sur les adaptateurs électriques :
Sortie: 5 V CC 1,5A
VTECH Telecommunications Ltd. Modèle: V70TEUS05150
-Ou-
Jian Ashal Technology Co., Ltd.
Modèle: AP98-050150W-U51
Sortie: 5 V CC 2A
VTECH Telecommunications Ltd. Modèle: V70TEUS05200
-Ou-
Jian Ashal Technology Co., Ltd.
Modèle: AP98-050200W-U51

Informations sur les piles rechargeables :
3,7V 5000mAh, 18,5Wh Lithium-ion batterie
Zhuhai Great Power Energy Co., Ltd.
Modèle: GP80690-3A-3,7V-L31P
Lorsqu'ils sont branchés dans une prise de courant, les adaptateurs sont conçus pour être utilisés avec le type d'alimentation indiqué sur l'étiquette. Les broches n'ont pas été conçues pour supporter le poids du bloc d'alimentation et le maintenir en place si celui-ci est branché dans une prise au plafond, sous une table ou dans un meuble.

- Pour les appareils raccordés, la prise de courant et l'adaptateur secteur) doit être installée près de l'équipement et doit être facilement accessible.
- Débranchez ce produit de la prise de courant avant de procéder au nettoyage. N'utilisez pas de nettoyeurs à vapeur. Utilisez un chiffon humide pour le nettoyer.
- Ne coupez pas les cordons d'alimentation pour remplacer les fiches, car ceci peut présenter un danger potentiel.
- Ne laissez aucun objet reposer ni appuyer sur le cordon d'alimentation. N'installez pas cet appareil dans un endroit où on risque d'écraser le cordon d'alimentation ou de le piétiner.
- Ne faites fonctionner cet appareil qu'avec le type d'alimentation indiqué sur l'étiquette. Si vous ne connaissez pas le type d'alimentation que vous possédez ou votre domicile, consultez votre marchand ou votre compagnie locale d'électricité.
- L'identification doit être fournie à partir d'un acquiescement gauche (le symbole USB aux conditions de la source d'énergie limitée).
- Ne surchargez pas les prises de courant marquées ni les rallonges électriques.
- Ne placez pas cet appareil sur un chariot, meuble, trépied, support de montage ni table chancelante.
- Les trous et ouvertures du boîtier, situés à l'arrière de l'appareil ou sous celui-ci, servent à aérer l'appareil. Pour l'empêcher de surchauffer, ne bloquez sous aucun prétexte ces ouvertures et n'empêchez pas l'aération adéquate de l'appareil en le plaçant sur un lit, divan, tapis ou toute autre surface similaire. De même, ne le positionnez pas à proximité ni au-dessus d'une source de chaleur ou d'un calorifère. De plus, ne placez pas l'appareil dans un endroit avant de vous assurer qu'il y ait une bonne circulation d'air.
- N'enfoncez jamais d'objets à travers les ouvertures de cet appareil, car ils pourraient entrer en contact avec des points de tension dangereux ou causer des courts-circuits qui peuvent dégénérer en incendies ou en risques d'électrocution. Ne renversez jamais de liquide dans ce produit.
- Afin de réduire les risques d'électrocution, ne démontez pas cet appareil, mais apportez-le dans un centre de service autorisé.
- Couverture du boîtier ou le retrait de toutes pièces que contient cet appareil, à l'exception de l'accès autorisé à certaines parties ou ouvertures, risque de vous exposer à des points de tension dangereux ou d'autres dangers. Un remontage incorrect peut par la suite présenter des risques d'électrocution.
- Vous devriez tester la réception chaque fois que vous mettez l'appareil en fonction.
- Examinez les composants afin de vérifier si celles-ci ne sont pas endommagées.
- Il existe un très faible risque de perte de confidentialité avec certains appareils électroniques (autres écoute-bébé, téléphones sans fil, etc.). Pour éviter, assurez que le produit n'a jamais été utilisé avant l'achat, réinitialiser l'unité de façon périodique, éteindre l'écoute-bébé quand il n'est pas en cours d'utilisation, à haute altitude pendant son utilisation, son entreposage ou son transport. Le fait de jeter la pile dans au feu ou dans un feu chaud, ou d'écraser ou de couper mécaniquement la pile peut entraîner une explosion. Le fait de laisser la pile dans un environnement à température extrêmement élevée peut entraîner une explosion ou une fuite de liquide ou de gaz inflammable. Une pile soumise à une pression d'air extrêmement basse peut provoquer une explosion ou une fuite de liquide ou de gaz inflammable. Mettez au rebut la pile usagée conformément aux informations figurant dans la section **Le recyclage RBRC**.
- N'utilisez que les adaptateurs inclus avec ce produit. L'utilisation d'un adaptateur dont la polarité ou la tension serait inadéquate risque d'endommager sérieusement le produit et mettre votre sécurité en péril.

CONSERVEZ CES INSTRUCTIONS

Mises en garde

- Utilisez et entreposez le produit à une température entre 0 °C (32 °F) et 40 °C (104 °F).
- Risque de brûlure, risque d'incendie, risque d'association à une mauvaise manipulation de la batterie.
- N'exposez pas cet appareil à des froids ou des chocs extrêmes, ainsi qu'à la lumière directe du soleil. Ne l'installez pas près d'une source de chauffage.

Avertissement - Risque de strangulation - Les enfants se sont ÉTRANGLÉS dans des cordons. Gardez ce cordon hors de portée des enfants (à plus de 0,9 m). N'enlevez pas cette étiquette.

Ne jamais placer le moniteur à l'intérieur du berceau ou du parc de bébé. Ne jamais couvrir le moniteur ou l'unité(s) portative avec un article tel une serviette ou une couverture.

D'autres produits électroniques peuvent causer des interférences après de votre caméra IP. Essayez d'installer votre caméra IP le plus loin possible de ces dispositifs électroniques: routeurs sans fil, radios, téléphones cellulaires, interphones, moniteurs de vidéos, téléviseurs, ordinateurs personnels, appareils électriques de cuisine et autres appareils électroniques.

Stimulateurs cardiaques implantés dans l'organisme
Les stimulateurs cardiaques ne s'applique qu'aux dispositifs numériques sans fil:

Débranchez ce produit de la prise de courant avant de procéder au nettoyage. N'utilisez pas de nettoyeurs à vapeur. Utilisez un chiffon humide pour le nettoyer.

Ne coupez pas les cordons d'alimentation pour remplacer les fiches, car ceci peut présenter un danger potentiel.

Ne laissez aucun objet reposer ni appuyer sur le cordon d'alimentation. N'installez pas cet appareil dans un endroit où on risque d'écraser le cordon d'alimentation ou de le piétiner.

MOUNT THE BABY UNIT (OPTIONAL)

NOTES

Check the reception strength and baby unit camera angle before drilling any holes:

- The types of screws and anchors you need depend on the composition of the wall. You may need to purchase the screws and anchors separately to mount your baby units.

- Place the wall mount bracket on a wall and then use a pencil to mark two holes in parallel. Remove the wall mount bracket and drill two holes in the wall (7/32 inch drill bit).

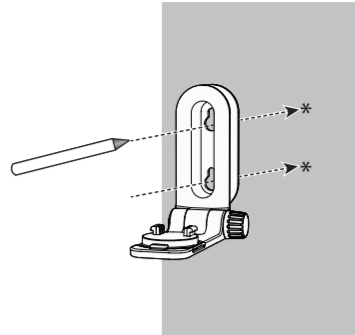

- If you drill the holes into a stud, go to step 3.
 - If you drill the holes into an object other than a stud, insert the anchors into the holes. Tap gently on the ends with a hammer until the anchors are flush with the wall.



- Align the wall mount bracket and screws with the holes in the wall as shown. Tighten the screw in the middle hole first, so that the wall mount bracket position is fixed. You can tighten the other screw in the top hole.

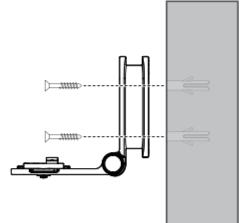

- Place the baby unit on the wall mount bracket, and then slide it forward until it locks into place. Connect the power adapter to the baby unit and a power supply.

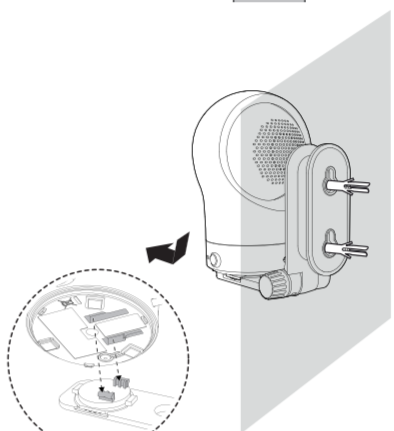

OR

- Insert the screws into the holes and tighten the screws until only 1/4 inch of the screws are exposed.

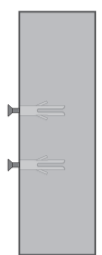

- Place the baby unit on the wall mount bracket, and then slide it forward until it locks into place. Align the holes on the wall mount bracket with the screws on the wall, and slide the wall mount bracket down until it locks into place.

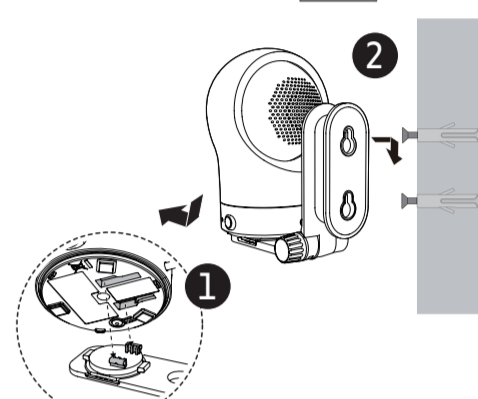

- You can maximize your baby unit viewing angle by tilting the wall mount bracket.

Hold the baby unit, and then rotate the knob in an anticlockwise direction. This will loosen the joint of the wall mount bracket. Tilt your baby unit up or down to adjust to your preferred angle. Then, rotate the knob in a clockwise direction to tighten the joint and secure the angle.

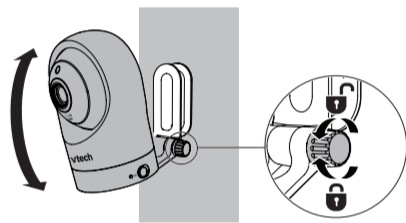

LIMITED WARRANTY

What does this limited warranty cover?

The manufacturer of this VTech Product warrants to the holder of a valid proof of purchase ("Consumer" or "you") that the Product and all accessories provided in the sales package ("Product") are free from defects in material and workmanship, pursuant to the following terms and conditions, when installed and used normally and in accordance with the Product operating instructions. This limited warranty extends only to the Consumer for Products purchased and used in the United States of America and Canada.

What will VTech do if the Product is not free from defects in materials and workmanship during the limited warranty period ("Material Defective Product")?

During the limited warranty period, VTech's authorized service representative will replace at VTech's option, without charge, a Materially Defective Product. If we choose to replace the Product, we may replace it with a new or refurbished Product of the same or similar design. We will retain defective parts, modules, or equipment. Replacement of the Product, at VTech's option, is your exclusive remedy. VTech will return the replacement Products to you in working condition. You should expect the replacement to take approximately 30 days.

How long is the limited warranty period?

The limited warranty period for the Product extends for ONE (1) YEAR from the date of purchase (90 days on products purchased as Refurbished[®]). This limited warranty also applies to the replacement product for a period of either (a) 90 days from the date the replacement Product is shipped to you or (b) the time remaining on the original one-year warranty (90-day limited warranty on products that are purchased as Refurbished[®]); whichever is longer.

*Refurbished products purchased from our online store carry a 90-day replacement warranty.

What is not covered by this limited warranty?

This limited warranty does not cover:

- Product that has been subjected to misuse, accident, shipping or other physical damage, improper installation, abnormal operation or handling, neglect, inundation, fire, water or other liquid intrusion; or
- Product that has been damaged due to repair, alteration or modification by anyone other than an authorized service representative of VTech; or
- Product to the extent that the problem experienced is caused by signal conditions, network reliability, or cable or antenna systems; or
- Product to the extent that the problem is caused by use with non-VTech accessories; or
- Product whose warranty/quality stickers, product serial number plates or electronic serial numbers have been removed, altered or rendered illegible; or
- Product purchased, used, serviced, or shipped for repair from outside the United States of America or Canada, or used for commercial or institutional purposes (including but not limited to Products used for rental purposes); or
- Product returned without a valid proof of purchase (see item 2 below); or
- Charges for installation or set up, adjustment of customer controls, and installation or repair of systems outside the unit.

How do you get warranty service?

To obtain warranty service in the USA, please visit our website at www.vtechbabycare.com or call 1 (800) 595-9511. In Canada, go to www.vtechcanada.com or call 1 (800) 267-7377.

NOTE: Before calling for service, please review the user's manual - a check of the Product's controls and features may save you a service call.

Except as provided by applicable law, you assume the risk of loss or damage during transit and transportation and are responsible for delivery or handling charges incurred in the transport of the Product(s) to the service location. VTech will return replaced Product under this limited warranty. Transportation, delivery or handling charges are prepaid. VTech assumes no risk for damage or loss of the Product in transit.

What must you return with the Product to get warranty service?

- Return the entire original package and contents including the Product to the VTech service location along with a description of the malfunction or difficulty; and
- Include a "valid proof of purchase" (sales receipt) identifying the Product purchased (Product model) and the date of purchase or receipt; and
- Provide your name, complete and correct mailing address, and telephone number.

Other limitations

This warranty is the complete and exclusive agreement between you and VTech. It supersedes all other written or oral communications related to this Product. VTech provides no other warranties for this Product. The warranty exclusively describes all of VTech's responsibilities regarding the Product. There are no other express warranties. No one is authorized to make modifications to this limited warranty and you should not rely on any such modification. State/Provincial Law Rights: This warranty gives you specific legal rights, and you may also have other rights, which vary from state to state or province to province.

Limitations: Implied warranties, including those of fitness for a particular purpose and merchantability (an unwritten warranty that the Product is fit for ordinary use) are limited to one year from the date of purchase. Some states/provinces do not allow limitations on how long an implied warranty lasts, so the above limitation may not apply to you. In no event shall VTech be liable for any indirect, special, incidental, consequential, or similar damages (including, but not limited to lost profits or revenue, inability to use the Product or other associated equipment, the cost of substitute equipment, and claims by third parties) resulting from the use of this Product. Some states/provinces do not allow the exclusion or limitation of incidental or consequential damages, so the above limitation or exclusion may not apply to you.

Please retain your original sales receipt as proof of purchase.