

tineco

Instruction Manual

Stick Vacuum Cleaner
A11 SERIES

BC

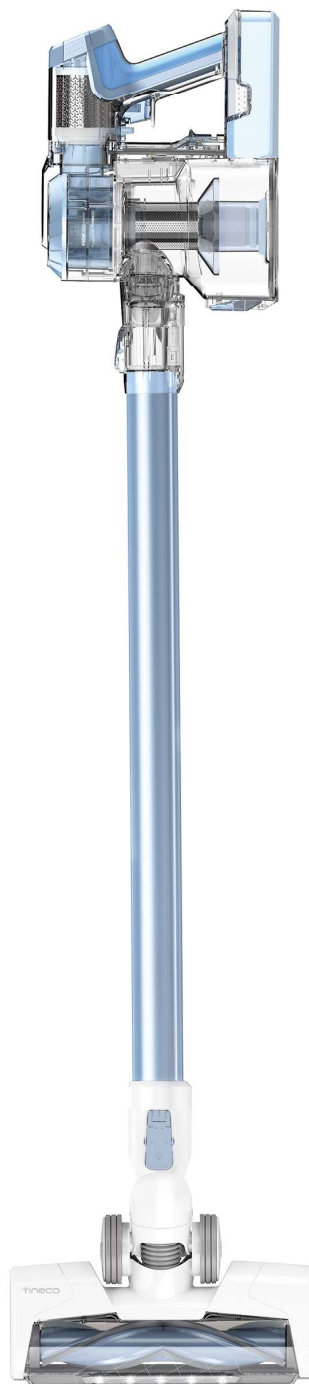

CONTENTS

1. Important Safety Instructions	01
2. Overview	03
3. Product Components	04
4. Accessory Instructions	05
5. Assembly	07
6. Product Operation	09
7. Daily Maintenance	12
8. Specification	14
9. Trouble Shooting	15
10. Warranty	16

Important Safety Instructions

SAVE THESE INSTRUCTIONS

Household use only.

When using an electrical appliance, basic precautions should always be followed, including the following:

READ ALL INSTRUCTIONS BEFORE USING (THIS APPLIANCE), Failure to follow the warnings and instructions may result in electric shock, fire and/or serious injury.

WARNING –To reduce the risk of fire, electric shock, or injury:

1. This appliance can be used by children aged from 8 years and above and persons with reduced physical, sensory or mental capabilities or lack of experience and knowledge if they have been given supervision or instruction concerning use of the appliance in a safe way and understand the hazards involved. Children shall not play with the appliance. Cleaning and user maintenance shall not be made by children without supervision.
2. The appliance is not to be used by persons (including children) with reduced physical, sensory or mental capabilities, or lack of experience and knowledge, unless they have been given supervision or instruction. Children being supervised not to play with the appliance, the appliance is only to be used with the unit provided.
3. Do not use outdoors or on wet surfaces.
4. Do not allow to be used as a toy. Close attention is necessary when used by or near children, pets or plants.
5. Use only as described in this manual. Use only manufacturer's recommended attachments.
6. Do not use with damaged cord or plug. If appliance is not working as it should, has been dropped, damaged, left outdoors, or dropped into water, return it to a service center.
7. Do not handle charger, including charger plug, and charger terminals with wet hands.
8. Do not put any object into openings. Do not use with any opening blocked; keep free of dust, lint, hair, and anything that may reduce air flow.
9. Keep hair, loose clothing, fingers, and all parts of body away from opening and moving parts.
10. Use extra care when cleaning on stairs.
11. Do not use to pick up flammable or combustible liquids, such as gasoline, or use in areas where they may be present.
12. Do not pick up anything that is burning or smoking, such as cigarettes, matches, or hot ashes.





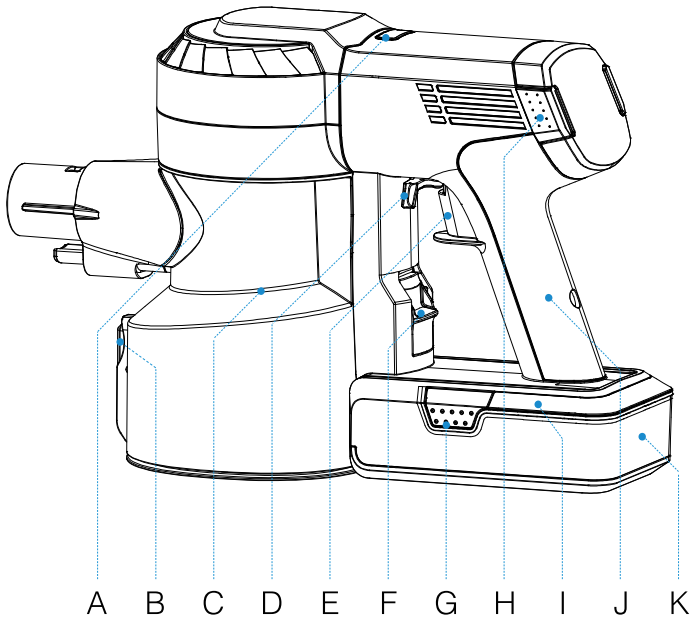





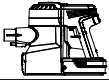



13. Do not use without filter.
14. Prevent unintentional starting. Ensure the switch is in the off position before connecting to battery pack, picking up or carrying the appliance. Carrying the appliance with your finger on the switch or energizing appliance that have the switch on invites accidents.
15. Disconnect the battery pack from the appliance before making any adjustments, changing accessories, or storing appliance. Such preventive safety measures reduce the risk of starting the appliance accidentally.
16. For the purposes of recharging the battery, only use the detachable supply unit provided with this appliance. A charger that is suitable for one type of battery pack may create a risk of fire when used with another battery pack.
17. Use appliances only with specifically designated TINECO battery packs. Use of any other battery packs may create a risk of injury and fire.
18. When battery pack is not in use, keep it away from other metal objects, like paper clips, coins, keys, nails, screws or other small metal objects, that can make a connection from one terminal to another. Shorting the battery terminals together may cause burns or a fire.
19. Under abusive conditions, liquid may be ejected from the battery; avoid contact. If contact accidentally occurs, flush with water. If liquid contacts eyes, additionally seek medical help. Liquid ejected from the battery may cause irritation or burns.
20. Do not use a battery pack or appliance that is damaged or modified. Damaged or modified batteries may exhibit unpredictable behavior resulting in fire, explosion or risk of injury.
21. Do not expose a battery pack or appliance to fire or excessive temperature. Exposure to fire or temperature above 266°F (130°C) may cause explosion.
22. Follow all charging instructions and do not charge the battery pack or appliance outside of the temperature range specified in the instructions. Charging improperly or at temperatures outside of the specified range may damage the battery and increase the risk of fire.
23. Have servicing performed by a qualified repair person using only identical replacement parts. This will ensure that the safety of the product is maintained.
24. This appliance contains battery cells that are non-replaceable. Do not modify or attempt to repair the appliance or the battery pack except as indicated in the instructions for use and care.
25. Always turn off this appliance before connecting or disconnecting motorized nozzle.
26. Do not charge or store the appliance outdoors or inside the car. Only charge, store or use the battery in a dry indoor area where the temperature is higher than 39.2°F (4°C) but lower than 104°F (40°C). The charger is for indoor use only.

Overview

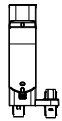

- A. MAX mode
- B. Dust empty release button
- C. Dustbin
- D. Switch lock
- E. Switch button
- F. Dustbin release button
- G. Battery release button
- H. HEPA release button
- I. Indicator light
- J. Rubber handle
- K. Battery pack

Product Components

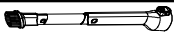
	Item	A11 HERO	A11 MASTER
	Main body	<input type="radio"/>	<input type="radio"/>
	Tube	<input type="radio"/>	<input type="radio"/>
	Full-size LED Multi-tasker Power Brush	<input type="radio"/>	<input type="radio"/>
	Mini power brush	<input type="radio"/>	<input type="radio"/>
	2-in-1 Dusting brush	<input type="radio"/>	<input type="radio"/>
	Crevice tool	<input type="radio"/>	<input type="radio"/>
	Full-size LED Soft-roller Power Brush	<input type="radio"/>	<input type="radio"/>
	Extra lithium battery	<input type="radio"/>	<input type="radio"/>
	Wall-mounted dock	<input type="radio"/>	<input type="radio"/>
	Adaptor	<input type="radio"/>	<input type="radio"/>
	Pre filter cleaning tool & extra pre filter	<input type="radio"/>	<input type="radio"/>
	Hair cleaning tool	<input type="radio"/>	<input type="radio"/>
	Flexible extension hose	<input type="radio"/>	<input type="radio"/>
	Soft dusting brush	<input type="radio"/>	<input type="radio"/>
	Multi-angle folding tube	<input type="radio"/>	<input type="radio"/>
	Flexible long crevice tool	<input type="radio"/>	<input type="radio"/>

***Actual accessories may vary from shown or change without notice.**

Available accessories may vary by market.

Accessory Instructions

Note:

- Test an inconspicuous area of a sensitive surface before using an accessory on it.
- All accessories can be directly connected to the main body or to the tube.

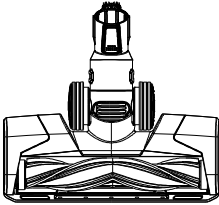

Full-size LED Multi-tasker Power Brush

Ideal for both hard floors and carpets.



Mini power brush

For vacuuming upholstered furniture, mattresses etc.

Vacuums pet hair and removes ingrained dirt.

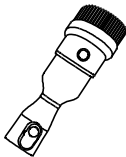

2-in-1 Dusting brush

Composed of a wide and a soft brush, and is able to switch from wide brush to soft brush by pressing the release button.

The soft brush is for hard surface furniture and the wide brush to vacuum upholstered furniture, curtain, etc.

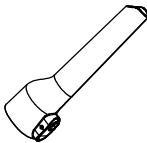

Crevice tool

For corners, niches and other hard-to-reach places, such as car seat and mat, picture frame, etc.

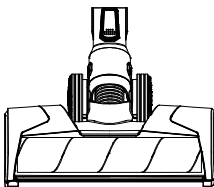

Full-size LED Soft-roller Power Brush

Perfect for hard floors, especially sensitive wood floor.

Vacuum coarse and fine dirt at the same time.

Accessory Instructions

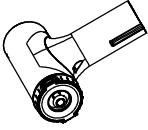

Pre filter cleaning tool

Dirty filter is a main cause of suction loss, this tool is designed for a deeper & easier cleaning solution with no suction loss. Put inside the dirty pre-filter and connect to the main body. Activate the appliance on MAX mode, and rotate the side cover. (See Daily Maintenance)



Hair cleaning tool

Use the end with small blade to remove the hair and debris wrapped around the roller. Use the end with little brush to clean the brush window, also can be used to clean the dustbin.

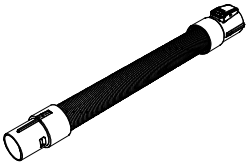

Flexible extension hose

Excellent extension and flexibility to get into hard-to-reach spaces, great for in-car usage. Use with above accessories, except motorized brush.



Soft dusting brush

Angled bristles on slender, oval shape provide anti-static cushioned contact. Suitable for dusting shelves, lighting, delicate surfaces, electronics, and more.

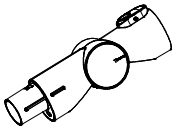

Multi-angle folding tube

One articulated joint makes it adjustable, clean from high to low place with flexibility.

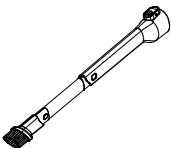

Flexible long crevice tool

Easy to bend, easily gets into the tight spots. Suitable for cleaning dust beneath furniture, along side the refrigerator, tight space behind sofa, and more.

Assembly

Install the Tube

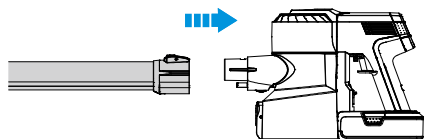

Insert tube.

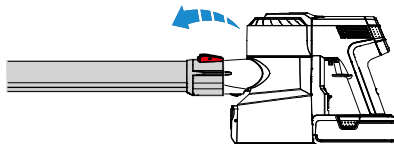

Press the release button and remove tube.

Install the Brush

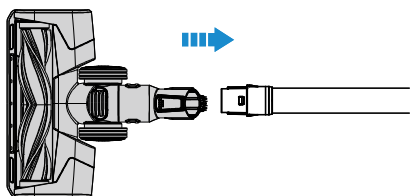

Insert motorized power brush.

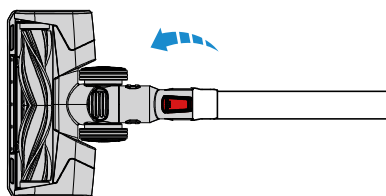

Press the release button and remove motorized power brush.

Assembly

Install the Dustbin

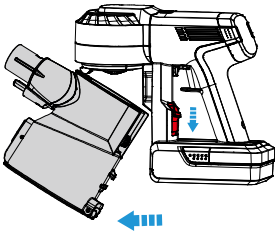

Press the dustbin release button and pull out.

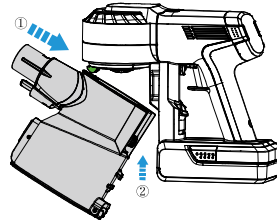

Incline the dustbin, the slot on the dustbin towards the hook on the main body. Push upward until the hook fixed into the slot. A 'click' sound will be heard when it has been successfully accomplished.

Install the Battery

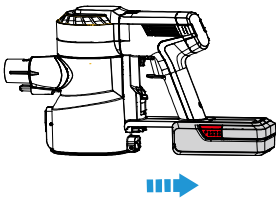

Press the battery release button, then pull the battery out.

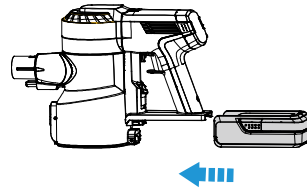

Slide the battery into the bottom of the main body. The battery will click into position when correctly fitted.

Install the Wall-mounted dock

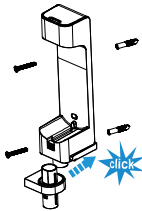

Assemble the two parts of the bracket, a 'click' sound will be heard when it has been successfully accomplished. Then install the wall-mounted dock to the wall with the nails provided by Tineco.

Warning:

- Please make sure there is no gas, water or electrical cables and wires behind the mounting area.
- To avoid the dock dropping down, please make sure it must be installed firmly.

Product Operation

Start to Work

Note:

- Before the first use, please charge the appliance (see "Charging the battery") for 3-4 hours in an area where the temperature is more than 39.2°F (4°C) but less than 104°F (40°C) and the above data based on the condition that the battery is cooled.
- Select the accessories according to needs (see "Accessory Instructions").

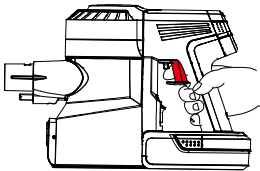

Press the switch button, the machine will start to work.
Lock the switch button for continuous power mode.

- After using the appliance, it is recommended to put it on the wall-mounted dock for recharge and storage.

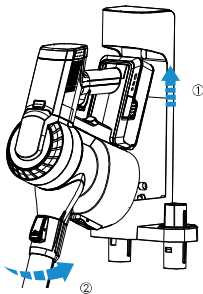

Place the main body on the docking station.

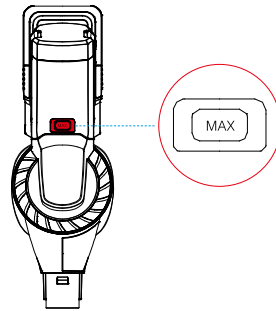

Press the MAX button to go between regular mode (regular power) and MAX mode (max power).

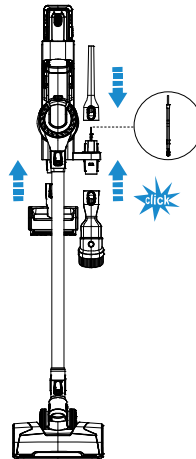

To avoid the deformation of the bristles, always put away the accessories on the docking station after use, a 'click' sound will be heard when it has been successfully accomplished.

Product Operation

Empty the Dustbin

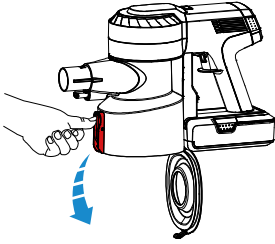

When finished, press the release button on the side of the dustbin and empty the contents.

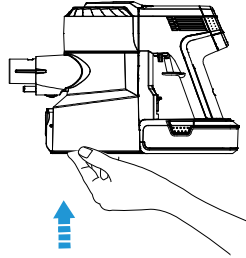

Reattach the dustbin's bottom cover.

Charging the Battery

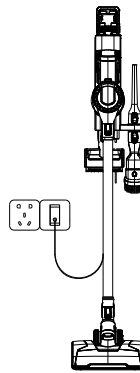
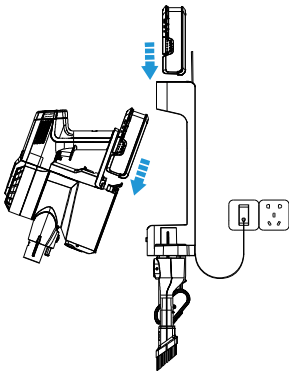

Connect the adaptor to docking station and outlet.

Charge the battery installed on the main body, or charge the battery separately. Dual adaptor can charge two battery packs at the same time.

Warning:

- Charge the battery only with the adaptor provided by TINECO.
- When you won't use the lithium battery for a long time, please store in a cool dry place. In this situation, please charge the battery every 3 months, and insure that the battery has been at least half charged (2 indicator lights of battery glow on regular mode).
- If you need an additional battery, please purchase from TINECO.
- Store appropriately indoors in a dry place. Do not expose machine to sunlight or freezing temperature. Recommended temperature range: 39.2°F (4°C)~104°F (40°C).

Product Operation

Working Time

- Working time last about 25 min. on regular mode, and about 10 min. on MAX mode.
- Data is obtained by Tineco laboratory using one battery and non-motorized accessories.

Charging Time

- Charging time takes about 3-4 hours.
- Based on results from Tineco lab tests. Lab test environment: temperature between 39.2°F (4°C) to 104°F (40°C).

Indicator Light

On Work



Three solid blue lights: Full power.



Two solid blue lights: Medium power.



One solid blue light: Low power.



One blinking red light: Out of power, or the appliance is blocked, or the battery is overheated.



One blinking pink light: The filters or the suction mouth is blocked.

During Charging



Three blue lights blinking successively: Charging.



One blinking red light: Fault, check Trouble Shooting.

Fully Charged



In 5 mins: Three solid blue lights.



5 mins later: Lights off.

Daily Maintenance

Note:

- Clean the dustbin and filters every time after use.
 - When pink light blinking, clean the pre-filter thoroughly with cleaning tool. To maintain better performance, wash the pre-filter once a month and **dry up**, replace it after 6 months of use.
- Also, please wash the HEPA every 3 months and **dry up**, replace it after 1 year of use.

Dustbin and Filters (pre filter, mesh filter and HEPA filter)

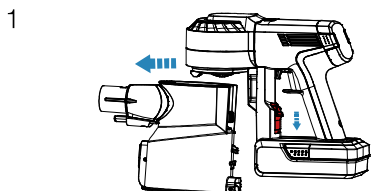

Press the dustbin release button, pull out the dustbin as indicated in the picture.

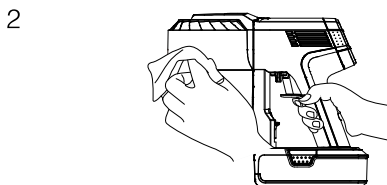

Clean with wet cloth.
Do not allow water to enter the appliance, especially not into motor and battery.

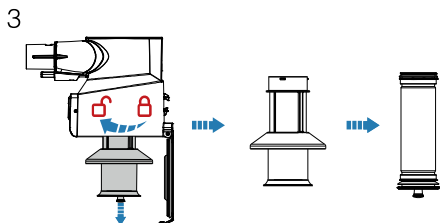

Twist anti-clockwise and remove the filters.

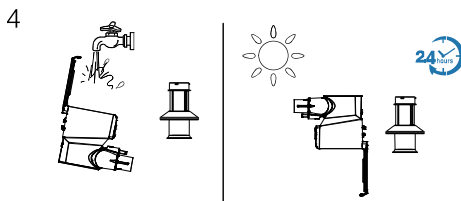

Clean the dustbin and mesh filter under cold, running water. The dustbin and mesh filter should be air dried completely before reinstalling.

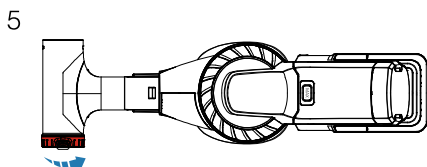

Clean the pre filter with Tineco Pre Filter Cleaning Tool. Take out the dirty pre filter and replace with a clean one. Put the dirty pre filter into the cleaning tool and connect it to the main body. Activate the appliance on MAX mode, and rotate the side cover.

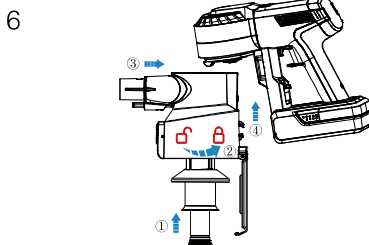

After cleaning, insert the clean pre filter into mesh filter properly, a 'click' sound will be heard once right into place. Install the clean filters and dustbin back into the main body, then reattach the dustbin cover.

Daily Maintenance

HEPA Filter

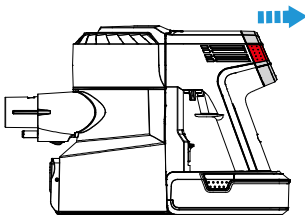

Press the HEPA release button on both sides of the windshield and gently pull out the HEPA. Please detach the battery pack before pulling out the HEPA to prevent the battery from contaminating.

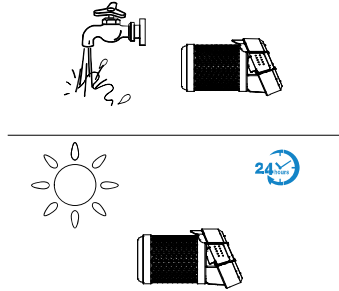

The HEPA can be washed under running water if necessary, and should be air dried completely before reinstalling.

Brush

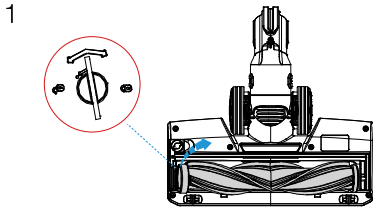

1 Use a coin or other tool, to unlock the brush roller lock, then remove the brush from the brush window. Please see the above image.

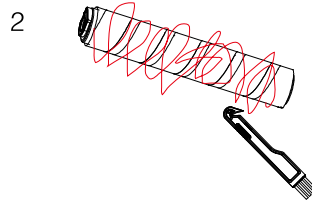

2 Remove the hair and debris wrapped around the roller with Tineco Hair Cleaning Tool.

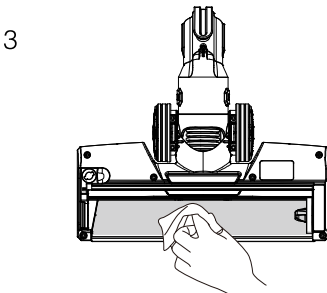

3 Gently clean the transparent brush window.

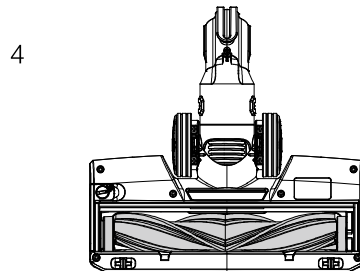

4 After the cleaning, install the brush into the machine.

Specification

Model	A11 Series
Voltage	21.6V 2000mAh Li-ion
Rated Power	450W
Dustbin Capacity	0.6L
Charging Time	3-4 hrs
Charging Input	100-120V~
Running Time	25*2 min.(MAX mode: 10*2 min.)

Disposal

- The battery contains materials that are harmful to the environment and must be removed from the appliance before it is discarded.
- When removing the battery, the appliance must be powered off.
- Waste batteries should be handled properly. Do not put them into fire, water or soil. 
- If the battery leakage touches the skin or clothing, flush with water immediately to avoid skin injury and seek medical help.

Trouble Shooting

Problem	Possible cause	Solution
The appliance doesn't work	No power	Charge the battery
	The suction mouth is blocked	Check and remove blockages
Weak suction power	Dustbin and filters are full of dust	Empty and clean dustbin and filters
	The brush roller is wrapped by hairs or fibers	Clean the brush roller
	The pre filter is not installed	Install the pre filter
	The appliance is blocked (such as tube, suction mouth or some other part)	Remove blockages
Abnormal motor sounds	The appliance is blocked (such as tube, suction mouth or some other part)	Remove blockages
Battery can not be charged	The battery is not correctly placed	Remove the adaptor and insert again
Red light blinking, main body continues working while the brush stops	The brush is blocked	Stop the appliance and clean the brush roller
One blinking red light	Out of power, or the battery is overheated, or the appliance is blocked	Charge the battery, or cool down the battery, or remove blockages
One blinking pink light	The filters or the suction mouth is blocked	Clean filters or remove blockages

Note:

If the above solutions can not solve the problem, please contact us at support@tineco.com or visit our website www.tineco.com for further support.

Warranty

The 2-Year Limited Warranty

Applies to purchases made from authorized retailers of TINECO.

According to the requirements outlined in this instruction manual, subject to the following conditions and exclusions.

WHAT IS COVERED?

- Your TINECO machine has a 2-year warranty against original defects in material and workmanship, when used for private household purposes in accordance with the TINECO Instruction Manual.
- This warranty provides, at no extra cost to you, all labor and parts necessary to ensure your machine is in proper operating condition during the warranty period.
- This warranty will only be valid if the machine is used in the country in which it was sold.

WHAT IS NOT COVERED?

TINECO shall not be liable for costs, damages or repairs incurred as a result of:

- Machines purchased from an unauthorized dealer.
- Careless operation or handling, misuse, abuse and/or lack of maintenance or use not in accordance with the TINECO Instruction Manual.
- Use of the machine other than for normal domestic purposes, e.g. for commercial or rental purposes.
- Use of parts not in accordance with the TINECO Instruction Manual.
- Use of parts and accessories other than those produced or recommended by TINECO.
- External factors unrelated to product quality and use, like accidental water damage.
- Repairs or alterations carried out by unauthorized parties or agents.
- Failing to clear blockage and other hazardous material from the machine.
- Normal wear and tear, including normal wearing parts, such as clear bin, belt, filter, HEPA, brush bar, and power cord (or where external damage or abuse is diagnosed), carpet or floor damage due to use not in accordance with manufacturer's instructions or failure to turn the brush bar off when necessary.
- Reduction in battery discharge time due to battery age or use.

Warranty

WARRANTY LIMITATIONS

- Any implied warranties relating to your machine including but not limited to warranty of merchantability or warranty of fitness for a particular purpose, are limited to the duration of this warranty.
- Warranty coverage applies to the original owner and to the original battery only and is not transferable.
- This limited warranty gives you specific legal rights. You may also have other rights which vary by region.
- Manufacturer's warranties may not apply in all cases, depending on factors such as use of the product, where the product was purchased, or who you purchased the product from.

Please review the warranty carefully, and contact the manufacturer if you have any questions.

WARRANTY SERVICE

Register: Highly recommend you to register your machine on Tineco official website and enjoy exclusive benefits.

Failure to register your product won't diminish your warranty rights.

How to Claim: Please keep your proof of purchase. To make a claim under our Limited Warranty, you need to provide your serial number and the original purchase receipt with the purchase date and order number on it.

All work will be carried out by TINECO or its authorized agency.

Any replaced defective parts will become the property of TINECO.

Service under this warranty will not extend the period of this warranty.

If your machine is not functioning properly, please email us: support@tineco.com

Call our Customer Service:

1-855-292-8864

Or email our Customer Service:

support@tineco.com

Visit TINECO Website:

www.tineco.com

tineco
Live Easy
Enjoy Life



tinecoglobal 



 1-855-292-8864 Mon. - Fri. 9am - 6pm (CST)

 support@tineco.com

 www.tineco.com

Contact us - We'll get back to you within 1 business day.