











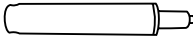
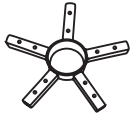

# INSTRUCTION MANUAL

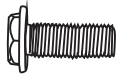
# Package List

- Without further ado, we kindly suggest you to list all parts needed for the chair first.

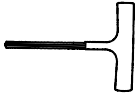
(1)*1 <b>Back</b> 	(2)*1 <b>Seat</b> 	(3)*2 <b>Armrests</b> 
(4)*1 <b>Seat Plate</b> 	(5)*1 <b>Gas Lift</b> 	(6)*1 <b>Star Base</b> 
(7)*5 <b>Base Legs</b> 	(8)*5 <b>Casters</b> 	(9)*4 <b>Bolts M6*20mm</b> 
(10)*8 <b>Bolts M6*25mm</b> 	(11)*10 <b>Bolts M6*14mm</b> 	(12)*8 <b>Plastic Caps</b> 
(13)*1 <b>Wrench</b> 		

# Assembly Instruction

**STEP 1 :** Connect Star Base(6) and Five Base Legs(7) with Ten M6\*14mm Bolts(11), then turn the Star Base upside down, and press the Casters(8) into the holes at the end of each base leg.

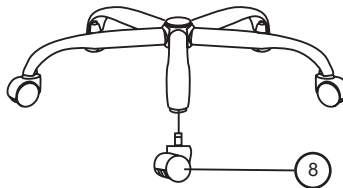
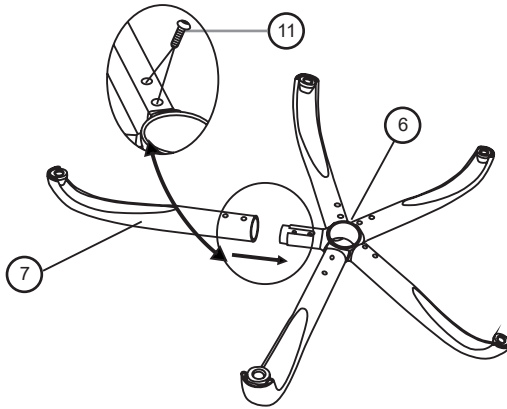

## STEP 2 :

Turn the Star Base upright and insert the Lift(5) into the center hole of the Star Base.

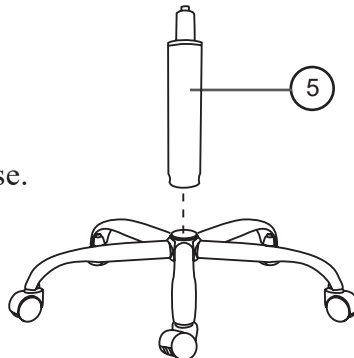

**STEP 3 :** Align the Seat Plate(4) over the pre-drilled holes underneath the Seat Cushion(2), make sure that the front of the seat plate is facing the front of the Seat Cushion. Attach the Seat Plate to the Seat Cushion using Four Bolts M6\*20mm(9), tighten all the bolts with the Wrench(13), being careful not to miss-thread the bolts or damaged the seat.

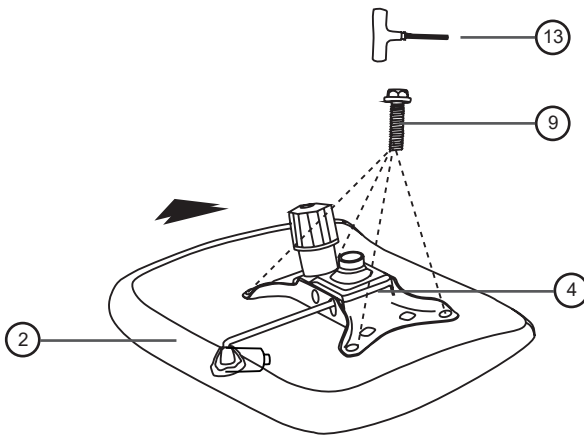

**STEP 4 :** Turn the Seat Cushion(2) upright and align the center hole of the seat plate over the lift, then push the seat cushion down onto the lift firmly until the connection is secure.

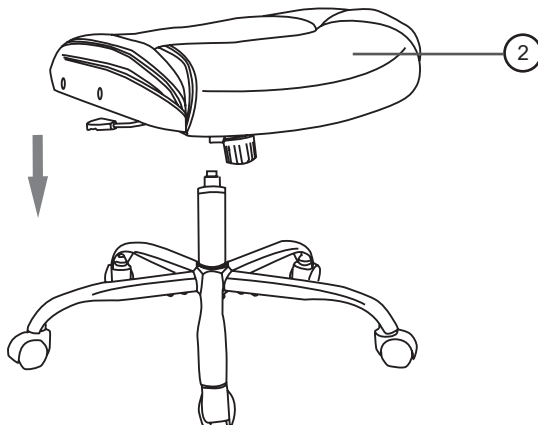

**STEP 5:** Attach the Arms(3) to the Seat Cushion(2) with Four Bolts M6\*25mm(10), using the Wrench(13).

*Note 1: Arm rests are labeled with an "L" (left) or "R" (right) to show which sides they should be placed on.*

*Note 2: Do not tighten all the bolts to 100%, make sure it have space to adjust in the next steps.*

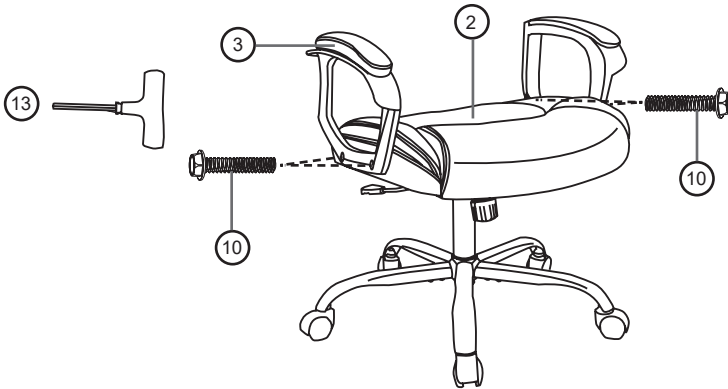

**STEP 6:** Lay the Back Cushion on the seat of the chair with the top of the cushion toward the front. Attach the Back Cushion(1) to the Arms by inserting Two Bolts M6\*25mm(10) in the Lower holes with the Wrench(13).

*Note : Do not tighten all the bolts to 100%, make sure it have space to adjust in the next steps.*

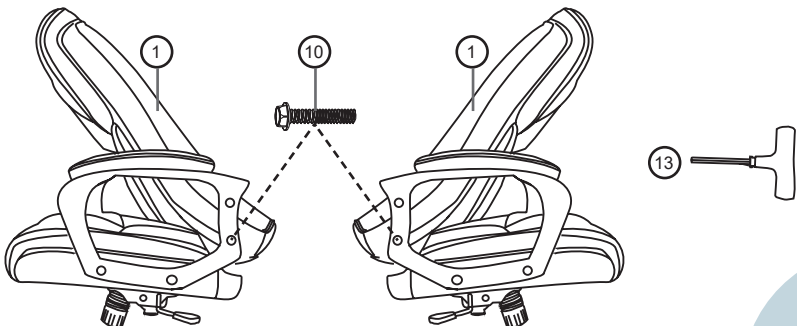

**STEP 7 :** Rotate the back of the chair up, then secure it with the Top Two Bolts M6\*25mm(10) with the Wrench(13). Adjust the balance on each side of the chair, and fully tighten all the bolts at this step.

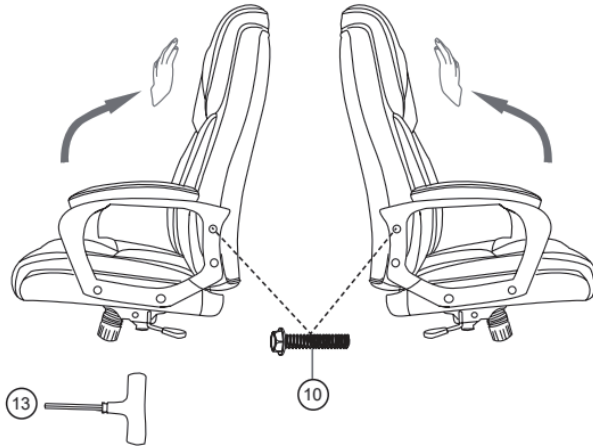

## STEP 8 :

Press the Plastic Caps(12) into the Arms holes to cover the bolts.

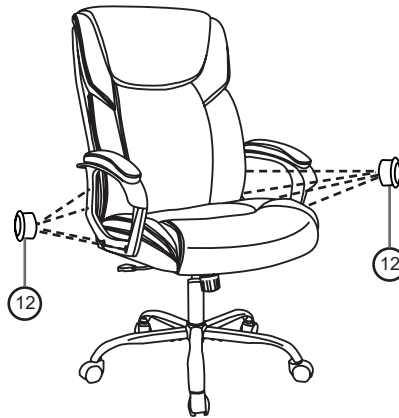

## CAUTION:

Make sure all bolts and screws are fully tightened before using chair. Lubricate all moving parts and tighten all bolts/screws every 6 month or whenever needed.

# Instructions For Use

## 1. Seat Height: Paddle-shaped lever on the right side

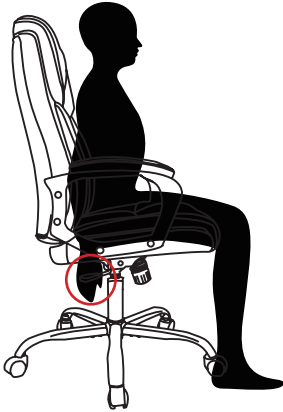

To raise:

While taking your weight off chair, lift lever up.



To lower:

While seated, lift lever up.

\* At the proper height, your feet should rest flat on the floor.

## 2. Tilt Tension: Long stem under the seat with knob

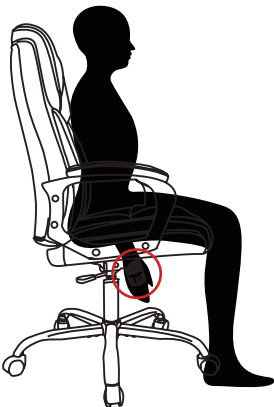

To increase tension:

While seated, turn knob forward (toward + sign).



To decrease tension:

While seated, turn knob backward (toward - sign).

\* Set the tilt tension to control the resistance you feel when leaning back.

### 3. Operating the tilt lockout

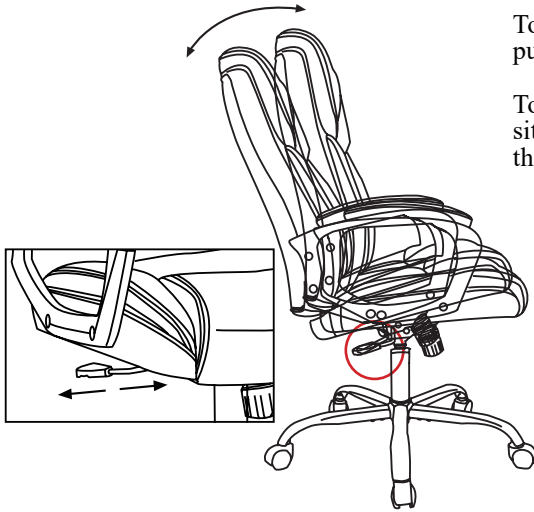

To let your chair tilt back,  
pull the control handle out.

To stop your chair from tilting,  
sit forward, then push  
the control handle in.