

Instant Pot® Max Series



User Manual

Instant Pot® Free Recipe App

- 500+ Free Recipes
- New User Tips
- Getting Started Videos



Welcome to the World of Instant Pot® Cooking!

Thank you for selecting an Instant Pot® smartcooker! Our vision for Instant Pot® is to provide you with the right tools to enhance your food preparation experience. Our smartcookers are designed to save you time, replace a number of appliances, and prepare healthy and tasty meals in a convenient and dependable way.

We partner with chefs, authors, and bloggers to compile a collection of recipes that we hope you enjoy! As well, for over 500+ additional recipes, videos and more, download the Instant Pot® Recipe App.

Happy Instant Pot® Cooking!

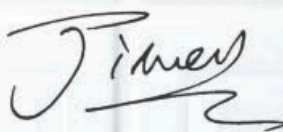

Robert J. Wang
Founder, CEO



Table of Contents

Important Safeguards	1- 3
Product Specifications	3
What's Included	4
Lid Structure	5
Cooker Base Structure	6
Getting Started	7 - 10
Control Panel	11 - 12
Venting Methods	13
Initial Test Run (<i>15 psi Water Test</i>)	14 - 15
System Settings & Time	16
Operation Field	
Delay	17
Keep Warm	18
Usage Tips	19
Cooking Tips	20
Smart Programs & Advanced Features	
Pressure Cook	21
<i>NutriBoost™</i>	22
Canning	23 - 26
Sauté	27
Slow Cook	28
Sous Vide	29 - 30
Cooking Guidelines	31
Yogurt	32
Care & Cleaning	33
Troubleshooting	34 - 36
Warranty	37 - 38
Index	39

Read the manual carefully and retain for future use.

IMPORTANT SAFEGUARDS

When using electrical appliances, basic safety precautions should always be followed:

1. READ ALL INSTRUCTIONS.
2. Do not touch hot surfaces. Only use side handles for carrying or moving.
3. **⚠ CAUTION** Do not place the appliance on or in close proximity to a hot gas or electric burner, or a heated oven; heat from an external source will damage the appliance.
4. **⚠ CAUTION** Do not use near water or flame. Please keep out of direct sunlight.
5. **⚠ CAUTION** Extreme caution must be used when moving the appliance containing hot liquids. Do not move the appliance when it is under pressure.
6. Do not use appliance for anything other than intended use.
7. For household use only. Do not use outdoors. Not for commercial use.
8. This appliance cooks under pressure. Improper use may result in scalding injury. Make certain the appliance is properly closed before operating. Refer to the “Getting Started” section.
9. Do not fill the appliance over $\frac{2}{3}$ full. When cooking foods that expand during cooking such as rice or dried vegetables, do not fill the appliance over $\frac{1}{2}$ full. Over filling may cause a risk of clogging the vent pipe and developing excess pressure. Refer to the “Pressure Cooking” section.
10. Before each use, check the steam release valve/handle, steam release pipe, anti-block shield and float valve for clogging. Refer to the “Getting Started” section.
11. Do not open the appliance until the appliance has depressurized and all internal pressure has been released. If the float valve is still up and/or the lid is difficult to open, this indicates that the appliance is still pressurized – do not force it open. Any pressure in the appliance can be hazardous. Refer to the “Getting Started” section for instructions to safely remove lid.
12. Do not use this appliance for deep frying or pressure frying with oil.
13. Do not lean over or place your hands or face over the steam release valve/handle or float valve when the appliance is in operation or has residual pressure. Do not touch the metal portion of the lid when the appliance is in operation; this could result in injury.



Read and save these safety guidelines.

Failure to adhere to these safety guidelines may result in serious injury.

IMPORTANT SAFEGUARDS

14. Do not cover or obstruct the steam release valve/handle and float valve with cloth or other objects. Obstructing the steam release valve/handle and float valve can create a safety issue and may cause injury.
15. Turn the appliance off if steam escapes from the steam release valve/handle or float valve in a steady stream for longer than 3 minutes. There may be residual pressure in the appliance. Allow the appliance to depressurize naturally or release all excess pressure before opening. Refer to the “Troubleshooting” section.
16. Turn the appliance off if steam escapes from the sides of the lid and ensure sealing ring is properly installed. Refer to the “Getting Started” section.
17. **⚠CAUTION** To protect against electrical shock, do not immerse the power cord, plugs, or appliance in water or other liquid.
18. A short power supply cord (35 in / 0.9 m) is provided to reduce the hazards resulting from it being grabbed by children, becoming entangled in, or tripping over a longer cord.
19. Always attach plug to appliance first, then plug cord into power source. To disconnect, turn appliance OFF, then remove plug from power source.
20. Unplug from outlet when not in use and before cleaning. Allow to cool before putting on or taking off parts, and before cleaning or storage.
21. Do not operate any appliance with a damaged cord or plug. Do not operate if the appliance malfunctions or has sustained damage of any kind, including damage to the rim or bottom of the inner pot. Contact the Customer Care Team.
22. **⚠CAUTION** Do not let power cord hang over edge of table or counter, or touch hot surfaces.
23. Intended for countertop use only. Keep the appliance on a stable, heat-resistant platform. Do not place on anything that may block the vents on the bottom of the appliance. Do not place on hot stove.
24. **⚠WARNING** Spilled food can cause serious burns. Keep appliance and cord away from children. Never drape cord over edge of counter, never use outlet below counter, and never use with an extension cord.
25. When cooking meat with skin (e.g. sausage with casing), the skin can swell when heated. Do not pierce the skin as long as it is swollen; this could result in scalding injury.



Read and save these safety guidelines. Failure to adhere to these safety guidelines may result in serious injury.

IMPORTANT SAFEGUARDS

26. When pressure cooking food with a doughy or thick texture, or a high fat/oil content, contents may splatter when opening the lid. Please follow recipe instructions for pressure release method. Once steam is fully released, gently shake the appliance with extreme caution and then if necessary, release the steam again before removing the lid. Refer to the “Venting Methods” section.
27. **⚠CAUTION** Before inserting the inner pot into the appliance, wipe the outer surface of the inner pot and cooking element to confirm they are dry and free of food debris. Refer to the “Care & Cleaning” section.
28. Do not attempt to repair, replace, or modify components of the appliance, as this may cause electric shock, fire or injury, and will void the warranty.
29. Do not tamper with any of the safety mechanisms.
30. Do not use appliance in electrical systems other than 120V/60Hz for North America. Do not use with power converters or adapters.
31. Close supervision is necessary when the appliance is used near children.
32. This appliance should not be used by children; by individuals whose physical, sensory or mental abilities may prevent safe use of the appliance; or by individuals with limited knowledge of how to use the appliance. Close supervision is needed when using this appliance near these individuals.
33. To reduce the risk of electric shock and pressure leakage, cook only in a removable container authorized by the manufacturer.
34. The use of accessory attachments not recommended by the appliance manufacturer may cause injuries.

SAVE THESE INSTRUCTIONS.

Product Specifications



Model: Max



1100 W



120V ~ 60Hz



6 Quart
5.7 Litres



13.25 lb
6.01 kg



in: 13.8L x 13.8W x 13H
cm: 35L x 35W x 33H



WARNING

Read and save these safety guidelines.
Failure to adhere to these safety guidelines may result in serious injury.

What's Included

Before using the Instant Pot® Max, remove all packaging materials and accessories from in and around the pressure cooker, and verify that all parts are accounted for. Pay attention to Important Safeguards and operation instructions. Remove all warning cards and hanging tags after reading. Do not remove safety warning stickers placed on top of lid and back of cooker base.

Watch the "Unboxing" video: www.InstantPot.com/faq/instant-pot-help-video



Lid



Cooker Base



Inner Pot



Rice
Measuring
Cup



Soup Spoon
& Rice Paddle



Steam Rack
with Handles



Silicone
Mini Mitts



Silicone Sealing Ring
(currently installed within lid)



Condensation Collector



Detachable
Power Cord



Quick
Start Guide



User
Manual



Recipe Booklet



Cooking Time Tables

Lid Structure

When attached to the base, the lid becomes powered, enabling an automated venting process to occur during and after cooking. This technology also enables the thermal sensor to transmit temperature readings to the cooker base for precision cooking.

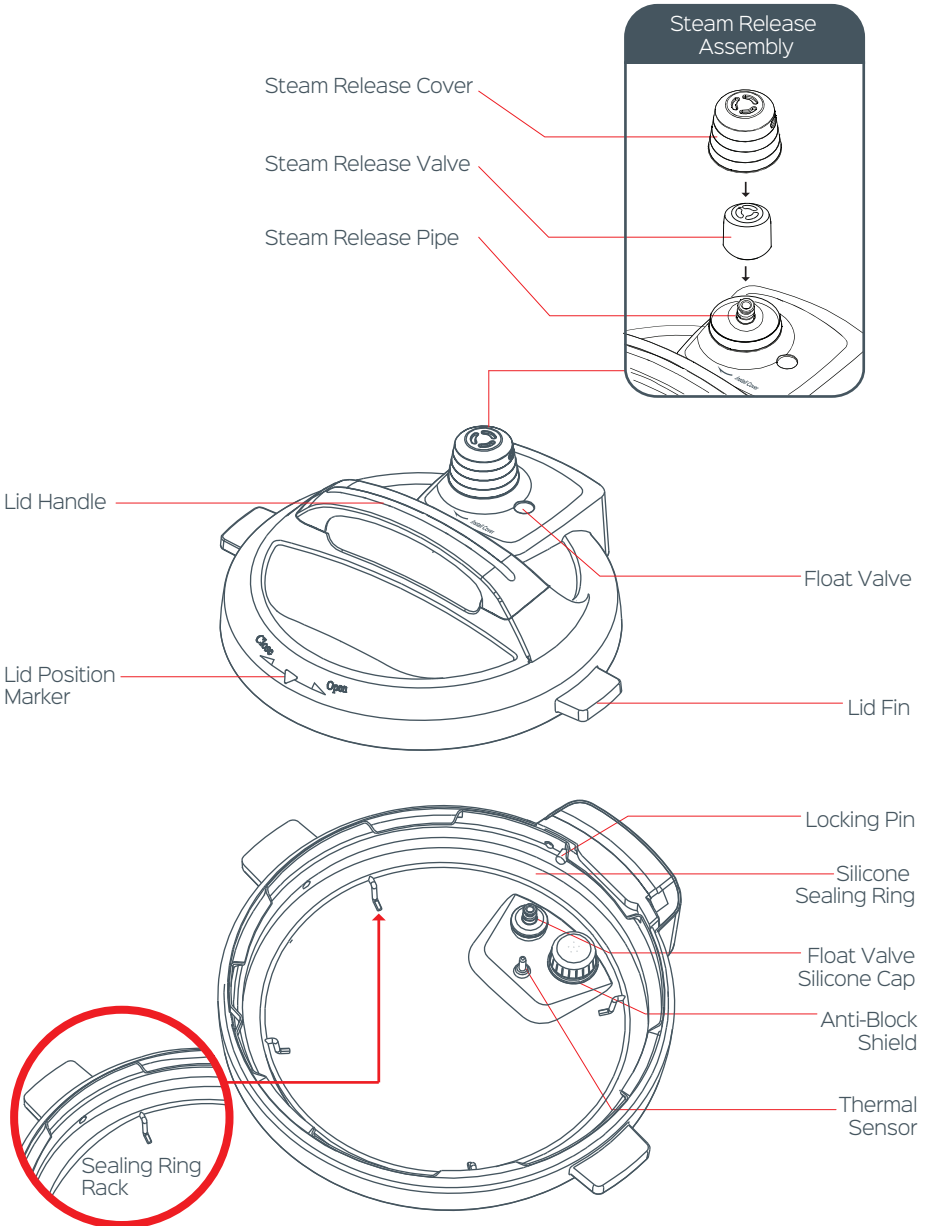

Cooker Base

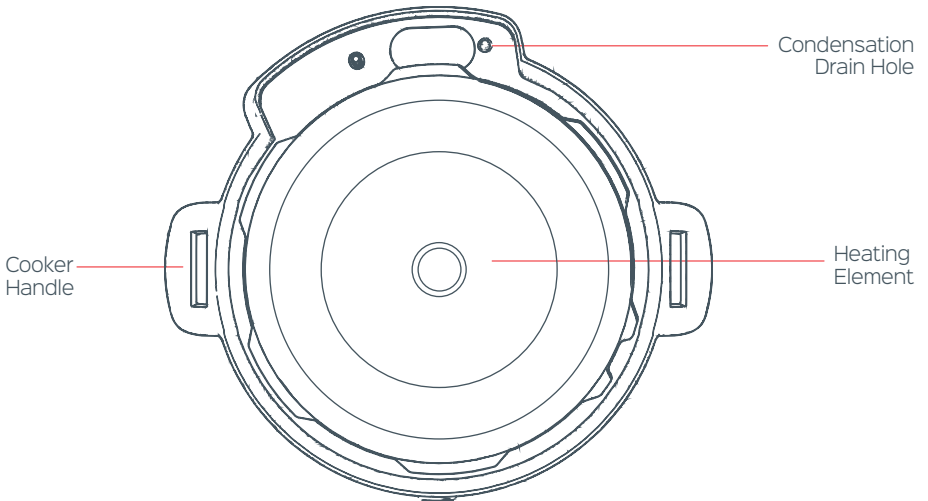
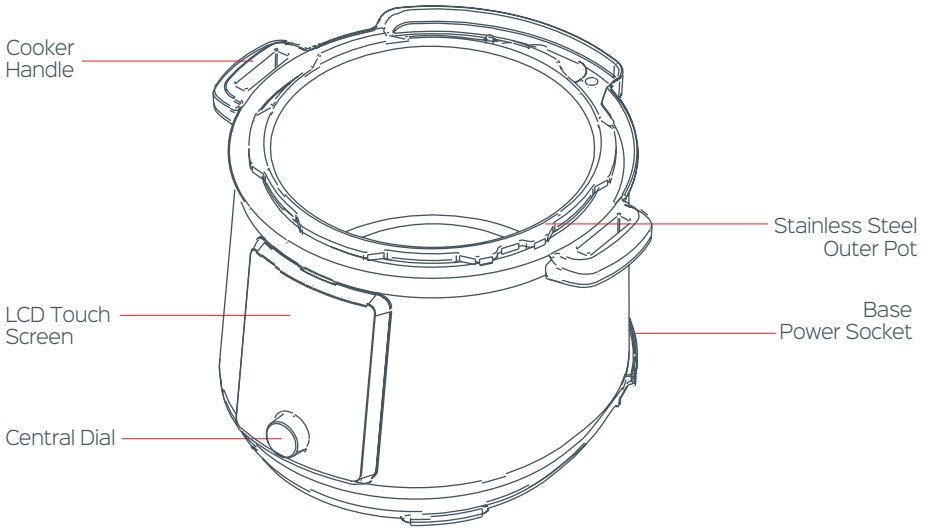

INSTANT TIP: The Cooker Handles are also a Lid Holder

The lid has been designed with lid fins that fit perfectly inside the cooker handles on the left and right sides of the cooker base.

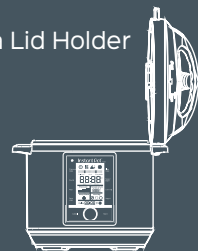

Getting Started

1 Read all Important Safeguards

Read all Important Safeguards and instructions. Do not remove Safety Warning Sticker placed on the lid and Rating Label placed on back of cooker base.

Place the cooker on a stable surface.

⚠ CAUTION Do not place the appliance on or in close proximity to a hot gas or electric burner, or a heated oven; heat from an external source will damage the appliance.

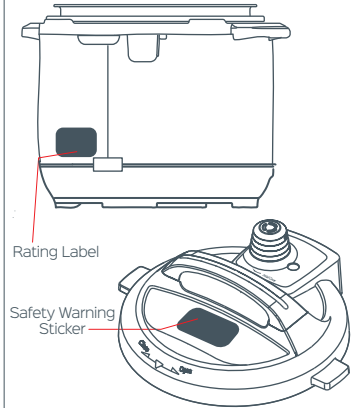

2 Install the Condensation Collector

The condensation collector has grooves on either side that fit over the condensation collector tabs on the cooker base. Align the condensation collector grooves over the tabs and push the condensation collector into place.

The condensation collector captures any moisture that develops during cooking and should be cleaned after each use.

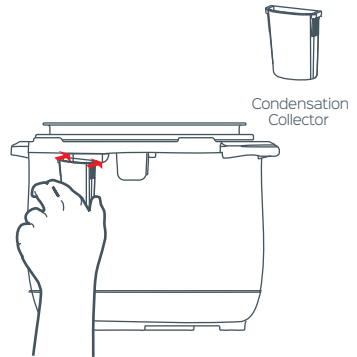

3 Open & Close the Lid

▲ **To Open:** Remove the lid by gripping the handle and turning the lid counter-clockwise until the symbol on the lid is aligned to the arrow symbols on the cooker base. Lift the lid up from the cooker base.

▼ **To Close:** Align the arrow symbol on the lid to the unlock symbol on the rim of the cooker base, then turn the lid clockwise until the lid fins line up over the cooker base handles.

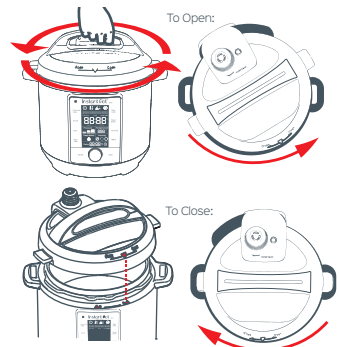

Getting Started

4 Remove & Install the Steam Release Assembly

The steam release valve and cover must be installed during use.

Remove the Steam Release Cover: Turn the steam release cover counter-clockwise until it can be pulled off from the lid.

Remove the Steam Release Valve: Pull the steam release valve up and off the steam release pipe.

Install the Steam Release Valve: Place the steam release valve onto the steam release pipe and press down.

Install the Steam Release Cover: Place the steam release cover over the steam release valve and turn the steam release cover clockwise until it locks securely in place.

Note: The steam release valve will pop into place, but will fit loosely when it is seated properly in place—this is required for proper function. You should feel some resistance as you remove or install the steam release valve. This part should be inspected and cleaned frequently, especially after cooking the foamy foods.

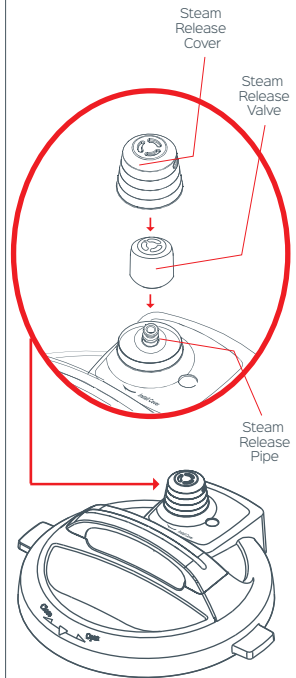

5 Remove & Install the Anti-Block Shield

The anti-block shield must be installed during use.

To remove: Grip the lid like a steering wheel. Using your thumbs for leverage, press firmly against the side of the anti-block shield (pressing towards the side of the lid and up) until it pops off. The anti-block shield will snap off of the prongs underneath.

To install: Press the anti-block shield over the prongs and press down until it snaps into place.

Note: The anti-block shield prevents food particles from clogging the steam release pipe. These fine particles can become trapped underneath the shield and prevent pressure regulation. The anti-block shield should be removed for regular cleaning.

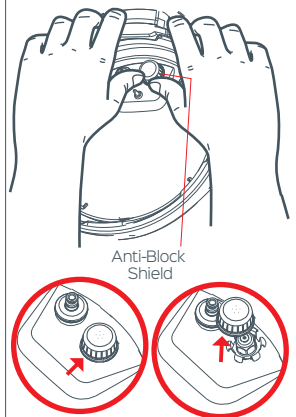

Getting Started

6 Remove & Clean the Inner Pot

Remove the inner pot from the cooker base. Before inserting the inner pot into the appliance, wipe the outer surface of the inner pot and heating element to confirm they are dry and free of food debris. Failure to do so may damage the cooker.

The curvature of the inner pot matches the heating element. Always use an Instant Pot® authorized inner pot when cooking.

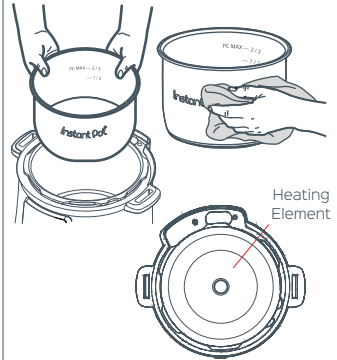

7 Check the Sealing Ring & Sealing Ring Rack

Ensure the sealing ring is sitting snugly behind the sealing ring rack. The sealing ring creates an airtight seal between the lid and the cooker base. The sealing ring must always be installed during use.

Remove: Pull the sealing ring out from behind the sealing ring rack, set it aside. Inspect the sealing ring rack. It is centered in the lid and the same height all the way around. Do not attempt to repair a deformed ring rack.

Install: Place the sealing ring over the sealing ring rack, and use your thumbs to press it into place.

Note: Always check for cracks, wear, or deformation in your sealing ring prior to cooking.

Only use genuine Instant Pot® sealing rings. Failure to do so will void the warranty.

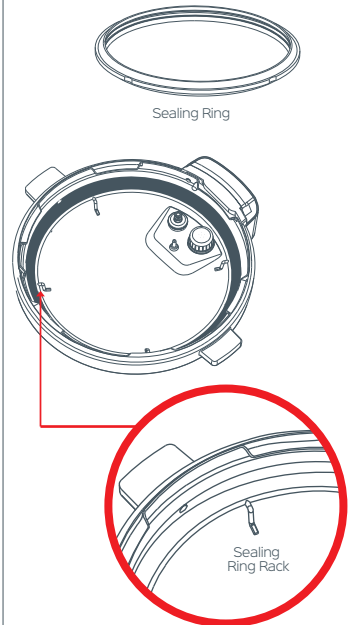

8 Secure the Power Cord

Secure the power cord into the base power socket before connecting to a 120V power source. The pressure cooker will remain in Standby mode when plugged in but not in operation.

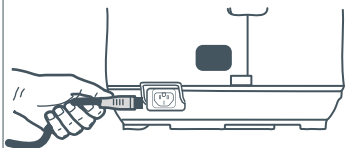

Getting Started

9 Remove & Re-Install the Float Valve

The float valve and silicone cap are essential to pressure cooking, as they seal in the pressurized steam.

The float valve has 2 positions:

Down: cooker is depressurized

Up: cooker is pressurized

CAUTION While the float valve is up, the contents of the cooker are pressurized. Do not attempt to remove the lid. Refer to “Venting Methods” section in this manual for information on releasing pressure.

To test: Hold the lid by the handle and reach underneath to test the float valve’s movement.

It will have a ¼ inch (½ cm) range of up-and-down motion.

To remove: Place one finger on the flat top of the float valve, turn over the lid and detach the silicone cap from the bottom side of the float valve. Do not discard the silicone cap!

Once disconnected, the float valve can be removed from the top of the lid.

To install: Drop the float valve into the float valve hole on top of the lid. Then, place one finger on the flat top of the float valve, turn the lid over, and press the silicone cap back into place on the bottom of the float valve.

Note: Regular removal and cleaning of the float valve and surrounding area is essential to ensure proper function of your Instant Pot®.

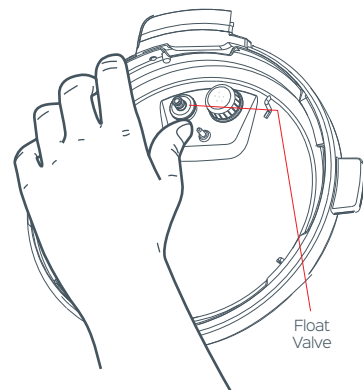
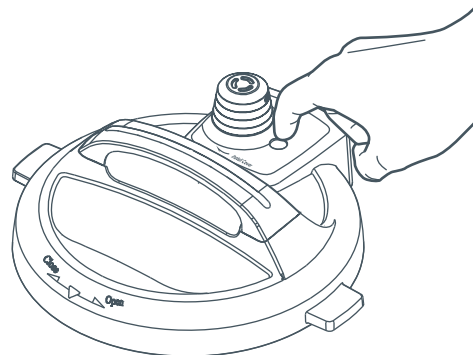
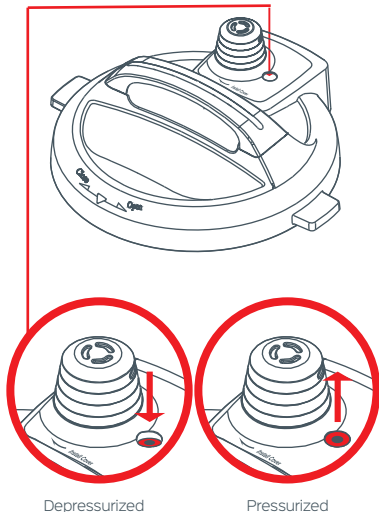

Control Panel

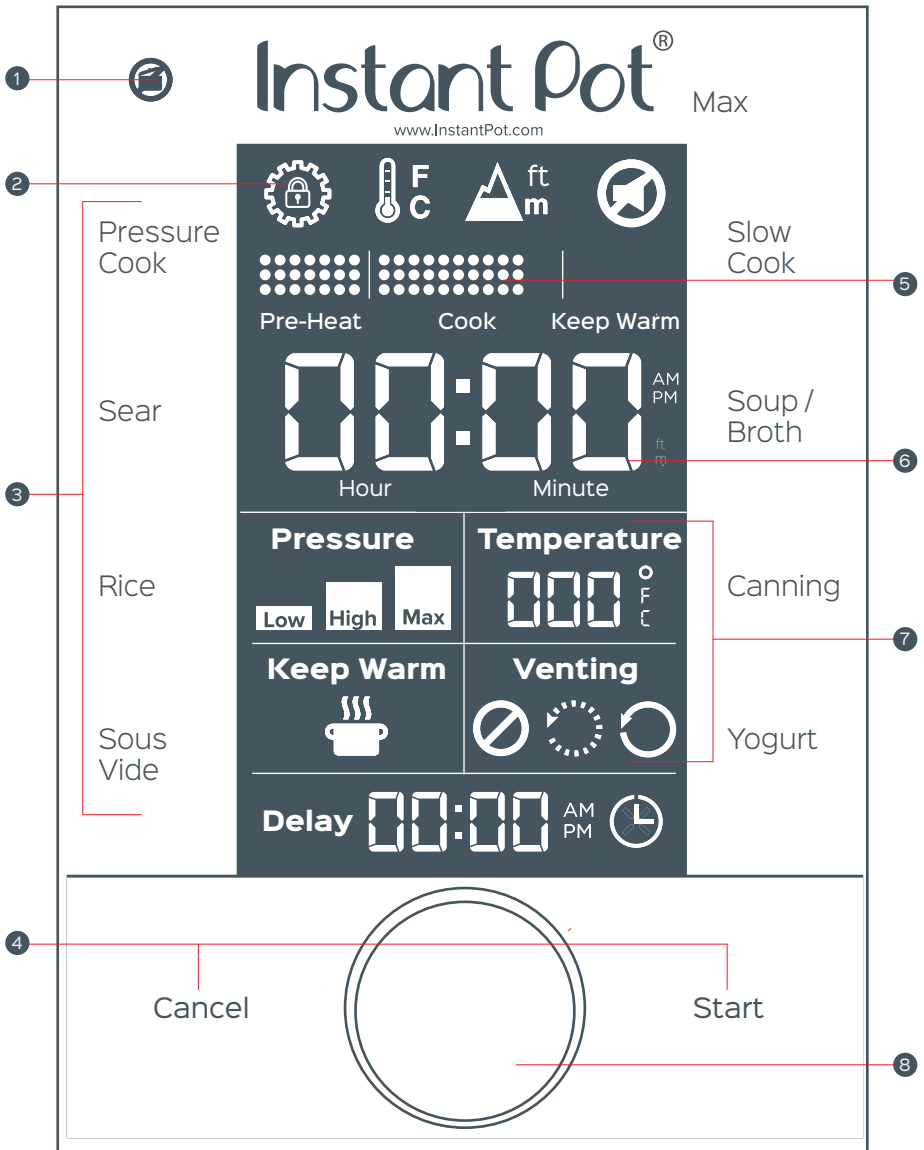

1 Pressure Indicator

The icon will be lit when the pressure cooker is still pressurized, indicating that the lid is locked and cannot be removed

2 System Settings

- Lock / Unlock
- Temperature Display: Fahrenheit (°F) or Celsius (°C)
- Altitude Display: feet (ft) or meters (m)
- Sound (ON / OFF)

3 Smart Programs

- Pressure Cook
- Sauté
- Rice
- Sous Vide
- Slow Cook
- Soup / Broth
- Canning
- Yogurt
- Manual Keep Warm

4 Control Keys

- Cancel
- Start

5 Cooking Progress Indicator

Real-time cooking temperature display & cooking progress:

- Pre-Heat Status
- Cook Status
- Keep Warm Status

7 Smart Program Settings

- Pressure (Low / High / Max)
- Temperature (Low / High / Custom)
- Keep Warm (Automatic / Manual)
- Venting Options (Natural Release, Pulse Release & Quick Release)

6 Local Time & Cooking Display

- Standby Mode: 12-hour AM / PM clock
- In-Program Time: hour & minute

8 Central Dial

Turn the central dial to adjust the time, temperature & altitude

Venting Methods

Your pressure cooker has an automated venting system for post-cooking pressure release, which can be activated on pressure cooking Smart Programs when desired. The default venting method is Natural Release (NR). To stop or pause once a venting method has begun, touch the **Venting** field and the pressure cooker will automatically return to NR.

There are 3 methods to release pressure:

Natural Release (NR)

This setting allows the pressure cooker to dissipate heat and pressure release naturally over time. This method must be used when cooking food that is thick or starchy, such as soups, stews or chilies, as well as food that expands, such as beans and grains. It is also commonly used when cooking clear broths, as it allows for the liquid to cool while undisturbed, resulting in crystal clarity.

Note: Depressurization time will vary, based upon the volume of food / liquid and a variety of other factors.

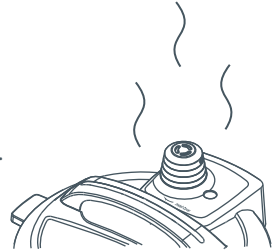

Quick Release (QR)

A short warning burst will be released, followed by a continuous stream of steam. This method is most commonly used when cooking vegetables, fish, eggs or other foods that may overcook during NR or PR.

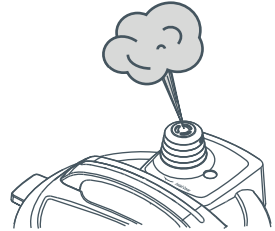

Pulse Release (PR)

This method of venting releases incremental bursts of steam at precisely programmed intervals.



 WARNING			
			
Do not lean over the steam release cover.	Do not place unprotected skin over the steam release cover.	Do not cover the steam release cover.	When the Pressure Indicator is lit, do not open the lid.

Initial Test Run (15 psi Water Test)

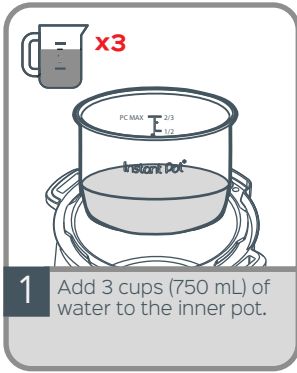

1 Add 3 cups (750 mL) of water to the inner pot.

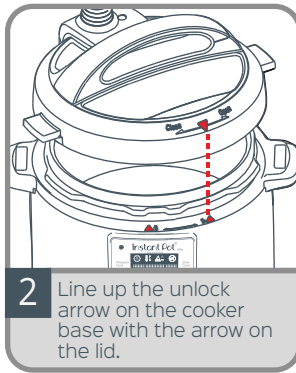

2 Line up the unlock arrow on the cooker base with the arrow on the lid.



3 Turn the lid clockwise to close until a jingle sounds.



4 Touch Pressure Cook.



5 Touch Minute to adjust the cook time.

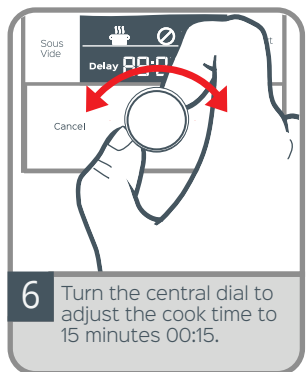

6 Turn the central dial to adjust the cook time to 15 minutes 00:15.

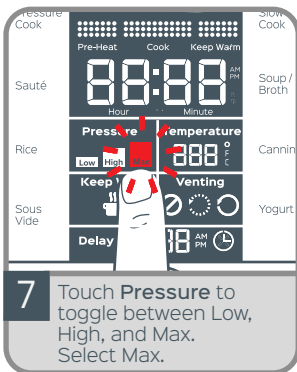

7 Touch Pressure to toggle between Low, High, and Max. Select Max.

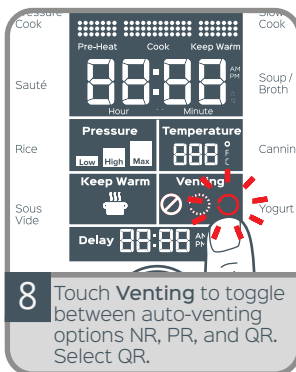

8 Touch Venting to toggle between auto-venting options NR, PR, and QR. Select QR.



9 Touch Start to begin cooking. 3 beeps will sound.

Initial Test Run (15 psi Water Test)

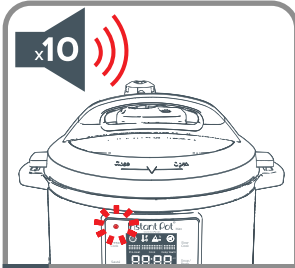

10 When the Smart Program has completed, 10 beeps will sound.



11 A short warning burst will be released, followed by a continuous stream of steam.

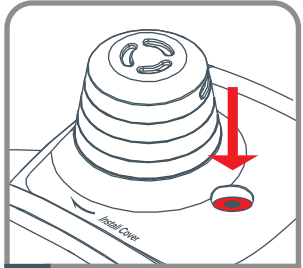

12 The float valve will drop to indicate the pressure has been fully released.

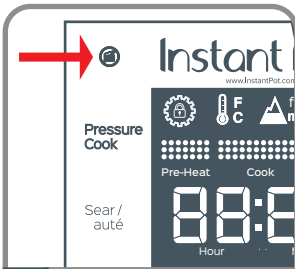

13 Once the Pressure Indicator has turned OFF you may open the lid.

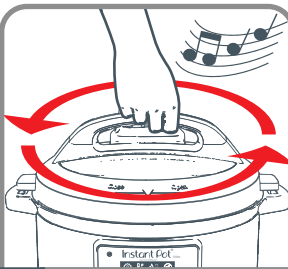

14 Turn the lid counter clockwise to open until a jingle sounds.

CAUTION

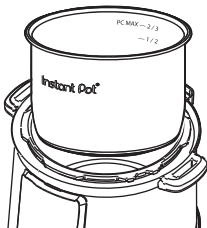

Do not pour food or liquid into cooker base. To avoid risk of personal injury and/or property damage, always cook with the inner pot in place.

System Settings & Time



Adjust the System Settings:

The system settings will remain on your display so you always know which ones are in effect. To change your system settings:

1. Touch **Cancel** to ensure the cooker is in standby mode.
2. Touch the System Settings icon (when in standby mode). Note that the padlock symbol disappears. This means that your system settings are “unlocked”, and you can now alter them as you wish.



Adjust Temperature Display:

Touch the Temperature Display icon to toggle between Celsius (°C) or Fahrenheit (°F). The symbol that is flashing indicates your current selection.



Adjust Altitude Display:

Set your present altitude on the smartcooker before setting the cook time. The smartcooker will adjust the cook time automatically based on your altitude settings.

1. Touch the icon to toggle between feet (ft) or meters (m). The symbol that is flashing indicates your current selection.
2. Once the unit has been selected, turn the central dial to adjust the altitude.



Turn Sound ON & OFF:

Touch the Sound icon to toggle the Sound **ON** or **OFF**. Error code alerts cannot be silenced.

Set Local Time:

1. Touch the ‘Hour’ field, then turn the central dial to adjust.
2. Next, touch the ‘Minute’ field and turn the central dial to adjust.

If you scroll past 12:00, the AM / PM will switch automatically.



Lock the System Settings:

Touch the System Settings icon to lock in your selections. Note that the padlock symbol will reappear to indicate that your selections are "locked in". If you do not lock your settings, no changes will be saved. If you do not wish to save your settings, touch the **Cancel** key (or wait 10 seconds and the settings will return to the previous selection).

Default Reset (Specific Smart Program):

When the pressure cooker is in standby mode, touch the Smart Program to be reset. When the Smart Program starts flashing, touch and hold the **Cancel** key for 2-3 seconds until a beep sounds.

Default Reset (All Settings):

When the pressure cooker is in standby mode, touch and hold the **Cancel** key for 2-3 seconds until a beep sounds.

Operational Field - Delay

The **Delay** setting can be applied to all Smart Programs with the exception of **Sauté**, **Manual Keep Warm**, and **Yogurt**. The **Delay** setting is not recommended to be used in conjunction with the auto-venting features when cooking thick or foamy foods. The liquid may cause spattering during the cooking process.

1 To set a **Delay** cook timer, touch the **Delay** field.



2 Once the 'Hour' field or 'Minute' field is flashing, the pressure cooker is ready to be customized.

Note: The delay start time will be based upon the clock.

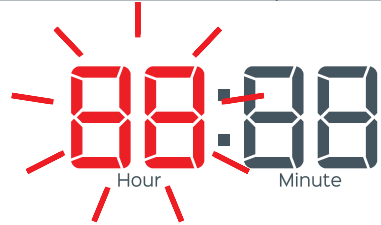

3 Touch the 'Hour' field and turn the central dial to select the desired hour value.

3 Touch the 'Minute' field and turn the central dial to select the desired minute value.

To adjust AM/PM, turn the central dial until the display rolls past 12:00.

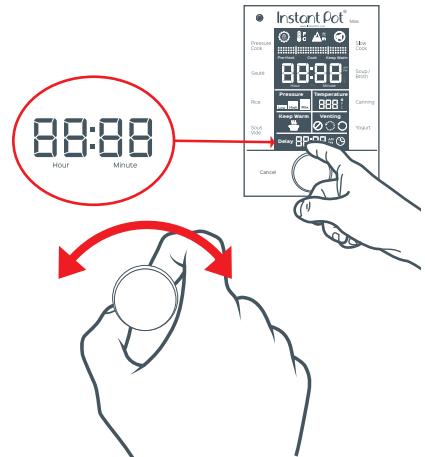

4 Touch **Start** to begin the **Delay** cooking process.

When the **Delay** function is active, a second hand will tick around the clock icon.

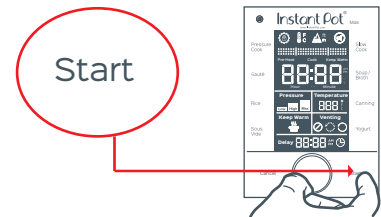

Operational Field - Keep Warm

Automatic **Keep Warm** can be applied to all Smart Programs with the exception of **Sauté**, **Sous Vide**, and **Yogurt**. When enabled, the setting will turn **ON** by itself after the Cook cycle has completed, and remain on for up to 10 hours. When selecting an applicable Smart Program, the **Keep Warm** setting will be **ON** by default. To turn it **OFF**, touch the Keep Warm icon.

- 1 To turn on Manual **Keep Warm** from Standby mode, touch the **Keep Warm** field.



- 2 Once the 'Hour' field is flashing, turn the central dial to select the desired hour value.
Touch the 'Minute' field and turn the central dial to select the desired minute value.

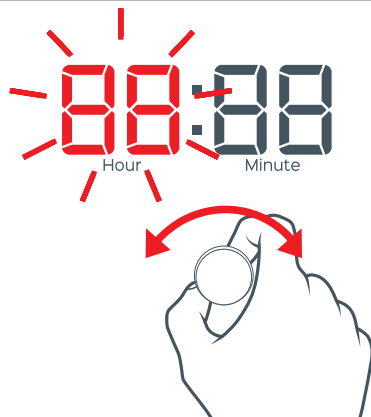

- 3 Touch the 'Temperature' field to toggle between "Low/High/Custom".
Custom Temperature: When "Cus" is flashing, turn the central dial to adjust the temperature up or down as desired.

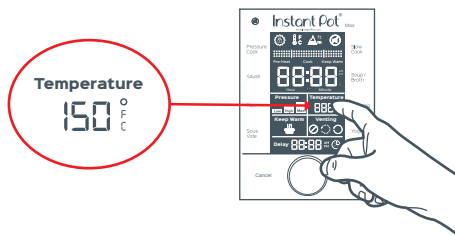

- 4 Touch **Start** to begin warming.
When **Keep Warm** is active, the steam symbols above the icon will blink one at a time.



Usage Tips



- For all pressure cooking programs **Pressure Cook, Rice, Soup/Broth,** and **Canning,** the total amount of pre-cooked food and liquid in the inner pot should not exceed the PC MAX— $2/3$.
- For food that expands during cooking, the inner pot should not be filled higher than the $-1/2$ line.
- Always ensure that the steam release valve, steam release cover, steam release pipe, anti-block shield, and float valve are clean and free of food particles and residue before cooking.
- The time it takes the pressure cooker to pressurize and depressurize will depend on a variety of factors. For this reason, the pre-heat cycle may take up to 40 minutes.
 - Frozen food will take a longer amount of time to pressurize.
- Recipes may indicate to use the **Manual** or the **Pressure Cook** function. These terms are interchangeable.
- After sautéing, remove ingredients and add $1/2$ cups (125mL / 4oz) of liquid to the inner pot. Gently scrape up the bits and pieces on the bottom and use this liquid to pressure cook with. Ensure to have $1 1/2$ cups (375mL / 12oz) of liquid in the inner pot before pressure cooking, unless otherwise directed by an authorized Instant Pot® recipe.



INSTANT TIP: Sweet & Savory Sealing Rings

Try using separate sealing rings for sweet and savory dishes!

Instant Pot® sealing rings are an integral part of product safety. Replace your sealing ring every 12-18 months, as it may become less effective over time.

Only use Instant Pot® genuine sealing rings, designed specifically for use in Instant Pot® smartcookers.

Visit www.store.instantpot.com to purchase.

Cooking Tips

- Certain food (such as applesauce, cranberries, pearl barley, oatmeal, split peas, noodles, etc.) can foam, froth, or spatter, and can clog the steam release pipe and/or steam release valve. Extreme caution must be used when cooking and venting these foods—the inner pot should not be filled higher than the – 1/2 line.
- When pressure cooking food with a doughy or thick texture, or a high fat/oil content, contents may spatter when opening the lid. Please follow recipe instructions for pressure release method. Once pressure is fully released, gently rock the cooker back and forth on its feet, then if necessary, release the steam again before removing the lid.
- There needs to be at least 1½ cups (375mL / 12oz) of liquid in the inner pot (unless otherwise specified in your recipe), so enough steam can be generated to pressurize the unit.
 - Acceptable liquids include water, broth, stock, wine, beer, fruit juice, vegetable juice, and thin cooking sauces. Cooking liquids must be water-based.
 - Oils and oil-based sauces do not have enough water content to bring the pressure cooker to pressure— avoid recipes that call for the use of more than ¼ cup of oil or fat content.
 - Thick sauces should be diluted, keeping in mind that some of the added liquid will be turned into steam for pressurization; sauces should be fairly thin in consistency before cooking begins.
- When cooking meat with skin (e.g. sausage with casing), the skin can swell when heated. Do not pierce the skin as long as it is swollen; this could result in scalding injury.
- When cooking Sous Vide, season lightly —a little goes a long way! Use less salt than you might normally, especially with meats, poultry, and fish. If your dish requires additional seasoning, salt to taste after cooking. Use garlic powder instead of fresh garlic or garlic salt.



INSTANT TIP: Making Changes Mid-Cooking



You can make changes during the Cook cycle of any Smart Program.

- 1 Touch the field you want to change: **Pressure**, **Temperature**, **Keep Warm**, or **Venting** and then make the adjustment by toggling to the correct setting.
- 2 Touch **Start** or wait 5 seconds for a beep to sound. The Cook cycle will resume.

Within the **Sauté**, **Yogurt**, and Manual **Keep Warm** Smart Programs, on-the-fly temperature changes are limited to Low and High options. To select and adjust a Custom setting, touch **Cancel**, then re-key in your desired cooking commands. In the **Temperature** field, you may toggle between **Low** and **High** freely, but you will not have the option to adjust to a Custom temperature setting. To select a Custom setting, touch **Cancel**, then re-key in your desired cooking commands.

Smart Program - Pressure Cook

The following pressure cooking programs are available: **Soup/Broth, Rice, Canning,** or **Pressure Cook.**

Steps to Pressure Cook

- 1 Add ingredients to the inner pot and insert the inner pot into the cooker base.
- 2 Place the lid on the cooker base and turn it clockwise to close it.
- 3 Connect the power cord. The LCD will display **OFF**, indicating that the pressure cooker is in standby mode.
- 4 Select the desired Smart Program: **Soup/Broth, Rice, Canning,** or **Pressure Cook.**
- 5 Touch the 'Hour' field to select it, then turn the central dial to adjust the time to the desired hour. Repeat the process to adjust the 'Minute' field. Does not apply to **Rice.**
- 6 Touch the **Pressure** field to toggle between Low, High, and Max pressure and select the desired pressure.
- 7 Touch the **Keep Warm** field to turn the setting **ON** or **OFF.**
- 8 Touch the **Venting** field to toggle between the venting options: NR, PR, QR, and select the desired venting method.
- 9 Touch **Start** to begin. The pressure cooker will beep 3 times.
- 10 Depending on the amount of food and its temperature, the Pre-Heat cycle may take up to 40 minutes. As the cooker heats up and pressure builds, the float valve will rise on its own. When working pressure is reached, the cooker will enter the Cook cycle and the LCD will display the remaining cooking time.
- 11 When cooking is finished, the pressure cooker will either remain in **Keep Warm** mode or standby mode displaying **OFF.**
- 12 The pressure will be released as selected in the **Venting** step: NR, PR, QR.
- 13 Ensure the float valve is down and the Pressure Indicator is **OFF** before opening the lid.

INSTANT TIP: Pressure Cook with the Steam Rack



When pressure cooking, use the steam rack to lift your food out of the cooking liquid. This will help distribute heat evenly and prevent the leeching of nutrients.

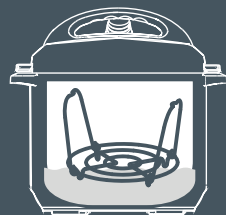

Advanced Feature - NutriBoost™

NutriBoost™ is a mid-cooking Pulse Release setting that may be activated on the **Rice** and **Soup/Broth** Smart Programs.

Rice: *NutriBoost™* occurs during the first 3 minutes of the "Cook" cycle.

Soup/Broth: *NutriBoost™* occurs during the last 15 minutes of the "Cook" cycle.

The boiling motion effect created by *NutriBoost™* helps to break down food— adding nutrients, enhancing flavors, and improving textures. This setting is ideal for bone broth or risotto.

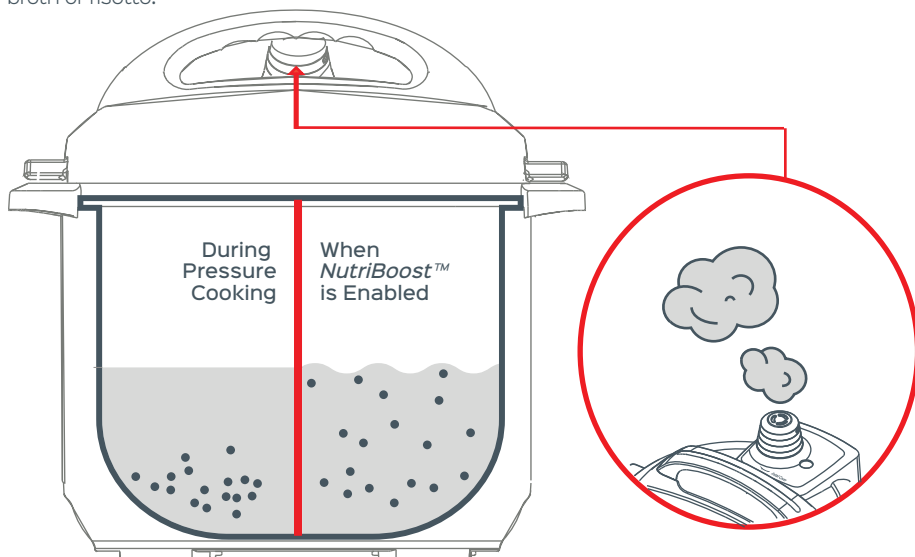

Steps to activating the *NutriBoost™* feature:

- 1 Follow "Steps to Pressure Cook" 1-3 outlined on the previous page.
- 2 Touch **Soup/Broth** or **Rice**.
- 3 Touch the 'Minute' field to select it, then turn the central dial to adjust the time as desired. Repeat the process to adjust the 'Hour' field.
- 4 Touch the **Pressure** field to toggle between Low, High, and Max. Select the desired setting.
- 5 Touch the **Venting** field and select PR to activate *NutriBoost™*.
- 6 Touch **Start** to begin. *NutriBoost™* is an automated setting and will activate automatically throughout the Cook cycle.

Note: Do not activate NutriBoost™ when cooking starchy and foamy food such as porridge, oatmeal, etc., to avoid spattering. This advanced venting feature should be closely monitored when cooking. Deactivate NutriBoost™ by touching the Venting field if you see food content coming out of the steam release cover.

Canning - Getting Started

Canning is a pressure cooking function based on traditional canning principles. When proper canning processes are followed and sufficient temperatures are reached for a sustained period of time, canning is considered an economical way to preserve quality food at home.

⚠️ CAUTION Recipes must be closely followed when canning. Modifying cooking times, ingredients or temperatures can be dangerous. Use the exact time, temperature/pressure and method specified in the recipe to protect the food from harmful bacteria, molds, and enzymes.

Read and carefully follow the instructions provided in the **USDA's Complete Guide to Home Canning**. http://nchfp.uga.edu/publications/publications_usda.html

The **Canning Smart** Program includes 2 settings:



Setting	Pressure	Time Range	Examples of Ingredients
Low	6.5 psi	00:01 - 08:00	High-acid fruit, fruit sauces, jams, chutney
Max	15 psi		Vegetarian sauces, high-acid vegetables Low-acid foods and meats; sauces and soups containing meat

Altitude: Water boils at lower temperatures as altitude increases. Lower temperatures are less effective for killing bacteria. Ensure the proper altitude level is set on the pressure cooker before starting to pressure can. Depending upon the altitude level setting, the pressure cooker will adjust the temperature and pressure accordingly.

⚠️ WARNING



Improper canning may cause preserves to spoil, which may result in illness. Do not pressure can at altitudes above 2000m (6600ft).

Refer to the USDA's Complete Guide to Home Canning for procedures and limitations:

http://nchfp.uga.edu/publications/publications_usda.html

Canning - Sterilizing Jars

All food used for canning should be poured into sterile, empty jars. Always check your jars, lids, and seals for chips and other imperfections. Sterilization of jars should occur just before filling. Excess contact with the air should be avoided for safe canning.

Steps to Sterilization Before Canning

- 1 Wash the jars and rinse thoroughly.
- 2 Ensure there are no cracks or imperfections in the jars or lids.
- 3 Place the inner pot into the cooker base, then place the steam rack on the bottom of the inner pot.
- 4 Place the jars on the steam rack. The pressure cooker will hold up to 4 x 16 oz. (500 mL) jars.
- 5 Fill the inner pot with 3 cups (750mL / 24oz) of warm water.
- 6 Place the lid on the cooker base and turn it clockwise to close it.
- 7 Connect the power cord to a 120V outlet. The cooker will enter standby mode.
- 8 Select **Canning**.
- 9 Touch the 'Minute' field to select it, then turn the central dial to adjust the time to 10 minutes. Ensure that the 'Hour' field displays '00', otherwise touch the 'Hour' field and turn the central dial until the display shows '00'. The display will read 00:10.
- 10 Touch the **Pressure** field to toggle between Low and Max pressure. Select Low Pressure. The display will read "Low".
- 11 Touch the **Venting** field to toggle between the venting options, and select QR.
- 12 Touch **Start** to begin. The pressure cooker will beep 3 times.

Note: Before selecting Start, the LCD will display the target temperature. Once Start has been selected, the LCD will display the real-time cooking temperature.



INSTANT TIP: What You'll Need for Canning

- Steam Rack
- Jars
- Lids, Seals & Bands
- Canning Tongs

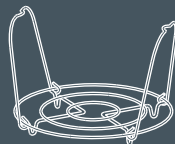

Canning - Pressure Canning

Steps to Pressure Canning

To begin, select a recipe that has been pre-tested and approved for pressure canning. Though ingredients may vary, the process will be the same.

Refer to the USDA's Complete Guide to Home Canning for tested recipes:

http://nchfp.uga.edu/publications/publications_usda.html

- 1 Fill warm, sterilized canning jars with food, following the directions in the recipe for required headspace.
- 2 Using a sterilized, flexible, nonporous spatula, gently press inward between the food and the jar to remove any trapped air bubbles.
- 3 Place a sterilized lid on top of the jar and then add a screw band. Turn clockwise and hand tighten in place. Do not over-tighten.
- 4 Place the inner pot into the cooker base, then put the steam rack at the bottom of the inner pot.
- 5 Place the filled and sealed jars on the steam rack. The pressure cooker will hold up to 4 x 16 oz. jars.

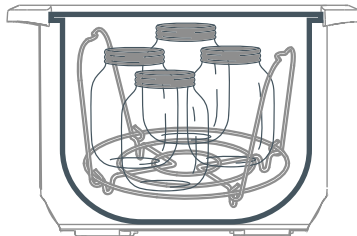

- 6 Pour hot water into the inner pot until the water level reaches $\frac{1}{4}$ of the way up the sides of the jars, approximately 6 cups (1½ L / 48 oz) of water.

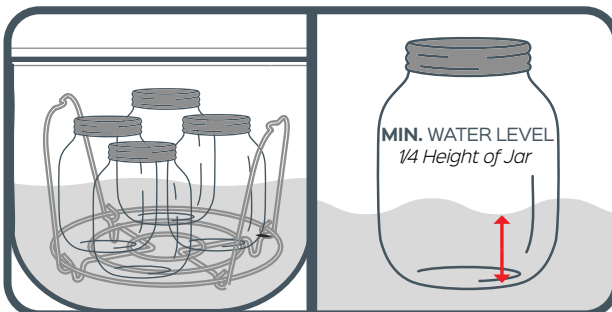

Canning - Pressure Canning

- 7 Place the lid on the cooker base and turn it clockwise to close it.
- 8 Connect the power cord to a 120V outlet. The cooker will enter standby mode.
- 9 Select **Canning**.
- 10 Touch the 'Minute' field to select it, then turn the central dial to adjust the time as determined by the recipe. Touch the 'Hour' field to select it, then turn the central dial to adjust the time as determined by the recipe.
- 11 Touch the **Pressure** field to toggle between Low and Max pressure, select desired pressure needed for your canning recipe. The display will read Low or Max depending upon the level selected.
- 12 Touch the **Venting** field to toggle between the venting options, and select the venting method required for your canning recipe.
- 13 Touch **Start** to begin. The pressure cooker will beep 3 times.
- 14 When the Cook time has counted down, the pressure cooker will beep 10 times to signal that the Smart Program has completed.
- 15 The pressure cooker will release pressure automatically using the method that was previously selected.
- 16 Open the lid by turning counter-clockwise and lifting. Ensure the float valve is down and the Pressure Indicator is **OFF** before opening the lid.
- 17 Using canning tongs and oven mitts, remove the hot jars and place them on a heat resistant surface and allow to cool to room temperature for 12 to 24 hours.

Note: Refer to the USDA's Complete Guide to Home Canning for information on testing the seals, storage, etc.

Smart Program - Sauté

Sauté is a non-pressure cooking program and works like a frying pan or flat-top grill — as a fantastic way to caramelize onions or sear meat before cooking.

Note: This Smart Program has a maximum set time of 30 minutes to prevent overheating. You may see the display switch between 'On' and 'Hot' — this is normal, and means that your element is working to maintain the temperature.

Steps to Sauté

- 1 Connect the power cord to a 120V outlet; the cooker will enter standby mode.
- 2 Select **Sauté**.
- 3 Touch the 'Minute' field to select it, then turn the central dial to adjust the time as determined by the recipe.
- 4 Touch the **Temperature** field to toggle between Low, High and Custom. If you would like to set a precise temperature, select Custom. The display will read "Cus"; turn the central dial to adjust the temperature.
- 5 The display will read "Hot" when the inner pot has reached the target temperature.
- 6 Add the ingredients to the inner pot and begin sautéing.
- 7 If the ingredients have been sautéed to the desired doneness before the time expires, simply touch **Cancel** to end **Sauté**.

Note: If you add food ingredients before the inner pot has reached the desired temperature, your display may never read 'Hot', but this doesn't mean you can't start cooking. To test if the inner pot has reached sizzling temperature, sprinkle a few drops of water into the inner pot. If it sizzles right away, you're ready to start! If not, give it another few minutes to heat up.

CAUTION

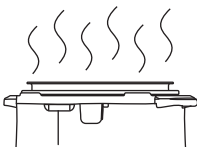

The **Sauté** Smart Program reaches high temperatures. If unmonitored, food may burn on this setting. To avoid burning, do not use the lid and do not leave your cooker unattended while using **Sauté**.

Smart Program - Slow Cook

Slow Cook is comparable to the cooking process of traditional slow cookers, heating to just below boiling over a long period of time. Dependent upon the desired cook time, you may select the appropriate temperature setting for your dish.

Low – For all-day cooking. It will maintain temperatures just below boiling until the Cook cycle has completed.

High – Provides faster cooking. It will maintain temperatures just below boiling until the Cook cycle has completed.

Steps to Slow Cook

- 1 Add ingredients to the inner pot and place the inner pot into the cooker base.
- 2 Place the lid on the cooker base. Do not lock the lid (Optional: use a glass lid for the best slow cooking results).
- 3 Connect the power cord to a 120V outlet. The cooker will enter standby mode.
- 4 Select **Slow Cook**.
- 5 Touch the 'Hour' field to select it, then turn the central dial to adjust the time as desired. Repeat the process to adjust the 'Minute' field if necessary.
- 6 Touch the **Temperature** field to toggle between Low and High.
- 7 Touch the **Keep Warm** field to turn the setting **ON** or **OFF**.
- 8 Touch **Start** to begin. The pressure cooker will beep 3 times.



INSTANT TIP: Instant Pot® Tempered Glass Lid

The glass lid is ideal for monitoring the cooking process while using the **Slow Cook** Smart Program.

Visit our online store for a full list of accessories:

www.store.instantpot.com



Smart Program - Sous Vide

The term “Sous Vide” is French for ‘Under Vacuum’ and refers to the process of vacuum sealing food, bringing it to a very accurate temperature, and maintaining that temperature for a period of time to achieve high quality, consistently delicious results.

Sous Vide offers a customizable setting which allows you to choose a cooking temperature from a range of 25°C ~ 90°C / 77°F ~ 194°F, ideal for Sous Vide cooking.

Steps to Sous Vide

- 1 Fill the inner pot $\frac{2}{3}$ full of water for optimal temperature control.
- 2 Insert the inner pot into the cooker base, then place the lid on the cooker base and turn it clockwise to close it.
- 3 Connect the power cord to a 120V outlet. The cooker will enter standby mode.
- 4 Select **Sous Vide**.
- 5 Touch the ‘Hour’ field to select it, then turn the central dial to adjust the time to desired hour value. Repeat the process to adjust the ‘Minute’ field.
- 6 Touch the **Temperature** field and use the central dial to increase or decrease the temperature.
- 7 Touch **Start** to begin. The pressure cooker will beep 3 times.
- 8 While the pressure cooker heats, season your food as desired, then place the ingredients into airtight pouches. Separate single servings of food within individual pouches. Remove air from the pouches and seal tightly.
- 9 Once the set water temperature has been reached the pressure cooker will beep. Open the lid and immerse the sealed pouches into the inner pot. The contents of the pouches should be submerged below the water level.

Smart Program - Sous Vide

- 10 Place the lid on the cooker base and turn clockwise to close.
- 11 For long cooking times, check periodically to make sure the water level remains above the sealed pouches. If you need to add water, heat it to approximately the same temperature as the water in the container to avoid cooling the water.
- 12 Once the Cook cycle has completed, use the **Sauté** Smart Program, a pan, browning torch, or barbecue to sear meat to your preference.



INSTANT TIP: What You'll Need for Sous Vide

- Airtight or Vacuum-Sealed Food Pouches
- Tongs
- Optional: Vacuum sealer



Sous Vide - Cooking Guidelines

Food	Thickness	Cooking Outcome	Cooking Temperature	Cooking Time (Minimum)	Cooking Time (Maximum)
Beef					
Tender Cuts:					
Tenderloin, cutlets, sirloin, rib eye, rump, T-bone	2-5 cm / ½" - 2"	Rare	50 °C / 122 °F	1 hour	4 hours
		Medium rare	54 °C / 129 °F	1 hour	4 hours
		Medium	56 °C / 133 °F	1 hour	4 hours
		Well done	60 °C / 140 °F	1 hour	4 hours
Tougher Cuts:					
Blade, chuck, shoulder, shanks, game meats	4-6 cm / 1½" - 2½"		50 °C / 122 °F	8 hours	18 hours
Pork					
Belly	3-6 cm / 1" - 2½"		82 °C / 180 °F	10 hours	22 hours
Ribs	2-3 cm / ½" - 1½"		59 °C / 138 °F	10 hours	22 hours
Chops	2-4 cm / ½" - 2"		56 °C / 133 °F	2 hours	10 hours
Lamb					
Chops	2-4 cm / ½" - 2"	Rare	52 °C / 126 °F	1 hour	3 hours
		Medium rare	55 °C / 131 °F	2 hours	5 hours
		Medium	60 °C / 140 °F	1 hour	4 hours
Poultry					
Chicken:					
- breast with bone	3-5 cm / 1" - 2"		82 °C / 180 °F	2 hours	7 hours
- breast without bone	3-5 cm / 1" - 2"		64 °C / 146 °F	1 hour	5 hours
- thigh with bone	3-5 cm / 1" - 2"		82 °C / 180 °F	2 hours	7 hours
- thigh without bone	3-5 cm / 1" - 2"		64 °C / 146 °F	1 hour	4 hours
- legs	5-7 cm / 2 - 3"		82 °C / 180 °F	2 hours	7 hours
Duck Breast	3-5 cm / 1" - 2"		64 °C / 146 °F	2 hours	4 hours
Fish & Seafood					
Fish	2-3 cm / ½" - 1"	Very rare, firm	43 °C / 110 °F	20 mins	45 mins
		Rare, moist	46 °C / 115 °F	20 mins	45 mins
		Medium, dry	49 °C / 120 °F	20 mins	45 mins
		Well Done, crumbly	54 °C / 130 °F	20 mins	45 mins
Shrimp			60 °C / 140 °F	15 mins	1 hour
Lobster Tail			60 °C / 140 °F	20 mins	1 hour
Scallops			60 °C / 140 °F	30 mins	30 mins
Eggs					
		Runny	60 °C / 140 °F	45 mins	
		Soft boiled	63 °C / 145 °F	45 mins	
		Medium boiled	68 °C / 155 °F	45 mins	
		Hard boiled	74 °C / 165 °F	45 mins	
Fruit & Vegetables					
Vegetables			85 °C / 185 °F	1 hour	3 hours
Fruits			85 °C / 185 °F	45 mins	2 hours

Smart Program - Yogurt

Yogurt is a non-pressure cooking function with 3 settings: Boil, Yogurt, and Custom. The Custom setting will allow users to make different types of customized fermented dairy and non-dairy recipes.

Steps to Making Yogurt - *fresh, dairy-based yogurt*

1 Pasteurization

- a. Add milk to the inner pot. Place the lid on the cooker base and turn it clockwise to close it.
- b. Connect the power cord to a 120V outlet. The cooker will enter standby mode.
- c. Select **Yogurt**.
- d. Touch the **Temperature** field to toggle between Boil, Yogurt, and Custom. Select Boil.
- e. Touch **Start** to begin.
- f. Milk must reach a minimum of 161°F (71°C) for pasteurization to occur.

2 Adding Culture

- a. Remove the lid and allow it to cool to just below 110°F (43°C). To speed up the cool down process, remove the inner pot and place it on a wire rack.
- b. Add the starter culture as indicated by the starter culture instructions.

3 Fermentation

- a. Place the lid on the cooker base and turn it clockwise to close it.
- b. Select **Yogurt**.
- c. Touch the **Temperature** field to toggle between Boil, Yogurt, and Custom. Select Yogurt.
- d. The Yogurt temperature setting will default to 8 hours. Touch the 'Hours' field and turn the central dial to adjust. The longer the fermentation, the tangier the yogurt will taste. If you wish to customize both the fermentation time and temperature, select Custom.
- e. Touch **Start** to begin.



INSTANT TIP: What You'll Need to Make Yogurt

- Thermometer
- Milk
- Active yogurt culture

Visit our online store for single serve yogurt cups that hold up under pressure.

www.store.instantpot.com



Care & Cleaning

- Wash all parts and accessories after use
- Never use harsh chemical detergents, scouring pads, or powders on any of the unit's parts or components

Part	Cleaning Method			Cleaning Tip
	Dishwasher Safe	Hand Wash (submerged)	Wipe Clean (damp cloth)	
Accessories <ul style="list-style-type: none"> • steam rack • soup spoon • rice paddle • rice measuring cup • silicone mini mitts 				<ul style="list-style-type: none"> • For dishwasher place in top rack
Small Parts <ul style="list-style-type: none"> • anti-block shield • sealing ring • steam release valve cover • steam release valve • float valve • float valve silicone cap • condensation collector 				<ul style="list-style-type: none"> • All small parts should be removed once every few cooking cycles for routine cleaning, and any time there is visible food debris • Store sealing rings in a well ventilated area to decrease the residual odor of flavorful meals. To eliminate odors from the sealing ring, add 1 cup (250 mL) water and 1 cup (250 mL) white vinegar to the inner pot, and run Pressure Cook for 5-10 minutes, then QR pressure
Detachable Cord				<ul style="list-style-type: none"> • Do not clean the prongs of the detachable cord • Do not submerge the detachable cord in water
Inner Pot				<ul style="list-style-type: none"> • More acute hard water staining may require a vinegar dampened sponge and some scrubbing to remove • If there is tough or burned food residue at the bottom, soak in hot water for a few hours for easy cleaning
Lid				<ul style="list-style-type: none"> • Remove all small parts before dishwashing • Wash with hot water and mild dish soap and allow to air dry • To drain water from the lid after dishwashing, grasp the lid handle and hold the lid vertically over a sink, then turn it 360°—such as turning a steering wheel
Cooker Base				<ul style="list-style-type: none"> • Wipe the condensation collecting rim and empty the condensation collector after each use



Ensure the heating element remains dry at all times.

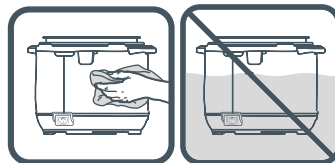

DO NOT immerse the cooker base in water or attempt to cycle through dishwasher.

Troubleshooting

The topics covered in the following table do not always indicate a faulty cooker. Please examine the cooker carefully. If you require support, contact the Customer Care Team:

- Create a Ticket: www.support.instantpot.com
- Live Chat: www.instantpot.com/#Chat
- Email: support@instantpot.com
- Call: 1-800-828-7280
- Tips, videos, and FAQs: www.InstantPot.com

Instant Pot® parts and accessories are available on our online store: www.store.instantpot.com

Register your Instant Brands™ appliance here: www.instantpot.com/support/register

Problem	Possible Reason	Solution
Difficulty closing the lid	Sealing ring not seated properly	Adjust sealing ring, ensure it is fully seated behind ring rack
	Float valve stuck in popped-up position	Gently press the float valve down
	Contents in cooker are still heated	Lower lid onto cooker base slowly, allowing heat to dissipate
Difficulty opening the lid	Cooker is still under pressure	Touch Venting field, select NR. If pressure has not fully released after 60 minutes; contact the Customer Care Team
	Float valve stuck in popped-up position	Ensure the pressure has released fully
Lid is stuck to inner pot	Cooling of inner pot may create suction, causing inner pot to adhere to the lid	To release the vacuum, touch the Venting field to toggle to QR
Steam leaks from side of lid	No sealing ring in lid	Install the sealing ring
	Sealing ring damaged	Replace the sealing ring
	Ring rack is warped or off-centre	Remove the sealing ring and check for this. Contact the Customer Care Team
	Food particles attached to ring	Clean the sealing ring
	Lid not closed properly	Open then close the lid again
	Inner pot rim may be misshapen	Check for deformation and contact the Customer Care Team

Troubleshooting

Problem	Possible Reason	Solution
Float valve does not rise	Food debris on float valve or surrounding area	Remove float valve from lid, clean float valve, silicone cap, and surrounding area on lid
	Float valve silicone cap worn out	Replace the float valve
	Too little liquid in inner pot	Add requisite minimum 1½ cups (375mL / 12oz) of a thin liquid to inner pot
	Float valve obstructed by lid-locking mechanism	Open and close the lid completely
	No heat in the inner pot / Inner pot base may be damaged	Ensure inner pot is flush with heating element; perform "Initial Test Run" to check for function; contact the Customer Care Team
No power to unit	Bad power connection or no power	Ensure detachable power cord is plugged tightly into base power socket. Try the cooker on other outlets
	Cooker's electrical fuse has blown	Contact the Customer Care Team
Occasional clicking or light cracking sound	Expanding pressure board under changing temperatures	This is normal. The clicking sound is the result of the power relay working
	Bottom of inner pot is wet	Wipe bottom side of inner pot before placing on element
Minor steam leaking/hissing from steam release valve during Cook cycle	Regulating excess pressure Cook cycle	This is normal
On-Screen Self-Diagnostic	The word " Lid " is displayed because lid is not used properly	Make sure the lid is closed properly. Do not use the lid during the Sauté Smart Program
	The words " Food burn " is displayed because food is burnt	Stir food to avoid burning and add water as necessary
	The word " noPr " is displayed because there is not enough pressure	Add a minimum 1½ cups (375 mL / 12oz) of a thin liquid to the inner pot
	The word " PrSE " is displayed because of excess pressure	Press the Cancel key and allow the cooker to cool for 60 minutes. Contact the Customer Care Team if pressure is not fully released
	The word " Alt " is displayed because the target temperature on Canning was not reached, or the altitude setting is incorrect.	Press the Cancel key. Confirm your current altitude and input the correct values on the cooker. Restart cooking

Troubleshooting

Problem	Possible Reason	Solution
Steam gushes from steam release valve when venting is not activated	Steam release valve not seated properly	Remove steam release cover and steam release valve, check for internal food debris; re-seat parts
	Too little liquid in inner pot	Add requisite minimum 1½ cups (375mL / 12oz) of a thin liquid to inner pot
	Pressure sensor control failure	Contact the Customer Care Team
Lights flash and error code appears on screen	C5: Inner pot is not seated properly	Remove and reposition inner pot in cooker base
		Add a higher volume of food and water to the inner pot
Lights flash and error code appears on screen	C1, C2, C6, C6H, C6L, E1, E2, E5, E6, E11, E12, E13, E14, E15, E16, E17, E18, and E19	Contact the Customer Care Team

Warranty

Limited Warranty

This Limited Warranty is effective for one year from the date of original consumer purchase. Proof of original purchase date and, if requested by an authorized representative of Instant Brands Inc. ("Instant Brands"), return of your appliance, is required to obtain service under this Limited Warranty. Provided that this appliance is operated and maintained in accordance with written instructions attached to or furnished with the appliance, Instant Brands will, in its sole and exclusive discretion, either: (i) repair defects in materials or workmanship; or (ii) replace the appliance. In the event that your appliance is replaced, the Limited Warranty on the replacement appliance will expire 12 months from the date of original consumer purchase.

This Limited Warranty extends only to the original purchaser and use of the appliance in the United States of America and Canada. This warranty does not cover units that are used outside of the United States of America and Canada.

Any modification or attempted modification to your appliance may interfere with the safe operation of the appliance and will void this Limited Warranty. This Limited Warranty does not apply in respect of any appliance or any part thereof that has been altered or modified unless such alterations or modifications were expressly authorized by an Instant Brands representative.

Limitation and Exclusions

The liability of Instant Brands, if any, for any allegedly defective appliance or part shall in no circumstances exceed the purchase price of a comparable replacement appliance.

This Limited Warranty does not cover:

1. Damage resulting from accident, alteration, misuse, abuse, neglect, unreasonable use, use contrary to the operating instructions, normal wear and tear, commercial use, improper assembly, disassembly, failure to provide reasonable and necessary maintenance, fire, flood, acts of God or repair by anyone unless directed by an Instant Brands Representative;
2. Repairs where your appliance is used for other than normal, personal use or when it is used in a manner that is contrary to published user or operator instructions; or
3. Use of unauthorized parts and accessories, or repairs to parts and systems resulting from unauthorized repairs or modifications made to this appliance.

The cost of repair or replacement under these excluded circumstances shall be borne by you.

Warranty

Disclaimer of Implied Warranties

EXCEPT AS EXPRESSLY PROVIDED HEREIN AND TO THE EXTENT PERMITTED BY LAW, INSTANT BRANDS MAKES NO WARRANTIES, CONDITIONS OR REPRESENTATIONS, EXPRESS OR IMPLIED, BY STATUTE, USAGE, CUSTOM OF TRADE OR OTHERWISE WITH RESPECT TO THE APPLIANCES OR PARTS COVERED BY THIS WARRANTY, INCLUDING BUT NOT LIMITED TO, WARRANTIES, CONDITIONS, OR REPRESENTATIONS OF WORKMANSHIP, MERCHANTABILITY, MERCHANTABILITY QUALITY, FITNESS FOR A PARTICULAR PURPOSE OR DURABILITY.

Some states or provinces do not allow for the exclusion of implied warranties of merchantability or fitness, so this limitation may not apply to you. In these states and provinces, you have only the implied warranties that are expressly required to be provided in accordance with applicable law.

Limitation of Remedies; Exclusion of Incidental and Consequential Damage

YOUR SOLE AND EXCLUSIVE REMEDY UNDER THIS LIMITED WARRANTY SHALL BE APPLIANCE REPAIR OR REPLACEMENT AS PROVIDED HEREIN. INSTANT BRANDS SHALL NOT BE LIABLE FOR INDIRECT, INCIDENTAL OR CONSEQUENTIAL DAMAGES ARISING OUT OF OR IN CONNECTION WITH THE USE OR PERFORMANCE OF THE APPLIANCE OR DAMAGES WITH RESPECT TO ANY ECONOMIC LOSS, PERSONAL INJURY, LOSS OF PROPERTY, LOSS OF REVENUES OR PROFITS, LOSS OF ENJOYMENT OR USE, COSTS OF REMOVAL, INSTALLATION OR OTHER INDIRECT, INCIDENTAL OR CONSEQUENTIAL DAMAGES OF ANY NATURE OR KIND.

Warranty Registration

Please visit <https://instantpot.com/support/register/> to register your new Instant Brands™ appliance and validate your warranty within thirty (30) days of purchase. You will be asked to provide the store name, date of purchase, model number (found on the back of your appliance) and serial number (found on the bottom of your appliance) along with your name and email address. The registration will enable us to keep you up to date with product developments, recipes and contact you in the unlikely event of a product safety notification. By registering, you acknowledge that you have read and understand the instructions for use, and warnings set forth in the accompanying instructions.

Warranty Service

To obtain service under this warranty, please contact our Customer Service Department by phone at 1-800-828-7280 or by email to Support@InstantPot.com. You can also create a support ticket online at www.Support.InstantPot.com. If we are unable to resolve the problem, you may be asked to send your appliance to the Service Department for quality inspection. Instant Brands is not responsible for shipping costs related to warranty service, save and except for shipping costs associated with the return of your appliance from Canada or within the 48 contiguous states and the District of Columbia of the United States of America, as provided herein. When returning your appliance, please include your name, mailing address, email address, phone number, and proof of the original purchase date as well as a description of the problem you are encountering with the appliance.

Index

A

Acceptable Liquids	18
Adding Culture	28
Adjust Altitude	12, 16, 24
Anti-Block Shield	2, 7, 10, 29

B

Base Power Socket	8, 31
-------------------	-------

C

Canning – Sterilizing Jars	2, 22
Celsius to Fahrenheit	16
Central Dial	8, 12
Clock / Set Local Time	12, 16
Condensation Collector	6, 9
Condensation Collector Tabs	9
Condensation Drain Hole	8
Control Panel	12
Cooker Base	6, 8, 9, 10, 11, 29
Cooker Handles	2, 8
Cooking and Local Time Display	16
Cooking Progress Indicator	12
Customer Care Team	30

D

Deglaze	24, 31
Delay Start	12, 17
Detachable Power Cord	3, 5, 6, 11, 31
Dimensions	5

E

Error Code	31
------------	----

F

Factory Reset (All Settings)	16
Factory Reset (Specific Smart Programs)	16
Fermentation	28
Fill Level Indicators	18
Float Valve	2, 3, 7, 15, 29, 30, 31
Food Pouches	26

G

Glass Lid	25
-----------	----

H

Headspace	21
Heating Element	3, 8, 11

I

Important Safeguards	2-4
Initial Test Run	14, 15
Inner Pot	3, 6, 11, 18

K

Keep Warm Program	12, 16
-------------------	--------

L

LCD Touch Screen	8, 12
Lid	6, 7
Lid Fins	7, 8
Lid Handle	7
Lid Locking Pin	7
Lid Position Markers	7, 9
Limited Warranty	32, 33
Low Pressure Canning	22

M

Manual	6
Max Pressure Canning	21, 22, 23
Model	5

N

Natural Release	13
NutriBoost™	20

P

Pasteurization	28
Pressure Indicator	12, 15
Pressure Level Field	12
Pulse Release	13

Q

Quick Release	13
Quick Start Guide	6

R

Rating Label	9
Recipe Book	6
Rice Measuring Cup	6
Rice Paddle	6

S

Sealing Ring Rack	7, 11
Silicone Mini Mitts	6, 29
Silicone Sealing Ring	4, 6, 7, 11, 18, 29, 30
Smart Program Keys	12
Sound On / Off	12
Soup Spoon	6
Sous Vide	26, 27
Stainless Steel Outer Pot	8
Start Program Key	12
Steam Rack with Handles	6
Steam Release Pipe	7, 10
Steam Release Valve	7, 10
System Settings	12

T

Temperature Field	12
Temperature Sensor	7
Troubleshooting	30, 31

V

Venting Methods	13
Venting Fields	12
Venting System	10
Voltage	5

W

Warranty	32, 33
Water Test	14-15
Wattage	5
Weight	5

Y

Yogurt	28
--------	----

Instant Pot®

The Instant Pot® Products



Lux
3, 6, 8 Quart

Duo
3, 6, 8 Quart

Max
6 Quart

Duo Plus
3, 6, 8 Quart

Ultra
3, 6, 8 Quart

Tools for a New Lifestyle

Instant Pot®

Instant Brands Inc.
11 - 300 Earl Grey Drive Suite 383
Ottawa, Ontario
K2T 1C1
Canada

Telephone: 1-800-828-7280
Web: www.instantpot.com
Store: www.Store.InstantPot.com
US & Canada Email: support@instantpot.com

Download Free Recipe App below:



Join the Official Instant Pot Community:

facebook.com/groups/instantpotcommunity



@instantpot



@theinstantpot



@instantpotofficial



@instantpot



@instantpot

Copyright © 2018 Instant Brands™ Inc.