

Motorcycle Dash-cam

D10 Series User Manual



FHD Dual Camera



Sony IMX307



Night Vision



Tilt Angle



Park Guard



Altitude Pressure



IP67 Waterproof



Tire Pressure



Explore the world on two wheels with Deepmoto

Your trusted companion for all your motorcycle adventures

CONTENTS

▶ Safety Instructions for Use	4
▶ Dash-cam D10 Series Features	6
▶ Accessories	10
▶ Installation Guide	13
1. Pre-installation Preparation	13
2. Installation	13
▶ Function Introduction	18
1. Dash-cam Buttons and Operation Introduction	18
2. Dash-cam Interface Introduction	20
3. Menu Interface and Function Introduction	23
▶ Tire Pressure Installation And Function Introduction	29
1. Install the Tire Pressure Sensor	29
2. Tire Pressure Equipment Matching Function	30
▶ App Function Introduction	32
1. App Introduction	32
2. App Installation Method	32
3. App WiFi Connection	33
4. App Function Introduction	34
5. System Upgrade	37
▶ FAQ Guide	38
1. Dash-cam Host-related Issues	38
2. Camera and Video Related Issues	38
3. Application and WiFi Related Issues	39
▶ Product Parameters	40

- 1 The installation of this product requires a certain amount of hands-on ability. If the customer is not good at installing it by himself, it is recommended to go to the local car dealership and seek professional guidance for installation.
- 2 Please turn off the power of the motorcycle before installation, and restart the motorcycle after the installation is completed.
- 3 The motorcycle power box needs to be opened during installation, please prepare the corresponding tools by yourself.
- 4 The installation process is not complicated, please check the installation guide carefully and connect each accessory with the dash-cam.
- 5 Motorcycle models are different. Customers can choose a suitable location to install the host, camera, remote, power source, and GPS modules according to their own models. When installing, please pay attention to the socket of the cable, and do not use too much force to damage the interface. Please arrange the wiring reasonably, do not squeeze or fold, so as not to damage the cable.
- 6 When installing GPS, try to avoid installing it in a place surrounded by metal, which may affect GPS signal reception.
- 7 The camera is fully sealed and waterproof. Avoid using solvents such as alcohol and asphalt cleaning agent to contact the lens, so as not to damage the waterproof layer.
- 8 Do not wash the dash-cam with a high-pressure water gun for a long time to prevent water from entering the host.
- 9 When the dash-cam is turned on, do not insert or remove the TF card to avoid damage to the TF card.

- 10 Do not cut off the power when the system firmware is being upgraded online.
- 11 The safety voltage of this dash-cam is 36V, which can be applied to all motorcycle types (usually the voltage of the motorcycle battery is 12V). However, for some electric motorcycles, the battery voltage is as high as 60V or more, which has exceeded the voltage of the dash-cam, and may burn out the dash-cam host. If it is to be installed and used on an electric motorcycle, a voltage converter is required.

If you have any questions, please send email to us, we will answer you in time.
Customer service email: Deepmotoservice@163.com

Dash-cam D10 Series Features

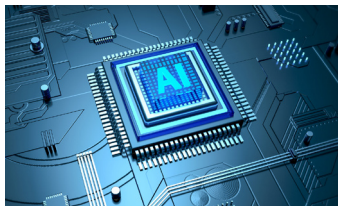

Cortex A7 Dual-core Intelligent Chip

With stronger performance and lower power consumption, brings you a more enjoyable user experience.

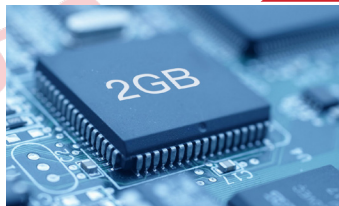

2GB High-capacity RAM

Makes your device run more smoothly, enabling you to enjoy an efficient user experience.



Connect The ACC Power Supply To Keep the Video Recording Synchronization At All Times



Support Up to 256GB TF Card

Allowing you to record any content you want and store more precious memories.



Front and Rear Dual Cameras



Full HD 1080P/30 Frames

Chip

Dash-cam D10 Series Features

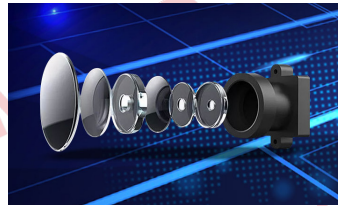

6 Glass Optical Lens + IR Filter

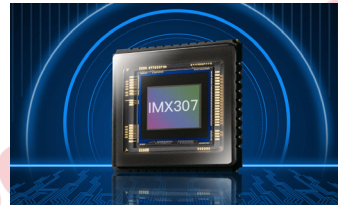

Sony IMX307 Image Sensor

Self-bandwidth dynamic technology, backlight display is clearer.



F1.6 Large Aperture



Starlight Night Vision



150° Wide Angle



EIS Electronic Image Stabilization

Camera

Dash-cam D10 Series Features



All Metal Material

Elegant design, black body, red logo, durable, better heat dissipation, better quality.



Easy To Install

Suitable for all models, non-destructive installation, two options are available (non-rotatable and rotatable).

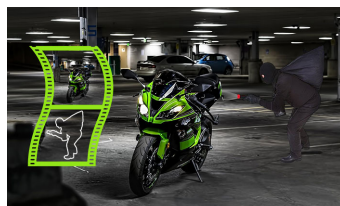

Parking Guard

Intelligent monitoring, guarding your car anytime, anywhere.



3-inch IPS Full-view High-definition Screen

The screen is more high-definition and the picture quality is more delicate.



IP67 Deep Waterproof

Protect you without fear of wind and rain.



Loop Recording

Loop protection, never offline, always record the wonderful moments of riding.

Dash-cam Host

Dash-cam D10 Series Features



Bending Warning

Monitor the motorcycle's inclination angle, speeding around the curve, and escort for safety.

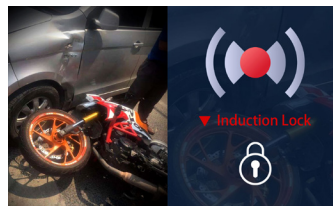

Vibration Sensor

Monitor the vibration, automatically lock the video when the collision occurs (automatic operation of the machine).



Altitude Air Pressure

Control field information anytime, anywhere.

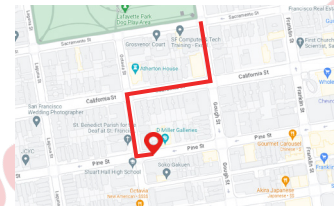

GPS Track Playback

Record every footprint and every moment of your motorcycle trip.

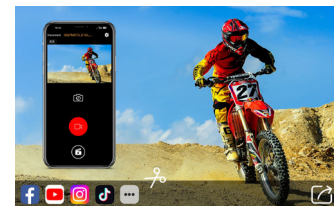

Exclusive APP

Download videos, edit them easily, and share them with one click.



Tire Pressure Monitoring

Tire temperature and pressure monitoring, real-time display. (Only D10PLUS has this function)



Dash-cam D10Plus



Only D10Plus is equipped with this device.

Power Supply



GPS Modules



ACC Detection Wire



Tire Pressure Installation Tool

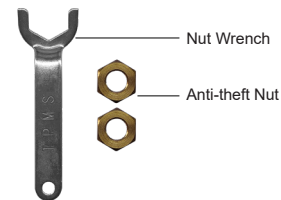

Only D10Plus comes with this tool kit.

Front Camera



Rear Camera



Dash-cam Fixed Support

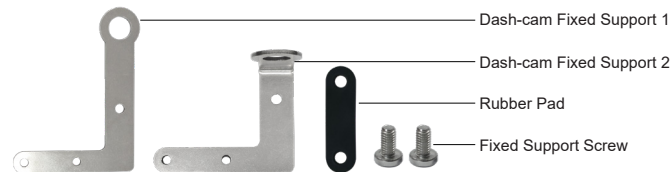

Camera Bracket

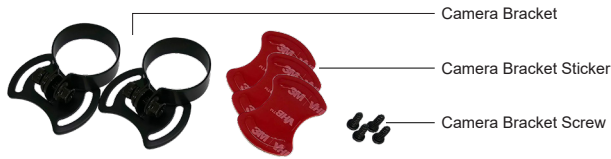

Heat Shrink Tubing

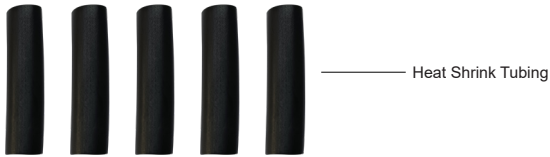

Installation Tools

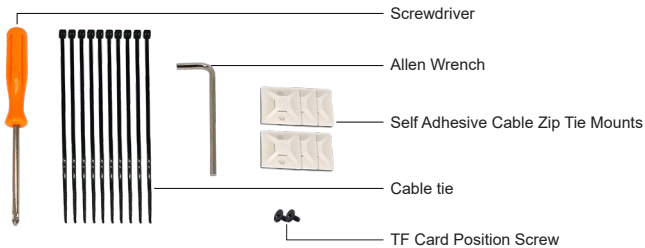

DEEPMOTO
D10 Series

Installation Guide

1. Pre-installation Preparation

- ▶ Please carefully check each package to confirm that all accessories are complete.
- ▶ Before installation, please turn off the motorcycle power and then turn it on after the installation is completed.
- ▶ Prepare the necessary tools to disassemble the motorcycle.
- ▶ Customers can choose a suitable location to install the main unit and accessories based on their motorcycle model. If customers are not skilled at installing the equipment themselves, they can consult with professionals at local motorcycle shops for guidance on installation.

2. Installation

2.1 Install the Dash-cam

Take out the accessories of **Dash-cam Fixed Support**, choose one of the **Dash-cam Fixed Support** place a **Rubber Pad** on it, and fix the dash-cam in the appropriate position at the front of the motorcycle. Which **Dash-cam Fixed Support** to use can be decided based on the desired installation position.



2.2 Install the Front Camera and Rear Camera

Take out the Cameras, and take out the Installation Tools.

Insert the **Front Camera** (shorter wire) into the **Camera Bracket**, and install it in the front of the motorcycle. The triangle symbol  on the camera represents the forward direction. The bottom of the camera bracket can be fixed with stickers.

If you are concerned about the stability of the bracket, screws can be added on both sides of the bracket, but this may damage the appearance of the motorcycle, so please choose carefully. It is recommended to use stickers to fix the bracket.

The installation method for the rear camera is the same as the front camera. After installation, connect the wires of the front and rear cameras to the Dash-cam.

 Installation Diagram

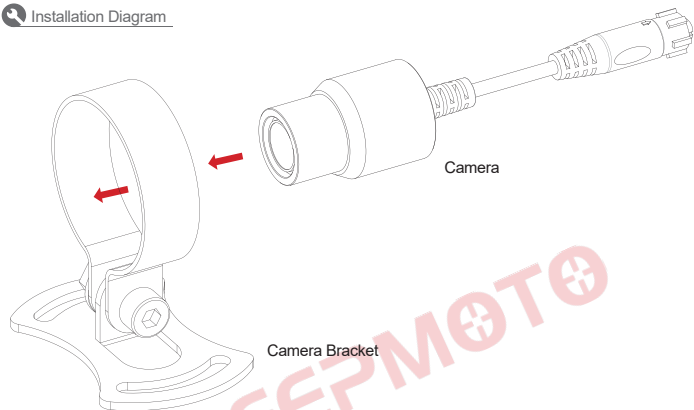

Use heat shrink tubing to further enhance waterproofing.

The heat shrink tubing in the accessory bag can be put on the connection between the lens and the host. After heating, the heat-shrinkable sleeve will shrink and stick to the joint, which can further enhance the waterproof effect.

Front camera real picture display



Rear camera real picture display



2.3 Install the Dash-cam Power Supply

Take out the **Dash-cam Power Supply**. The power supply has an output port and an input port.

The output port has two wires, the blue wire is connected to the GPS and the red wire is connected to the dash-cam.

The input port has three wires, colored red (positive), black (negative), and yellow (ACC). Connect the red and black wires to the positive and negative terminals of the motorcycle, respectively. Connect the yellow wire to the ACC in the motorcycle fuse box.

How to find out which one is the ACC wire in the motorcycle fuse box?

Customer can use the auxiliary tool ---- **ACC Detection Wire**

Take out the ACC detection wire, wrap the black wire around the metal body of the motorcycle, and use the red wire to touch the metal on top of the fuse.

After the motorcycle is powered on, if the LED light on the ACC detection wire lights up, turn off the motorcycle. If the LED light goes out, then the fuse you tested is the ACC wire for your motorcycle.

2.4 Install the GPS Modules

Take out the **GPS Modules** and connect it to the **Dash-cam Power Supply**.

After installation, start the motorcycle, and the Dash-cam will automatically turn on and enter the recording interface.

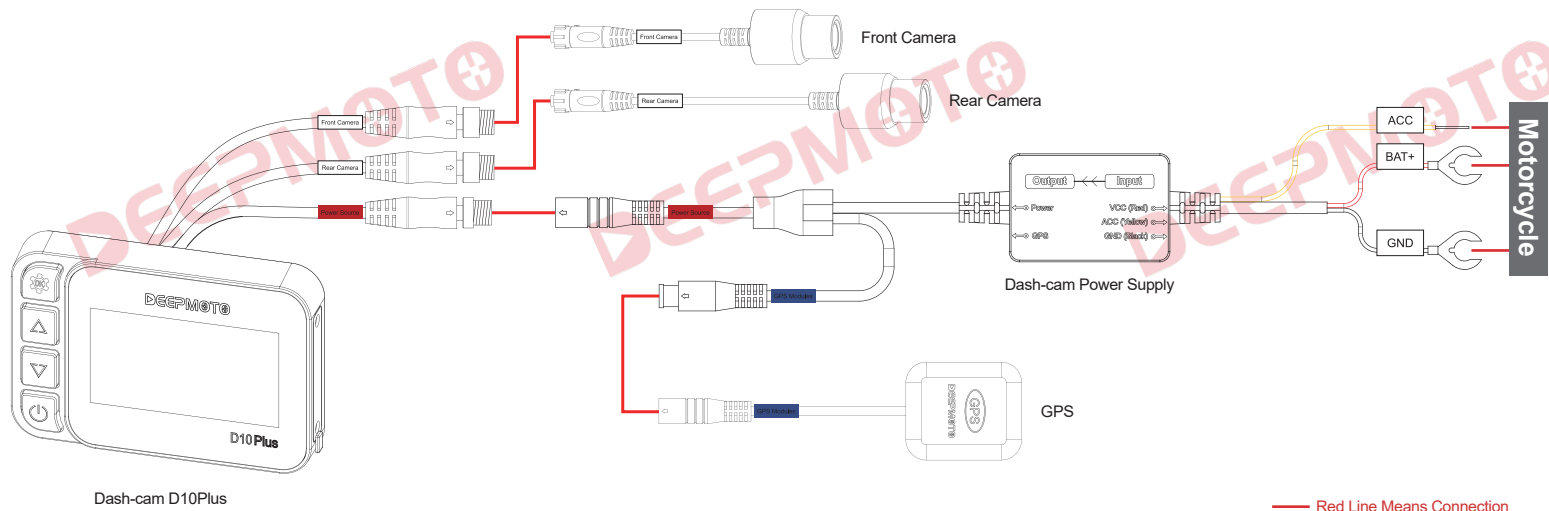

1. Dash-cam Buttons and Operation Introduction



1.1 Menu Key

- ▶ In the **Recording Interface**, short press is to enter the menu function interface, and long press is to turn on/off WiFi.
- ▶ In the **Menu Function Interface**, short press is to confirm, and long press is to return to the recording interface.
- ▶ In the **Video Management Interface**, short press is to play the video, and long press is to return to the recording interface.

1.2 UP Key

- ▶ In the **Recording Interface**, short press is to switch the monitoring screen of the front and rear camera.
- ▶ In the **Menu Function Interface**, short press is to move up the option.
- ▶ In the **Video Management Interface**, short press is to move up the option, long press is to delete the video, (a deletion prompt box will pop up for confirmation).

1.3 Down Key

- ▶ In the **Recording Interface**, short press to enter the video playback interface.
- ▶ In the **Menu Function Interface**, short press is to move down the option.
- ▶ In the **Video Management Interface**, short press is to move down the option, and long press is to lock/unlock the video file.

1.4 Power Key

- ▶ In the **Recording Interface**, short press is to enter the HUD interface, and long press to shut down the dash-cam.
- ▶ In the **Menu Function Interface**, short press is to switch the video recording of the front camera/rear camera.
- ▶ In the **Video Management Interface**, short press is to switch the video recording of the front camera/rear camera.
- ▶ In the **HUD Interface**, short press is to return to the recording interface.

1.5 TYPE-C

- ▶ This port is used by engineers for testing.

1.6 TF Card Slot

- ▶ The video can be recorded normally only after inserting the TF card in this position.
- ▶ Customers need to purchase TF card by themselves, this product does not include TF card.

2. Dash-cam Interface Introduction

2.1 Recording Interface (Video Monitoring Interface)

- ▶ The recording interface is to display the monitoring screen captured by the camera in real time. After the motorcycle is turned on, it will automatically enter the recording interface.
- ▶ When the WiFi and GPS are successfully connected, the color of the icon will change from white to green.

Recording Interface Icon Introduction:

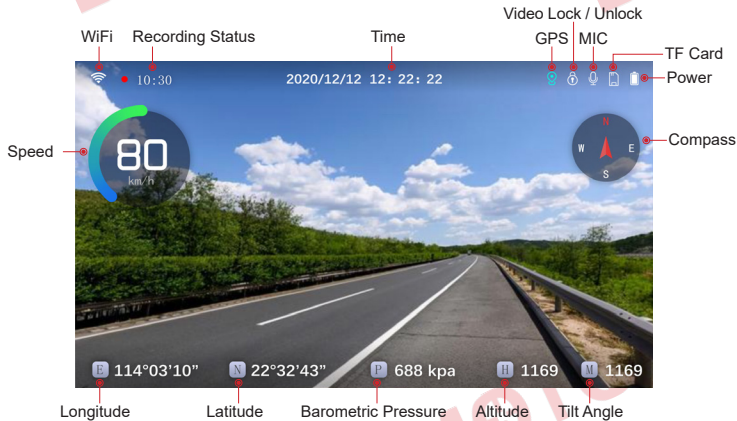

Recording Interface button function:

- Short press to enter the menu setting interface, long press to turn on/off the WiFi.
- Short press to switch the monitoring screen of the front and rear camera.
- Short press to enter the video management interface.
- Short press to enter the HUD interface, long press to turn on/off the dash-cam.

2.2 HUD Interface

- ▶ The HUD interface displays various values of the motorcycle, so that customers can understand the status of the motorcycle more clearly.
- ▶ In the recording interface, if there is no operation for 10 seconds (screen saver time can be set), the screen will automatically enter the HUD display interface.

HUD Interface Icon Introduction:

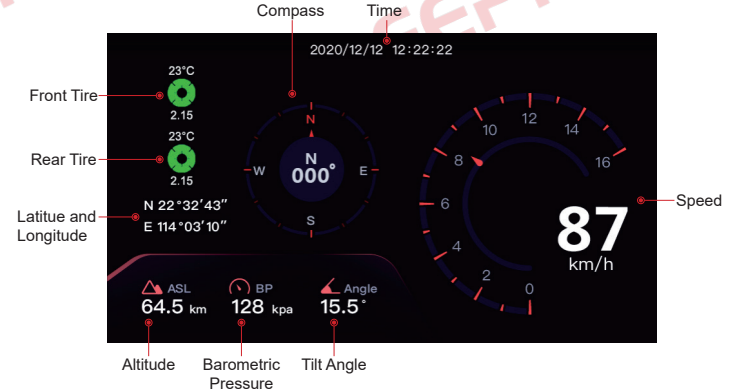

The green tire pressure icon means the connection is successful, and the gray means it is not connected. (Only D10Plus is equipped with tire pressure equipment)

Normal Tire Pressure	→	2.0 < Value < 3.0	→	White
Low Tire Pressure	→	Value < 2.0	→	Red
Too High Tire Pressure	→	Value > 3.0	→	Red
Tire Temperature Is Too High	→	Value > 65°	→	Tire Temperature Color Red

Special Note:

When the tire pressure position on the HUD interface does not display data for a long time, it may be that the battery of the tire pressure sensor is low, please replace the battery of the tire pressure sensor. Battery model: lithium battery CR1632.

2.3 Video Management Interface

- ▶ The video management interface can delete, lock and unlock the captured video.



Video Management Interface button function:

- Short press to play the video, long press to exit the interface to the recording interface.
- Short press to move up, long press to pop up a prompt box to delete video files.
- Short press to move down, long press to pop up a prompt box for locking/unlocking video files.
- Short press to switch the video recorded by the front camera/rear camera, and long press to switch on and off.

3. Menu Interface and Function Introduction

Recording Settings:



3.1 Parking Monitoring Sensitivity

The parking monitoring function is a function that after the motorcycle is turned off, the dash-cam senses that the motorcycle is hit, and automatically hides and starts recording for 15 seconds.

This function is off by default, and there are four options: high/middle/low/off.



3.2 Safe Driving

This function is turned on by default. When it is turned on, a prompt box will pop up after two hours of video recording: Please pay attention to fatigue driving.

3.3 Date Stamp

This option is enabled by default. After it is enabled, the time will be displayed in the lower right corner of the video when the dash-cam is recording. It is recommended to enable this feature.

3.4 Vibration Sensitivity

The D10Plus comes with a built-in vibration sensor that automatically detects any vibration that the motorcycle experiences. When the motorcycle is in motion, the vibration caused by the smoothness of the road can also trigger the vibration sensor. The vibration sensor monitors the intensity of the vibrations and automatically locks the recorded video, preventing it from being overwritten.

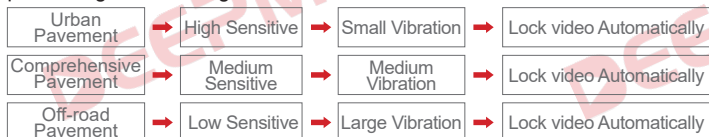

3.5 Loop Recording

After inserting the TF card, the dashcam will automatically start loop recording while the motorcycle is in the "on" state. The loop recording time can be set to 1 minute, 2 minutes, 3 minutes, or turned off. The default loop recording time is 1 minute.

3.6 WiFi

You can turn the WiFi function on or off in the settings. By default, it is turned off. When WiFi is turned on, the dash-cam will emit a wireless signal named "Deepmote_XXXXX". Users can connect to the WiFi signal on their mobile phones and manage video files through the mobile App.

3.7 Tilt Alarm

This feature monitors the tilt angle of the motorcycle's tires and will trigger an alert when the angle exceeds a certain value. By default, this feature is turned off.

- | | |
|---|--|
| • Scooter (Title Angle \geq 30°Alarm) | • Racing (Title Angle \geq 45°Alarm) |
| • Model (Title Angle \geq 40°Alarm) | • PRO (Title Angle \geq 50°Alarm) |

3.8 Mirror Preview

When this feature is turned on, the camera image will be mirrored. By default, this feature is turned off.

3.9 Screen Saver

Set the screen saver time: 10 seconds/30 seconds/1 minute/close, the default is 30 seconds. When the driving recorder is in the recording interface, without any operation, after 30 seconds, the screen will automatically enter the HUD interface.

3.10 Recording Audio

Set the microphone to be turned on or off, and it is turned on by default. When turned on, audio can be recorded during video recording.

System Settings:

Press the power button to switch to the system setting menu.

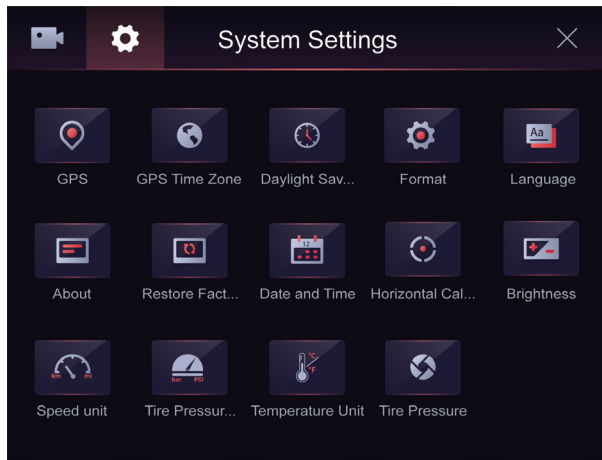

4.1 GPS

Set the GPS function to be on or off, and the default is on. Longitude, latitude, altitude and other information will be displayed only when the GPS is turned on. It is recommended to keep the GPS turned on.

4.2 GPS Time Zone

The default time zone is Beijing time in the East Eighth District, with a total of 24 time zones. Select the corresponding time zone according to different geographical locations. After selection, the GPS will display the corresponding time according to the selected time zone.

4.3 Daylight Saving Time

Daylight saving time, set to turn daylight saving time on or off.

4.4 Format

The TF card can be formatted, after formatting, the TF card will be cleared, please operate with caution.

4.5 Language

Set the language: Simplified Chinese/Traditional Chinese/English/Japanese/Korean.

4.6 About

Display the version information of the current machine software, WiFi name, WiFi password, and MAC number, which is the unique identification code of the machine.

4.7 Restore Factory Settings

Restore the settings of the dash-cam to the factory default settings.

4.8 Date and Time

To set the time of the device, short press the menu/OK key to enter the time adjustment, short press the up key or down key to adjust the time, after the adjustment is completed, short press the menu/OK key again to confirm. After the setting is completed, long press the menu/OK key to exit the time setting.

4.9 Horizontal Calibration

Calibrate the dash-cam horizontally. It is recommended to put the motorcycle in a straight position when calibrating.

4.10 Brightness

Set the brightness of the background light, the default background light brightness is high.

4.11 Speed unit

Speed unit, set the speed unit to "Kilometers" or "Miles".

4.12 Tire Pressure Unit

Set the tire pressure unit to "bar" or "PSI".

4.13 Temperature Unit

Set the temperature unit to "°C" or "°F".

4.14 Tire Pressure (Only D10Plus is equipped with tire pressure equipment)

Tire pressure needs to be matched before normal use. This function can pair the front wheel and rear wheel, and can also clear the paired front wheel/rear wheel device number.

DEEPMOTO
D10 Series

Tire Pressure Installation And Function Introduction

Only D10Plus is equipped with Tire Pressure Equipment.

1. Install the Tire Pressure Sensor

Open the Bag 11 tire pressure installation kit and take out the **Anti-theft Nuts**. Install the **Anti-theft Nuts** at the inflation ports of both the front and rear wheels. Install the Tire Pressure Sensors on the wheels of the front and rear wheels respectively. Use a **Nut Wrench** to tighten the anti-theft nuts counterclockwise.

Start the motorcycle and wait a few minutes for the tire pressure and temperature data to be displayed normally.

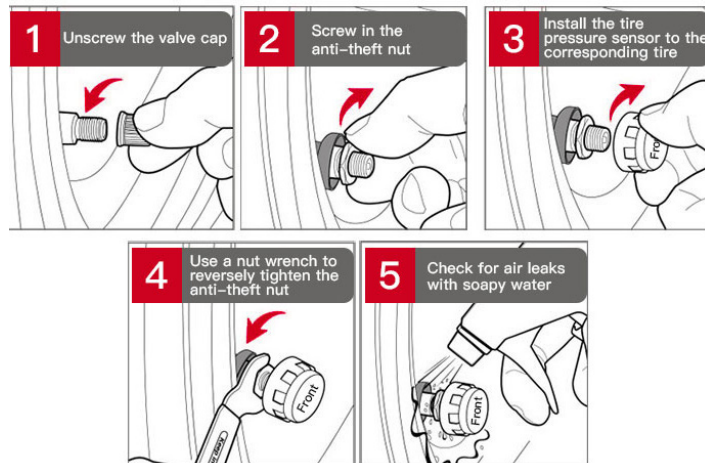

2. Tire Pressure Equipment Matching Function

Each host will match the tire pressure before leaving the factory. If user needs to re-pair, user needs to set it in the "Tire Pressure Device Matching" interface: press and hold the "Up Key"  and a prompt box will pop up, prompting "Whether to clear the tire pressure device matching ", click OK.

Quickly re-match Tire Pressure Method

open the cover on the tire pressure sensor and remove the button battery. Then, enter the "Tire Pressure Device Matching" interface on the host, wait for one minute, and insert the battery into the tire pressure sensor. The front/rear device number will appear, indicating that the pairing is successful.

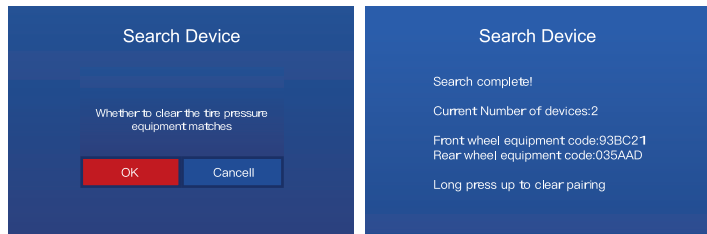

Tire Pressure Technical Parameter			
Part	Project	Parameter	
Tire Pressure Sensor	Working Frequency	433.9200MHz ± 0.1MHz	
	Operating Voltage	2.4 ~ +3.3V	
	Working Current	Static	≤ 1uA
		Working Current	≤ 15mA
	Working Temperature	-40°~+120°C	
	Monitoring Range Temperature	-40°~+130°C	
	Monitoring Range Air Pressure	0bar~3.5bar	
	Temperature Accuracy	±2°C	
Air Pressure Accuracy	±0.1bar		
Sensor Lithium Battery	Model	CR1632	
	Working Temperature	-30°C~80°C	

1. App Introduction

The video recorded by the dash-cam is saved in the TF card. Customers can use the App to download the video from the TF card to the mobile phone, which is convenient for editing and sharing the video.

Deepmoto's dash-cam has different models and functions, but there is only one corresponding app, that is, the app is universal for all models.

The app has a mainland China version and an international version. The app name of the mainland China version is "**Deepmoto**", and the app name of the international version is "**Philo Deepmoto**". No matter whether you download the mainland version or the international version, the functions of the app are the same.

2. App Installation Method

► **There are two ways to install the app in mainland China.**

(1) Search for "Deepmoto" in any application store of the mobile phone, find the application, download and install it.

(2) Download and install by scanning the QR code.



► **There are two ways to install the international version of the App.**

(1) Search for "Philo Deepmoto" in the Google Play application store, find the application, download and install it. It should be noted that the mobile phone must first install the Google Play application store.

(2) Download and install by scanning the QR code.



3. App WiFi Connection

After the dash-cam is turned on, search for the signal named "Deepmoto_XXXX_XX" in the WiFi signal of the mobile phone and connect it. Enter the password "12345678". After the connection is completed, return to the App interface, and the name of the connected WiFi will be displayed at the bottom of the interface. The WiFi signal of the example diagram is version D10A.

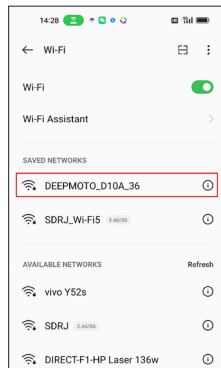

! Note:

When connecting to WiFi for the first time, a security prompt box will pop up, please click to "Decline", otherwise the connection will fail and the App will not be available. If the connection fails due to wrong click, please try to restart the dash-cam and restart the WiFi.

The Wi-Fi network "DEEPMOTO_D10A_36" is not connected to the Internet. Allow Wi-Fi Assistant to switch you to a better Wi-Fi network?

Decline

Allow

The "+" sign in the upper right corner of the App interface is also used to connect to WiFi. It will list the product model of Deepmoto. Click the button below the product model interface, the page will jump to the WiFi signal page of mobile phone. It might to wait 3 to 5 seconds because the slow system responding. It is recommended to connect directly on the mobile phone WiFi signal page.

4. App Function Introduction



4.1 Album

Click the album in the lower left corner to view the videos and pictures downloaded from the TF card, and click edit in the upper right corner to edit and share the videos and pictures.

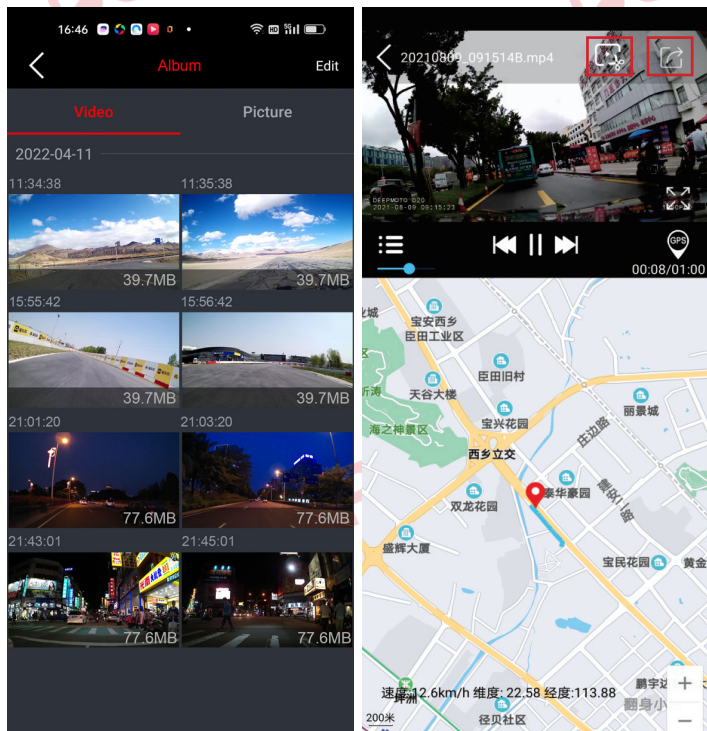
Click on the GPS to see the map and driving track. The Chinese interface uses Baidu Maps, and the English interface uses Google Maps. Please pay attention to the usage environment.



4.2 Video Monitoring

- ▶ Click the WiFi name to enter the real-time video monitoring interface. The flashing red light in the upper left corner of the video indicates that the camera is recording.
- ▶ Click the camera button  to switch the recording screen of the front camera/rear camera.
- ▶ Click the recording button  in the middle to stop/start recording.
- ▶ Click the video file list button  to view the pictures and videos saved in the TF card.
- ▶ Click "Disconnect" in the upper left corner to log out of the link.

4.3 Video Download

Enter the video file list to view the pictures saved in the TF card, loop videos and emergency videos (Locked Videos), click "Select" in the upper right corner to choose the desired videos and pictures to download or delete.

Video Monitoring:

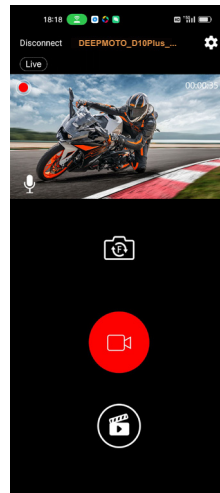

Video Download:

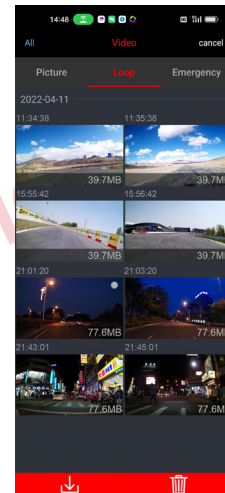

4.4 Setting

In the video monitoring interface, click the setting  in the upper right corner to enter the setting interface. WiFi password can be modified in this interface. Other functions are relatively simple and will not be described again.

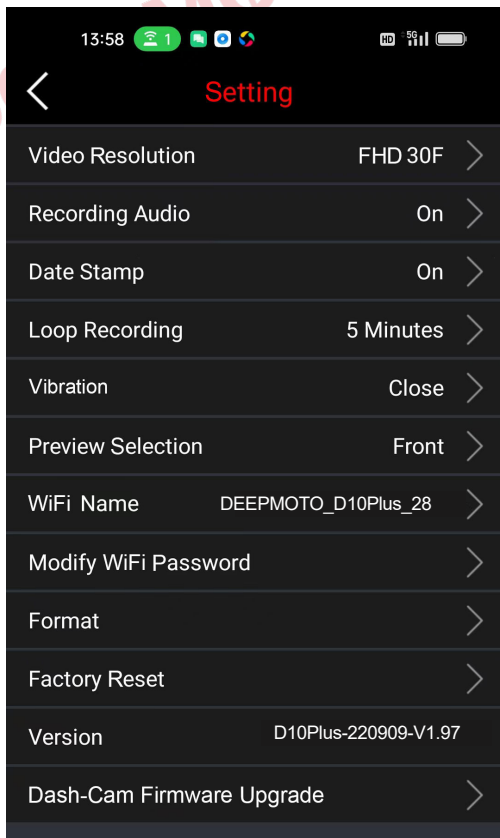

5. System Upgrade

There are two types of system upgrades, one is dash-cam host firmware upgrade, and the other is App software upgrade.

Host Firmware Upgrade

It is mainly to upgrade the software system and operation of the dash-cam host. Click "Host Firmware Upgrade" under the setting interface, and the host will enter the firmware upgrade state. During the upgrade process, the power cannot be cut off. Power failure may cause the host program to crash and cannot be turned on.

App Software Upgrade

It is mainly to upgrade the App application software interface and functions. To upgrade the App software, customers need to update or reinstall the App in the App Store.

Precautions:

- ▶ Before the firmware upgrade, it is recommended to format the TF card once, and after the upgrade is completed, format it again.
- ▶ For App software, it will not affect the use if it is not upgraded.

▶ Dash-cam Host-related Issues

? After the motorcycle is started, the dash-cam does not turn on / the dash-cam always displays the logo and cannot be turned on normally.

- Check whether the line connection is normal, and rule out whether the ACC contact is loose.
- If there is no problem with the ACC contact, check whether the position of the power cord connector is tightly inserted.
- Pull out the power cable and check whether there is water in the connector.
- If there is no problem, it may be that the power cord is abnormal and needs to be replaced.

? Abnormal phenomena such as crash occurred in the dash-cam.

Long press the power button to shut down and restart the dash-cam.

? TF card does not recognize.

Insert another TF card and try it. If there is no problem with the TF card, it is the problem of the host, and the host needs to be replaced.

? No GPS signal detected.

Check whether the GPS connection is normal, and there should be no interference around the GPS. Drive the motorcycle outside and check again.

? The HUD interface shows that other GPS information is normal, but the speed is 0.

Try to update the software, download the latest APP version, and upgrade the host firmware.

▶ Camera and Video Related Issues

? Video has no sound.

Check if the microphone is off.

? The dash-cam does not record after turning on.

- Check whether the TF card is inserted.
- Check whether the recorded videos are locked. After the capacity of the TF card is used up, the loop recording cannot be performed.
- Format the TF card, or try a new TF card.

? The dash-cam video monitoring interface displays a black screen.

Check whether the camera connection is normal, re-plug the camera, if the problem still exists, replace a new camera.

? Video is blurry.

Check the camera for dust, please wipe the camera.

? The video is locked during normal driving / the recorded video is all in the emergency video.

Adjust the vibration sensing sensitivity, or turn off the vibration sensing function.

? There will be stripe electromagnetic interference or purple stripe electromagnetic interference in the video displayed and recorded by the host.

- Check whether there is any problem with the camera wiring.
- When wiring, please run it smoothly, do not fold it and keep a certain margin.
- When tying the wiring, please do not tie it too tightly or squeeze it too tightly with the car shell.

▶ Application and WiFi Related Issues

? The WiFi connection is not working properly.

Check whether the WiFi is turned on, and the status bar of the screen will display  after it is turned on.

? App crashes.

Check the APP version number, download the latest App, and upgrade the dash-cam firmware.

Model	D10 Series
Dash-cam Material	Metal material
Dash-cam Voltage	5V/3A, Power box step-down line input 12V-36V range
Dash-cam Size	105mm X 72mm X 55mm
Dash-cam Weight	250g
Package Weight (including accessories)	1.05kg
Storage	C10 and above high-speed card 64G (can record for 6 hours) / 128G (can record for 12 hours) / 256G (can record for 24 hours)
Screen Size	3-inch IPS high-definition LCD screen, 854*480 pixels
Camera	6G+IR filter, F1.6 large aperture
Image Sensor	Sony IMX307
Air Pressure Sensor	ST Semiconductor
Shock Sensor	ST Semiconductor
Imaging Technology	Built-in video wide dynamic WDR technology, can backlight high-definition display image peripheral
Video Resolution	Video Resolution 1920*1080 pixels / 1080P / 30F
Video Format	TS format
GPS Function	External GPS, support track playback, with air pressure and altitude
WiFi signal	2.4G WiFi
Sound Input	External Microphone
Waterproof Level	IP67

DEEPMOTO



Shenzhen Shendu Software Co., Ltd.

🌐 www.deepdesign.com.cn ✉ Deepmotoservice@163.com

📍 308, Building A, Wenle Industrial Zone, Longzhu Community,
Xixiang Street, Bao an District,
Shenzhen City, Guangdong Province, China