

LIFOVE

HVLP PAINT SPRAYER

MODEL: LF807

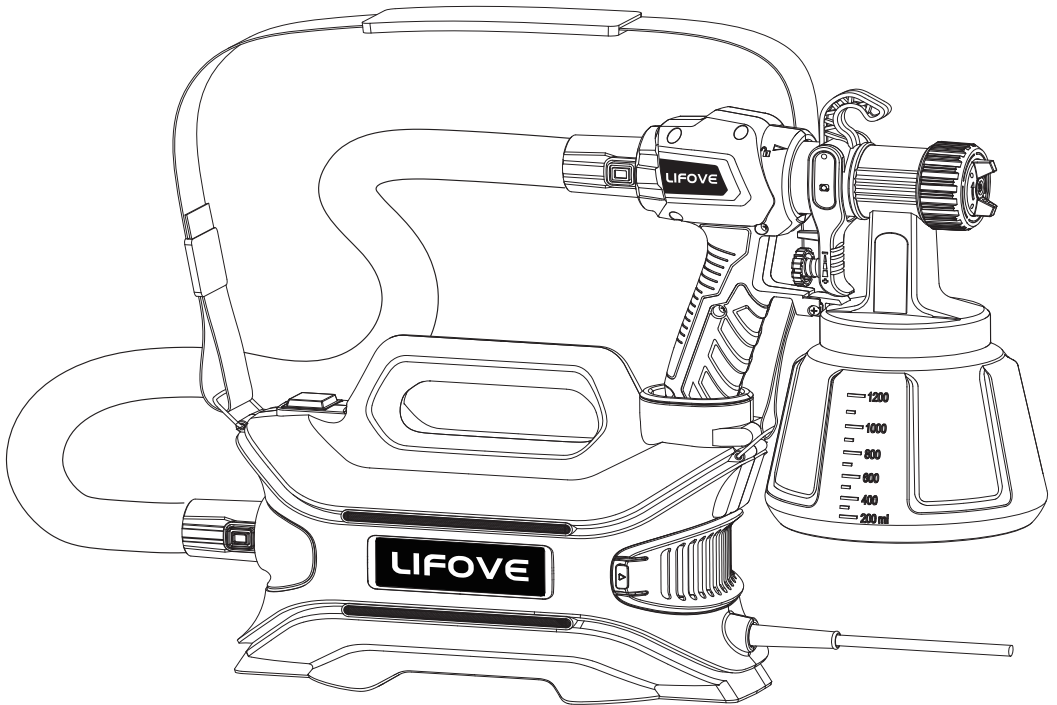

Please read the user manual carefully before operating!

Email: contact@lifovetools.com



THANK YOU FOR PLACING YOUR TRUST IN US.

We would like to congratulate you on your purchase of this product brand. We are confident that you will enjoy working with it very much.





Please read the Operating Manual carefully and observe the safety information before starting to use the device. Keep the Operating Manual in a safe place close to the product in case it needs to be used by someone else.

We would be happy to assist you with any questions, suggestions or requests you may have.

Contents

1. Explanation of symbols used	2
2. General Safety Instructions	3
3. Safety Instructions for Spray Guns	6
4. Description/ Scope of delivery	7
5. Field of application	8
6. Coating Materials Suitable for Use	9
7. Coating Materials Not Suitable for Use	9
8. The following materials can only be processed with optional accessories: . . .	10
9. Preparation of the workplace	10
10. Start-up	10
11. Preparation of the Coating Material	11
12. Selecting the Spray Setting (Fig. 6)	13
13. Adjusting the Material Volume (Fig. 8)	13
14. Spray Technique	14
15. Interruption of Work	15
16. Taking Out of Operation and Cleaning	15
17. Spare Parts	20
18. Maintenance	20
19. Accessories	20
20. Environmental protection.	21
21. Important Note regarding Product Liability!	22
22. Correction of Malfunctions	22
23. Technical Data	23
24. 12-Month Warranty	24

1. Explanation of symbols used

	This symbol is typically used to indicate a warning or caution and is often accompanied by specific instructions on how to avoid potential dangers or damage to the device. It's important to pay attention to these symbols and follow any instructions provided to ensure your safety and the proper functioning of the device.
	Danger of electrical shock
	Indicates tips for use and other particularly useful information.
	Devices and accessories marked with this symbol are suitable for processing high-viscosity materials such as e.g. interior wall paints (dispersions and latex paints). If a material bears this logo, it is particularly well suited for use with the relevant device.

2. General Safety Instructions

WARNING! Read all safety warnings and all instructions. *Failure to follow the warnings and instructions may result in electric shock, fire and/or serious injury.*



Save all warnings and instructions for future reference.



The term "power tool" in the warnings refer to your mains-operated (corded) power tool or battery-operated (cordless) power tool.

1. Work area safety

- a) **Keep work area clean and well lit.** Cluttered or dark areas invite accidents.
- b) **Do not operate power tools in explosive atmospheres, such as in the presence of flammable liquids, gases or dust.** Power tools create sparks which may ignite the dust or fumes.
- c) **Keep children and bystanders away while operating a power tool.** Distractions can cause you to lose control.

2. Electrical Safety

a) Users should only use power tool plugs that match the outlet they are intending to use. The plug should not be modified in any way as it could lead to electrical hazards. It is also advised not to use any adapter plugs with earthed (grounded) power tools. Using unmodified plugs and matching outlets will help reduce the risk of electric shock. It is important to follow these instructions to ensure safe operation of power tools and to prevent electrical accidents.

b) Avoid body contact with earthed or grounded surfaces, such as pipes, radiators, ranges and refrigerators. There is an increased risk of electric shock if your body is earthed or grounded.

c) Do not expose power tools to rain or wet conditions. Water entering a power tool will increase the risk of electric shock.

d) Do not abuse the cord. Never use the cord for carrying, pulling or unplugging the power tool. Keep cord away from heat, oil, sharp edges or moving parts. Damaged or entangled cords increase the risk of electric shock.

e) When you use a power tool outside, make sure you choose an extension cord that can be used outdoors. This will help to lower the possibility of an electric shock.

f) If you have to use a power tool in a damp area, be sure to use a power source that has residual current device (RCD) protection. This will help to lower the possibility of an electric shock.

3. Personal safety

a) When you use a power tool, you must pay attention to the operation and use common sense. Do not use power tools when you are tired or under the influence of drugs, alcohol, or medication, as a moment of carelessness can cause serious personal injury.

b) You should use personal protective equipment when using a power tool. Always wear eye protection. Using protective equipment such as a dust mask, non-slip safety shoes, hard hat, or ear protection in the appropriate environment can reduce personal injuries.

c) To avoid unintentional start-up, make sure the switch is in the off position before connecting to the power source and/or battery pack, or picking up or carrying the tool. Carrying power tools with your finger on the switch or starting a power tool with the switch on can lead to accidents.

d) Always remove any adjusting key or wrench before turning the power tool on. A wrench or key left attached to a rotating part of the power tool can cause personal injury.

e) Do not reach too far. Always keep your footing and balance. This will enable better control of the power tool in unexpected situations.

f) Dress properly. Do not wear loose clothing or jewelry, and keep your hair, clothing, and gloves away from moving parts. Loose clothes, jewelry, or long hair can get caught in moving parts.

g) Do not lull yourself into a false sense of security and do not think yourself above the safety rules for electric tools, even if you are familiar with the electric tool following extensive practical experience. Careless use can lead to serious injuries in fractions of a second.

4. Power tool use and care

a) Do not force the power tool. Use correct power tool for your application. The correct power tool will do the job better and safer at the rate for which it was designed.

b) Do not use the power tool if the switch does not turn it on and off. Any power tool that cannot be controlled with the switch is dangerous and must be repaired.

c) Disconnect the plug from the power source and/or the battery pack from the power tool before making any adjustments, changing accessories, or storing power tools. Such preventive safety measures reduce the risk of starting the power tool accidentally.

d) Store idle power tools out of reach of children and do not allow persons unfamiliar with the power tool or these instructions to operate the power tool. Power tools are dangerous in the hands of untrained users.

e) Maintain power tools. Check for misalignment or binding of moving parts, breakage of parts and any other condition that may affect the power tool's operation. If damaged, have the power tool repaired before use. Many accidents are caused by poorly maintained power tools.

f) Use the power tool, accessories and tool bits etc. in accordance with these instructions, taking into account the working conditions and the work to be performed. Use of the power tool for operations different from those intended could result in a hazardous situation.

g) Keep the handles and grip surfaces dry, clean and free of oil and grease. Slippery handles and grip surfaces hamper safe operation and control of the electric tool in unforeseen situations.

5. Service

a) Have your power tool serviced by a qualified repair person using only identical replacement parts. This will ensure that the safety of the power tool is maintained.

b) If the supply cord is damaged, it must be replaced by the manufacturer or its service agent or a similarly qualified person in order to avoid a safety hazard.

3. Safety Instructions for Spray Guns

• **Caution:** Paint mist and solvent vapors can be harmful to your health. Always wear breathing equipment and work only in well-ventilated rooms or use supplementary ventilating equipment. It is advisable to also wear protective clothing, safety glasses, ear protection, and gloves.



CAUTION: DANGER OF INJURY!

Never point the spray stream towards human beings or animals.



Sockets and plugs must be covered to prevent the risk of electric shock from sprayed material entering the socket.



Attention: Do not operate the device if the nozzle seal is damaged or missing. If the nozzle seal is damaged or missing, liquids can enter the device and increase the risk of electric shock. Check the nozzle seal before each use and tighten the union nut.

- Do not use the spray gun to spray flammable substances.
- The spray guns are not to be cleaned with flammable sol ents.
- Be cautious of the dangers that can arise from the sprayed substance, and follow the instructions and information on the containers or provided by the substance manufacturer.
- Do not spray any liquid of unknown potential hazards.
- The device may not be used in workplaces covered by explosion-protection regulations.
- To avoid the risk of explosion when spraying, ensure effective natural or artificial ventilation.
- There should be no sources of ignition, such as open fires, smoking cigarettes, cigars, or tobacco pipes, sparks, glowing wires, hot surfaces, etc., in the vicinity during spraying.

- Make sure that no solvent vapors are drawn into the unit. Do not spray onto the unit!
- The spray gun is not a toy, so children must not be allowed to handle or play with it.
- Before working on the spray gun, always unplug it from the power source. To prevent damage, cover any areas that should not be sprayed
- It's important to keep in mind that paint mist can travel long distances in the wind, so take care to work in a well-ventilated area and to avoid causing harm.
- The units may only be used with a functional valve. **If paints rises in the ventilating hose (Fig. 1, item 17 ) do not operate the unit further!** Dismantle and clean the ventilating hose, valve and diaphragm and replace the diaphragm if necessary.
- **Do not lay the spray gun.**

With original accessories and spare parts, you have the guarantee that all safety regulations are fulfilled.

4. Description/ Scope of delivery

Description/ Scope of delivery (Fig. 1)	
1. Carrying belt	2. Air hose
3. ON/OFF switch	4. Host
5. Material volume adjustment	6. Trigger
7. Handle	8. Spray gun front part
9. Union nut	10. Air Cap
11. 2.0mm nozzle	12. Container
13. Dust cover	14. Power Cord
15. 1.0mm nozzle	16. 1.5mm nozzle
17. 3.0mm nozzle	18. Cleaning joint
19. Dust blowing joint	20. Cleaning needle
21. Viscosity cup	22. Cleaning brush
23. Paint filter	

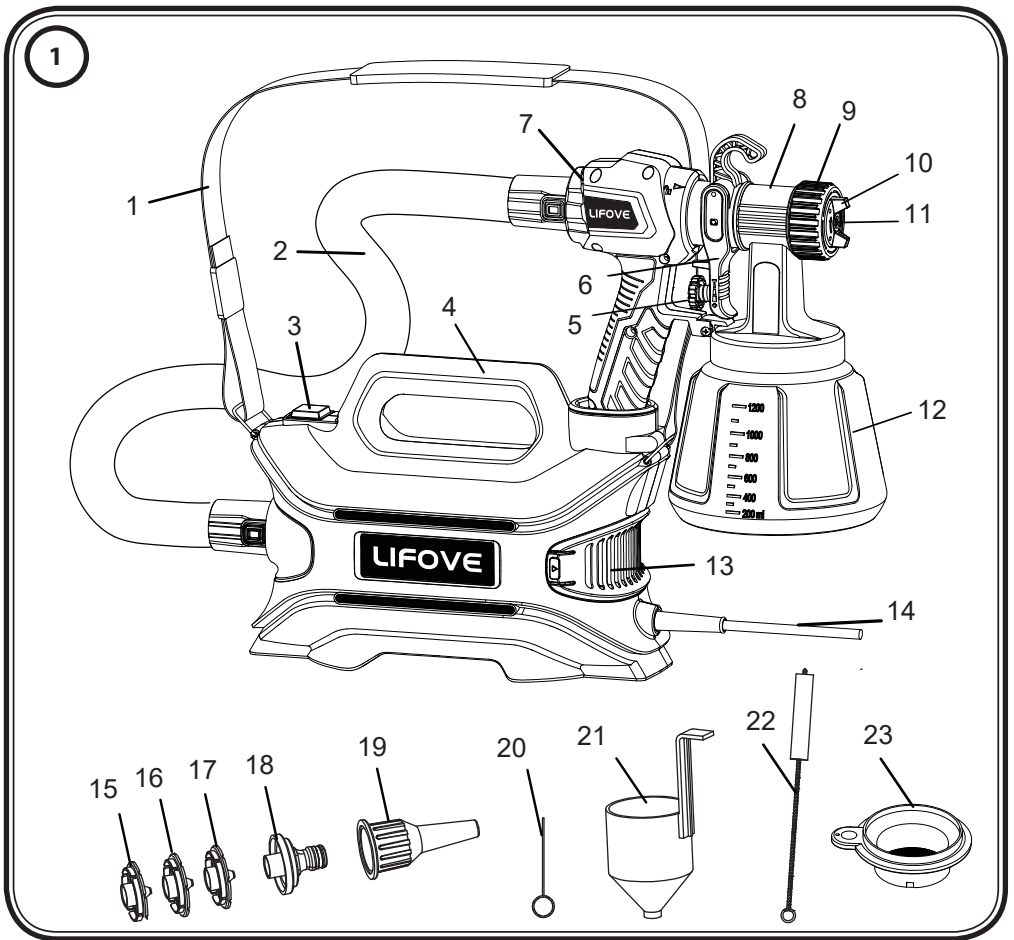

5. Field of application

This product is suitable for use with water- and solvent-based paints, finishes, primers, 2-component paints, clear finishes, automotive finishes, staining sealers, and wood sealer-preservatives. It is also compatible with all coating materials that bear the red Perfect Spray logo

6. Coating Materials Suitable for Use

Interior wall paint (dispersions and latex paint)

7. Coating Materials Not Suitable for Use

Materials that contain highly abrasive components, facade paint, caustic solutions and acidic coating substances. Flammable materials.

8. The following materials can only be processed with optional accessories:

Water- and solvent-based paints, finishes, primers, 2-component paints, clear finishes, automotive finishes, staining sealers and wood sealer-preserved.

9. Preparation of the workplace



Sockets and plugs must be masked. Risk of an electric shock as a consequence of sprayed material entering the socket!



Mask all the areas and objects that are not to be spray painted, or remove them from the work area. No liability is assumed for damage due to overspray.

Silicate paint corrodes glass and ceramic surfaces upon contact! All such surfaces must therefore be completely covered.



When using adhesive tape, pay attention to the quality of the tape to ensure good adhesion without damaging the surfaces.

Avoid using excessively strong adhesive tape on wallpaper and painted surfaces to prevent damage during removal. When removing the tape, do so slowly and evenly, avoiding jerky movements.

Do not leave the tape on the surfaces any longer than necessary to minimize the risk of leaving residues when removing it.

Be sure to follow the adhesive tape manufacturer's instructions to ensure proper use and best results.

10. Preparation of the Coating Material



For better spray results, use spray material at room temperature or diluted with warm water. Do not heat spray material above 40°C.

Interior wall paints can be sprayed undiluted or slightly diluted with the spray attachment provided.

1. Thoroughly stir the material and dilute it in the container according to the recommended dilution, using an agitator if available

Thinning recommendation	
Sprayed material	
Interior wall paint (dispersions and latex paint)	dilute by 0-10 %

2. If the feed rate is too low even at the maximum flow setting, dilute the material in increments of 5-10% until the feed rate meets your requirements (while adhering to the maximum allowable dilution specified by the manufacturer).

11. Start-up

Before connecting to the mains supply, be sure that the supply voltage is identical with the value given on the rating plate.

- Attach the carrying strap to the unit. (Fig. 2)
- Unscrew the container from the spray gun.
- Align the suction tube (Fig. 3)

If the suction tube is positioned correctly, the container contents can be sprayed without almost any residue. When spraying horizontal surfaces, turn suction tube forward. (Fig. 3 A) When spraying objects overhead, turn suction tube back. (Fig. 3 B)

- Place the container on a paper base and pour in the prepared coating substance with using the included feed hopper included in the scope of supply (Fig. 1, 21) Screw the container tightly onto the spray gun.

- Attach the front part to the rear part of the gun. (Fig. 5)

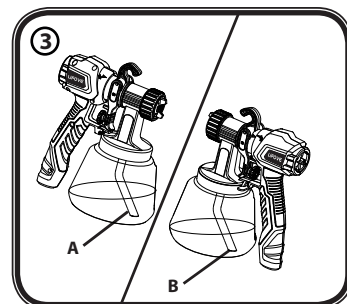
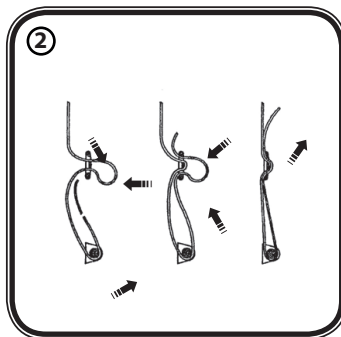

● **Before use**

Checking viscosity

- The product allows you to use spray material with a viscosity of maximum. 120DIN/sec.

Measure viscosity

- Fill the measuring cup [right figure] with spray material
- Let the liquid flow out of the measuring cup [right figure].
- Measure the seconds until the spray material
- Put the paint filter on the container, and filter the measured spray liquid into it through the paint filter.

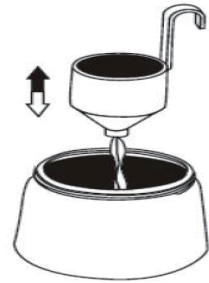

1

Notice:

Stop flowing out of the measuring cup [right figure 1]. The measured result is the DIN/sec value Dilute the spray material gradually with a suitable diluent until you measure a value ≤ 120 DIN/sec. Only use thinners that are suitable for the respective spray material. Using the wrong thinner can cause lumps to form and clog the product.



2

Never mix synthetic resin paints with nitro thinner! Read the manufacturer's instructions for the respective spray material to find out about the appropriate thinners. Do not spray materials containing granules or solid particles.

The table below shows recommended run-DIN-seconds for different types of material

Solvent-based paints	15-50
Primers	25-50
Pickling	no need to dilute
Component paints	20-50
Varnishes	15-40
Waterborne paints	20-40
Automotive topcoats	20-40
Wood preservatives	no need to dilute
Clear Sealer, Polyurethane, Stain	no need to dilute
Enamel, Latex Paint	25-40

If the paint takes longer than the recommended time to empty, then further thinning is required. Mix a small quantity of the appropriate thinner into the paint and use the viscosity test until the desired viscosity is reached.

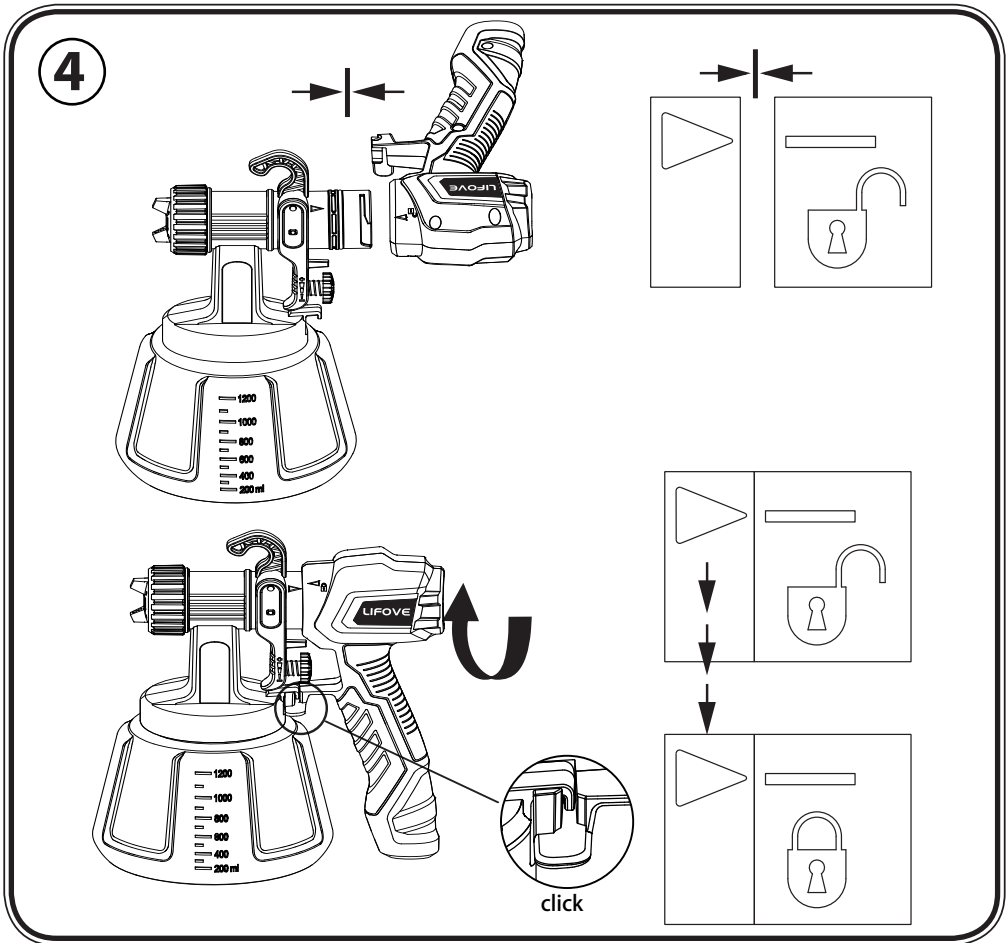

Attach the air hose (Fig. 5 a+b) by firmly inserting it into the connection of the unit and the gun handle.

The orientation of the hose does not matter.

Place the machine only on a level and clean surface. Otherwise, the gun may suck in dust or debris.

Put on the carrying strap and sling it over your shoulder.

Press the ON/OFF switch on the device to turn it on.

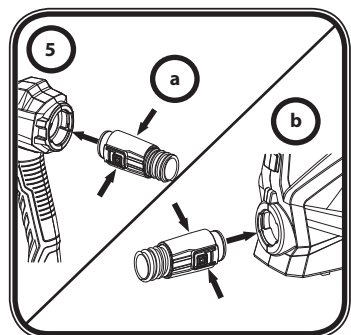

12. Selecting the Spray Setting (Fig. 6)



WARNING! Danger of injury! Never pull the trigger guard while adjusting the air cap.

3 different spray jet shapes can be set by turning the air cap (**fig. 6, 1**)



Tighten the union nut (**Fig. 6, 2**) fully so that no paint is able to penetrate the device. Check regularly whether the union nut has worked loose during operation.

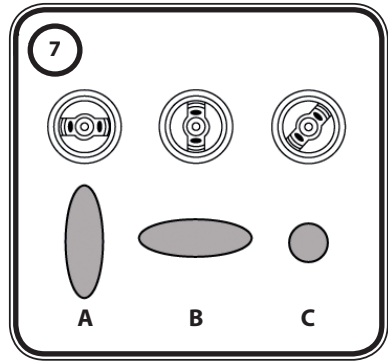
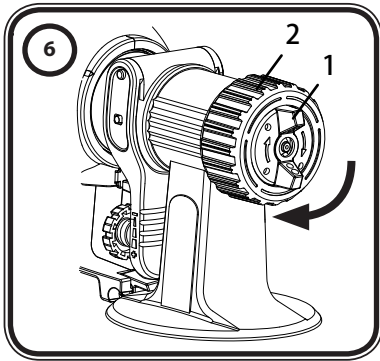

Fig. 7A: Vertical flat jet - for spraying on horizontal surfaces.

Fig. 7B: Horizontal flat jet - for spraying on vertical surfaces.

Fig. 7C: Circular jet - for spraying on corners, edges, and hard-to-reach surfaces.

To change the spray jet shape and width, replace the air cap (1) with the desired one.

13. Adjusting the Material Volume (Fig. 8)

"To adjust the material volume, turn the regulator on the trigger guard of the spray gun:

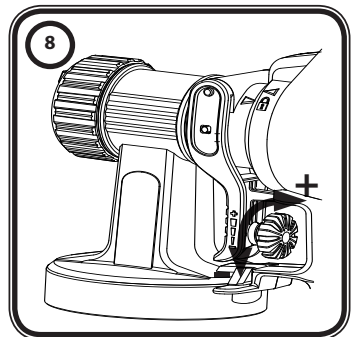

Turn left to decrease the material volume.

Turn right to increase the material volume.



For most wall paints, the best results are achieved with an average flow setting.

14. Spray Technique

- Cover all surfaces that will not be sprayed.
- It is advisable to test the spray gun on cardboard or a similar surface to find the correct settings.

Important: Start spraying from the edge of the area to be sprayed. Begin the spray movement first, and then press the trigger. Avoid stopping or interrupting the spray within the area being sprayed.

The spray movement should come from the arm, not just from the wrist. This ensures that a uniform distance is maintained between the spray gun and the spray surface during the spray operation. Select a distance of 20-30 cm, depending on the desired spray jet width.

Fig.9 a: CORRECT - Maintain an even distance between the spray gun and the object.

Fig.9 b: INCORRECT - Uneven distance will result in uneven paint application.

- Move the spray gun evenly in a cross-wise or up-and-down motion, depending on the spray pattern setting.
- Even movement of the spray gun results in a uniform surface quality.
- If the nozzle and air cap are soiled, clean both parts with water and solvent.



Use a 'cross spray' technique when using paint with poor covering capacity or if the surface is highly absorbent



(Fig.10). Interior wall paints in strong color shades should be applied at least twice, allowing the first paint coat to dry first. This will ensure good coverage.

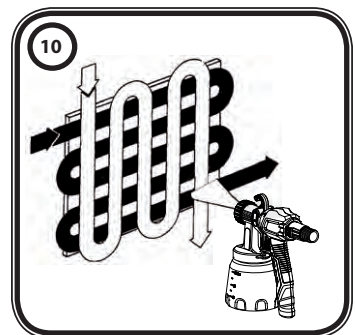
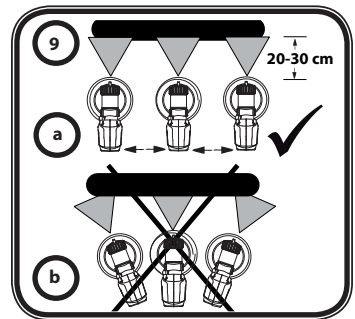

15. Interruption of Work

- Turn the machine off.
- During longer breaks, vent the container by briefly opening and then closing it again.
- Clean nozzle openings after an interruption in operation.

16. Taking Out of Operation and Cleaning

- 1) Turn off the machine.
- 2) Detach the spray gun by pressing the hook (Fig. 4 "click") slightly downwards and turning the gun front part and rear part in opposite directions.
- 3) Unscrew the container and empty it. Remove the suction tube with container seal.
- 4) Pre-clean the container and feed tube with a brush. Clean the ventilation bore (Fig. 11, 1).

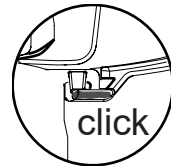

"We recommend using a common household washing-up brush to clean the container.

- 5) Pour water or solvent into the container and screw it back on. Do not use flammable materials for cleaning purposes.
- 6) Reassemble the gun (Fig. 4).
- 7) Turn on the machine and spray the water or solvent into a container or cloth.
- 8) Repeat the above procedure until the water or solvent emerging from the nozzle is clear.
- 9) Turn off the machine and detach the spray gun.
- 10) Unscrew the container and empty it. Remove the suction tube with container seal."

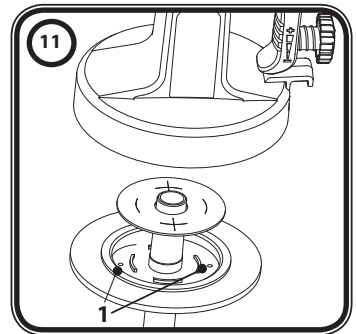

CAUTION! Never clean seals, diaphragm and nozzle or air holes of the spray gun with metal objects. The ventilation hose and diaphragm are only solvent-resistant to a limited extent. Do not immerse in solvent, only wipe.

11) The device can only be operated with an integer valve (**figs. 12,1**) . If paint passes through the valve clearance (**figs. 12,1**) , check and clean the valve (see Maintenance Section) .

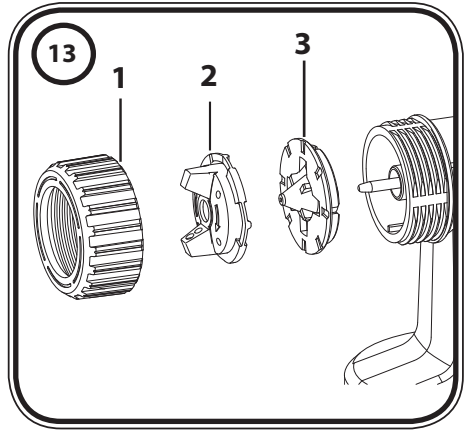
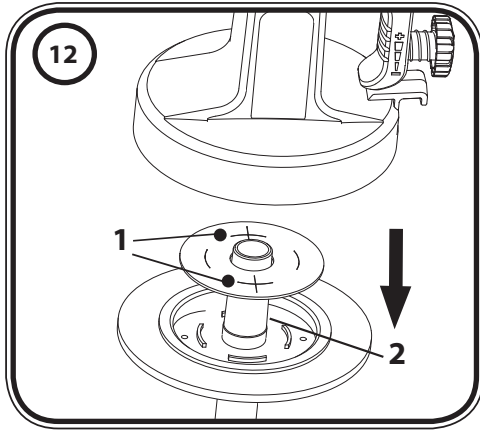

12) Rotate the mounting nut (**fig. 13,1**) to remove and remove it more easily.

13) Unscrew the mounting nut (13.1) . Clean the air cap (2) and the nozzle (3) with a hand brush solvent or water.

14) Clean the outside of the spray gun and container with a cloth soaked in solvent or water.

15) Assemble the parts again (see “Assembly”).

16) Another quick way to clean the inner passage: one end of the pipe is connected to the faucet and the other end is connected to the cleaning joint. Open the faucet and flush the inner channel of the gun body. As shown in (fig.16)

Assembly

1) Screw the union nut (Fig. 14, 1) onto the gun and tighten it.



Ensure that the union nut (Fig. 14, 1) is fully tightened to prevent paint from penetrating the device.

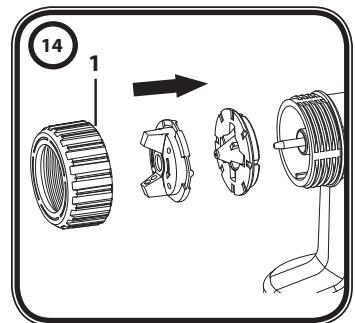

15

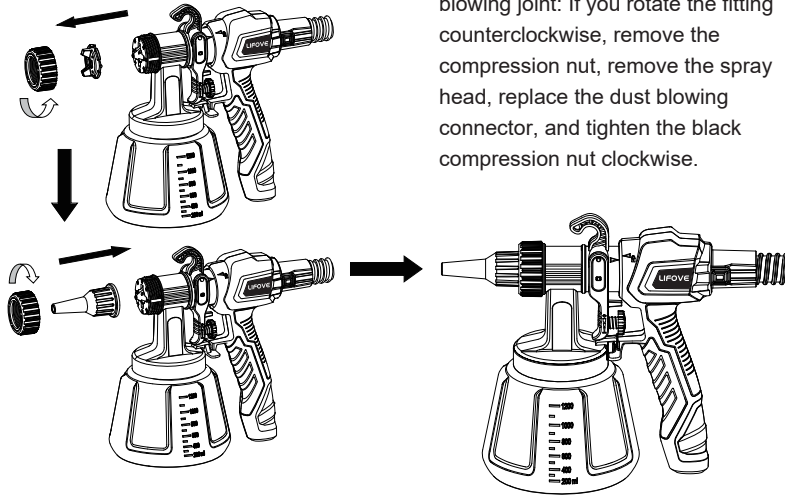

Replacement instructions for the dust blowing joint: If you rotate the fitting counterclockwise, remove the compression nut, remove the spray head, replace the dust blowing connector, and tighten the black compression nut clockwise.

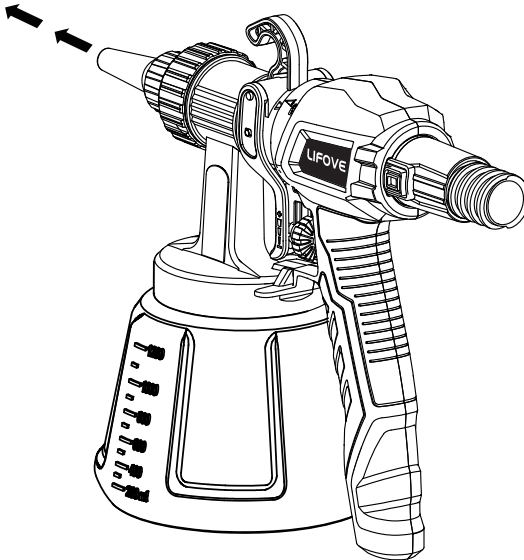

Instructions for dust blowing / inflation:

It is used to clean and narrow gaps (such as door and window seams, computer chassis, etc.), and can also be used for inflation, such as yoga ball, air cushion bed, children's toys, etc.

16

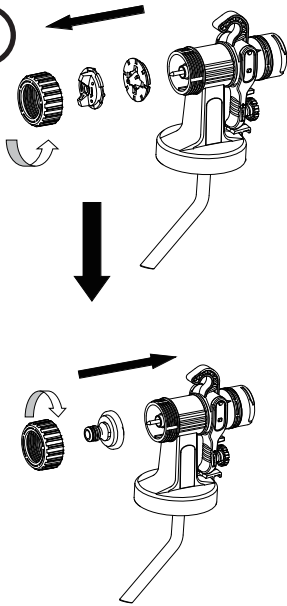

Cleaning joint replacement instructions: If the figure is counterclockwise, remove the pressing nut, remove the spray head and nozzle, replace the cleaning joint, and tighten the fastening nut clockwise.

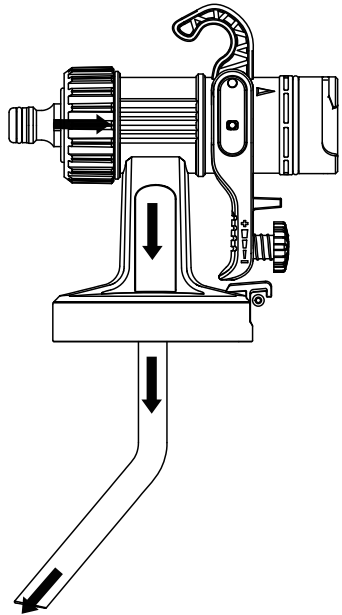

Cleaning instructions:

One end of the water pipe is connected to the tap, and the other end is connected to the cleaning joint. Turn on the tap to flush the internal channel of the gun body.

- 2) Place the container seal from below onto the suction tube and slide it over the collar while turning the container seal slightly for a secure fit."
- 3) Insert the sealed straw firmly into the gun body, ensuring that it is fully inserted. To make mounting the gun easier, apply the enclosed lubricating grease generously to the O-ring at the front part of the gun (see Figure 17, 5).

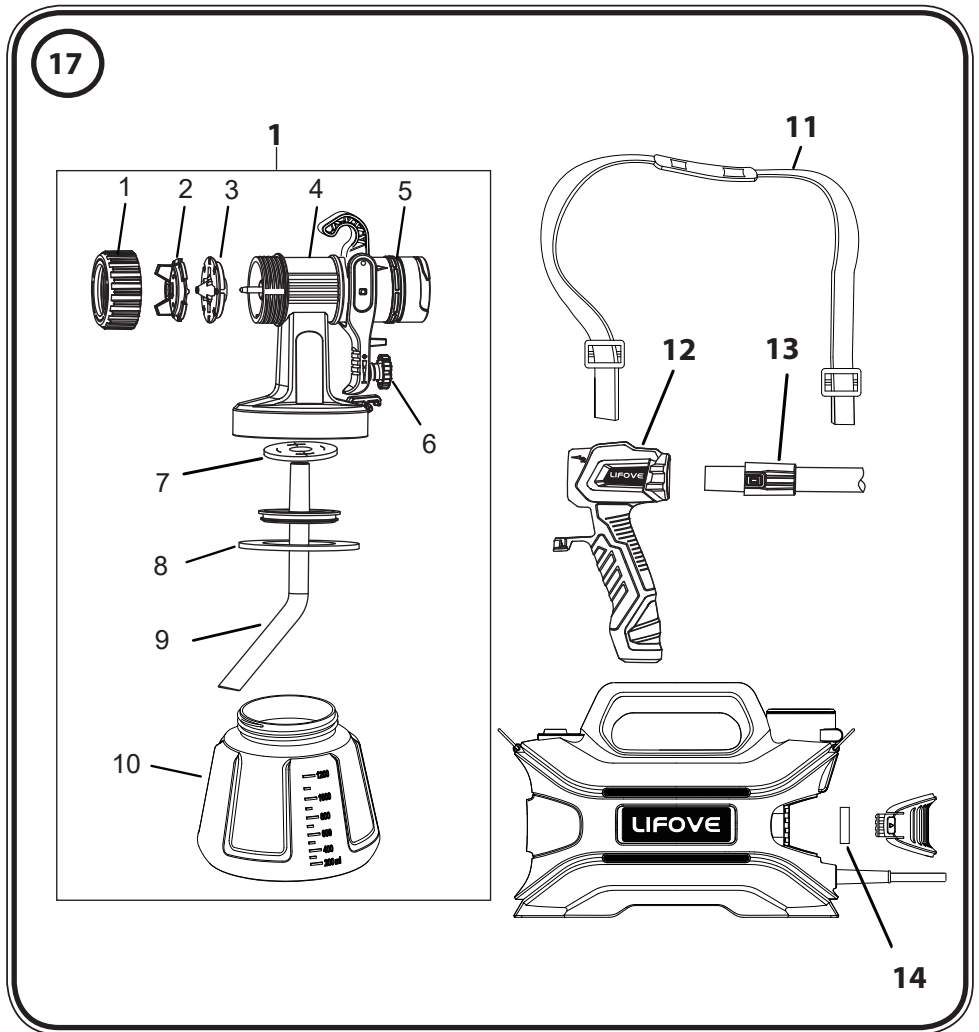

17. Spare Parts

Spare Parts List (Fig. 17)		
Pos.	Name	
1	Union nut	
2	Air Cap	
3	Nozzle	
4	Spray gun front part	
5	O-ring	
6	Material volume adjustment	
7	Valve	
8	Container seal	
9	Suction tube	
10	Container with cover	
11	Carrying belt	
12	Handle	
13	Hose	
14	Air filter	

18. Maintenance

WARNING: Never operate the machine without the air filter, as dirt could be sucked into the machine and interfere with its function. Always disconnect the plug before changing any parts.

To change the air filter, follow these steps:

- Pull the soiled air filter out of the unit (see Figure 18).
- Insert a new air filter into the compartment.

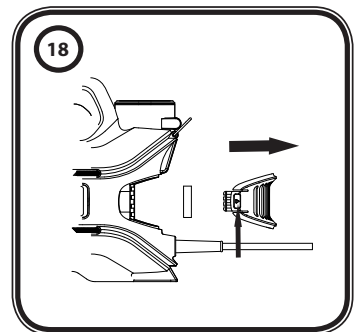

Ventilating Valve

1) Pull the straw out of the bottom of the gun (see Figure 12.2) and remove the valve (see Figure 12.1) from the straw. Clean the part carefully, or replace it if it is damaged.

2) Insert the valve (see Figure 12.1) into the upper portion of the straw and place it in the groove.

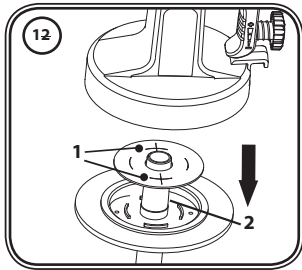

19. Accessories

The **CLICK&PAINT SYSTEM** with additional spray attachments and accessories offers the right tool for each work.

20. Environmental protection



To protect the environment, the device, accessories, and packaging should be recycled in an environmentally friendly manner. Do not dispose of the appliance with household waste. Support environmental protection by taking the appliance to a local collection point, or obtain information from a specialist retailer. Leftover paint and solvents must not be emptied into drains, the sewage system, or disposed of as household rubbish. They should be disposed of separately as special waste. Please pay special attention to the instructions on the product packaging for proper disposal.

21. Important Note regarding Product Liability!

According to an EU directive, the manufacturer is only liable without limitation for faults in the product if all parts come from the manufacturer or have been approved by the manufacturer and have been mounted to the device and are operated properly. If third-party accessories or spare parts are used, the manufacturer is exonerated wholly or partly from his/her liability if use of the third-party accessories or spare parts have caused a defect in the product.

22. Correction of Malfunctions

Problem	Cause	Remedy
No coating material emerges from the nozzle	<ul style="list-style-type: none"> • Nozzle clogged • Material quantity too small • No pressure build-up in container • Container empty • Feed tube loose • Feed tube clogged • Vents (figs. 11,1 and 12,1) clogged 	<ul style="list-style-type: none"> → Clean → Increase the quantity of material → Tighten container → Refil → Insert → Clean → Clean
Coating material drips from the nozzle	<ul style="list-style-type: none"> • Coating material assembly at air cap, nozzle or needle • Nozzle loose • Nozzle seal is missing or worn • Nozzle worn 	<ul style="list-style-type: none"> → Clean → Union nut tighten → Change → Change
Atomisation too coarse	<ul style="list-style-type: none"> • Material volume too large • Nozzle contaminated • Air cap assembled incorrectly • Viscosity of coating material too high • Too little pressure build-up in container • Air filter heavily soiled 	<ul style="list-style-type: none"> → Reduce the material volume → Clean → Tighten the fixing nut in place properly(Fig.14) → Dilute further → Tighten container → Change

Problem	Cause	Remedy
Spray jet pulsates	<ul style="list-style-type: none"> • Coating material in container running out • Nozzle seal is missing or worn • Air filter heavily soiled 	→ Refill → Replace → Change
Coating material causes "paint tears"	<ul style="list-style-type: none"> • Too much coating material • Paint viscosity is too low 	→ Reduce the material volume → Dilute less
Too much fog of coating material (Overspray)	<ul style="list-style-type: none"> • The distance from the object is too far • Too much coating material 	→ Reduce distance → Reduce the material volume
Paint in the ventilating hose	<ul style="list-style-type: none"> • Diaphragm soiled • Diaphragm defective 	→ Clean the diaphragm → Replace the diaphragm
Poor covering capacity on the wall	<ul style="list-style-type: none"> • Spray material is too cold • Highly absorbent surface or paint with poor covering capacity • The distance is too far 	→ Spraying materials should be stored in a normal room. → Cross spray(See Fig.10) → Closer to the object

23. Technical Data

Technical Data	
Model:	LF807
Max viscosity:	120din-s
Voltage:	120V 60Hz
Motor Power:	800W
Max Flow:	1500ml/min
Power Cord:	1.8m/6ft
Air Hose:	2m/6.5ft
Container Capacity:	1200ml/40 fl oz
Nozzle Size:	1.0,1.5,2.0,3.0mm
Class:	II
Weight:	2.5Kg

24.12-Month Warranty

12-MONTH LIMITED WARRANTY OF LIFOVE PRODUCTS FOR HOME USE

In operation and use, if you encounter problems that you cannot solve by yourself, please don't worry. For example:

1. If you receive the product, there are water droplets in it, this is normal, because we will test each product with water before packaging.
2. If there is some grease at the interface of the product, this is normal, in order to allow the product to be disassembled and assembled more flexibly.
3. If there is obvious paint in the new product you receive and it affects your use, this is not normal. It is most likely that the product returned by other Amazon customers. For this, please allow me to apologize to you and explain: We chose the "fulfilled by amazon" service, which means that once we ship the goods to the Amazon warehouse, we have no control over the inventory, for example, we can't decide Ship/Delivery time, ship method, customer's return and exchange, etc., all of which are completed by the Amazon warehouse.
- 4 If you need to purchase additional accessories but cannot find it, we will guide you on how to purchase them.
5. If the product effect is not good and does not work, please send us an email through your order number in time, our customer service team and technical team will provide professional guidance to solve the problem within 24 hours until you are satisfied. Thanks!

**For questions/feedback, technical assistance, or repair parts,
Please contact our after-sales E-mail: contact@lifovetools.com**

