

NORTHWOODS

MOUNTAIN BIKE ASSEMBLY

THIS INSTRUCTION BOOKLET CONTAINS IMPORTANT SAFETY
INFORMATION. PLEASE READ AND KEEP FOR FUTURE REFERENCE.

FOR SERVICE ASSISTANCE CALL TOLL FREE 1.800.451.5368

Monday - Friday 8:00 a.m. to 4:00 p.m. Eastern Standard Time

Congratulations on the purchase of your new bike! With proper assembly and maintenance it will offer you years of enjoyable riding!

IMPORTANT:

Carefully read and follow this manual (and any other materials included with this bike) before riding. Please retain this manual for future use. If this bike was purchased for a child, it is the responsibility of the purchaser to verify the bike has been properly assembled, and that the user has been properly trained and instructed in use of the bike.

This manual is provided to assist you and is not intended to be a comprehensive manual covering all aspects of maintaining and repairing your bicycle. The bicycle you have purchased is a complex piece of equipment that must be properly assembled and maintained in order to be ridden safely. **If you have any doubts about the assembly or your ability to properly assemble and maintain the bicycle. You must have it assembled and maintained by a professional bicycle mechanic.**

 **DANGER! Failure to properly assemble and maintain your bicycle could result in serious injury or death to the rider.**

Check and read this decal on your bicycle before each ride:

WARNING!
ALWAYS WEAR A HELMET
Make Sure Stem And Pedals Are Tight.
Check Your Brakes.
Do Not Ride At Night.
Read Owners Manual.
For A Free Owner's Manual Or Questions Call 1-800-451-5368
MADE IN CHINA

**ALWAYS WEAR A PROPERLY FITTED
HELMET WHEN YOU RIDE YOUR
BICYCLE. DO NOT RIDE AT NIGHT. AVOID
RIDING IN WET CONDITIONS.**

RESPONSIBILITY OF THE OWNER!

IMPORTANT: Reading and following the information and instructions in this manual are essential to your ability to ride safely.

1. It is the responsibility of the owner or in the case of a younger rider the parents of the rider to be certain all assembly instructions have been followed, even if the bike has been assembled by the seller or a professional assembly company.
2. Brakes are essential to safety. Be sure they are checked and working properly before each use. Remember that any mechanical system changes condition during use and must be maintained and checked before each use.
3. Rules for bicycle use (bicycle laws) vary from location to location so be certain the rider knows and understands the rules that apply to bicycle usage in your area. Wearing a helmet and using lights and reflectors are two examples of rules which may exist and which make sense as rider safety precautions at all times.
4. Know how to operate the bicycle and all equipment on it before first use and be certain anyone else allowed to use the bike knows how to properly and safely use the bike as well.
5. There are many different types of bicycles and often these types are designed for different uses. Make sure you know what type unit you have and do not exceed its service limitations. Be sure you check and understand the bicycle classifications set forth below, including size of the unit that is proper for the rider to insure good control during use. Riders who are too small may have control problems. Do not overload a unit with a rider that is too heavy or too large, and do not attempt to carry extra passengers, packages or loads on the bicycle. Do not attempt to use street bikes for off road riding.

Mountain Bikes. (Max weight of rider+luggage+bike = 275lbs/125kg). These bikes are intended for use off road on trails where tree-roots and rocks are likely to be encountered. The use of a bike in hazardous conditions such as on changeable and uneven surfaces can put very high unpredictable loads on the bike and it's components. Lack of rider skill and experience of these conditions can further increase these loads leading to the possibility of serious damage to the bike and injury to the rider. **Wear a helmet at all times. Check your bike frequently for loose or damaged parts and do required maintenance.**

Condition 1—This is a set of conditions for the operation of a bicycle on a regular paved surface or smooth unpaved surface where the tires may unintentionally lose ground contact.

OWNER'S RESPONSIBILITY *continued*

NOTE: Carefully read this manual and follow instructions. Your bicycle may come with additional instruction sheets that cover features unique to your bike. Please ensure that you read and become familiar with their contents. Proper assembly, use and maintenance of components like quick release hubs and brakes are essential to rider safety. Always wear a CPSC approved helmet when riding your bike. Familiarize yourself with local and state traffic and use laws. Keep all materials which come with the bike for future reference.

Any major service or adjustments on your bike should be carried out by a competent adult or professional bike mechanic. If you wish to make adjustments yourself, this manual contains important tips on how to do it. **CAUTION:** Any adjustments you make are entirely at your own risk. Do **NOT** use your bike for freestyle and stunt riding, jumping or competitive events. Even if you are riding a mountain bike, you should know that off-road use or any similar activities can be dangerous, and you are warned that you assume the risk for personal injury, damages or losses, incurred from such use. Do not ride your bike when any part is damaged or not working properly. If you are unsure how to carry out repairs or maintenance on your bike, it is vital that you promptly consult a local bike mechanic for professional assistance and support.

WARNING: AS WITH ALL MECHANICAL COMPONENTS, THE BICYCLE IS SUBJECTED TO WEAR AND HIGH STRESSES. DIFFERENT MATERIALS AND COMPONENTS MAY REACT TO WEAR OR STRESS FATIGUE IN DIFFERENT WAYS. IF THE DESIGN LIFE OF A COMPONENT HAS BEEN EXCEEDED, IT MAY SUDDENLY FAIL, POSSIBLY CAUSING INJURIES TO THE RIDER. ANY FORM OF CRACK, SCRATCHES OR CHANGE OF COLORING IN HIGHLY STRESSED AREAS INDICATE THAT THE LIFE OF THE COMPONENT HAS BEEN REACHED AND SHOULD BE REPLACED.

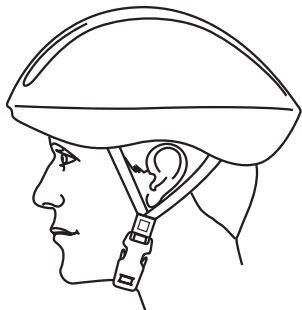

Correct
Forehead covered

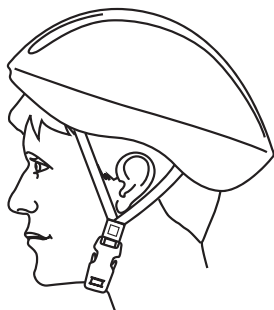

Incorrect
Forehead exposed



ALWAYS WEAR A HELMET- IT COULD SAVE YOUR LIFE!

A properly fitting, CPSC approved, bicycle helmet should be worn at all times when riding your bicycle. In addition, if you are carrying a passenger (only use an approved child safety seat), and remember, the passenger must also be wearing a helmet

The correct helmet should:

- be comfortable
- be lightweight
- have good ventilation
- fit correctly
- cover the forehead
- be securely fastened on the rider.

TABLE OF CONTENT

Parts Identification Graphics.....	5
Before Riding.....	6-11
Assembly Instructions.....	12-35
Maintenance.....	36-53
Warranty.....	54

WARNING / CAUTION

Throughout this manual you will see the words **WARNING** and **CAUTION**.

Please pay special attention to this information, as it could affect your safety as you assemble and ride your bike.

**ALWAYS WEAR A PROPERLY FITTED
HELMET WHEN YOU RIDE YOUR
BICYCLE. DO NOT RIDE AT NIGHT.
AVOID RIDING IN WET CONDITIONS.**

MOUNTAIN BIKE PARTS IDENTIFICATION

NOTE: This is a typical bicycle. Your bike may have other or different parts, and in some cases, may not have all parts shown here.

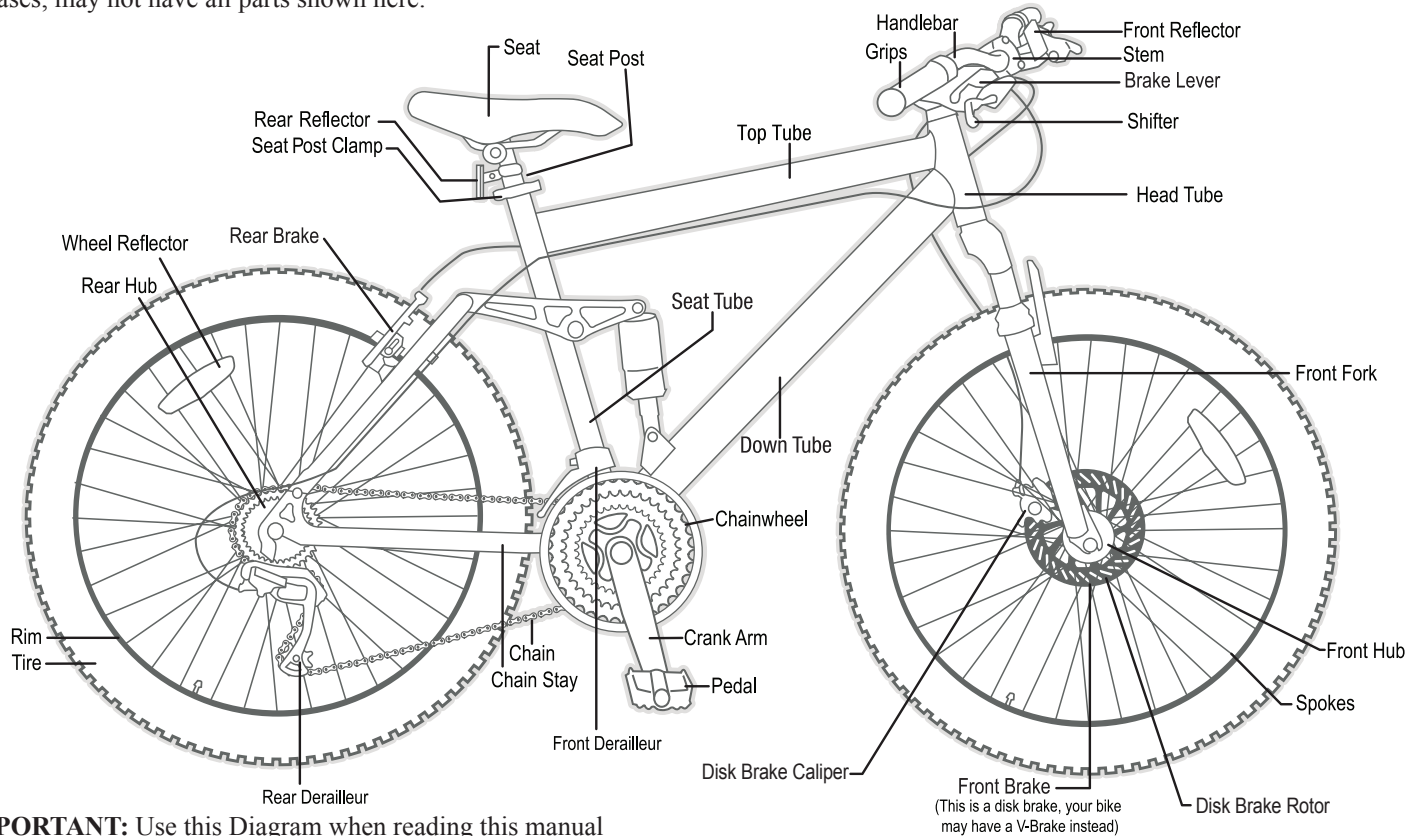

IMPORTANT: Use this Diagram when reading this manual to help you understand directions and instructions.

RULES OF THE ROAD

In the interest of safe cycling, make sure you read and understand the owner's manual.

In this manual you will find **DANGER**, **WARNING**, **CAUTION**, **IMPORTANT**, and **NOTE** or **NOTICE**. **These are important signal words telling you to pay special attention to that text as rider safety is involved.** **DANGER** and **WARNING**: Pay special attention to these since failure to do so could result in serious injury or death to the rider or others.

CAUTION: If not followed these instructions could result in injury or mechanical failure or damage to the bicycle.

NOTE or **NOTICE** or **IMPORTANT**: These specify something that is of special interest.

IMPORTANT Before you ride this bicycle, read this **RULES OF THE ROAD** section and check that all parts are installed and working as per this manual. If you understand how the bicycle operates, you will get the best performance. When you read this instruction book, compare the illustrations to the bicycle. Learn the location of all the parts and how they work.

Keep this book for future reference.

CAUTION Before you ride the bicycle, check the brake and other parts of the bike. Make sure all parts are tightened, assembled correctly and working properly. Take your first ride in a large, open, level area. If you have a problem, check the assembly instructions and follow the maintenance procedures in this book. **If you do not feel comfortable with your skills in assembling or adjusting the bike, please take it to a professional bike repairman.**

1. **WARNING - ON AND OFF ROAD CONDITIONS**: The condition of the riding surface is very important. If the surface is wet, or has sand, leaves, small rocks or other loose debris on the surface where you plan to ride, carefully decrease the speed of the bicycle and ride with extra caution. It will also take a longer time and more distance to stop. Apply the brake earlier than normal and with less force, rear brake first followed by the front brake if equipped, to help keep the bicycle from sliding or falling.

2. **NOTICE**: Most states require a full set of reflectors. Some state and local laws may require that your bike be equipped with a warning device, such as a horn or bell and most states require a light. Do NOT ride at night. Vision is quite limited at dawn, dusk and at night. If you must ride at night, take extra precautions, use front and rear lights, wear flashers on your arms, wear light-colored clothing, and plan your route to ride in well lighted areas.

3. Always wear shoes when riding a bicycle and avoid loose fitting clothes. Wear a cuff band or trouser clip to keep pants from getting caught in the chain wheel. Long sleeves, long pants, gloves, eye protection, a good helmet, elbow and knee pads are recommended.

Helmet use is required by law in many states and is always a good idea.

RULES OF THE ROAD *continued*

4. **CAUTION: WET WEATHER WARNING:** Check your brakes frequently. The ability to stop is critical. Roads are slippery in wet weather so avoid sharp turns and allow more distance for stopping. Brakes may become less efficient when wet. Leaves, loose gravel and other debris on the road can also affect stopping distance. If at all possible, do not ride in wet weather. Vision and control are impaired, creating a greater risk of accidents and injury.
5. **CAUTION:** A bicycle rider's best defense against accidents is to be alert to road conditions and traffic in the area. Do not wear anything that restricts your vision or your hearing.
6. When riding, **ALWAYS WEAR A CPSC APPROVED BIKE HELMET**
7. Obey all traffic regulations. Most traffic regulations apply to bike riders as well as automobile operators. Observe all state and local traffic regulations, signs and signals. Check with your local police station on bicycle licensing and inspection, and where it is legal to ride your bike.
8. Keep to the **RIGHT SIDE**. Follow the traffic flow in a straight line close to the curb. Watch out for opening car doors and cars moving in and out of traffic. Use caution at intersections and keep both hands on the handlebars.
9. Never carry passengers. This is dangerous and it makes the bicycle harder to control. Never carry packages that can hinder your vision or control of the bike or exceeds the max weight limit.
10. When riding in pairs or in larger groups, form a single line along the right side of the road. Set up a sensible distance between riders. Don't follow too closely.
11. Always be alert. Animals or people may dart in front of you. Give pedestrians the right-of-way. Don't ride too close to pedestrians, and don't park your bicycle where it can get in the way of foot/vehicle traffic.
12. Be careful at all intersections. Slow down and look both ways before crossing.
13. Use hand signals. Always let other drivers and pedestrians know what you are going to do. Signal 100 ft. before turning unless your hand is needed to control the bike.

RULES OF THE ROAD *continued*

14. **WARNING: NIGHT TIME OPERATION:** We do NOT recommend riding your bike at night. If you have an emergency that requires you to ride at night you must have proper lights and reflectors. NEVER ride at night without a helmet, taillight, a white front reflector, a red rear reflector, pedal reflectors and white wheel reflectors. You must be able to clearly see the surface where you are riding and be seen by others.
15. Cover your stem, handlebar, and top tube with safety pads for additional protection.
16. Never hitch rides. Never hold onto moving vehicles while riding. Never stunt ride or jump on your bike. Avoid head on impacts with curbs and other fixed objects.
17. **ON AND OFF ROAD OPERATION:** Avoid the following road hazards: drain grates, pot holes, ruts, soft road edges, gravel, leaves (especially when they are wet), uneven pavement, railroad crossings, manhole covers, curbs, speed bumps, puddles, and debris as all have an effect on your riding and may result in loss of control. Adjust your speed and the way you use your brakes if you must ride in such areas.
18. Do not ride your bicycle if the chain cover is not attached, or if any of the bicycle's mechanical systems are not functioning properly.
19. If any components become loose while riding, **(STOP!!)** immediately and tighten, or bring to a mechanic for repair.
20. If your bicycle is equipped with a quick release feature on the front and rear hubs, seat post, stem or accessory such as a trailer, or child carrier, it should be checked for proper assembly and tightness **BEFORE** each ride.

BEFORE RIDING:

Your new bicycle was assembled and tuned in the factory and then partially disassembled for shipping. The following instructions will enable you to prepare your bicycle for years of enjoyable cycling. For more details on inspection, lubrication, maintenance and adjustment of any area please refer to the relevant sections in this manual. **If you have questions about your ability to properly assemble this bicycle, please consult a professional bicycle mechanic before riding.**



TO AVOID INJURY, THIS PRODUCT MUST BE PROPERLY ASSEMBLED BEFORE USE. WE STRONGLY RECOMMEND THAT YOU REVIEW THE COMPLETE ASSEMBLY GUIDE AND PERFORM CHECKS SPECIFIED IN THE OWNER'S MANUAL BEFORE RIDING.

- 5/6mm hex wrench 
- Torque wrench
- Air pump & tire gauge to inflate tires
- Bicycle lubricant or grease

- 6" adjustable wrench
- Phillips & standard screwdrivers
- A pair of pliers with cable cutting ability

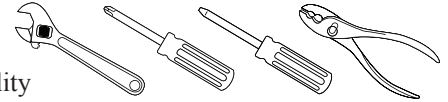

RECORD SERIAL NUMBER

Each bicycle has a serial number stamped into the bottom of the frame (See Illustration). Record this number HERE to keep for future reference. This number can be helpful to reclaim your bike if ever lost or stolen. **THIS INFORMATION IS ONLY AVAILABLE ON THE BIKE ITSELF.** There is no record of your serial number at the store purchased or with our company. It is your responsibility to record this information.

Serial Number: _____

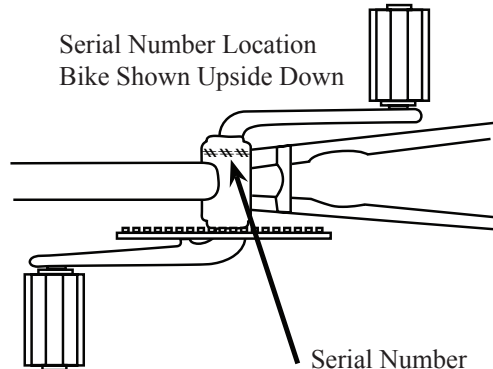



BEFORE EVERY RIDE:

Just a minute spent before each ride can significantly improve your safety and the enjoyment of your ride. So, each time before you ride make a habit of performing the following safety checks.

- Stand in front of the bicycle facing rearward and hold the front wheel securely between your legs. Try to twist the handlebar and verify that they do not move. Then pull the handlebars up, trying to lift the bike. There should be no movement.
- Try to push the front wheel from side to side and confirm that it feels tight and will not wobble. Lift the front wheel up by the handlebars and strike wheel downward with the heel of your hand and confirm that it is securely attached to the wheel. Spin the front wheel and confirm that it does not wobble or contact the fork or brake pads.
- Try to lift, push down on and twist the seat to confirm that it is tight.
- Look at the connection of the pedals to the crank arm. You should see no pedal screw threads and the pedal should feel firm and be parallel to the ground.
- Apply your brake(s) and make sure that they feel firm to the touch, and then spin the wheel(s). Apply the brakes. They should stop the wheel(s).
- Check to be sure that fenders and accessories are firmly attached and will not contact any moving parts. Make sure all reflectors are in position and not broken.

Now, put on your bicycle safety helmet and enjoy your ride. Your safety is well worth ***just a minute***. Also, be sure to read and follow the warnings and instructions in the Assembly, Maintenance and other sections of this manual.

CORRECT FRAME SIZE

When selecting a new bicycle, the correct choice of frame size is a very important safety consideration. The ideal clearance will vary between types of bicycles and rider preference. This makes straddling the frame when off the saddle easier and safer in situations such as sudden traffic stops. Women can use a man's bicycle to determine the correct size women's model.

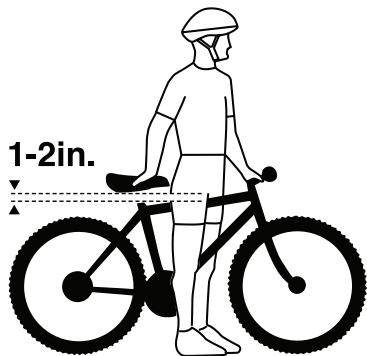

THERE SHOULD BE A CLEARANCE OF NO LESS THAN 1-2 INCHES BETWEEN THE GROIN AREA OF THE INTENDED RIDER AND THE TOP TUBE OF THE BICYCLE, WHILE THE RIDER STRADDLES THE BICYCLE WITH BOTH FEET FLAT ON THE GROUND.



THE SEATPOST “MINIMUM INSERTION” / “MAXIMUM HEIGHT” MARK SHOULD NOT BE VISIBLE WHEN THE SEAT POST IS INSERTED INTO THE SEAT MAST OF THE BIKE. DO NOT RAISE THE SEAT POST BEYOND THIS MARK. THE SEAT POST OR FRAME MAY BREAK CAUSING YOU TO LOSE CONTROL AND FALL. ALWAYS CHECK TO MAKE SURE SEAT POST ADJUSTING MECHANISM IS TIGHTENED SECURELY BEFORE RIDING.

RIDING POSITION

SADDLE HEIGHT

In order to obtain the most comfortable riding position and offer the best possible pedaling efficiency, the seat height should be set correctly in relation to the rider's leg length. The correct saddle height should not allow leg strain from over-extension, and the hips should not rock from side to side when pedaling. While sitting on the bicycle with one pedal at its lowest point, place the ball of your foot on the pedal. The correct saddle height will allow the knee to be slightly bent in this position.

REACH

To obtain maximum comfort, the rider should not over extend his or her reach when riding. There should be a slight bend in the rider's elbows. Refer to the section regarding seat and seat posts to learn how to adjust the seat post height.

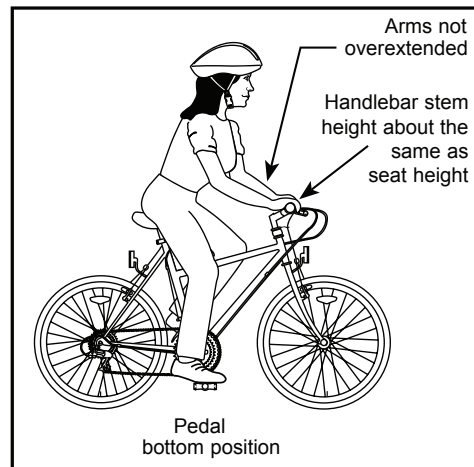

ASSEMBLING YOUR BIKE

PREPARATION

It is important that you read this owner's manual before you start to assemble your bicycle. **WE RECOMMEND THAT YOU CONSULT A PROFESSIONAL BICYCLE MECHANIC IF YOU HAVE DOUBTS OR CONCERNS AS TO YOUR ABILITY TO PROPERLY ASSEMBLE, REPAIR, OR MAINTAIN YOUR BICYCLE.** Remove all parts from the shipping carton. Check to make sure no parts are loose on the bottom of the carton. Carefully remove the front wheel which is attached to the side of the bicycle for shipping. Carefully remove all other packing material from the bicycle. This includes zip ties, axle caps and material protecting the frame.

FRONT WHEEL

1. Remove the nuts, washers and wheel retainers from the front wheel.
2. Slide the wheel onto the open ends of the fork. Slip an axle retainer onto each end of the axle, and hook the retainers into the holes in the fork end. Loosely install the washer onto each end of the axle (serrated end toward the retainer), then install the hex nut. (Note: there may be a washer head nut in place of the washer and hex nut).
3. Center the wheel in the fork and tighten the axle nuts securely, alternating from one side to the other to center the wheel.
4. Spin the wheel to make sure that it is centered in the fork and does not wobble. If the wheel is not centered, loosen the nuts and try again.
5. **If your bicycle has a quick release mechanism, read and follow the quick release information on this manual.**

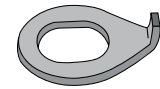
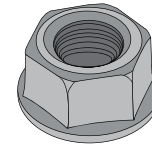
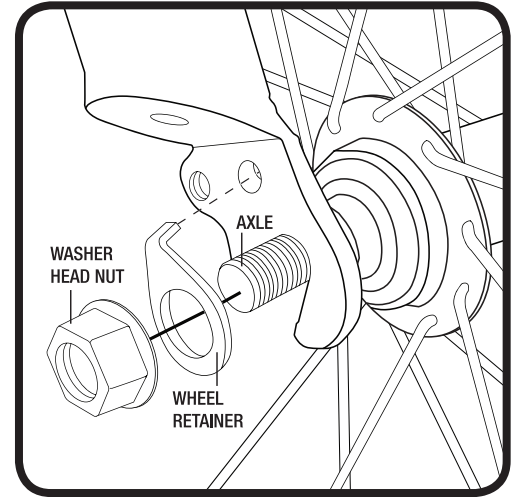

Torque requirement: 16-20 ft.. lbs.

QUICK RELEASE FRONT WHEEL

Some bicycles have wheel axles that incorporate a Quick Release (QR) mechanism. This allows easy wheel removal without the need for tools. The mechanism uses a long bolt (called a skewer) with an Adjusting Nut on one end, and a lever operating a cam-action tensioner on the other. With the quick release lever in the open position, insert the front wheel into the open ends of the fork. Turn the adjusting nut so that the locking lever is moved to the closed position with a firm action. At the halfway closed position of the quick release lever, you should start to feel some resistance to this motion. Do not tighten the quick release by using the quick release lever like a wing nut. If the quick release lever is moved to the closed position with little or no resistance, clamping strength is insufficient. Move the quick release lever to the open position, tighten the quick release adjusting nut, and return the quick release lever to the closed position.

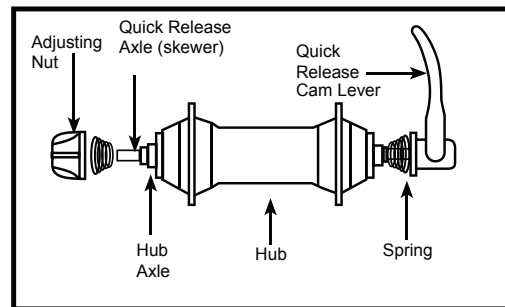

CORRECT QUICK RELEASE AXLE SETTING:

1. To set, turn the lever to the open position so that the curved part faces away from the bicycle.
2. While holding the lever in one hand, tighten the Adjusting Nut until it stops.
3. Pivot the lever toward the closed position. When the lever is halfway closed, there must be firm resistance to turn it beyond that point. If resistance is not firm, open the lever and tighten the Adjusting Nut in a clockwise direction.



WARNING! IF YOU ARE USING A UNIT EQUIPPED WITH A QUICK RELEASE, ALWAYS MAKE SURE THE QUICK RELEASE LEVER IS SECURELY CLOSED IN A LOCKED POSITION. ALSO BE CERTAIN YOUR QUICK RELEASE LEVER IS ON THE SIDE OPPOSITE TO THE DISC BRAKE IN YOUR UNIT.

4. Continue to move the lever all the way to the closed position so that the curved part of the lever faces the bicycle.
5. The Quick Release is open when you are able to read OPEN. Verify the Quick Release is closed when you are able to read CLOSED.
6. Repeat process until quick release lever is securely closed in a locked position.

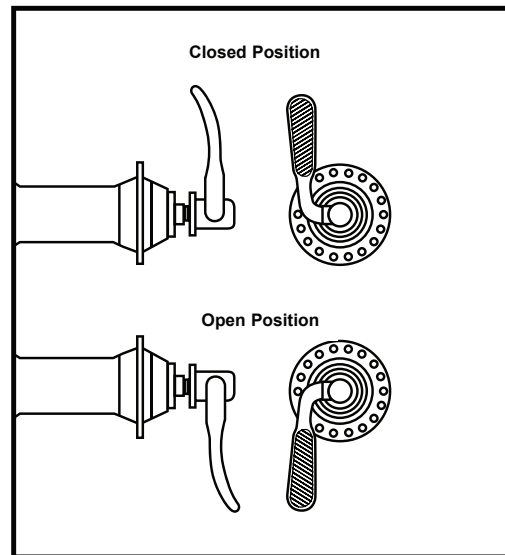

KICKSTAND

If your bike is equipped with a kickstand, please follow the instructions below.

1. Place the bicycle in an upright position.
2. Remove the top plate from the kickstand.
3. From the left side of the bicycle (opposite side from chainring), place the kickstand in position beneath the two rear fork legs.
4. Place the top plate, flange down, onto the mounting bolt.
5. Replace the washer and nut onto the mounting bolt. Hold the kickstand arm in an up position aligned with the frame stay, then securely tighten the mounting bolt.
6. Leave the leg of the kickstand down so it will support the bicycle during the rest of the assembly process.



WARNING! THE KICKSTAND IS DESIGNED TO SUPPORT THE BICYCLE ONLY, NOT THE BICYCLE AND RIDER.

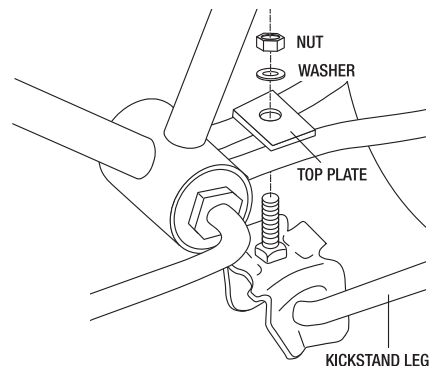

WARNING! Use your kickstand to support the bike when not riding. Allowing your bike to lay on it's side can damage the brake levers and cause an unsafe riding condition and could result in injury to the rider.

REAR MOUNT KICKSTAND

If your bike is equipped with a rear mount kickstand, please follow the instructions below:

1. Lean the bike against a wall for support, so that the right side (chainring side) is facing the wall and the left side of the bike is facing out.
2. Remove the rear axle nut and washer from the left side rear wheel.
3. Slide the kickstand plate onto the axle, so that it is seated against the rear dropout.
4. Slide the washer and nut back onto the axle and tighten securely.
5. Leave the leg of the kickstand down so it will support the bicycle during the rest of the assembly process.



WARNING! THE KICKSTAND IS DESIGNED TO SUPPORT THE BICYCLE ONLY, NOT THE BICYCLE AND RIDER.

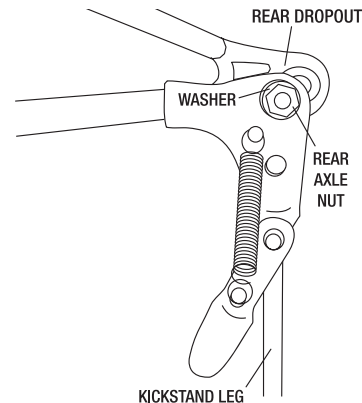

PEDAL INSTALLATION

1. Apply a small amount of grease to the threads of each pedal. Look for the letter “L” or “R” on the side or end of each pedal spindle (picture). Turning the spindle clockwise by hand (Picture), thread the pedal marked “R” into the crank arm on the right (drive) side of the bicycle. Make sure that you are not “cross-threading”, which can strip the threads in the crank arm. If the threads do not turn easily, don’t force them. Back the spindle out and start over. Once the pedal is threaded into the crank arm, tighten the spindle securely to the crank arm with a 15mm open end or an adjustable wrench.
2. Turning the spindle counterclockwise by hand, thread the pedal marked “L” into the crank arm on the left side of the bike. Make sure that you are not “cross-threading”, which can strip the threads in the crank arm. If the threads do not turn easily, don’t force them. Back the spindle out and start over. Once the pedal is threaded into the crank arm, tighten the spindle securely to the crank arm with a 15mm open end or an adjustable wrench.



WARNING! IMPROPERLY INSTALLED AND TIGHTENED PEDALS CAN WORK LOOSE, DAMAGING THE BICYCLE AND CAUSING POSSIBLE SERIOUS INJURY OR DEATH TO THE RIDER

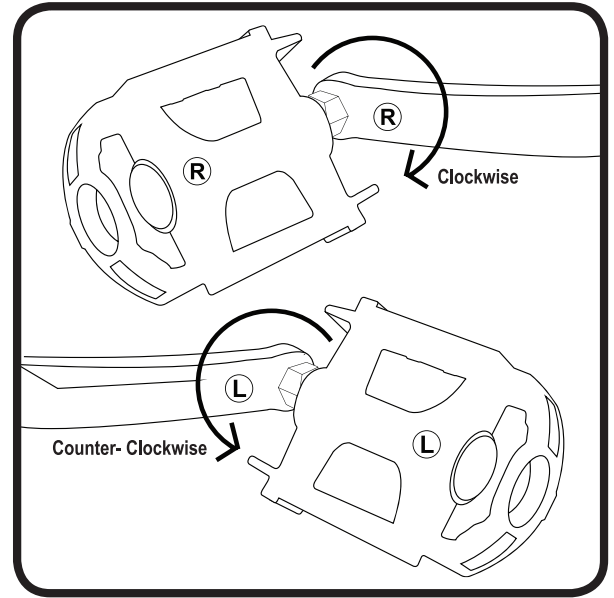

Torque Requirement 15-18 ft. lbs.

HANDLEBAR AND STEM INSTALLATION

QUILL STEM ASSEMBLY

1. Remove plastic packaging material covering the expander wedge.
2. Loosen the stem expander bolt, if necessary, so the wedge nut is in line with the stem body. See illustration.
3. Insert the stem into the head tube past the minimum insertion line indicated on the stem.

⚠ WARNING: THE HANDLEBAR STEM MUST BE INSERTED INTO THE HEAD TUBE UNTIL THE MINIMUM INSERTION LINE INDICATED ON THE STEM IS COMPLETELY COVERED.

4. Face the handlebar stem forward directly in line with the front wheel. **Make sure the fork is in the correct position (facing forward) before tightening the expander bolt.** See illustration on this page.
5. Tighten the expander bolt securely (turning in a clockwise direction). Recommended torque is 20 ft. lbs.

⚠ WARNING: THE ASSEMBLER IS CAUTIONED AGAINST THE DANGER OF DAMAGING THE HANDLEBAR STEM ASSEMBLY AND POSSIBLE INJURY TO THE RIDER IN OVERTIGHTENING THE EXPANDER BOLT AND EXPANDER WEDGE.

HANDLEBAR INSTALLATION

1. Remove the stem cap bolts and stem cap.
2. Insert the handlebar into the stem.
3. Reattach the stem cap by tightening the stem cap bolts equally. Note the distance between the stem and stem cap should be equal on top and bottom of the cap.
4. Check the handlebar for tightness. If you can move it forward or backward, the cap bolt is not tight enough.
5. Check steering by straddling the front wheel and trying to turn the handlebar. If you can turn the handlebar without turning the front wheel. The stem is too loose. Align the handlebar with the front wheel. Retighten the expander bolt (clockwise).

Recommended torque is 15 ft. lbs.

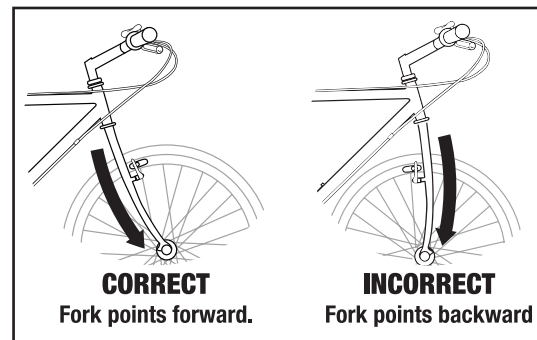
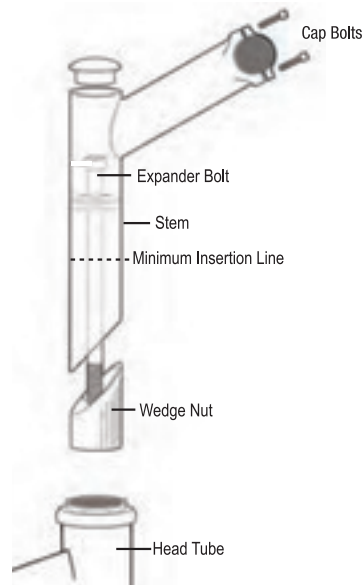

HANDLEBAR AND STEM INSTALLATION

A-HEAD STEM ASSEMBLY

⚠️ WARNING! ALWAYS TIGHTEN FASTENERS TO THE CORRECT TORQUE. BOLTS THAT ARE TOO TIGHT CAN DEFORM. BOLTS THAT ARE TOO LOOSE CAN MOVE AND FATIGUE. EITHER MISTAKE CAN LEAD TO LOSS OF CONTROL, SERIOUS INJURY OR DEATH. IF YOU DO NOT FEEL COMFORTABLE WITH YOUR SKILLS IN ASSEMBLING OR ADJUSTING THE BIKE, PLEASE TAKE IT TO A PROFESSIONAL BIKE REPAIRMAN.

1. **Make sure the front fork is facing forward (see illustration).**
 2. Insert the stem onto the fork steerer tube. Align the steerer tube so that it sits ABOVE the top allen screw, but BELOW the top of the stem.
 3. Tighten the 5mm head set top cap bolt to a torque of 15 ft. lbs. **Do Not Overtighten!**
 4. Face the handlebar stem forward directly in line with the front wheel.
- Tighten the two 5mm allen screws on the handlebar stem to a torque of 7 ft. lbs.

⚠️ WARNING! FAILURE TO PROPERLY TIGHTEN HANDLEBAR COMPONENTS MAY RESULT IN LOSS OF CONTROL, SERIOUS INJURY OR DEATH. ALWAYS CHECK THE HANDLEBAR CANNOT MOVE AND IS SECURED TO THE FRAME BEFORE RIDING THE BICYCLE.

HANDLEBAR INSTALLATION

1. Remove the stem clamp bolts and stem cap.
2. Insert the handlebar into the stem.
3. Reattach the stem cap by tightening the stem clamp bolts equally. Note the distance between the stem and stem cap should be equal on top and bottom of the cap. Recommended torque is 15 ft. lbs.
4. Check the handlebar for tightness. If you can move it forward or backward, the clamp bolts are not tight enough.
5. Check steering by straddling the front wheel and trying to turn the handlebar. If you can turn the handlebar without turning the front wheel. The stem is too loose. Align the handlebar with the front wheel. Retighten the top cap bolt and allen screws.

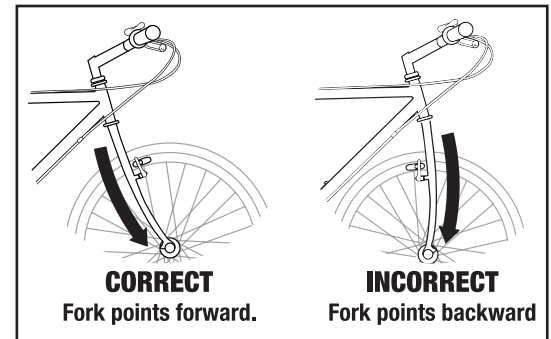
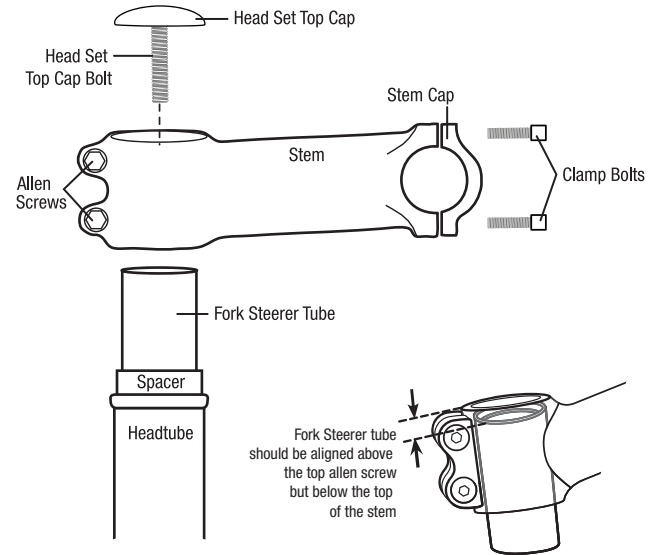

SEAT & SEAT POST ASSEMBLY

1. Loosen the seat clamp nuts.
2. Insert the top portion of the seat post into the seat clamp. Be sure the seat post is completely inserted into the seat clamp and butted tightly against the underside of the seat.
3. Tighten seat clamp nuts securely.
4. Insert the seat post (with seat attached) into the bike frame. Be sure that the seat post is inserted past the minimum insertion line.
5. Tighten the seat post binder bolt securely at the desired height.
6. Adjust the angle of the seat so that the top of the seat is parallel to the ground or comfortable to the rider.
7. Retighten the seat clamp nuts securely. Check for tightness by attempting to twist the seat. If the seat is loose, be sure to tighten the clamp nuts and binder bolt securely. Torque requirement 15-20 ft.. lbs.

⚠ THE SEATPOST “MINIMUM INSERTION” / “MAXIMUM HEIGHT” MARK SHOULD NOT BE VISIBLE WHEN THE SEAT POST IS INSERTED INTO THE SEAT MAST OF THE BIKE. DO NOT RAISE THE SEAT POST BEYOND THIS MARK. THE SEAT POST OR FRAME MAY BREAK CAUSING YOU TO LOSE CONTROL AND FALL.

ALWAYS CHECK TO MAKE SURE SEAT POST ADJUSTING MECHANISM IS TIGHTENED SECURELY BEFORE RIDING. RIDING WITH AN IMPROPERLY TIGHTENED SEAT POST CAN ALLOW THE SEAT TO TURN OR MOVE AND CAUSE THE RIDER TO LOSE CONTROL

SADDLE HEIGHT: In order to obtain the most comfortable riding position and offer the best possible pedaling efficiency, the seat height should be set correctly in relation to the rider’s leg length. The correct saddle height should not allow leg strain from over-extension, and the hips should not rock from side to side when pedaling. While sitting on the bicycle with one pedal at it’s lowest point, place the ball of your foot on the pedal. The correct saddle height will allow the knee to be slightly bent in this position. To obtain maximum comfort, the rider should not over extend his or her reach when riding. There should be a slight bend in the rider’s elbows.

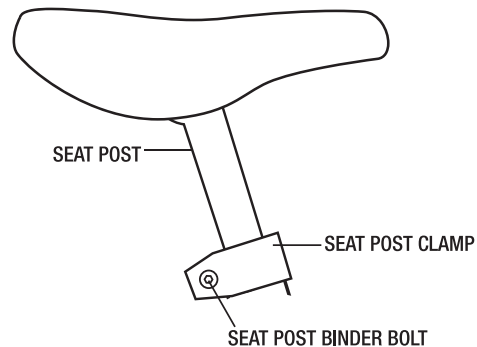
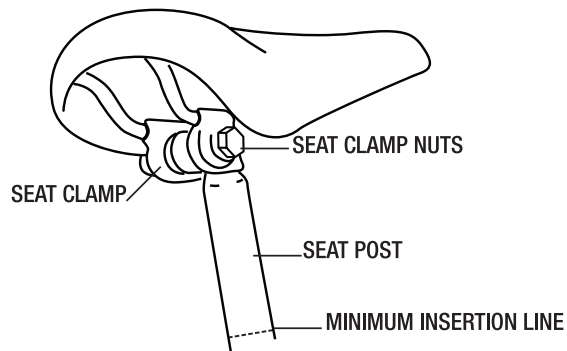

SEAT & QUICK RELEASE SEAT POST ASSEMBLY

1. Loosen the seat clamp nuts.
2. Insert the top portion of the seat post into the seat clamp. Be sure the seat post is completely inserted into the seat clamp and butted tightly against the underside of the seat.
3. Tighten seat clamp nuts securely.
4. Insert the seat post (with seat attached) into the bike frame. Be sure that the seat post is inserted past the Minimum Insertion Line.
5. Tighten the tension adjusting nut by hand and move the quick release lever to the closed position. NOTE: Less than half a turn of the tension adjusting nut can make the difference between safe clamping force and unsafe clamping force. You should feel considerable resistance while moving the lever. If not, re-open and retighten the lever, then move it to the closed position so it is in line with the top tube of the frame (as shown in the top illustration).
6. Adjust the angle of the seat so that the top of the seat is parallel to the ground or comfortable to the rider.
7. Retighten the seat clamp nuts securely. Check for tightness by attempting to twist the seat. If the seat is loose, be sure to tighten the clamp nuts and binder bolt securely. Torque requirement 15-20 ft. lbs.

⚠ THE SEATPOST “MINIMUM INSERTION” / “MAXIMUM HEIGHT” MARK SHOULD NOT BE VISIBLE WHEN THE SEAT POST IS INSERTED INTO THE SEAT MAST OF THE BIKE. DO NOT RAISE THE SEAT POST BEYOND THIS MARK. THE SEAT POST OR FRAME MAY BREAK CAUSING YOU TO LOSE CONTROL AND FALL.

ALWAYS CHECK TO MAKE SURE SEAT POST ADJUSTING MECHANISM IS TIGHTENED SECURELY BEFORE RIDING. RIDING WITH AN IMPROPERLY TIGHTENED SEAT POST CAN ALLOW THE SEAT TO TURN OR MOVE AND CAUSE THE RIDER TO LOSE CONTROL AND FALL.

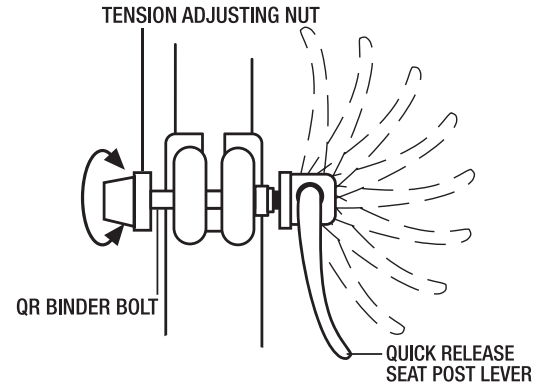
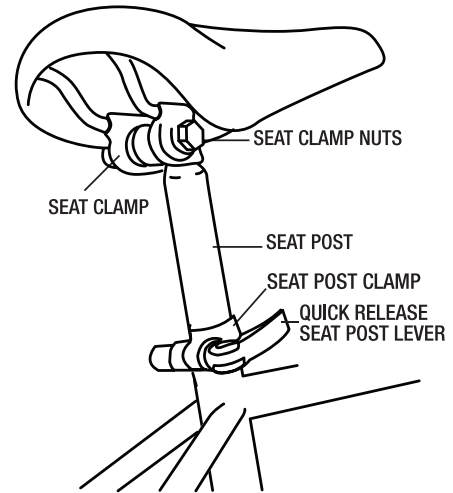

HAND BRAKES

Determine which type of brake your bike is equipped with and refer to the appropriate assembly instructions. If your bike comes equipped with a foot brake ONLY, no brake adjustment is required. For more information on brake adjustment and maintenance, refer to the maintenance section of this manual.

NOTE: A greater force is required to activate the rear brake due to longer cable length. It is important to become familiar with the use of hand brakes. When properly adjusted, hand brakes are an efficient braking system. Keep the rim and brake shoes clean and free from wax, lubricants and dirt at all times. Keep brakes properly adjusted and in good working condition at all times.

Open the brake lever and place the cable head end of the short brake cable into the lever, then close the lever. Secure the ferrule against the lever using the cable adjusting barrel.

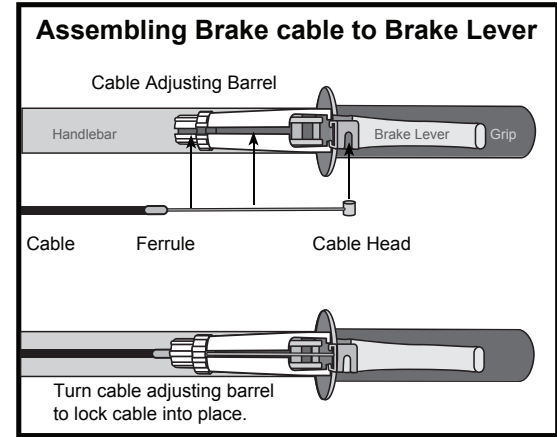

SIDE PULL CALIPER BRAKE

Loosen the cable anchor nut and thread the brake cable through it. Tighten the nut by hand until it holds the cable in place. Squeeze the brake arms together against the rim of the wheel. Loosen the nuts on the brake shoes and turn until they match the angle of the rim. Tighten the nuts securely. Pull down on the end of the brake cable with pliers, hold taut and securely tighten the cable anchor nut. Spin the wheel, the brake shoes should not contact the rim at any point and should be an equal distance from the rim on both sides. Make sure all nuts and bolts are securely tightened. Test the brake levers 20-25 times to take care of any initial cable stretch. Be sure to tightly secure the brake fixing nut behind the fork.

⚠ WARNING! WHEN ASSEMBLING OR ADJUSTING THE BRAKES, MAKE SURE THE CABLE ANCHOR IS TIGHT. FAILURE TO SECURELY TIGHTEN THE NUT COULD RESULT IN BRAKE FAILURE AND PERSONAL INJURY.

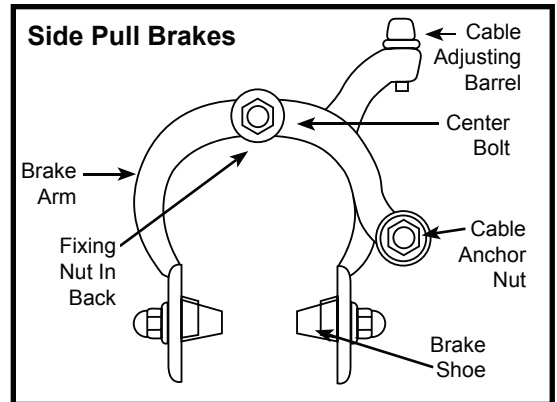

V-BRAKE ASSEMBLY & ADJUSTMENT

If not already assembled, take the brake noodle from the parts box and slide the cable through the larger opening. The cable housing will then seat into the end of the noodle. Slide the cable through the cable lead on the end of the left brake arm, this will cause the noodle to fit into the lead. Slip the brake cable boot over the cable and position it between both brake arms. Next, loosen the 5mm anchor bolt at the end of the right brake arm and slide the cable under the retaining washer. Pull the slack out of the cable making sure a distance of 39mm or more remains between the end of the lead and the start of the anchor bolt. Once the cable is secured to the brake arms, engage the brake lever several times, checking the position of the brake shoes at the rim. The brake shoes should be 1mm away from the rim when in a relaxed position. When the brake lever is engaged, the brake shoe should hit the rim flush (never the tire) with the front brake pad touching the rim slightly before the rear. This is called “toeing-in” your brake shoe. If this position is not achieved, adjustments to the brake shoe are required. Loosen the brake shoe hardware and reposition the brake shoe. It may take several shoe and cable adjustments before the required position is accomplished.

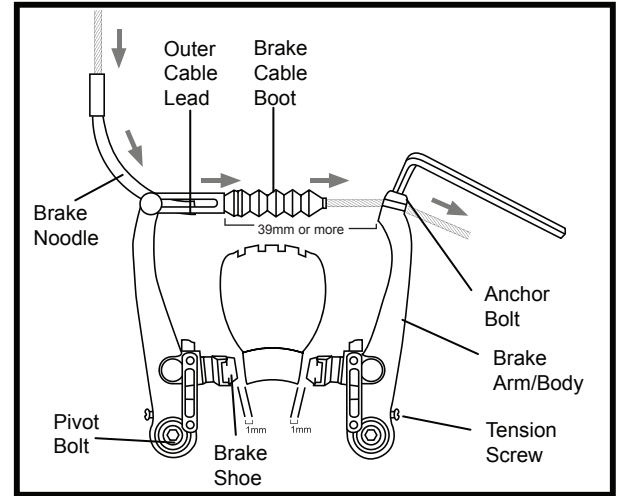

V-BRAKE *continued*

1. If fitted with V-Brakes, insert the brake body into the center spring hole in the frame mounting boss, and then secure the brake body to the frame with the link fixing bolt.

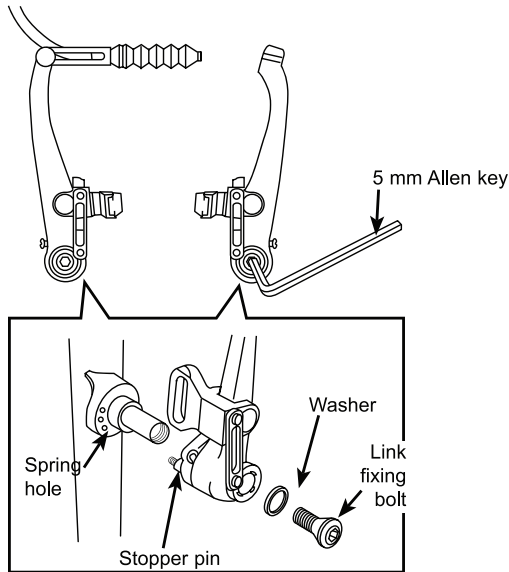

2. While holding the shoe against the rim, adjust the amount of shoe protrusion by interchanging the position of the B washers (i.e. 6 mm and 3 mm) so that dimension A is kept at 39 mm or more.

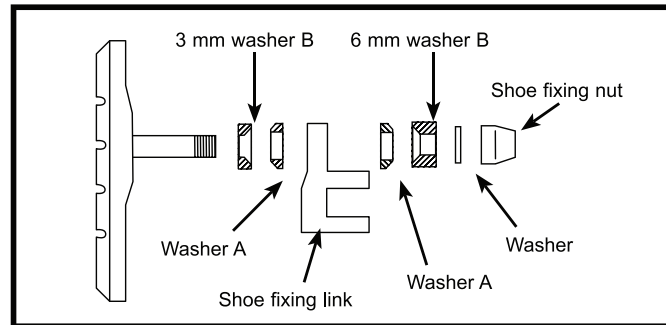
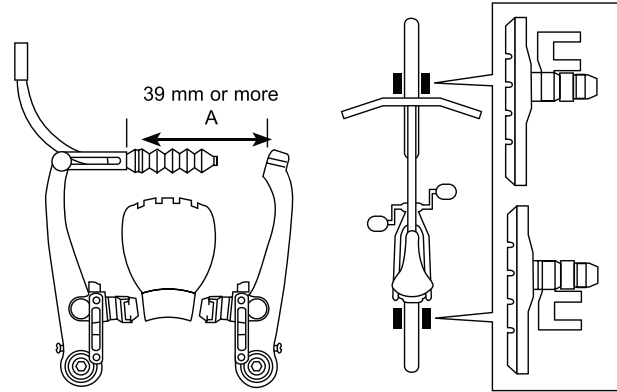

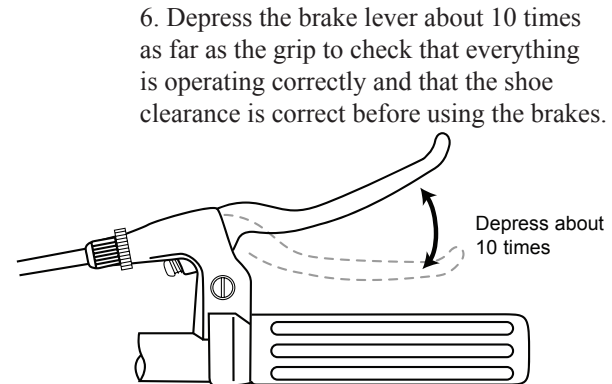
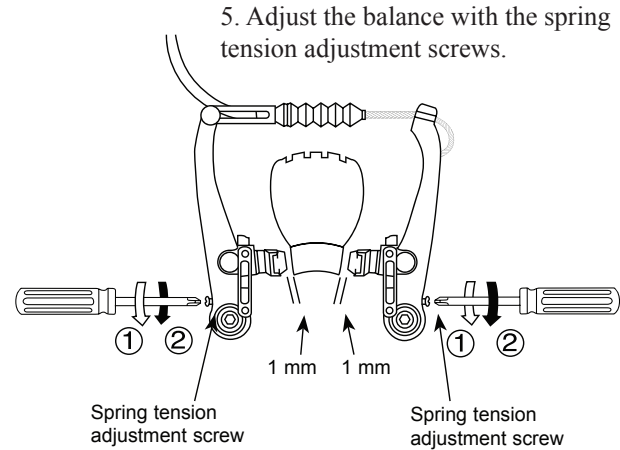
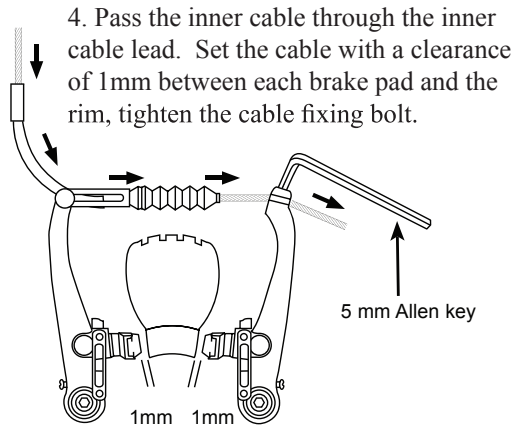
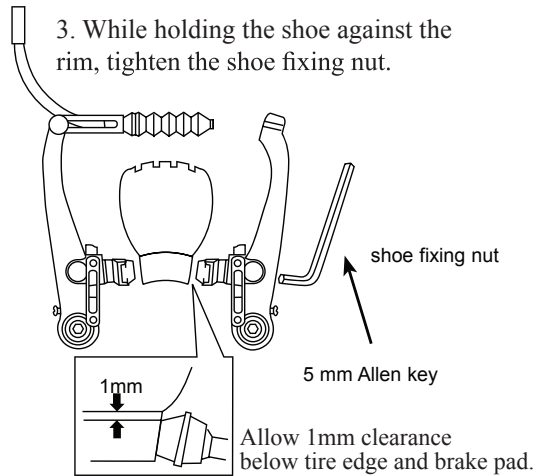

DISC BRAKES

We suggest that if your bike comes equipped with a disc brake that you consult a professional bicycle mechanic for any adjustments or repair needed for this brake.

SAFETY PRECAUTIONS

1. Adjust the inner cable so that the protruding length is less than 20mm. If the protruding length is any longer, the end of the cable may become stuck in the rotor, which could cause the wheel to lock and the bicycle could fall forward causing injuries.
2. The calipers and rotor will become hot when the brakes are operated, so do not touch them while riding or immediately after dismounting from the bicycle, you may get burned. Check that the brake components have cooled down before attempting to adjust the brakes.
3. Always make sure that the front and rear brakes are working correctly before you ride the bicycle.
4. Before riding the bicycle, check that the pad thicknesses are 0.5mm or more.
5. If noise occurs when the brakes are operated, it may indicate that the brake pads have worn down to their usage limit. After checking that the brake system has cooled down sufficiently, check the brake pad thickness. Replace the brake pads if the wear indicators are visible.
6. Be careful not to allow any oil or grease to get onto the rotor and brake pads, otherwise the brakes may not work correctly.
7. Check the brake cable for rust and fraying, and replace the cable immediately if such problems are found. If this is not done, the brakes may not work correctly.
8. The required braking distance will be longer during wet weather. Reduce your speed and apply the brakes early and gently.

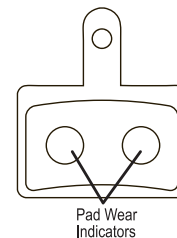
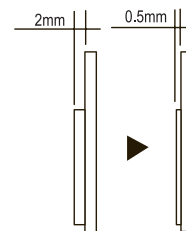
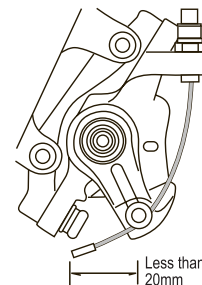

DISC BRAKES *continued*

9. If the road surface is wet, the tires will skid more easily. If the tires skid, you may lose control of the bicycle. To avoid this, reduce your speed and apply the brakes gently.

10. Check that the quick release lever is on the right side (the opposite side to the rotor). If the quick release lever is on the same side as the rotor, there is a danger that the lever may interfere with the rotor causing a sudden stop, which may result in a serious accident. Make sure that it does not interfere by rotating the wheel and making sure it rotates freely. Make sure wheel is securely tightened to forks.

11. It is important to completely understand the operation of your bicycle's brake system. Improper use of your brake system may result in loss of control or an accident, which could lead to severe injury. Because each bicycle may handle differently be sure to learn proper braking technique (including brake lever pressure and bicycle control characteristics) and operation of your bicycle. This can be done by consulting a professional bicycle mechanic and referring to the disk brake instruction sheet included with your bike. This can also be done by practicing your braking technique in a safe area before hitting the trails.

CAUTION: Disc brakes have a burn-in period, and the braking force will gradually increase as the burn-in period progresses. Make sure that you are aware of any such increases in braking force when using the brakes during the burn-in period. The same thing will happen when the brake pads or rotor are replaced.

DISC BRAKES

If the brake cable is not connected at the brake lever, line up brake barrel slot with brake lever slot before installing the cable. Slide the head of the brake cable into the brake lever per the diagram. Thread the cable through the slot in the brake lever so the cable end rests squarely in the adjusting barrel. Turn the adjusting barrel to close. (See pg. 20)

If the brake cable is disconnected at the disc caliper, thread the brake wire through the adjustment barrel, loosen the cable anchor bolt until you can see a hole through the anchor bolt for the cable wire to attach. Thread the cable wire through the cable anchor and tighten by hand.

Centering brake - First determine if the wheel is centered. Look at the space between the tire and the frame on either side. If it is not even, loosen the wheel axle nuts and center the wheel, then proceed to center the brake.

If the brake is not centered, look at the disc brake caliper for centering adjustment screws at the center of the brake pad on either side. Looking down into the brake where the brake pads contact the disc rotor, determine which side needs to move away or towards the disc. Turn the centering adjustment screws so that there is about 1/32 of an inch of clearance on either side of the disc rotor. Spin the front wheel and listen for any rubbing noise or excess friction. Repeat the steps until the brake is centered.

Brake is correctly adjusted when:

- The brake pads do not drag on the rotor when the brake is open.
- When the brake is applied, the brake pads contact the rim before the brake lever reaches about 1/3 of the way to the handlebar.

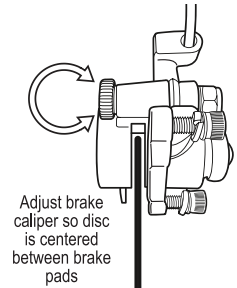
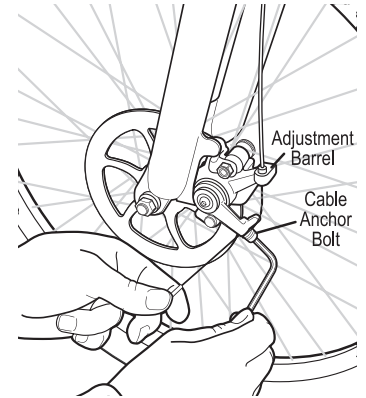
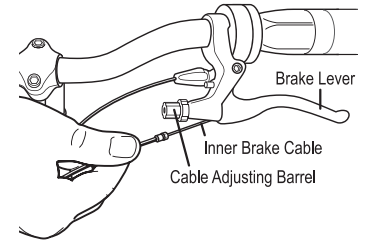

DISC BRAKES *continued*

After adjusting the brake, reinspect the brake pads, centering, and brake lever travel. If the brake pads are no longer square to the rim, repeat brake pad adjustments. Be sure that the brake pads return to a centered position by spinning the wheel and listening for the brake pad rubbing the rotor on either side. Readjust as needed. Check that the brake cable tension allows the brake lever about 1/3 of the travel before the brake pads contact the rotor. If the cable has stretched or slipped, readjust brake cable tension by loosening the cable anchor bolt and pulling more cable through the anchor or use the brake adjustment barrel for fine tuning the brake cable tension.



WARNING! DISC GETS HOT! SEVERE INJURY COULD RESULT FROM CONTACT WITH THE HOT DISC. ALLOW DISC TO COOL COMPLETELY BEFORE TOUCHING.

Tires and Tubes

After assembling your bike, it will be necessary to inflate the tires. Check the sidewall of the tire for the correct tire pressure (PSI) and inflate tires accordingly with a **MANUAL BICYCLE PUMP**. **Improper inflation is the biggest cause of tire failure. Due to the slightly porous nature of bicycle inner tubes, it is normal for your bike tires to lose pressure over time. For this reason it is critically important to maintain the proper tire inflation on your bike.**

1. Your bicycle has been equipped with tires which the bike's manufacturer felt were the best balance of performance and value for the use for which the bike was intended. The tire size and pressure rating are marked on the sidewall of the tire. **CAUTION:** Pencil type automotive tire gauges and gas station air hose pressure settings can be inaccurate and should not be relied upon for consistent, accurate pressure readings. Instead, use a high quality dial gauge.

⚠ WARNING: NEVER INFLATE A TIRE BEYOND THE MAXIMUM PRESSURE MARKED ON THE TIRE'S SIDEWALL. EXCEEDING THE RECOMMENDED MAXIMUM PRESSURE MAY BLOW THE TIRE OFF THE RIM, WHICH COULD CAUSE DAMAGE TO THE BIKE AND INJURY TO THE RIDER AND OTHERS. THE BEST WAY TO INFLATE A BICYCLE TIRE TO THE CORRECT PRESSURE IS WITH A BICYCLE PUMP. NEVER USE A SERVICE STATION AIR HOSE TO INFLATE A BICYCLE TIRE. IT IS DESIGNED FOR LARGER TIRES AND IT CAN EXCEED THE RECOMMENDED MAXIMUM PRESSURE AND IT MAY BLOW THE TIRE OFF THE RIM.

Tire pressure is given either as maximum pressure or as a pressure range. How a tire performs under different terrain or weather conditions depends largely on tire pressure. Inflating the tire to near its maximum recommended pressure gives the lowest rolling resistance; but also produces the harshest ride. High pressures work best on smooth, dry pavement. Very low pressures, at the bottom of the recommended pressure range, give the best performance on smooth, slick terrain such as hard-packed clay, and on deep, loose surfaces such as deep, dry sand. Tire pressure that is too low for your weight and the riding conditions can cause a puncture of the tube by allowing the tire to deform sufficiently to pinch the inner tube between the rim and the riding surface.

Some special high-performance tires have unidirectional treads: their tread pattern is designed to work better in one direction than in the other. The sidewall marking of a unidirectional tire will have an arrow showing the correct rotation direction. If your bike has unidirectional tires, be sure that they are mounted to rotate in the correct direction.

2. The tire valve allows air to enter the tire's inner tube under pressure, but doesn't let it back out unless you want it to. There are primarily two kinds of bicycle tube valves: The Schraeder Valve and the Presta Valve. The bicycle pump you use must have the fitting appropriate to the valve stems on your bicycle. The Schraeder is like the valve on a car tire, this is the type of valve stem you should have on your bike. To inflate a Schraeder valve tube, remove the valve cap and push the air hose or pump fitting onto the end of the valve stem. To let air out of a Schraeder valve, depress the pin in the end of the valve stem with the end of a key or other appropriate object.

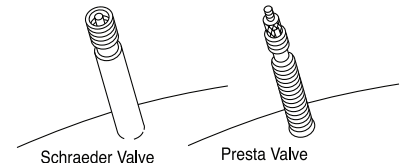

REFLECTORS

Your bike is supplied with one front (white), one rear (red), two wheel (white) reflectors and four pedal (orange) reflectors. These are an important safety and legal requirement, and should remain securely fitted and in good condition at all times. Periodically, inspect all reflectors, brackets and mounting hardware for signs of wear or damage. Replace immediately if damage is found. Some bicycles will require you to install your reflectors onto your bicycle. Please refer to the following section for instructions on all types of bicycle reflectors.

⚠ WARNING! REFLECTORS ARE IMPORTANT SAFETY DEVICES WHICH ARE DESIGNED AS AN INTEGRAL PART OF YOUR BICYCLE. FEDERAL REGULATIONS REQUIRE EVERY BICYCLE TO BE EQUIPPED WITH FRONT, REAR, WHEEL, AND PEDAL REFLECTORS. THESE REFLECTORS ARE DESIGNED TO PICK UP AND REFLECT STREET LIGHTS AND CAR LIGHTS IN A WAY THAT HELPS YOU TO BE SEEN AND RECOGNIZED AS A MOVING BICYCLIST. CHECK REFLECTORS AND THEIR MOUNTING BRACKETS REGULARLY TO MAKE SURE THEY ARE CLEAN, STRAIGHT, UNBROKEN AND SECURELY MOUNTED. HAVE YOUR DEALER REPLACE DAMAGED REFLECTORS AND STRAIGHTEN OR TIGHTEN ANY THAT ARE BENT OR LOOSE.

FORK MOUNT REFLECTORS

First insert one washer onto the hex bolt and insert hex bolt through the reflector bracket and then through the fork. Next, insert a second washer onto the bolt and thread a hex nut onto the bolt behind the fork. Tighten bolts until snug, making sure the reflector is in an upright position.

CAUTION: Be sure the reflector is vertical to the ground. If the reflector is aimed up or down, oncoming headlights may not reflect properly in the reflector.

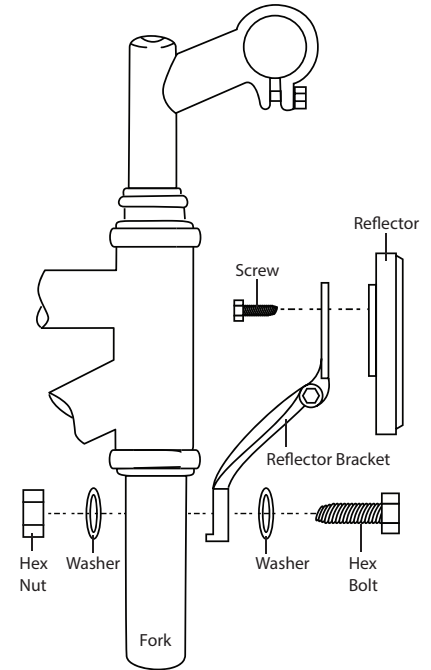

FRONT REFLECTOR MOUNT WITH CALIPER BRAKE ASSEMBLY

First remove the hex nut from the back of the fork and pull the brake from the fork. Insert a spacer, washer and reflector bracket on to the caliper bolt. Insert the caliper bolt back into the fork and secure firmly with a concave spacer, washer and hex nut. Finally, adjust the reflector such that it is in an upright position. Tighten bolts until snug.

CAUTION: Be sure the reflector is vertical to the ground. If the reflector is aimed up or down, oncoming headlights may not reflect properly in the reflector.

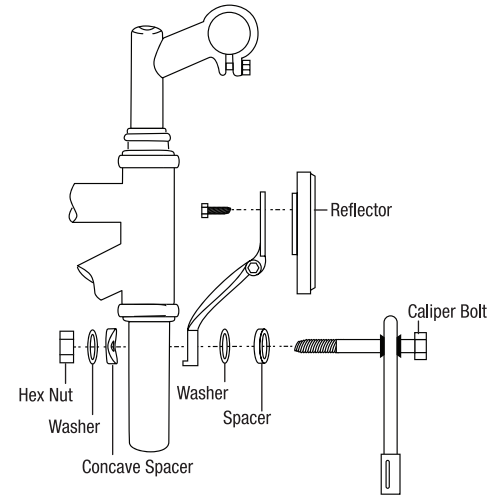

FRONT REFLECTOR MOUNT ON HANDLEBAR

1. Remove the clamp screw from the reflector bracket.
2. Push open the bracket loop and slide in over the handlebar tube. If there is a sizing insert included with the bracket, please be sure it is inside the clamp loop before mounting.
3. Position the reflector bracket on the handlebar between the grip and crossbar, about 5" from the end of the handlebar.
4. Tighten the clamp screw securely.

CAUTION: Be sure the reflector is vertical to the ground. If the reflector is aimed up or down, oncoming headlights may not reflect properly in the reflector.

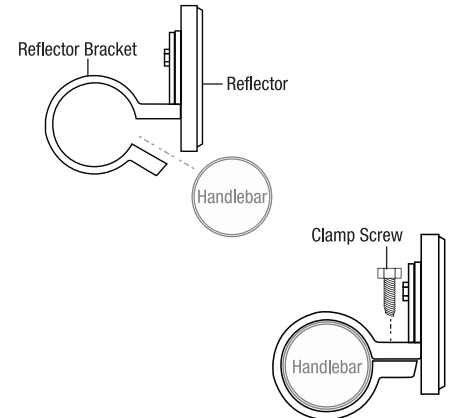

REAR REFLECTOR MOUNT ON SEAT POST

First attach the reflector to the bracket with the reflector screw, see the top diagram. Next, remove the clamp screw and open the clamping reflector bracket. Place clamping reflector bracket around the seat post. If the clamp is too loose, insert the shim inside the clamp. Tighten the clamp screw to hold the reflector assembly in place. Finally adjust the reflector assembly in place and ensure that it is upright and facing away from the bike.

CAUTION: Be sure the reflector is vertical to the ground. If the reflector is aimed up or down, oncoming headlights may not reflect properly in the reflector.

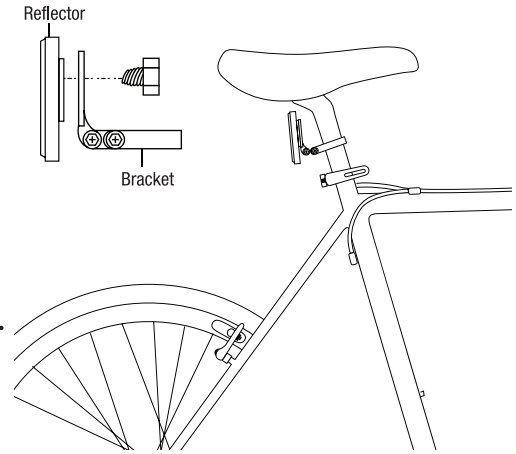

REAR REFLECTOR MOUNT ON SEAT STAY BRACKET

First insert one washer onto the hex bolt and insert hex bolt through the reflector bracket and then through the seat stay bridge bracket. Next, insert a second washer onto the bolt and thread a hex nut onto the bolt behind the seat stay bridge bracket. Tighten bolts until snug. Finally adjust the reflector assembly in place and ensure that it is upright and facing away from the bike.

CAUTION: Be sure the reflector is vertical to the ground. If the reflector is aimed up or down, oncoming headlights may not reflect properly in the reflector.

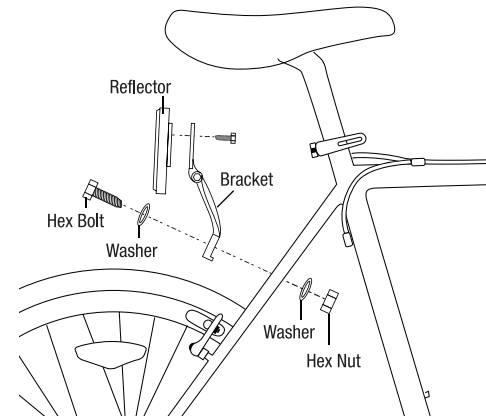

SUSPENSION FRAMES

Full Suspension bikes are equipped with a front suspension fork as well as a rear suspension on the frame, below the seat. The piston works in conjunction with a spring to allow the bike to rotate on a pivot point. Ensure all attaching hardware is secured and there is no lateral movement of the rear triangle. On some bicycles the amount of rear suspension travel may be adjustable by turning the adjusting plate. Clockwise will increase spring tension and decrease travel, while turning counter-clockwise will decrease spring tension and increase travel.

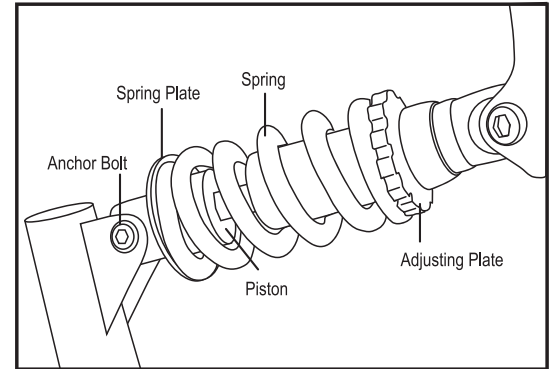

⚠ WARNING!
THERE MUST BE ENOUGH TENSION ON THE SPRING TO HOLD THE SPRING PLATE IN PLACE. FAILURE TO DO THIS MAY CAUSE THE MECHANISM TO FAIL. FAILURE TO MAINTAIN, CHECK AND PROPERLY ADJUST THE SUSPENSION SYSTEM MAY RESULT IN SUSPENSION MALFUNCTION, WHICH CAN CAUSE YOU TO LOSE CONTROL AND FALL. CHANGING SUSPENSION ADJUSTMENT CAN CHANGE THE HANDLING AND BRAKING CHARACTERISTICS OF YOUR BICYCLE. NEVER CHANGE SUSPENSION ADJUSTMENT UNLESS YOU ARE THOROUGHLY FAMILIAR WITH THE SUSPENSION SYSTEM, MANUFACTURER'S INSTRUCTIONS AND RECOMMENDATIONS, AND ALWAYS CHECK FOR CHANGES IN THE PERFORMANCE OF YOUR BICYCLE BY TAKING A CAREFUL TEST RIDE IN A HAZARD FREE AREA. IF YOUR BIKE HAS SUSPENSION EQUIPMENT, THE INCREASED SPEED YOU MAY DEVELOP ALSO INCREASES YOUR RISK. WHEN BRAKING, THE FRONT OF A SUSPENDED BIKE DIPS. YOU COULD LOSE CONTROL OF THE BICYCLE AND FALL. GET TO KNOW HOW TO HANDLE YOUR SUSPENSION SYSTEM SAFELY BEFORE TRYING ANY DOWNHILL OR VERY FAST BIKING.

SHIFTING GEARS

If your bike is a multi-speed bike, please read the information below to familiarize yourself with the basics of shifting gears.

Your multi-speed bicycle will have a derailleur drivetrain (see 1. below), an internal gear hub drivetrain (see 2. below) or, in some special cases, a combination of the two.

1. How A Derailleur Drivetrain Works

If your bicycle has a derailleur drivetrain, the gear-changing mechanism will have:

- a rear cassette or freewheel sprocket cluster
- a rear derailleur
- usually a front derailleur
- one or two shifters
- one, two or three front sprockets called chainrings
- a chain

a. A Brief Note About Shifting Gears

There are several different types and styles of shifting controls: levers, twist grips, triggers, combination shift/brake controls, push-buttons, and so on. If you are not comfortable shifting gears, ask your local bike mechanic to explain the type of shifting controls that are on your bike, and to show you how they work. The vocabulary of shifting can be pretty confusing. A downshift is a shift to a “lower” or “slower” gear, one which is easier to pedal. An upshift is a shift to a “higher” or “faster”, harder to pedal gear. What’s confusing is that what’s happening at the front derailleur is the opposite of what’s happening at the rear derailleur (for details, read the instructions on Shifting the Rear Derailleur and Shifting the Front Derailleur below). For example, you can select a gear which will make pedaling easier on a hill (make a downshift) in one of two ways: shift the chain down the gear “steps” to a smaller gear at the front, or up the gear “steps” to a larger gear at the rear. So, at the rear gear cluster, what is called a downshift looks like an upshift. The way to keep things straight is to remember that shifting the chain in towards the centerline of the bike is for accelerating and climbing and is called a downshift. Moving the chain out or away from the centerline of the bike is for speed and is called an upshift. Whether upshifting or downshifting, the bicycle derailleur system design requires that the drive chain be moving forward and be under at least some tension. A derailleur will shift only if you are pedaling forward.

CAUTION: Never move the shifter while pedaling backward, nor pedal backward immediately after having moved the shifter. This could jam the chain and cause damage to the bicycle.

b. Shifting The Rear Derailleur

The rear derailleur is controlled by the right shifter. The function of the rear derailleur is to move the drive chain from one gear sprocket to another. The smaller sprockets on the gear cluster produce higher gear ratios. Pedaling in the higher gears requires greater pedaling effort, but takes you a greater distance with each revolution of the pedal cranks. The larger sprockets produce lower gear ratios. Using them requires less pedaling effort, but takes you a shorter distance with each pedal crank revolution. Moving the chain from a smaller sprocket of the gear cluster to a larger sprocket results in a downshift. Moving the chain from a larger sprocket to a smaller sprocket results in an upshift. In order for the derailleur to move the chain from one sprocket to another, the rider must be pedaling forward.

c. Shifting The Front Derailleur

The front derailleur, which is controlled by the left shifter, shifts the chain between the larger and smaller chainrings. Shifting the chain onto a smaller chainring makes pedaling easier (a downshift). Shifting to a larger chainring makes pedaling harder (an upshift).

d. Which Gear Should I Be In?

The combination of largest rear and smallest front gears is for the steepest hills; the smallest rear and largest front combination is for the greatest speed. It is not necessary to shift gears in sequence. Instead, find the “starting gear” which is right for your level of ability (a gear which is hard enough for quick acceleration but easy enough to let you start from a stop without wobbling) and experiment with upshifting and downshifting to get a feel for the different gear combinations. At first, practice shifting where there are no obstacles, hazards or other traffic, until you’ve built up your confidence. Learn to anticipate the need to shift, and shift to a lower gear before the hill gets too steep. If you have difficulties with shifting, the problem could be mechanical adjustment. **See your local bike mechanic for help.**

⚠ WARNING! NEVER SHIFT A DERAILLEUR TO THE LARGEST OR THE SMALLEST SPROCKET IF THE DERAILLEUR IS NOT SHIFTING SMOOTHLY. THE DERAILLEUR MAY BE OUT OF ADJUSTMENT AND THE CHAIN COULD JAM, CAUSING YOU TO LOSE CONTROL AND FALL.

⚠ WARNING! DO NOT FORCE THE SHIFT LEVERS. SHIFT ONLY WHEN PEDALING FORWARD AND WITHOUT STRONG FORCE. DO NOT BACKPEDAL. BACKPEDALING AND SHIFTING WHILE NOT PEDALING CAN DAMAGE THE SPROCKETS AND STRETCH THE CABLE WIRE.

e. What If It Won’t Shift Gears?

If moving the shift control one click repeatedly fails to result in a smooth shift to the next gear chances are that the mechanism is out of adjustment. Take the bike to your bike mechanic to have it adjusted.

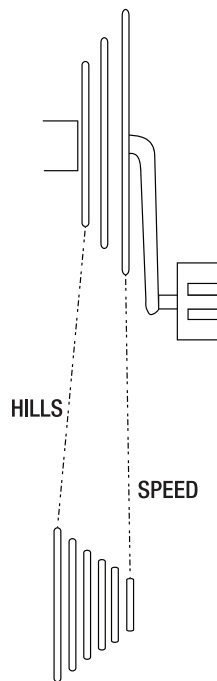

2. How An Internal Gear Hub Drivetrain Works

If your bicycle has an internal gear hub drivetrain, the gear changing mechanism will consist of:

- a 3, 5, 7, 8, 12 speed or possibly an infinitely variable internal gear position
- one, or sometimes two shifters
- one or two control cables~ one front sprocket called a chainring
- a drive chain

a. Shifting Internal Gear Hub Gears

Shifting with an internal gear hub drivetrain is simply a matter of moving the shifter to the indicated position for the desired gear. After you have moved the shifter to the gear position of your choice, ease the pressure on the pedals for an instant to allow the hub to complete the shift.

b. Which Gear Should I Be In?

The numerically lowest gear (1) is for the steepest hills. The numerically largest gear depending on the number of speeds of your hub, is for the greatest speed. Shifting from an easier, “slower” gear (like 1) to a harder, “faster” gear (like 2 or 3) is called an upshift. Shifting from a harder, “faster” gear to an easier, “slower” gear is called a downshift. It is not necessary to shift gears in sequence. Instead, find the “starting gear” for the conditions

At first, practice shifting where there are no obstacles, hazards or other traffic, until you’ve built up your confidence. Learn to anticipate the need to shift, and shift to a lower gear before the hill gets too steep. If you have difficulties with shifting, the problem could be mechanical adjustment. **See your local bike mechanic for help.**

c. What If It Won’t Shift Gears?

If moving the shift control one click repeatedly fails to result in a smooth shift to the next gear chances are that the mechanism is out of adjustment. **Take the bike to your local bike mechanic to have it adjusted.**

MAINTENANCE & REPAIR

Correct routine maintenance of your new bike will ensure a longer life for your bike and a safer ride for you.

Every time you ride your bike, its condition changes. The more you ride, the more frequently maintenance will be required. We recommend you spend a little time on regular maintenance tasks. The following schedules will assist you in knowing what tasks need to be performed and how often. **If you have any doubts about your abilities to accomplish these tasks, we recommend you take your bike to a professional bicycle mechanic periodically to have them done.**

Schedule 1 - Lubrication

Frequency	Component	Lubricant	How to Lubricate
Weekly	chain derailleur wheels derailleurs brake calipers brake levers	chain lube or light oil chain lube or light oil oil oil oil	brush on or squirt brush on or squirt oil can 3 drops from oil can 2 drops from oil can
Monthly	shift levers	lithium based grease	disassemble
Every Six Months	freewheel brake cables	oil lithium based grease	2 drops from oil can disassemble
Yearly	Bottom bracket pedals derailleur cables wheel bearings headset seat pillar	lithium based grease lithium based grease lithium based grease lithium based grease lithium based grease lithium based grease	Bicycle Mechanic disassemble disassemble Bicycle Mechanic Bicycle Mechanic disassemble

Note: The frequency of maintenance should increase with use in wet or dusty conditions. Do not over lubricate - remove excess lubricant to prevent dirt build up. Never use a degreaser to lubricate your chain (WD-40™)

Schedule 2 - Service Checklist

NOTE: Many instructions for adjustments can be found in the assembly portion of this manual.

Frequency	Task
Before every ride	<ul style="list-style-type: none"> Check wheel and pedal tightness Check tire pressure Check brake operation Check wheels for loose spokes, loose axle nuts or quick release Make sure all fasteners are tightened securely
After every ride	Quick wipe down with damp cloth
Weekly	Lubrication as per schedule 1
Monthly	<ul style="list-style-type: none"> Lubrication as per schedule 1 Check derailleur adjustment Check brake adjustment Check brake and gear cable adjustment Check tire wear and pressure Check wheels are true and spokes tight Check hub, head set and crank bearings for looseness Check pedals are tight Check handlebars are tight Check seat and seat post are tight and comfortably adjusted Check frame and fork for trueness Check all nuts and bolts are tight
Every six months	<ul style="list-style-type: none"> Lubrication as per schedule 1 Check all points as per monthly service Check and replace brake pads, if required Check chain for excess play or wear
Yearly	Lubrication as per schedule 1

TOOLS REQUIRED FOR MAINTENANCE

1. Open ended wrench or ring wrenches: 8mm, 9mm, 10mm, 12mm, 13mm, 14mm, 15mm
2. Open end or pedal wrench 15mm
3. Allen key wrenches: 4mm, 5mm, 6mm, 8mm
4. Adjustable wrench
5. Standard flat head screwdriver
6. Standard Phillips head screwdriver
7. Standard slip joint pliers
8. Tire pump
9. Tube repair kit
10. Tire levers

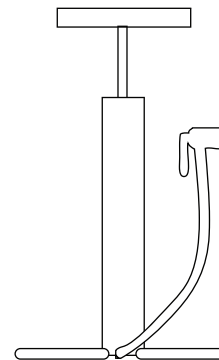

TRAVEL TOOLS

We suggest you take the following items with you when going on a long bike ride:

1. Spare tube
2. Patch kit
3. Pump
4. Tire levers
5. Multi-tool
6. Cell phone or change for a pay phone

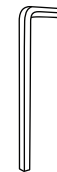

WHEELS AND TIRES

Wheel Inspection

It is most important that wheels are kept in top condition. Properly maintaining your bicycle's wheels will help braking performance and stability when riding. Be aware of the following potential problems:

- **Dirty or greasy rims:**

Caution: These can render your brakes ineffective. Do not clean them with oily or greasy materials. When cleaning, use a clean rag or wash with soapy water, rinse and air dry. Don't ride while they're wet. When lubricating your bicycle, don't get oil on the rim braking surfaces.

- **Wheels not straight:**

Lift each wheel off the ground and spin them to see if they are crooked or out of true. If wheels are not straight, they will need to be adjusted. This is quite difficult and is best left to a professional bicycle mechanic.

- **Broken or loose spokes:**

Check that all spokes are tight and that none are missing or damaged.

Caution: Such damage can result in severe instability and possibly an accident if not corrected. Again, spoke repairs are best handled by a mechanic.

- **Loose hub bearings:**

Lift each wheel off the ground and try to move the wheel from side to side. Caution: If there is movement between the axle and the hub, do not ride the bicycle. Adjustment is required.

- **Axle nuts:** Check that these are tight before each ride.

- **Quick release:** Check that these are set to the closed position and are securely tensioned before each ride.

WARNING!! If you are using a unit equipped with a quick release, always make sure the quick release lever is securely closed in a locked position. Also be certain your quick release lever is on the side opposite to the disc brake in your unit.

Caution: Maintain the closed position and the correct adjustment. Failure to do so may result in serious injury.

TIRE INSPECTION

Tires must be maintained properly to ensure road holding and stability. Check the following areas:

Inflation: Ensure tires are inflated to the pressure indicated on the sidewall of the tire. Improper inflation is the biggest cause of tire failure. Due to the slightly porous nature of bicycle inner tubes, it is normal for your tires to lose pressure over time. For this reason, it is critically important to maintain the proper tire inflation on your bike.

Caution: Use a hand or foot pump to inflate tires. NEVER inflate tires with an air compressor at a gas station. This can cause the tubes to over inflate and blowout.

Bead Seating: When inflating or refitting the tire, make sure that the bead is properly seated in the rim.

Tread: Check that the tread shows no signs of excessive wear or flat spots, and that there are no cuts or other damage.

Caution: Excessively worn or damaged tires should be replaced.

Valves: Make sure valve caps are fitted and that valves are free from dirt. A slow leak caused by the entry of the dirt can lead to a flat tire, and possibly a dangerous situation.

RECOMMENDED TIRE PRESSURES:

The recommended pressure molded on the sidewall of your bicycle tires should match the following chart. Use this as a general guide.

BMX	35-50 p.s.i.
MTB	40-65 p.s.i.
Road Touring	70-90 p.s.i.
Road Racing	110-125 p.s.i.
Hybrid/Crossbike	60-100 p.s.i.

HOW TO FIX A FLAT TIRE

If you need to repair a tire, follow these steps:

1. Remove the wheel from the bicycle.
2. Deflate the tire completely via the valve. Loosen the tire bead by pushing it inward all the way around.
3. Press one side of the tire bead up over the edge of the rim. Note: Use tire levers, not a screwdriver, otherwise you may damage the rim.
4. Remove the tube, leaving the tire on the rim.
5. Locate the leaks and patch using a tube repair kit or replace the tube. Note: Ensure that the replacement tube size matches the size stated on the tire sidewall and that the valve is the correct type for your bicycle.
6. Match the position of the leak in the tube with the tire to locate the possible cause and mark the location on the tire.
7. Remove the tire completely and inspect for a nail, glass, etc. and remove if located. Also inspect the inside of the rim to ensure there are no protruding spokes, rust or other potential causes. Replace the rim tape which covers the spoke ends.
8. Remount one side of the tire onto the rim.
9. **Using a hand pump**, inflate the tube just enough to give it some shape.
10. Place the valve stem through the hole in the rim and work the tube into the tire. Note: Do not let it twist.
11. Using your hands only, remount the other side of the tire by pushing the edge toward the center of the rim. Start on either side of the valve and work around the rim.
12. Before the tire is completely mounted, push the valve up into the rim to make sure the tire can sit squarely in position.
13. Fit the rest of the tire, rolling the last, most difficult part on using your thumbs. Note: Avoid using tire levers as these can easily puncture the tube or damage the tire.
14. Check that the tube is not caught between the rim and the tire bead at any point.
15. **Using a hand pump**, inflate the tube until the tire begins to take shape. Check that the tire bead is evenly seated all the way around the rim. When properly seated, fully inflate the tire to the pressure marked on the sidewall.
16. Replace the wheel into the frame checking that all gears, brakes and quick release levers are properly adjusted.

HUB BEARING ADJUSTMENT

When checked, the hub bearings of either wheel will require adjustment if there is any more than slight side play.

1. Check to make sure neither locknut is loose.
2. To adjust, remove wheel from bicycle and loosen the locknut on one side of the hub while holding the bearing cone on the same side with bicycle cone wrench or flat, thin open end wrench.
3. Rotate the adjusting cone as needed to eliminate free play.
4. Re-tighten the locknut while holding the adjusting cone in position.
5. Re-check that the wheel can turn freely without excessive side play.

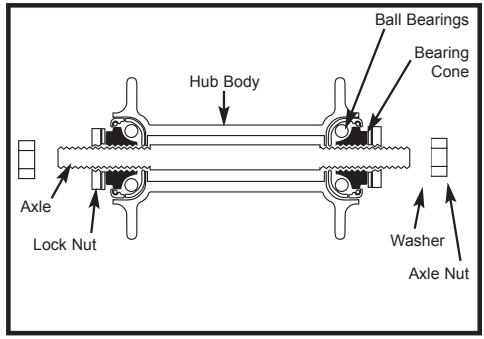

HEADSET

INSPECTION

The headset bearing adjustment should be checked every month. This is important as it is the headset which locks the fork into the frame, and if loose, can cause damage or result in an accident. While standing over the frame top tube with both feet on the ground, apply the front brake firmly and rock the bicycle back and forth; if you detect any looseness in the headset, it will need adjustment. Check that the headset is not over tight by slowly rotating the fork to the right and left. If the fork tends to stick or bind at any point, the bearings are too tight.

Note: If your bike is equipped with a threadless headset, please see a qualified specialist for repairs and adjustments.

ADJUSTMENT

Loosen the headset top locknut or remove it completely along with the reflector bracket, if fitted. Turn the adjusting cup clockwise until finger tight. Replace the lock washer or reflector bracket and tighten the lock nut using a suitable wrench.

Note: Do not over tighten or bearing damage will occur.

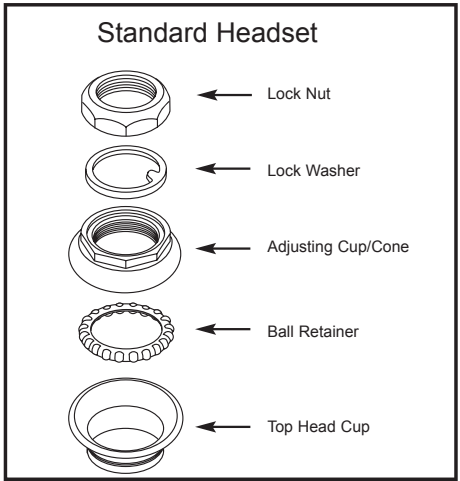

⚠ WARNING! ALWAYS MAKE SURE THAT THE HEADSET IS PROPERLY ADJUSTED AND THAT THE HEADSET LOCKNUT IS FULLY TIGHTENED BEFORE RIDING.

⚠ WARNING! OVER TIGHTENING THE STEM BOLT OR HEADSET ASSEMBLY MAY CAUSE DAMAGE TO THE BICYCLE AND/OR INJURY TO THE RIDER.

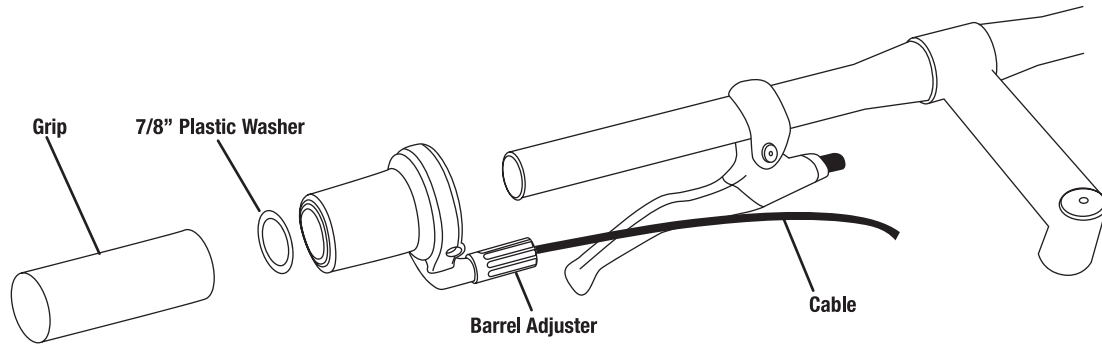

Grip Shift - Installation

1. Slide front Grip Shift assembly over left side of handlebar leaving proper clearance for handlebar grip. If necessary, move the brake lever to accommodate Grip Shift and handlebar grip.
2. Rotate assembly until cable exits beneath brake lever with adequate clearance for brake lever movement.
3. Firmly tighten recessed clamp screw. Installation torque should be 20 in.-lbs.
4. Slide the 7/8" plastic washer over handlebar. The washer prevents the grip from interfering with Grip Shift rotation.
5. Slide handlebar grip over handlebar. Thread the cable inner wire through cable housings and frame, and attach to derailleur. Make sure that the cable is in the V groove at the derailleur attachment bolt. If trimming the cable housing is necessary, be sure to replace the housing end cap.
6. Adjust indexing.
7. Slide rear Grip Shift over right side of handlebar and repeat steps 2 - 6.
8. Actuate front and rear brake levers to be certain of proper operation. If Grip Shift interferes with brake lever movement, rotate brake lever or Grip Shift. Check for proper brake lever operation again.

CABLES AND CABLE HOUSING

Cables and housing are one of the most overlooked parts on the bicycle. The first indication that your cables and housing need to be replaced is an increased amount of pressure needed to operate the brakes or shifters. Before every ride, check that there are no kinks or frays in the cables and housing. Check that the brake cables are correctly routed and not wrapped around the stem or frame in a manner that prevents smooth operation or hampers control of the bicycle. Also check that the housing is seated properly into each cable stop of the bicycle. It is recommended that the cables and housing are replaced at least every riding season to prolong the life of your bike.

⚠ WARNING! DO NOT RIDE A BICYCLE THAT IS NOT OPERATING PROPERLY.

⚠ WARNING! ALWAYS CHECK THE BRAKE CABLE ROUTING TO ENSURE SMOOTH AND FREE APPLICATION OF THE BRAKES. CABLES THAT ARE KINKED, FRAYED OR OTHERWISE DAMAGED, OR CABLES THAT ARE WRAPPED AROUND THE STEM OR FRAME MAY AFFECT BRAKING POWER OR CAUSE UNINTENDED SUDDEN STOPS AND LOSS OF CONTROL.

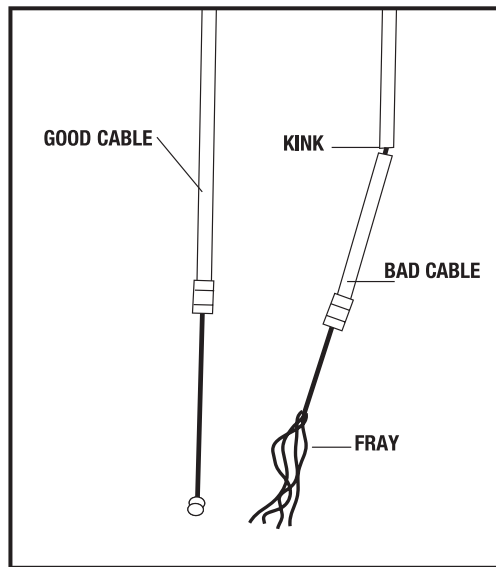

LUBRICATION

The brake lever and brake caliper pivot points should be oiled with 2-3 drops of light oil at least every three months to ensure smooth operation and to reduce wear. Cables should be greased along their entire length, after removing them from their casings, at least every six months. Always grease new cables before fitting.

ADJUSTMENT - SIDE-PULL CALIPERS

Minor brake adjustment can be made via the cable adjusting barrel, usually located at the upper cable arm.

Caution: The brake cable adjusting barrels are for minor adjustments only. For major adjustments see the appropriate section in the manual for the type of brakes on your bicycle.

To adjust, squeeze the brake pads against the rim, loosen the locknut and turn the adjuster. Brake pad clearance should be a maximum 2mm from the rim. When correct, retighten the lock nut. If the pads cannot be set close enough to the rim in this manner, you may have to adjust the cable length. Screw the barrel adjuster 3/4 of the way in, squeeze the pads against the rim, undo the cable anchor bolt and pull the cable through with pliers. Retighten the cable anchor bolt and apply full force to the brake lever to test, then fine tune using the barrel adjuster. If one pad is closer to the rim than the other, loosen the fixing nut at the back of the brake, apply the brake to hold it centered, and retighten the fixing nut.

⚠ WARNING! ENSURE THE BRAKE FIXING NUT IS SECURED TIGHTLY. FAILURE TO DO THIS MAY CAUSE THE BRAKE ASSEMBLY TO DISLodge FROM THE FORK/FRAmE.

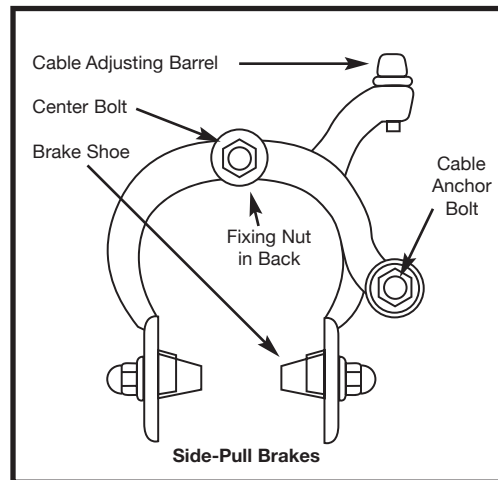
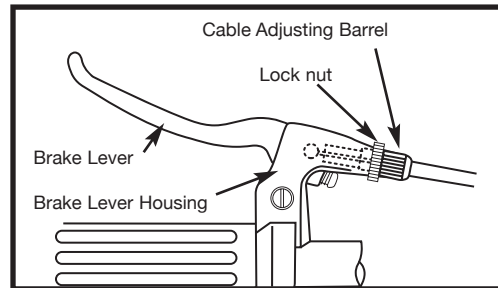

DERAILLEUR SYSTEMS

The derailleur system includes the front and rear derailleurs, the shift levers, and the derailleur control cables, all of which must function correctly for smooth gear shifting to occur. There are several different types of derailleur systems but all operate using similar principles. Your new bicycle may be fitted with a standard ‘friction’ type system where you will need to feel each gear shift into position. It may be fitted with an ‘index’ system (e.g. SIS) which links each different gear position to a positive click mechanism in the shifter, and makes shifting very simple and precise.

INSPECTION

The operation of the derailleur system should be checked at least every month. Check the operation of the rear derailleur first, then the front. The rear derailleur should shift the chain cleanly from one cog to the next without hesitation. On Index System equipped bicycles, each notched position in the shifter must equate to a new gear position. After shifting, the rear derailleur should not rub on the chain. The derailleur should never cause the chain to fall off the inner or outer freewheel cogs. The front derailleur should also shift the chain cleanly and without hesitation between each chainring. When the chain has been positioned onto a new chainring, it should not rub on the front derailleur. The chain should not fall off a chainring at anytime. Derailleur control cables are a critical component that must be well maintained for accurate shifting performance. Check them for any sign of rust, fraying, kinks, broken strands, and any damage to the cable housing. If you find any problems, the cables may need replacing before you ride.

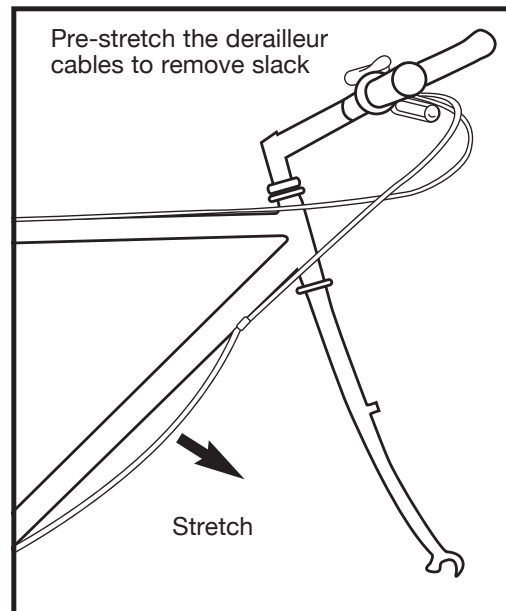

ADJUSTMENT - FRONT DERAILLEUR

1. Shift the rear shifter to the smallest number indicated, then shift the front shifter to the smallest number indicated. Disconnect the front derailleur cable from the cable anchor bolt and place the chain on the smallest chainwheel.
2. Make sure the front chainguide is parallel with the outer chainwheel on the crankset. There must be a 3-5mm gap between the bottom of the derailleur cage and the top of the outer chainwheel teeth to ensure the derailleur will clear the chainwheel when shifting.
3. Adjust the low limit screw so the chain is centered in the middle of derailleur cage. Pull all slack out of the cable by pulling it taut, then reconnect the cable and tighten the cable anchor bolt securely.
4. Shift the front shifter into the largest gear and pedal the bike so the chain jumps to the largest chainwheel. If the chain does not shift onto the largest chainwheel, you will need to turn the High limit screw counter-clockwise until the chain moves to the largest chainwheel. If the chain falls into the pedals, the High limit screw has been turned too far. You will need to readjust the High screw clockwise in 1/4 turn increments until the chain no longer falls off.
5. Shift through each gear ensuring all are achieved quietly and without hesitation.
6. Some shifters may have an adjusting barrel. Use the adjusting barrel to fine tune the adjustment of the chain location. Turn the adjusting barrel clockwise will move the derailleur outboard - away from the frame, while turning it clockwise will direct the chain inboard - towards the frame.

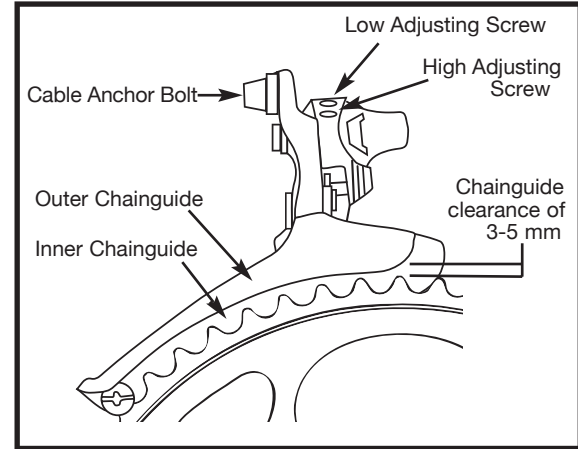

NOTE: It may take several adjustments to achieve the desired positioning.

LUBRICATION

All the pivoting points of the front and rear derailleurs should be lubricated with light oil at least every month. Be sure to wipe off any excess oil to prevent attraction of dirt into the mechanisms. The shifting cables should be cleaned and re-coated with a thin layer of grease every six months, or whenever new cables are being installed.

ADJUSTMENT - REAR DERAILLEUR

The Low limit screw determines how far the rear derailleur will travel toward the wheel of the bicycle, while the High limit screw determines how far the cage will travel toward the frame.

1. Shift the rear shifter to the largest number indicated, disconnect the rear derailleur cable from the cable anchor bolt and place the chain on the smallest sprocket.
2. Adjust the High limit screw so the chain and the smallest sprocket are lined up vertically. Remove any slack in the cable by pulling it taut, then re-connect the cable and tighten the cable anchor bolt securely.
3. Some derailleurs have an adjusting barrel (see drawing). Use the adjusting barrel to fine tune the adjustment of the chain location. Turning the adjusting barrel clockwise will move the derailleur outboard - away from the wheel - while turning it clockwise will direct the chain inboard - towards the wheel.
4. Shift the chain onto the largest sprocket; adjust the low limit screw so the chain and the largest cog are lined up vertically. If you are unable to get the chain to the largest cog, turning the Low limit screw counter-clockwise will enable the chain to move towards the wheel.
5. Shift through the gears ensuring each gear is achieved quietly and without hesitation.

NOTE: It may take several adjustments to achieve the desired positioning. Please refer to the troubleshooting section for more assistance.

NOTE: Some bicycles may be equipped with a rear derailleur mechanism that works in REVERSE to the directions above.

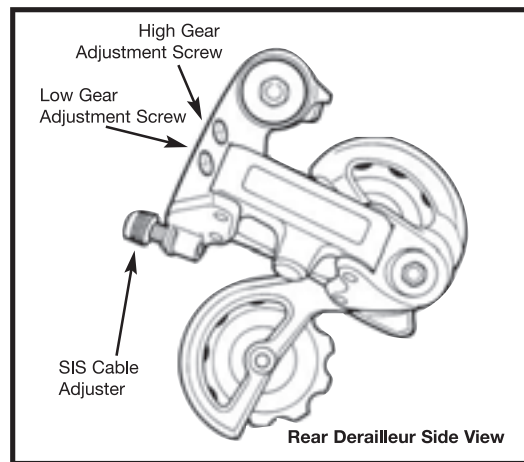
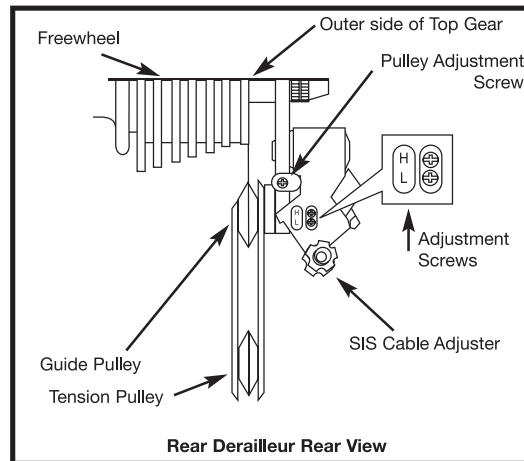

PEDALS

Pedals are available in a variety of shapes, sizes and materials, and each are designed with a particular purpose in mind. Some pedals can be fitted with toe clips and straps. These help to keep the feet correctly positioned and allow the rider to exert pulling force, as well as downward pressure, on the pedals. Use of toe clips with straps requires practice to acquire the necessary skill to operate them safely.

Inspection: Pedals should be inspected every month, taking note of the following areas:

- Check that the pedals are tightened securely against the crank arm. If pedals are allowed to become loose, they will not only be dangerous but will also cause irreparable damage to the cranks.
- Check that pedal bearings are properly adjusted. Move the pedals up and down, and right to left, and also rotate them by hand. If you detect any looseness or roughness in the pedal bearings then adjustment, lubrication or replacement is required.
- Ensure that the front and rear pedal reflectors are clean and securely fitted.

WARNING! Never ride with loose pedals. Always wear shoes.

Lubrication and Adjustment: Many pedals cannot be disassembled to allow access to the internal bearings and axle. However, it is usually possible to inject a little oil onto the inside bearings, and this should be done every six months. If the pedal is the type that can be fully disassembled, then the bearings should be removed, cleaned and greased every six to twelve months. Because of the wide variety of pedal types and their internal complexity, disassembly procedures are beyond the scope of this manual and further assistance should be sought from a professional bicycle mechanic.

Attachment

Note: The right and left pedals of a bicycle each have a different thread and are not interchangeable. Never force a pedal into the incorrect crank arm. Check for the right (R) and left (L) letters on each pedal and crank arm. Match the appropriate pedal to each crank (right to right and left to left) for assembly. Insert the correct pedal into the crank arm and begin to turn the thread with your fingers only. When the axle is screwed all the way in, securely tighten using a 15mm narrow open-ended wrench so that the shoulder of the pedal spindle is securely tightened against the crank arm. If removing a pedal, remember that the right pedal axle must be turned counter clockwise, i.e. the reverse of when fitting. If replacing the original pedals with a new set, make sure the size and the axle thread is compatible with the cranks on your bicycle. Bicycles use one of two types of cranks and these use different axle threads. Your bike may be equipped with cranks that are a one piece design with no separate axle. These operate with pedals that have a 1/2" (12.7mm) thread. Bikes equipped with three piece crank sets with a separate axle, left crank and right crank, use a slightly larger 9/16" (14mm) thread. Note: Never try and force a pedal with the wrong thread size into a bicycle crank.

CHAIN

Inspection: The chain must be kept clean, rust free and frequently lubricated in order to extend its life as long as possible. It will require replacement if it stretches, breaks, or causes inefficient gear shifting. Make sure that there are no stiff links, they must all move freely.

Lubrication

The chain should be lubricated with light oil at least every month, or after use in wet, muddy, or dusty conditions. Take care to wipe off excess oil, and not to get oil on the tires or rim braking surfaces.

Adjustment and Replacement

On derailleur geared bicycles the rear derailleur automatically tensions the chain. To adjust the chain on single speed freewheel, fixed gear, coaster hub braked or 3-speed hub geared bicycles:

1. Loosen the rear axle nuts (and coaster brake arm clip if fitted) and move the wheel forward to loosen, or backward to tighten, in the frame.
2. When correctly adjusted, the chain should have approximately 10mm of vertical movement when checked in the center between the chainwheel and rear sprocket. Center the wheel in the frame and re-tighten the axle nuts after any adjustment.

Chains require a special tool to fit and remove chain links, or to change the length. **We recommend that you go to a local bicycle mechanic to replace or change the length of your chain.**

FREEWHEEL

Inspection: Like the chain, the freewheel must be kept clean and well lubricated. If the chain has become worn and needs replacing, then it is likely that the freewheel will also have become worn and should also be replaced. Take the chain off the freewheel and rotate it with your hand. If you hear a grinding noise or the freewheel stops suddenly after spinning it, it may need adjustment or replacement. Such action is beyond the scope of this manual and you should consult a local bike mechanic.

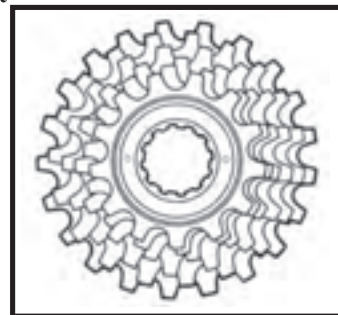
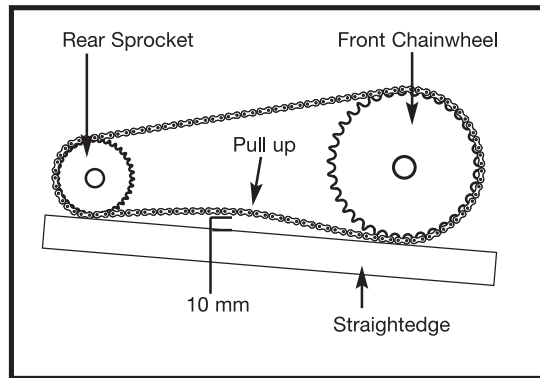

Problem	Possible Cause	Remedy
Gear shifts not working properly	<ul style="list-style-type: none"> - Derailleur cables sticking/stretched/damaged - Front or rear derailleur not adjusted properly - Indexed shifting not adjusted properly 	<ul style="list-style-type: none"> - Lubricate/tighten/replace cables - Adjust derailleurs - Adjust indexing
Slipping chain	<ul style="list-style-type: none"> - Excessively worn/chipped chainring or freewheel sprocket teeth - Chain worn/stretched-Stiff link in chain - Non compatible chain/chainring/freewheel 	<ul style="list-style-type: none"> - Replace chainring, sprockets and chain - Replace chain - Lubricate or replace link - Seek advice at a bicycle shop
Chain jumping off freewheel sprocket or chainring	<ul style="list-style-type: none"> - Chainring out of true - Chainring loose - Chainring teeth bent or broken -Rear or front derailleur side-to-side travel out of adjustment 	<ul style="list-style-type: none"> - Re-true if possible, or replace - Tighten mounting bolts - Repair or replace chainring/set - Adjust derailleur travel
Constant clicking noises when pedaling	<ul style="list-style-type: none"> - Stiff chain link - Loose pedal axle/bearings - Loose bottom bracket axle/bearings - Bent bottom bracket or pedal axle - Loose crankset 	<ul style="list-style-type: none"> - Lubricate chain / Adjust chain link - Adjust bearings/axle nut - Adjust bottom bracket - Replace bottom bracket axle or pedals - Tighten crank bolts
Grinding noise when pedaling	<ul style="list-style-type: none"> - Pedal bearings too tight - Bottom bracket bearings too tight - Chain fouling derailleurs - Derailleur jockey wheels dirty/binding 	<ul style="list-style-type: none"> - Adjust bearings - Adjust bearings - Adjust chain line - Clean and lubricate jockey wheels

Problem	Possible Cause	Remedy
Freewheel does not rotate	- Freewheel internal pawl pins are jammed	- Lubricate. If problem persists,replace freewheel
Brakes not working effectively	- Brake blocks worn down - Brake blocks/rim greasy, wet or dirty - Brake cables are binding/stretched/damaged - Brake levers are binding - Brakes out of adjustment	- Replace brake blocks - Clean blocks and rim - Clean/adjust/replace cables - Adjust brake levers - Center brakes
When applying the brakes they squeal/squeak	- Brake blocks worn down - Brake block toe-in incorrect - Brake blocks/rim dirty or wet - Brake arms loose	- Replace blocks - Correct block toe-in - Clean blocks and rim - Tighten mounting bolts
Knocking or shuddering when applying brakes	- Bulge in the rim or rim out of true - Brake mounting bolts loose - Brakes out of adjustment - Fork loose in head tube	- True wheel or take to a bike shop for repair - Tighten bolts - Center brakes and/or adjust brakeblock toe-in - Tighten headset
Wobbling wheel	- Axle broken - Wheel out of true - Hub comes loose - Headset binding - Hub bearings collapsed - QR mechanism loose	- Replace axle - True wheel - Adjust hub bearings - Adjust headset - Replace bearings - Adjust QR mechanism

Problem	Possible Cause	Remedy
Steering not accurate	<ul style="list-style-type: none">- Wheels not aligned in frame- Headset loose or binding- Front forks or frame bent- Stem wedge bolt not tight	<ul style="list-style-type: none">- Align wheels correctly- Adjust/tighten headset- Take bike to a bike shop for possible frame realignment- Tighten stem bolt
Frequent punctures	<ul style="list-style-type: none">- Inner tube old or faulty- Tire tread/casing worn- Tire unsuited to rim- Tire not checked after previous puncture- Tire pressure too low- Spoke protruding into rim	<ul style="list-style-type: none">- Replace Inner tube- Replace tire- Replace with correct tire- Remove sharp object embedded in tire- Correct tire pressure- File down spoke

LIMITED WARRANTY

This Limited Warranty extends only to the original retail purchaser, who must produce proof of purchase in order to validate any claim. This warranty is not transferable to anyone else.

What does this Limited Warranty cover? This warranty covers all parts of the bicycle to be free of defects in workmanship and materials.

What must you do to keep the Limited Warranty in effect? This warranty is effective only if:

- The bicycle is completely and correctly assembled.
- The bicycle is used under normal conditions for its intended purpose, by a person that properly fits and is capable of controlling the bicycle.
- The bicycle receives all necessary maintenance and adjustments.

What is not covered by this Limited Warranty? This warranty does not include labour and transportation charges. The bicycle is designed for general transportation and recreational use only. This warranty does not cover normal wear and tear, paint, rust, normal maintenance items, personal injury, or any damage, failure, or loss that is caused by accident, improper assembly, maintenance, adjustment, storage, or use of the bicycle.

This Limited Warranty will be void if the bicycle is ever:

- Used in any competitive sport.
- Used for stunt riding, jumping, aerobatics or similar activity.
- Installed with a motor or modified in any other way.
- Ridden by more than one person at a time.
- Rented or used for commercial purposes.
- Used in a manner contrary to the instructions in this Owner's Manual. Kent International will not be liable for incidental or consequential loss or damage, due directly or indirectly from use of this product.

For how long does this Limited Warranty last? The frame is warranted for the usable life of the bicycle. Kent International will replace the frame at no charge, should it fail in any weld point when the cycle has been used in a normal manner, and determined by our inspection. Kent will also replace the bicycle fork if it should fail at any weld point. You must receive prior authorization from Kent Customer Service, before returning any product or parts. All other components are warranted against defects for six months from the date of purchase when properly assembled and used in a normal manner.

What will Kent do? We will replace, without charge to you, any frame, fork, or component found to be defective by Kent. **CONSUMER MUST PAY ALL LABOR AND TRANSPORTATION CHARGES CONNECTED WITH THE REPAIR OR WARRANTY WORK.**

How do you get service? Phone the Customer Service Department (8am - 4pm E.S.T.) at 1-800-451-KENT. All warranty claims should be made to Kent International, Inc. 60 E. Halsey Rd. Parsippany, NJ 07054 USA.

What rights do you have? This limited warranty gives you specific legal rights. You may also have other rights which vary from State to State.