

Assembly Instructions
Instrucciones De Ensamblaje
Instructions D'Assemblage



LIMITED 90 DAYS WARRANTY

This product is covered by a limited warranty that is effective for 90 days from the date of purchase. If, during the limited warranty period, a part is found to be defective or breaks, we will offer replacement parts at no cost to you, the customer. The only exceptions to the warranty include mainframes, table tops, playing surfaces, batteries or tools.

The above warranty will not apply in cases of damages due to improper usage, alteration, misuse, abuse, accidental damage or neglect.

This Limited Warranty gives you specific legal rights and you may also have other rights vary from one State (province) to another.

A PURCHASE RECEIPT (or other proof of purchase) will be required before any warranty service is initiated. For all requests for warranty service, please feel free to contact our Consumer Service Department.

Please be aware of your product's Limited Warranty for the return/refund policy from the store. We, at Medal Sports, cannot handle the product which is out of product's limited warranty since we only provide available parts. Thank you!

PLEASE CONTACT US BEFORE RETURNING THE PRODUCT TO THE STORE!

GARANTÍA LIMITADA DE 90 DÍAS

Este producto está cubierto por una garantía limitada que tiene una vigencia de 90 días a partir de la fecha de su compra. Durante el período de la garantía limitada, si una parte defectuosa o quebrada es encontrada, nosotros ofreceremos una reparación o un reemplazo de la partes sin ningún costo para usted, nuestro cliente. Las únicas excepciones de la garantía incluyen unidades centrales, tableros de mesa, superficies de juego, pilas o herramientas.

La susodicha garantía no se aplicará en los casos de daños debido al uso impropio, la alteración, el mal uso, el abuso, el daño accidental o la negligencia.

Esta garantía limitada le da a usted derechos legales específicos, usted también puede tener otros derechos que varían de un estado (provincia) a otro.

EL RECIBO DE LA COMPRA (U otra prueba de compra) sería requerida antes que cualquier servicio de garantía fuera iniciada. Para todo pedido por servicio de garantía, por favor siéntase libre de ponerse en contacto con nuestro Departamento de Servicio de Consumidor.

Por favor tenga en cuenta sobre la Garantía Limitada de su producto para la política de vuelta/reembolso desde la tienda. Nosotros, Medal Sports, no podemos manejar el producto que está fuera del límite de garantía ya que proporcionamos solamente partes disponibles. ¡Gracias!

¡POR FAVOR PÓNGASE EN CONTACTO CON NOSOTROS ANTES DE DEVOLVER EL PRODUCTO A LA TIENDA!

GARANTIE LIMITEE DE 90 JOURS

Ce produit est couvert par une garantie limitée valable 90 jours à compter de la date d'achat. Si pendant cette période une pièce est jugée défectueuse ou se casse, nous la remplacerons gratuitement. Les seules exceptions à la garantie comprennent les armatures principales, les dessus de table, les surfaces de jeu, les piles ou les outils.

La garantie ci-dessus ne s'applique pas en cas de dommages occasionnés par une mauvaise utilisation, une altération, un abus, des un dommage accidentel ou une négligence.

Cette garantie limitée vous accorde des droits légaux spécifiques ainsi que d'autres droits variant d'un état (province) à un autre.

UNE FACTURE D'ACHAT (ou toute autre preuve d'achat) sera exigée avant toute intervention sous garantie. Pour toute demande d'intervention sous garantie, veuillez contacter notre Service Clientèle.

Comprenez votre garantie limitée de produit en ce qui concerne notre politique de retour/remboursement depuis le magasin. Chez Medal Sports, nous ne pouvons pas traiter un produit qui n'est plus sous garantie puisque nous ne pouvons que fournir les pièces disponibles. Remerciements!

VEUILLEZ NOUS CONTACTER AVANT DE RETOURNER LE PRODUIT AU MAGASIN!



WE ARE READY TO HELP

DO NOT RETURN TO STORE

ESTAMOS LISTOS AYUDA

NO DEVOLVERLO A LA TIENDA

NOUS SOMMES PRÊTS À VOUS AIDER

NE PAS RAPPORTER EN MAGASIN

Please Contact | Por favor Contactar | Veuillez contacter

MD SPORTS

Customer Service
Toll Free

Servicio al Cliente
Llamada Gratuita

Service Clientèle
Appel Gratuit

877-472-4296

Mon.-Fri.,
9:00 a.m. to 5:00 p.m. EST

Lunes a Viernes,
9:00 a.m. a 5:00 p.m. ET

Du lundi au vendredi de
9:00 a 17 heures HNE

For additional resources and
Frequently Asked Questions,
please visit us at

Por mayor información y
Preguntas Frecuentes, favor
visitarnos en

Pour toute information
complémentaire ou réponse
aux questions fréquentes,
veuillez vous rendre sur

www.medalsports.com

TOOLS REQUIRED

Phillips Screwdriver - **Not Included**
Standard (Flat Head - **Not Included**
Screwdriver)
Allen Key - **Included**

HERRAMIENTAS NECESARIAS

Destornillador Phillips - **No incluido**
Destornillador de
Cabeza Plana - **No incluido**
Llave Allen - **Incluido**

OUTILS REQUIS

Tournevis cruciforme - **Non inclus**
Tournevis standard - **Non inclus**
(Tête plate)
Clé hexagonale - **Incluse**

 **RECOMMENDED**

Electric Screwdrivers may be helpful during assembly; however, please set a low torque and use extreme caution.

 **RECOMENDADO**

Los destornilladores eléctricos pueden ser de gran ayuda durante el ensamblado; sin embargo, por favor ajuste el par de giro bajo y sea extremadamente precavido.

RECOMMANDÉ 

Un tournevis électrique peut être utile pour l'assemblage; utilisez cependant une vitesse de rotation lente et avec prudence.



Power Tools: **Set to Low Torque**
/Herramientas eléctricas: **Establecer bajo par de torsión**
/Visseuse électrique: **Couple faible**



High Torque Over Tightened
/ Alto par más estrictas
/ Un couple élevé peut créer des dommages

! IMPORTANT NOTICE

1. This product is intended for INDOOR use only.
2. Please do not sit, climb or lean on the product.
3. Please do not drag the product when moving it in order to avoid damaging the legs.
4. Please only use furniture polish spray to clean the exterior surfaces of the product.
5. Adult supervision is required for children playing this game.

AVISO IMPORTANTE

1. Este producto está destinado para el uso INTERIOR solamente.
2. Por favor no sientes, subas o inclines el producto.
3. Por favor no arrastres el producto cuando está moviendo para evitar el daño sobre las piernas.
4. Por favor use solamente spray de pulido para muebles para limpiar la superficie exterior del producto.
5. Se requieren la supervisión adulta para niños cuando esté jugando al juego.

NOTE IMPORTANTE !

1. Ce produit est conçu pour une utilisation en intérieur uniquement.
2. Veuillez ne pas vous asseoir, grimper ou vous appuyer sur la produit.
3. Veuillez ne pas déplacer la produit en la tirant pour ne pas endommager les pieds.
4. Veuillez utiliser seulement le vernis pour meuble pour nettoyer les surfaces extérieures du produit de jeu.
5. La surveillance d'adultes est requise pour les enfants qui jouent ce jeu.



At least 2 adults needed
Se necesitan al menos 2 adultos
Il faut au moins 2 adultes



No children in assembly area
No deben estar los niños en el area de ensamble
Pas d'enfants dans la zone d'assemblage



Keep away from pets in assembly area
Mantener alejados a los animales domesticos del area de ensamble
Tenir les animaux de compagnie à distance



Do not use or keep product outdoors. For indoor use only. No wet/humid conditions.
No usar o guardar el producto en el exterior. Solo para uso en interior. No utilizar ni guardar el producto en lugares húmedos o mojados
N'utilisez ni ne stockez ce produit en extérieur. Uniquement pour utilisation en intérieur. Ne pas exposer à l'humidité

! WARNING

Adult assembly required.
CHOKING HAZARD - This item contains small parts and small balls. Not suitable for children under 3 years.

! ADVERTENCIA

El ensamblaje debe ser realizado por un adulto.
PELIGRO DE ASFIXIA - Este artículo contiene piezas pequeñas y pequeñas bolas. No es apto para niños menores de 3 años de edad.







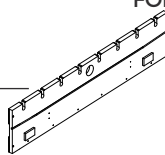
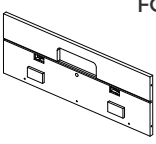
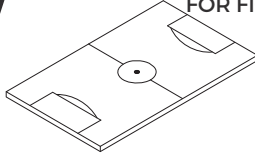
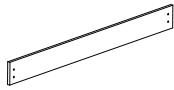
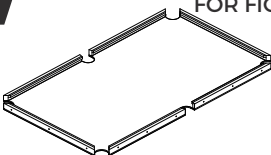
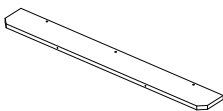

! ATTENTION

L'assemblage doit être effectué par des adultes.
RISQUE D'ÉTOUFFEMENT - Cet article contient de petites pièces et de petites boules. Ne convient pas aux enfants de moins de 3 ans.

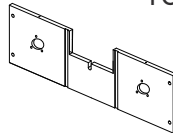
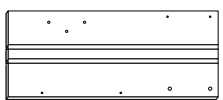
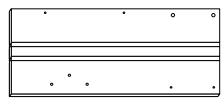
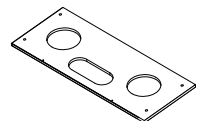
PARTS IDENTIFIER

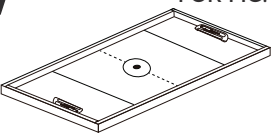
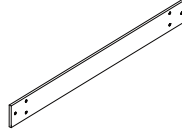
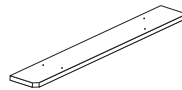
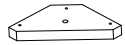
IDENTIFICADOR DE PIEZAS

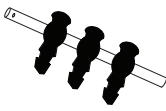
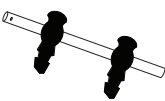
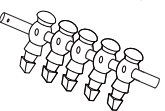
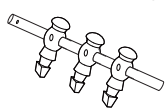
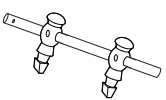
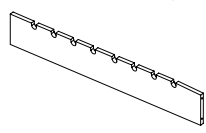

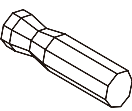
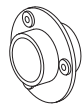

IDENTIFICATEUR DE PIÈCES

PART NUMBER NÚMERO DE PIEZA NUMÉRO D'ARTICLE			 1 FOR FIG. 1, 3			FIG. NUMBER NÚMERO DE FIG. NUMÉRO FIG.					
PART PIEZA PIÈCE			x2			QUANTITY CANTIDAD QUANTITÉ					
PART NAME			Side Apron	Delantal lateral	Tablier latéral	NOM DE LA PIÈCE NOMBRE DE PIEZA					
2 FOR FIG. 1			3 FOR FIG. 2			4 FOR FIG. 4			5 FOR FIG. 7		
 x2			 x1			 x2			 x1		
End Apron	Delantal final	Tablier final	Soccer Playfield	Campo de juego de fútbol	Terrain de jeu football	Support Brace-A	Abrazadera de soporte-A	Barre de support-A	Billiard Playfield	Campo de juego de billar	Terrain de jeu de billard
6 FOR FIG. 12			7 FOR FIG. 11			8 FOR FIG. 11			9 FOR FIG. 11		
 x2			 x4			 x2			 x2		
Under Leg Pedestal	Bajo pierna pedestal	Partie inférieure de la jambe du piédestal	Support Brace-B	Abrazadera de soporte-B	Barre de support-B	Top Slat Board	Tabla de tira superior	Planche à lattes supérieure	End Panel-A	Panele de punta-A	Panneau d'extrémité-A
10 FOR FIG. 13			11 FOR FIG. 13			12 FOR FIG. 14			13 FOR FIG. 16		
 x2			 x2			 x2			 x2		
Right Leg	Pata derecha	Pied droit	Left Leg	Pata izquierda	Pied gauche	End Panel-B	Panele de punta-B	Panneau d'extrémité-B	End Leg Panel	Panel de extremo para pata	Panneau inférieur du pied
14 FOR FIG. 27			15 FOR FIG. 17			16 FOR FIG. 21			17 FOR FIG. 13		
 x1			 x2			 x2			 x4		
Table Tennis and Hockey Top	Tenis de mesa y cima de hockey	Tennis de table et partie supérieure hockey	Side Leg Panel	Panel lateral para pata	Panneau latéral de pied	Top Rail	Riel superior	Glissière supérieure	Leg Base	Bases de pata	Base Pied
18 FOR FIG. 4			19 FOR FIG. 22			20 FOR FIG. 22			21 FOR FIG. 22		
 x4			 x1			 x2			 x1		
"L" Bracket	Corchete "L"	Patte de Fixation en "L"	5-Player Rod - Black	Barra de 5 jugadores - Negro	Tige à 5 Joueurs - Noir	3-Player Rod - Black	Barra de 3 jugadores - Negro	Tige à 3 Joueurs - Noir	2-Player Rod - Black	Barra de 2 jugadores - Negro	Tige à 2 Joueurs - Noir
22 FOR FIG. 22			23 FOR FIG. 22			24 FOR FIG. 22			25 FOR FIG. 18		
 x1			 x2			 x1			 x2		
5-Player Rod - Silver	Barra de 5 jugadores - Plateado	Tige à 5 Joueurs - Argent	3-Player Rod - Silver	Barra de 3 jugadores - Plateado	Tige à 3 Joueurs - Argent	2-Player Rod - Silver	Barra de 2 jugadores - Plateado	Tige à 2 Joueurs - Argent	Support Brace-C	Abrazadera de soporte-C	Barre de support-C
26 FOR FIG. 28			27 FOR FIG. 22			28 FOR FIG. 22			29 FOR FIG. 11		
 x1			 x8			 x8			 x4		
Score Board	Tablero de puntuación	Tableau de bord	Rod End Cap	Corra de barra final	Capuchon de bout de tige	Handle	Manija	Poignée	Knob Receiver	Receptor de perilla	Récepteur de bouton

PARTS IDENTIFIER

IDENTIFICADOR DE PIEZAS









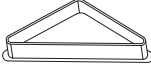

IDENTIFICATEUR DE PIÈCES

30 FOR FIG. 20  x4			31 FOR FIG. 10  x4			32 FOR FIG. 16  x4			33 FOR FIG. 13  x1		
Locking knob	Perilla de cerradura	Bouton de verrouillage	Plastic Strip	Tira plástica	Bande en plastique	Leg Leveler	Nivelador de pata	Niveleur de pied	Glue	Pegamento	Colle
34 FOR FIG. 24  x2			35 FOR FIG. 21  x2			36 FOR FIG. 17  x2			37 FOR FIG. 17  x2		
Slide Scorer	Marcador deslizante	Marqueur à main	Ball Entry Rim	Aro de Entrada para Pelota	Ouverture d'entrée du ballon	Side Leg Brace-A	Abrazadera de pierna later-A	Entretoise de jambe latérale-A	Side Leg Brace-B	Abrazadera de pierna later-B	Entretoise de jambe latérale-B
38 FOR FIG. 6  x2			39 FOR FIG. 6  x4			40 FOR FIG. 9  x2			41 FOR FIG. 9  x4		
Side Pocket	Tronera lateral	Poche latérale	Corner Pocket	Tronera de la esquina	Poche de coin	Side Pocket Cap	Canasta lateral	Capuchon poche latérale	Corner Pocket Cap	Canasta de la esquina	Capuchon poche de coin
42 FOR FIG. 28  x1			43 FOR FIG. 28  x2			44 FOR FIG. 22  x16			45 FOR FIG. 23  x16		
Table Tennis Net	Red de tenis de mesa	Filet de tennis de table	Table Tennis Post	Poste de mesa de tenis	Poteau pour tennis de table	Rod Clip-A	Clip de biela-A	Clip de tige -A	Rod Clip-B	Clip de biela -B	Clip de tige -B
46 FOR FIG. 22  x16			47 FOR FIG. 22  x16			48 FOR FIG. 10  x2			49 FOR FIG. 26  x2		
Rod Washer	Arandela de barra	Rondelle de tige	Rod Bumper	Amortiguador de barra	Tampon de tige	M21x58mm Bolt	Perno M21x58mm	Boulon M21x58mm	Hook	Gancho	Crochet

ACCESSORIES

ACCESORIOS

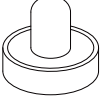









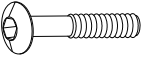
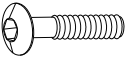

ACCESSOIRES

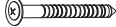
50 FOR FIG. 26  x1			51 FOR FIG. 26  x1			52 FOR FIG. 26  x1			53 FOR FIG. 26  x2		
Billiard Ball Set	Bola de billar	Ensemble boules de billard	Brush	Cepillo	Brosse	Triangle	Triángulo	Triangle	Cue	Taco	Queue de billard
54 FOR FIG. 26  x2			55 FOR FIG. 24  x2			56 FOR FIG. 28  x2			57 FOR FIG. 28  x2		
Chalk	Tiza	Craie	Soccer Ball	Pelota de fútbol	Ballon de soccer	Table Tennis Ball	Bola de tenis de mesa	Balle de ping-pong	Table Tennis Paddle	Paleta de tenis de mesa	Raquette de tennis de table
58 FOR FIG. 27  x2			59 FOR FIG. 27  x2			60 FOR FIG. 27  x2					
Pusher	Mazo	Poussoir	Felt Pad	Almohadilla de fieltro	Coussinet de feutre	Puck	Disco	Palet			

HARDWARE

HARDWARE

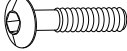

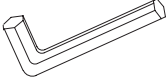





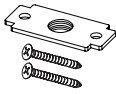

MÉTAUX

A1 FOR FIG. 18  x12			A2 FOR FIG. 17  x12			A3 FOR FIG. 14, 17, 18  x32			A4 FOR FIG. 14, 17, 18  x32		
M6x28mm Bolt	Perno M6x28mm	Boulon M6x28mm	M6x22mm Bolt	Perno M6x22mm	Boulon M6x22mm	M6 Washer	Arandela M6	Rondelle M6	M6 Spring Lock Washer	Arandela de cierre de resorte M6	Rondelle de blocage M6
A5 FOR FIG. 9, 21  x14			A6 FOR FIG. 1, 3  x8			A7 FOR FIG. 21  x8			A8 FOR FIG. 8, 11, 12, 13, 15, 16, 18  x62		
3.5x12mm Flat Head Screw	Tornillo de Cabeza Plana 3.5x12mm	Vis à Tête Plate 3.5x12mm	4x45mm Screw	Tornillo 4x45mm	Vis 4x45mm	4x40mm Screw	Tornillo 4x40mm	Vis 4x40mm	3.5x35mm Screw	Tornillo 3.5x35mm	Vis 3.5x35mm
A9 FOR FIG. 7  x6			A10 FOR FIG. 24  x4			A11 FOR FIG. 10  x8			A12 FOR FIG. 14  x8		
3.5x28mm Screw	Tornillo 3.5x28mm	Vis 3.5x28mm	3.5x25mm Screw	Tornillo 3.5x25mm	Vis 3.5x25mm	3x14mm Screw	Tornillo 3x14mm	Vis 3x14mm	M6x20mm Bolt	Perno M6x20mm	Boulon M6x20mm
A13 FOR FIG. 4, 5, 6, 11, 16  x48			A14  x1								
3.5x12mm Screw	Tornillo 3.5x12mm	Vis 3.5x12mm	Allen key	Llave allen	Clé hexagon						

PRE-INSTALLED PARTS

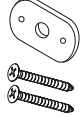
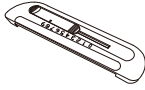
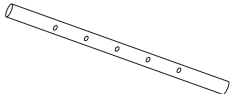
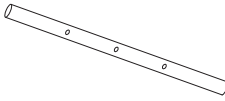
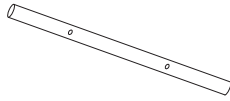
PIEZAS PREINSTALADAS

PIÈCES PRÉINSTALLÉES

P1 FOR FIG. 1			P2 FOR FIG. 13			P3 FOR FIG. 13, 17			P4 FOR FIG. 11		
											
x4			x4			x20			x4		
Locking Seat	Asiento de bloqueo	Siège de verrouillage	M8 Square Nut with Screws	M8 Tuerca cuadrada con tornillos	Écrou carré avec vis M8	M6 Nut	Tuerca M6	Écrou M6	Barrel Nut	Tuerca de barril	Écrou à manchon
P5 FOR FIG. 14			P6 FOR FIG. 14			P7 FOR FIG. 17			P8 FOR FIG. 1		
											
x2			x4			x12			x2		
Ball Return Cover	Cubierta de Retorno de Bola	Couvercle Retour de Balle	Plastic Cover	Casquette en plastique	Tapa de plástico	M6 T - Nut	Tuerca - T M6	T - Écrou M6	M21 Square Nut with Screws	M21 Tuerca cuadrada con tornillos	Écrou carré avec vis M21
P9 FOR FIG. 27			P10 FOR FIG. 22			P11 FOR FIG. 22			P12 FOR FIG. 22		
											
x2			x2			x4			x2		
Hockey Goal	Portería de hockey	But de hockey	5-Hole Rod	Barra con 5 Orificios	Tige à 5 trous	3-Hole Rod	Barra con 3 Orificios	Tige à 3 trous	2-Hole Rod	Barra con 2 Orificios	Tige à 2 trous
P13 FOR FIG. 22			P14 FOR FIG. 22			P15 FOR FIG. 22			P16 FOR FIG. 22		
											
x13			x13			x26			x26		
Player - Black	Jugador - Negro	Joueur - Noir	Player - Silver	Jugador - Plateado	Joueur - Argent	T4x28mm Bolt	Perno T4x28mm	Boulon T4x28mm	M4 Nut	Tuerca M4	Écrou M4

BEFORE ASSEMBLY

1. Find a clean, level place to begin the assembly of your product.
2. Verify that you have all listed parts as shown on the part list pages. If any parts are missing, call our customer service.

ANTES DE MONTAR

1. Encuentre un lugar limpio y nivelado para comenzar el ensamblaje del producto.
2. Compruebe que tenga todas las piezas que se muestran en la lista de piezas. Si falta alguna pieza, llame a nuestro servicio al cliente.

AVANT L'ASSEMBLAGE

1. Trouvez un endroit propre et plat pour commencer à assembler votre produit.
2. Vérifiez que vous avez toutes les pièces énumérées comme indiqué sur les pages de liste des pièces. S'il y a des pièces qui manquent, appelez notre service clientèle.

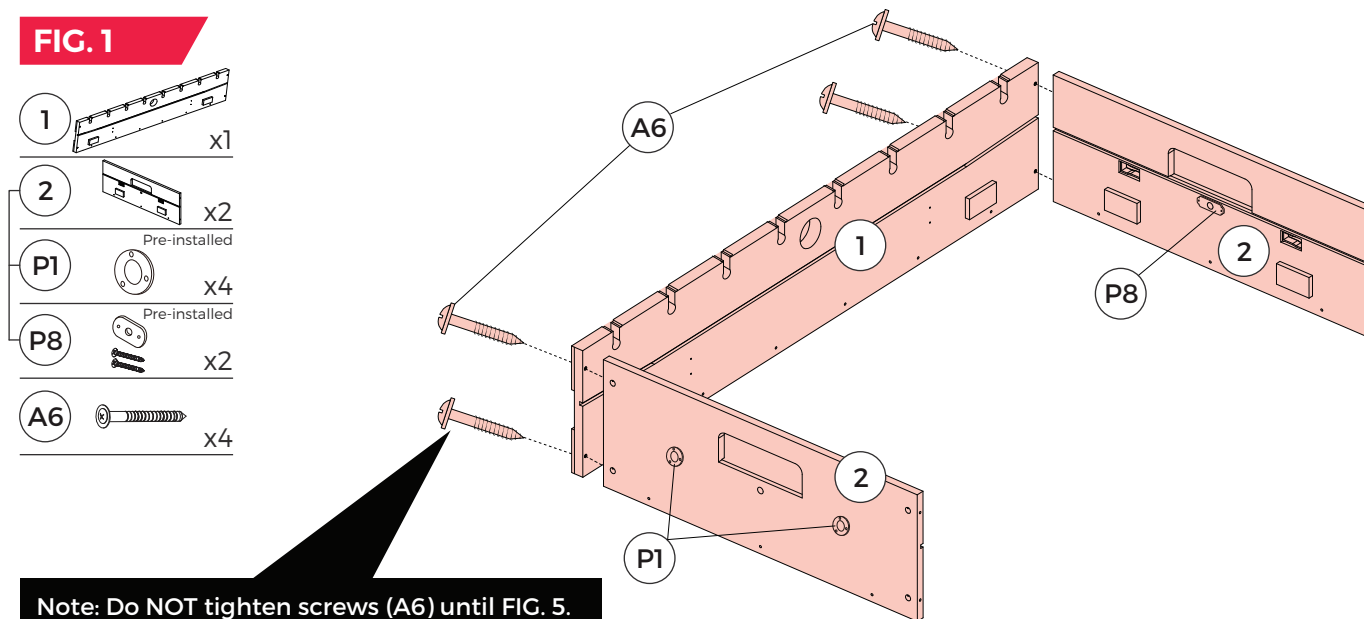
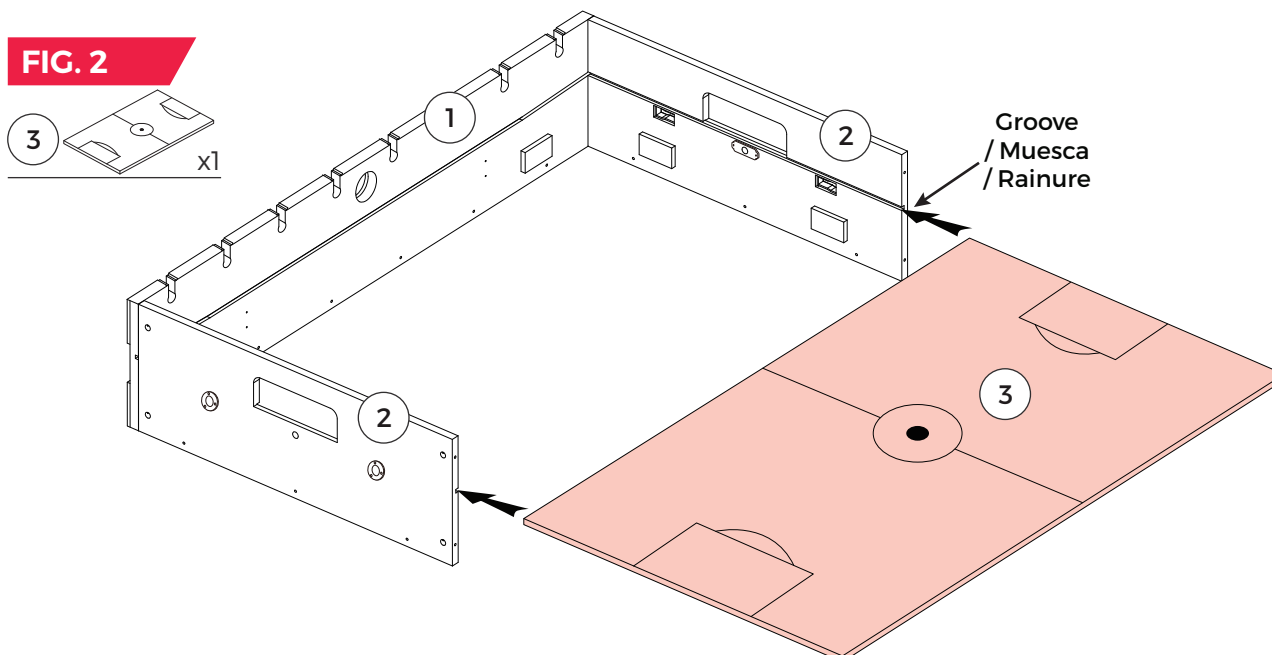
ASSEMBLY**MONTAJE****ASSEMBLAGE****FIG. 1****FIG. 2**

ASSEMBLY

MONTAJE

ASSEMBLAGE

FIG. 3

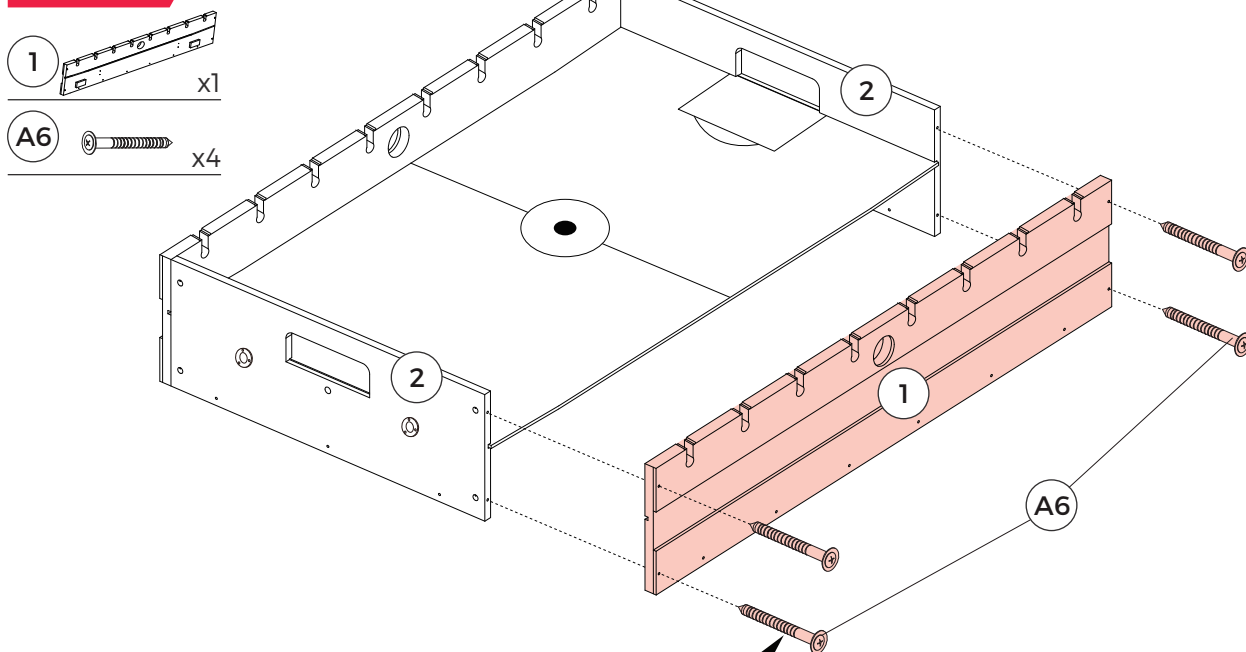

Note: Do NOT tighten screws (A6) until FIG. 5.

Nota: NO el pestillo tornillo (A6) hasta FIG. 5.

Note: NE PAS serrer les vis à fond (A6) avant l'étape de la FIG. 5.

FIG. 4

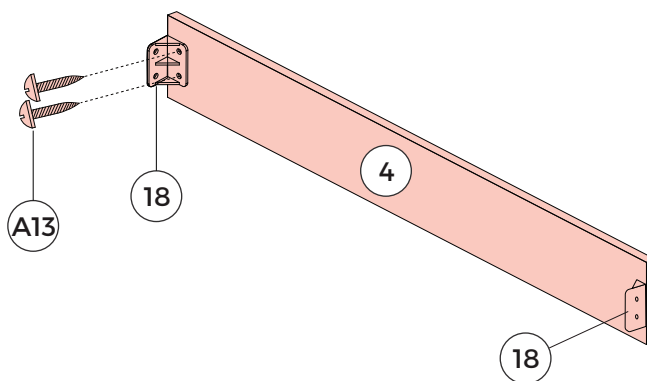
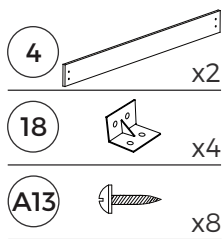

ASSEMBLY

MONTAJE

ASSEMBLAGE

FIG. 5

- A13  x8

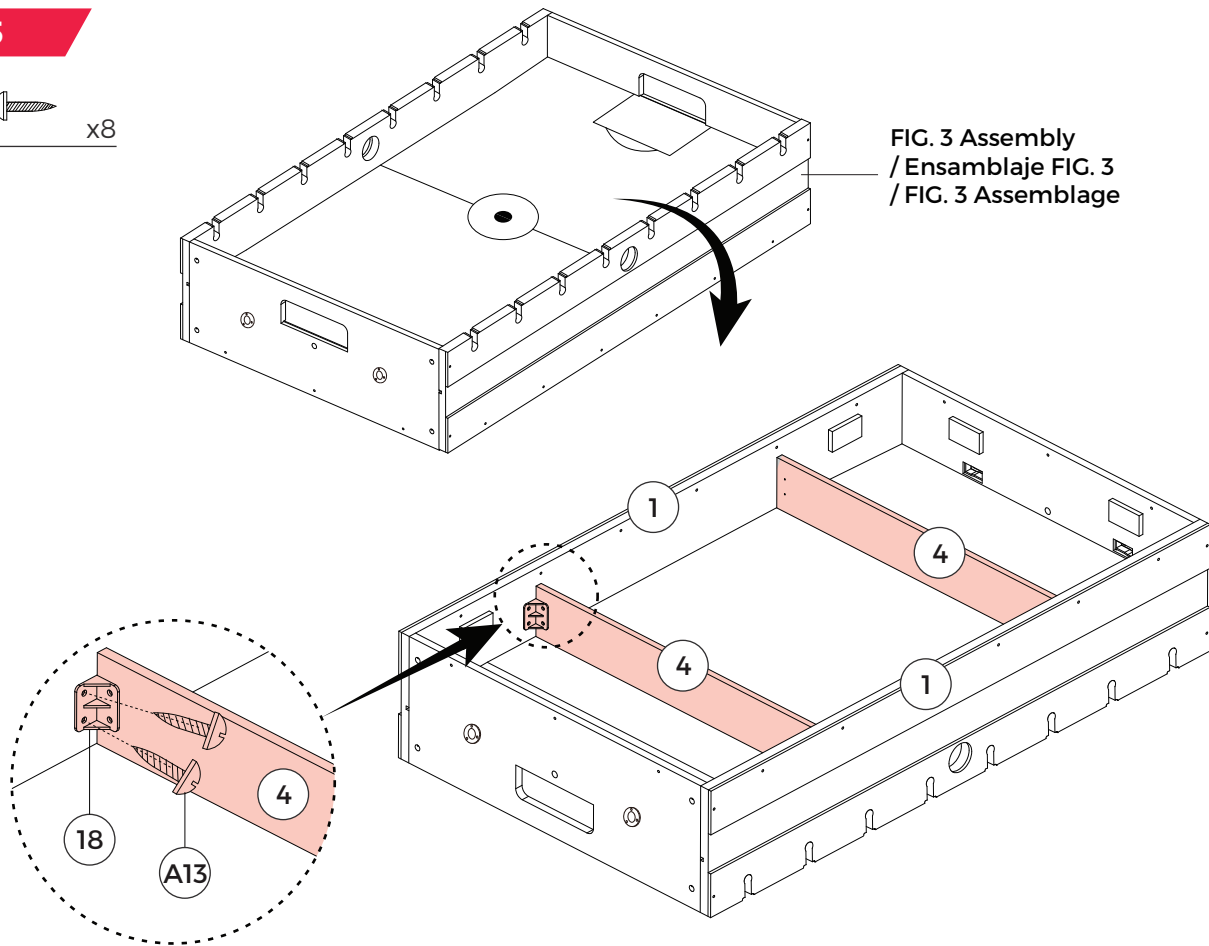



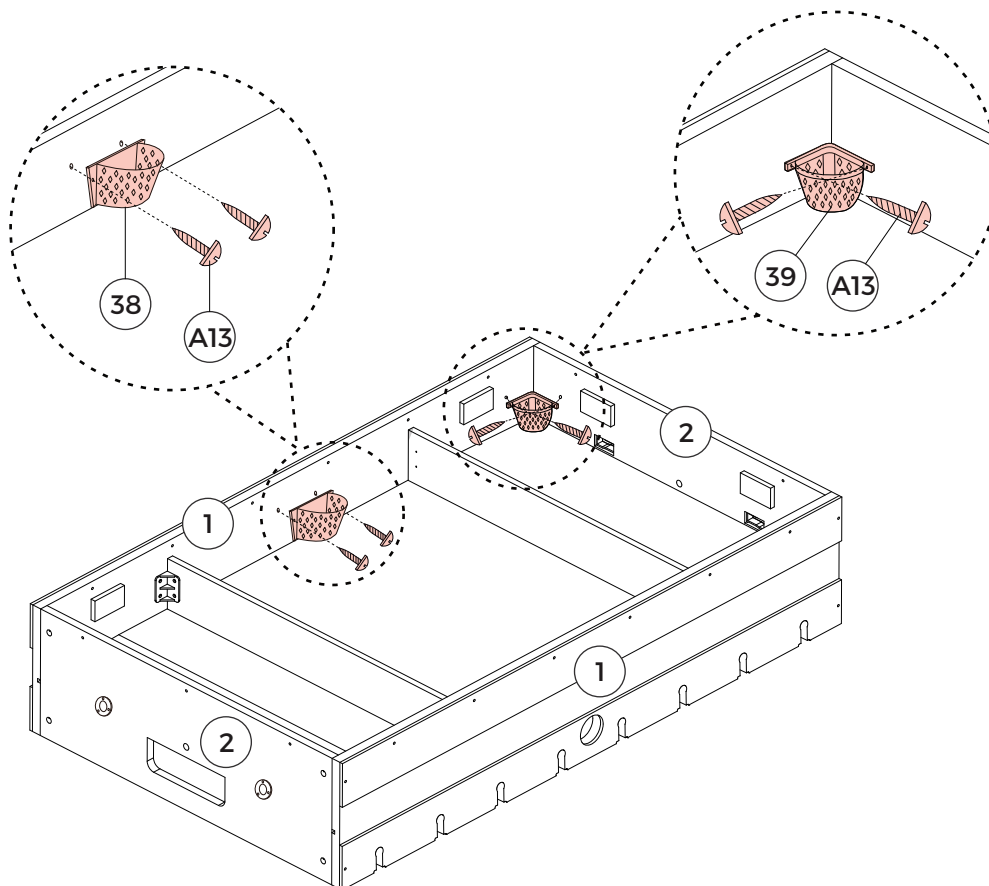

FIG. 3 Assembly
/ Ensamblaje FIG. 3
/ FIG. 3 Assemblage

FIG. 6

- 38  x2
- 39  x4
- A13  x12



ASSEMBLY

MONTAJE

ASSEMBLAGE

FIG. 7

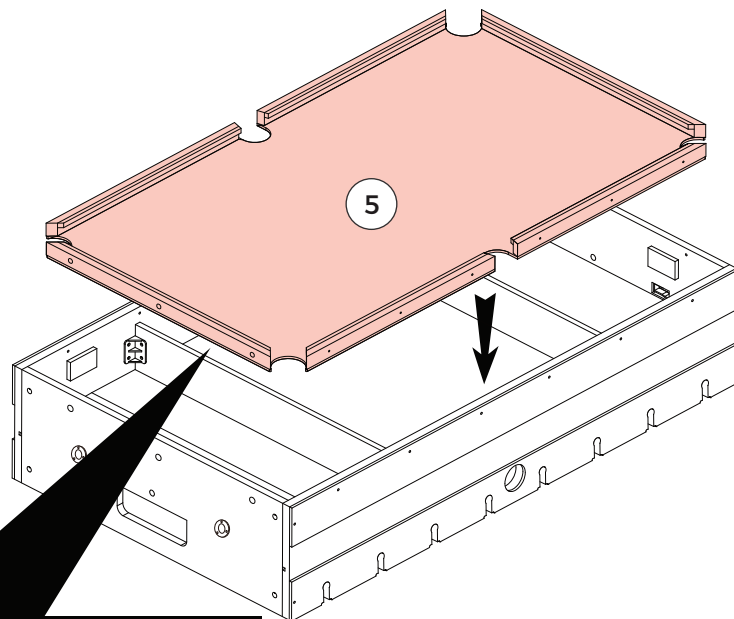
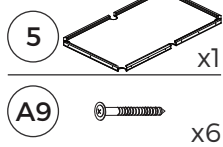

Note: Place the billiards playfield (5) flat and then lock with screws (A9).

Nota: Coloque el campo de juego de billar (5) plano y luego bloquee con tornillos (A9).

Nota : Placez le terrain de baby-foot (5) à plat puis verrouillez avec les vis (A9).

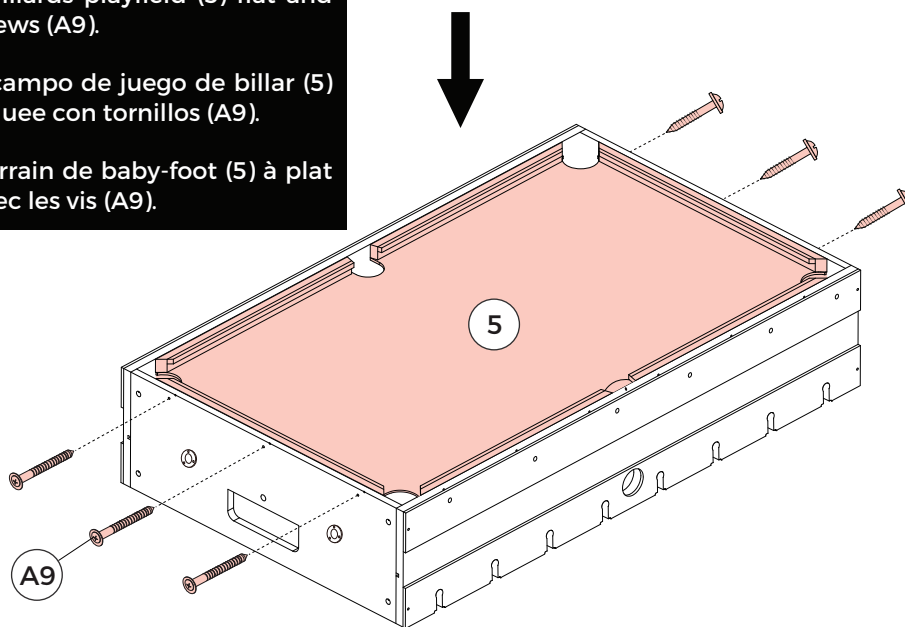
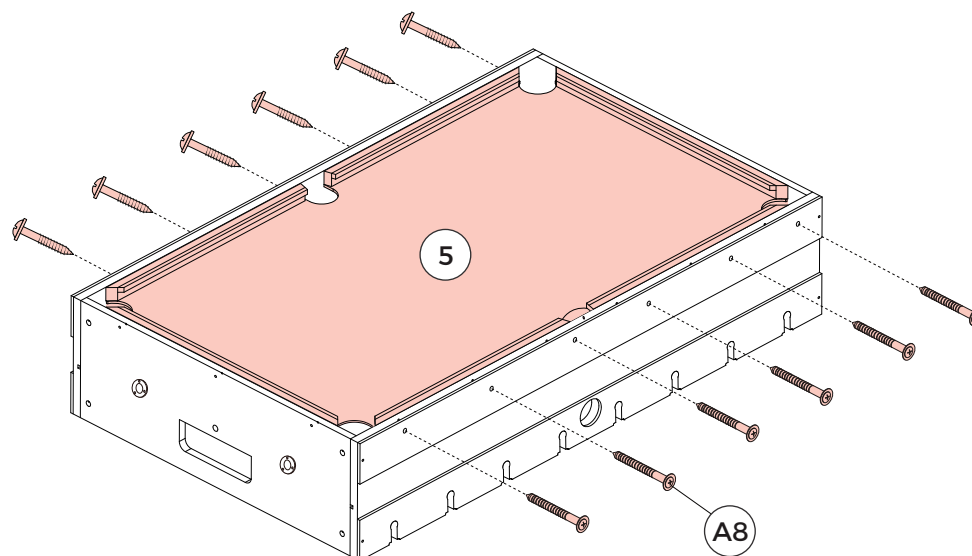

FIG. 8





ASSEMBLY

MONTAJE

ASSEMBLAGE

FIG. 9

- 40  x2
- 41  x4
- A5  x12

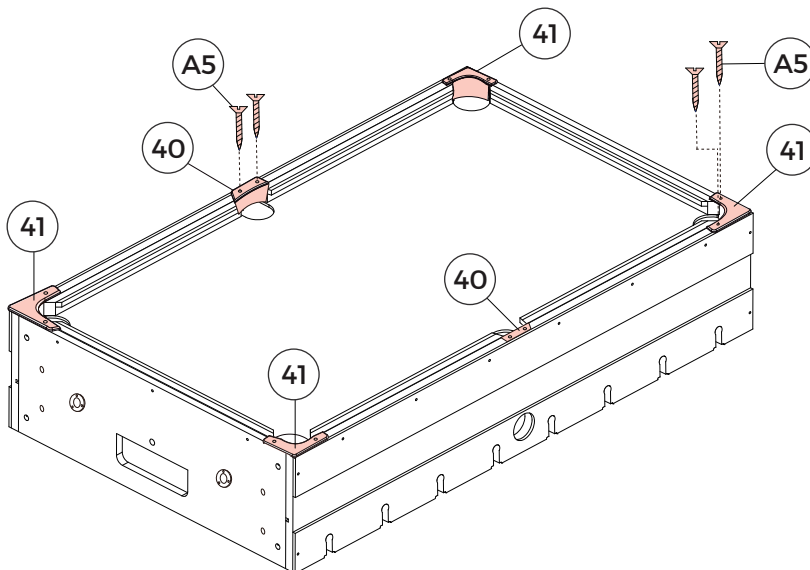



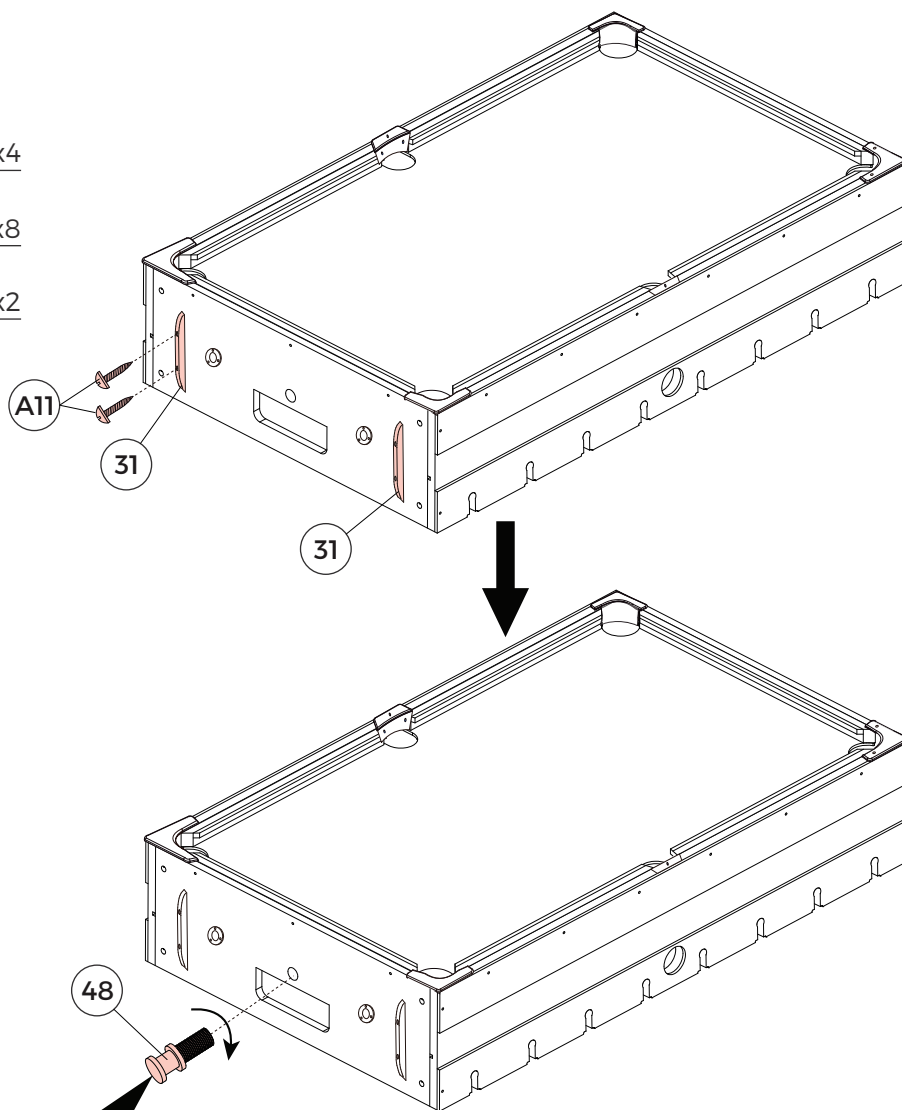

FIG. 10

- 31  x4
- A11  x8
- 48  x2







Note: Tighten it well by hand.
 Nota: Apretarlo bien a mano.
 Note: Bien serrer à la main.

ASSEMBLY

MONTAJE

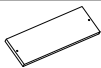
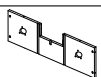
ASSEMBLAGE

FIG. 11

- 7  x4
- 8  x2
- 9  x2
Pre-installed
- P4  x8
- 29  x4
- A8  x12
- A13  x12

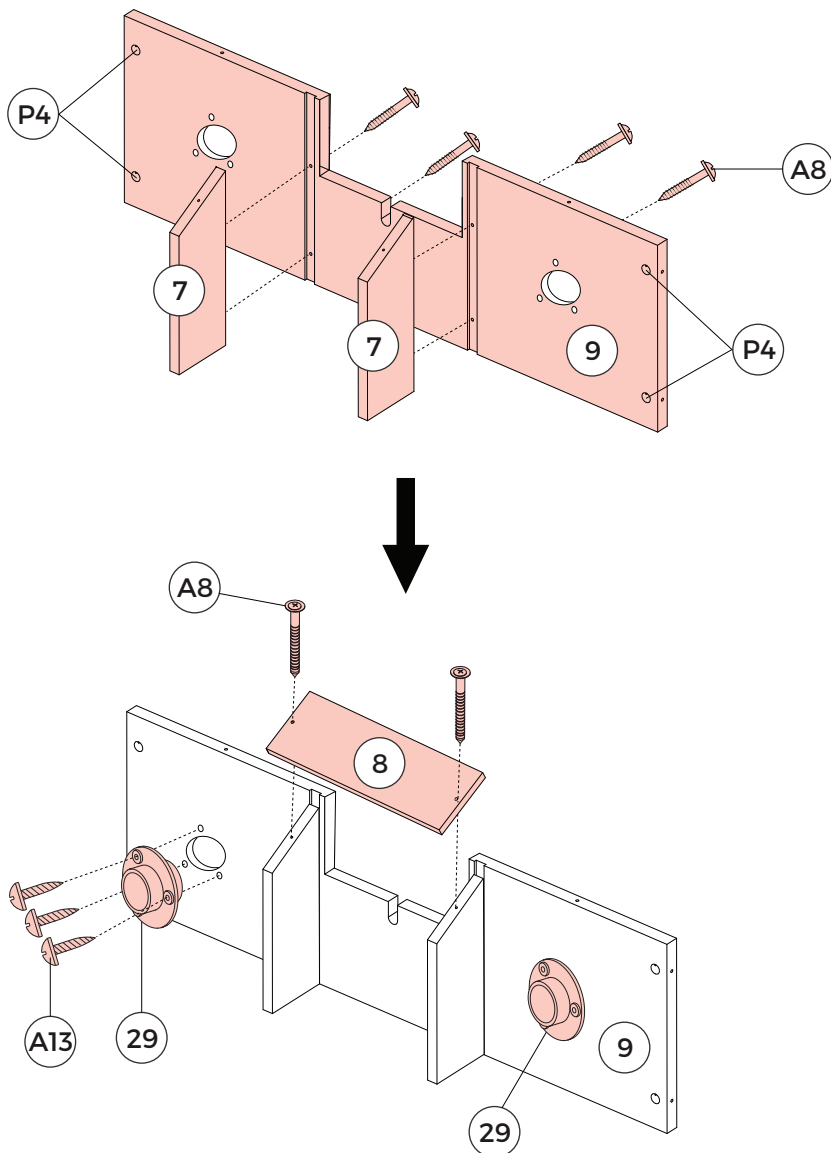
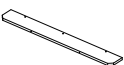
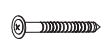
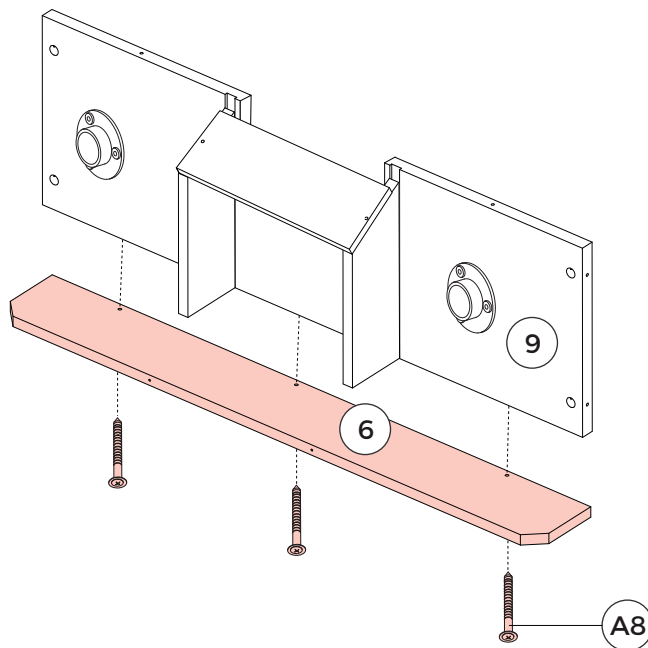

FIG. 12

- 6  x2
- A8  x6







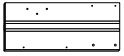
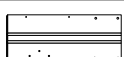

ASSEMBLY

MONTAJE

ASSEMBLAGE

FIG. 13

- 10  x2
- 11  x2
- P3  Pre-installed x8
- 17  x4
- P2  Pre-installed x4
- 33  x1
- A8  x12

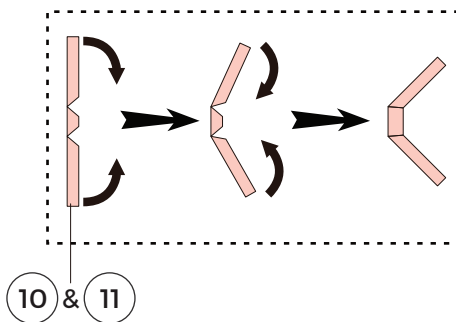

Note: Please fold the legs into a V configuration with the Nuts on the inside of the V.

Nota: Doble las piernas a la configuración V con las tuercas en el lado interno de la V.

Note: Veuillez replier les pieds en forme de V avec les écrous sur la partie intérieure du V.

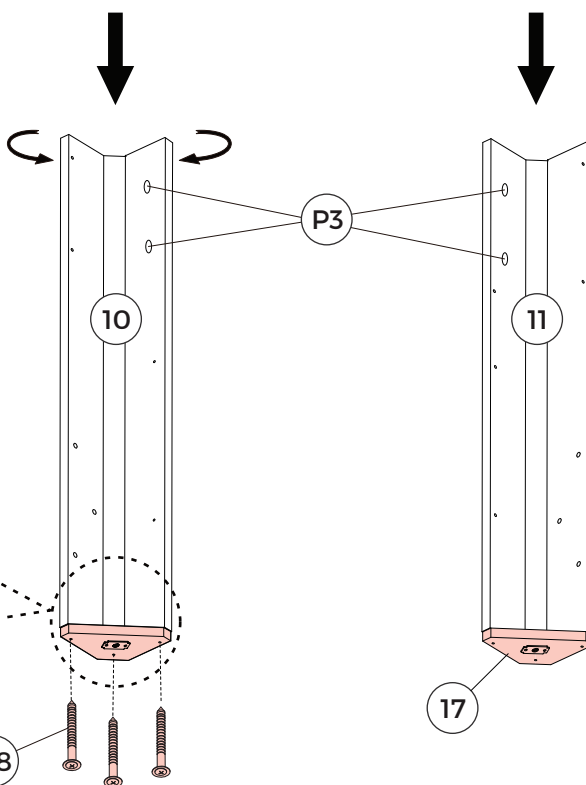
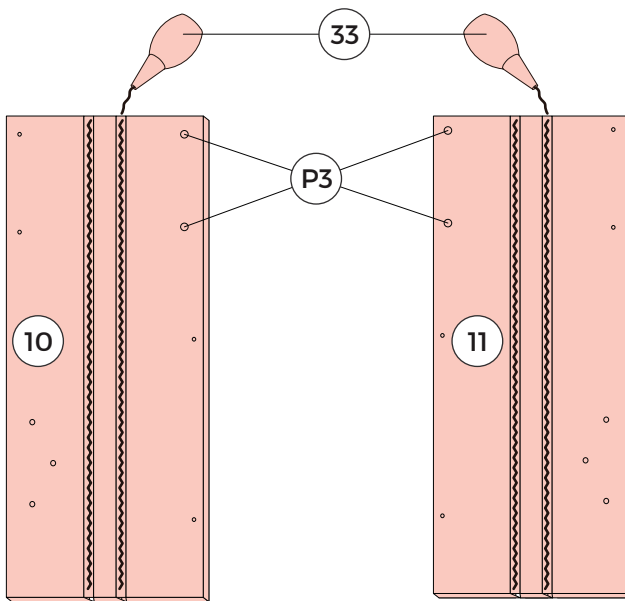

BOTTOM VIEW
/ VISTA INFERIOR
/ VUE DE DESSOUS

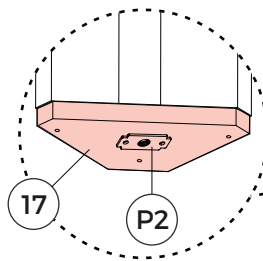





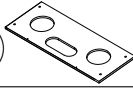

ASSEMBLY

MONTAJE

ASSEMBLAGE

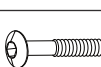
FIG. 14

- 12**  x2
Pre-installed
- P5**  x2
Pre-installed
- P6**  x4
- A3**  x8
- A4**  x8
- A12**  x8
- A14**  x1

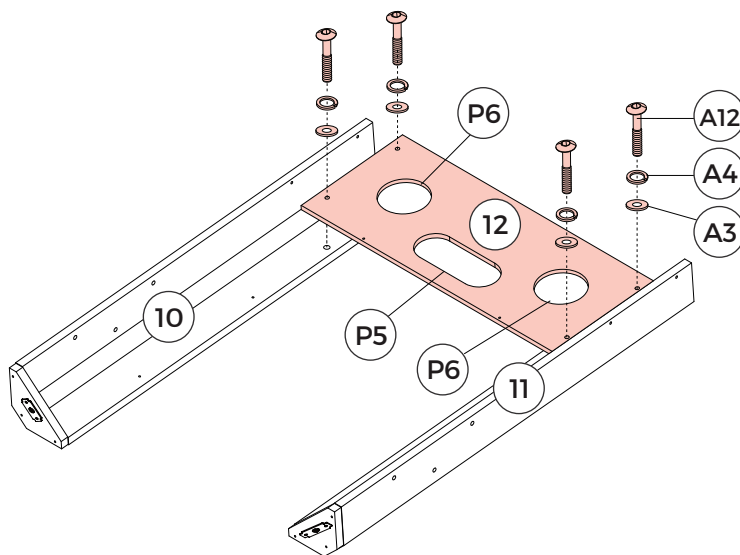

FIG. 15

- A8**  x4

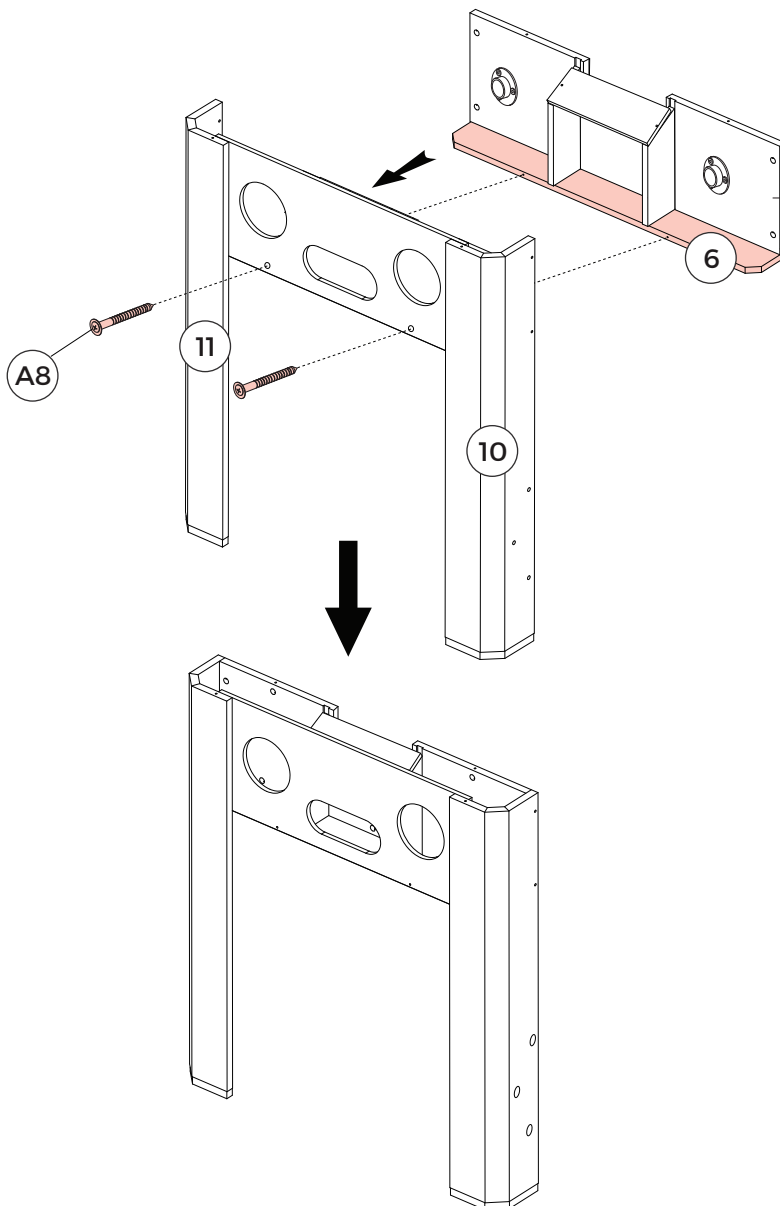





FIG. 12 Assembly
/ Ensamblaje FIG. 12
/ FIG. 12 Assemblage

ASSEMBLY

MONTAJE

ASSEMBLAGE

FIG. 16

- 13  x2
- 32  x4
- A8  x8
- A13  x8

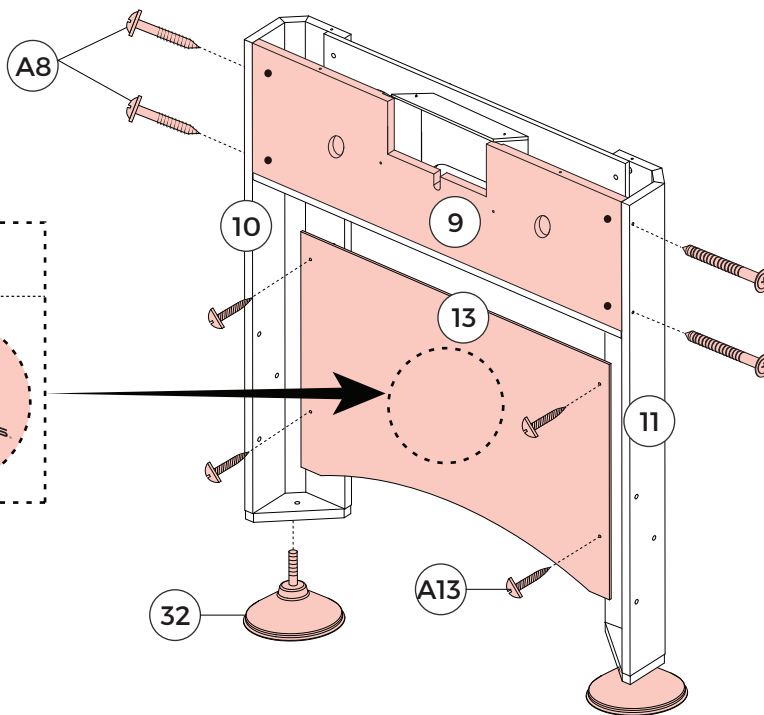
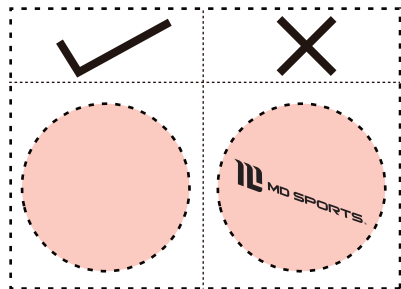





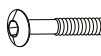



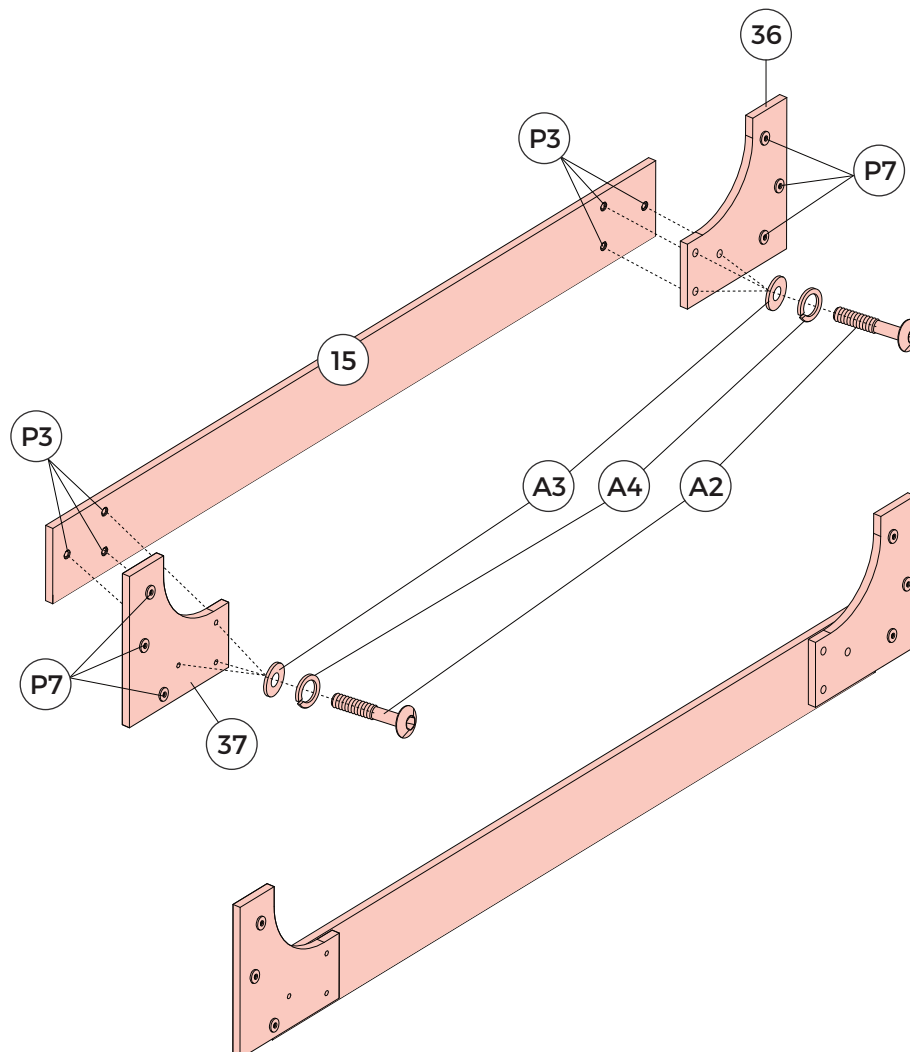

FIG. 17

- 15  x2
- P3  x12
Pre-installed
- 36  x2
- 37  x2
- P7  x12
Pre-installed
- A2  x12
- A3  x12
- A4  x12
- A14  x1







ASSEMBLY

MONTAJE

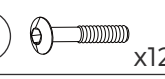
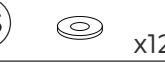
ASSEMBLAGE

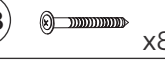
FIG. 18

-  25 x2
-  A1 x12
-  A3 x12
-  A4 x12
-  A8 x8
-  A14 x1

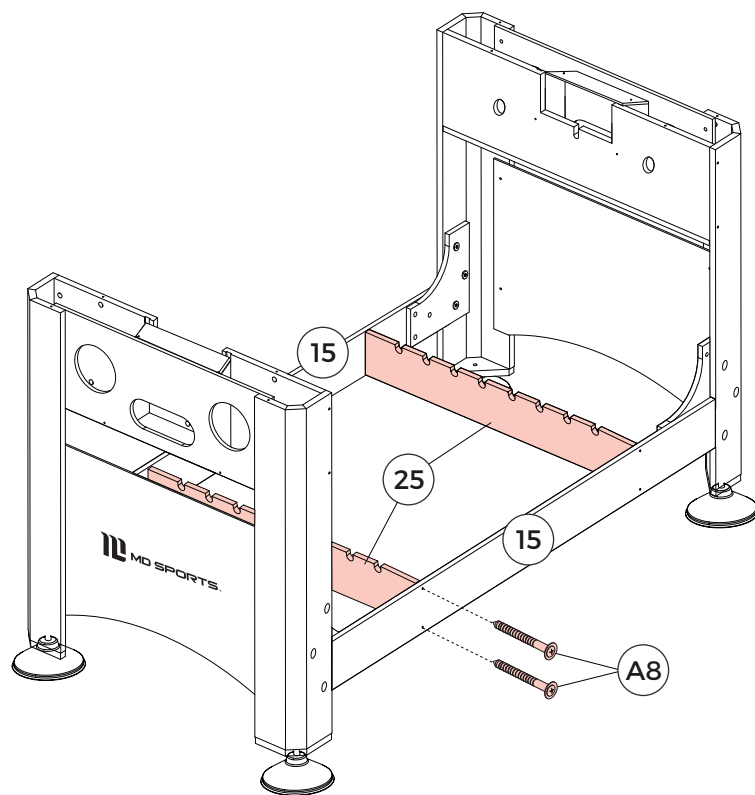
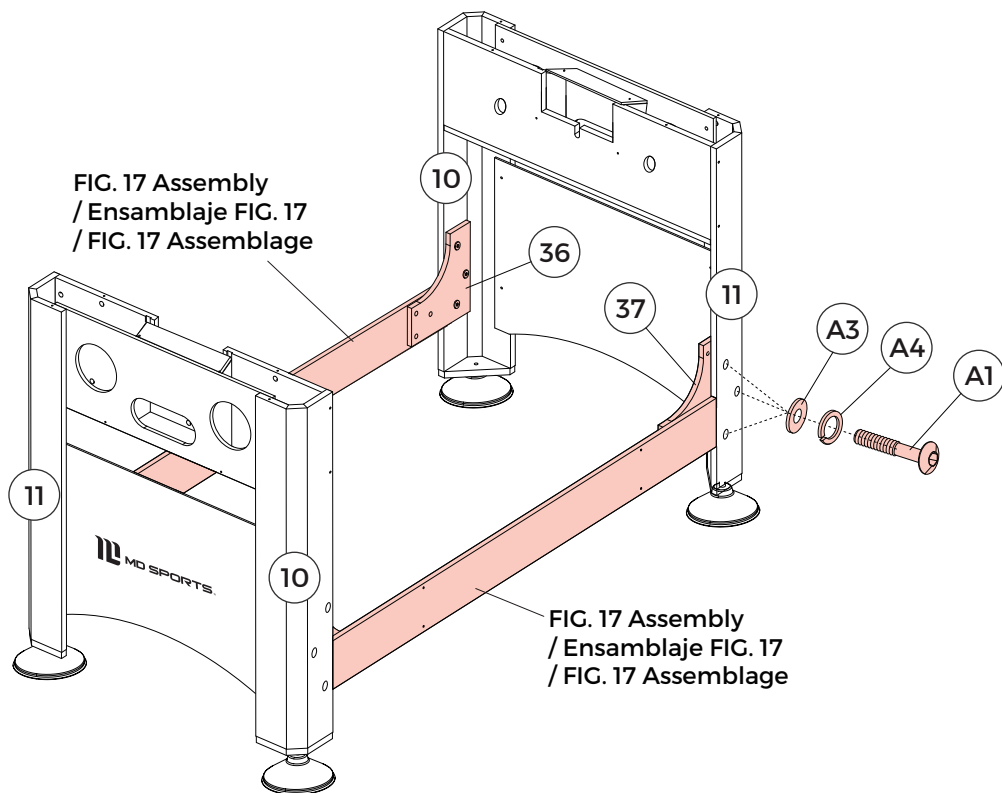
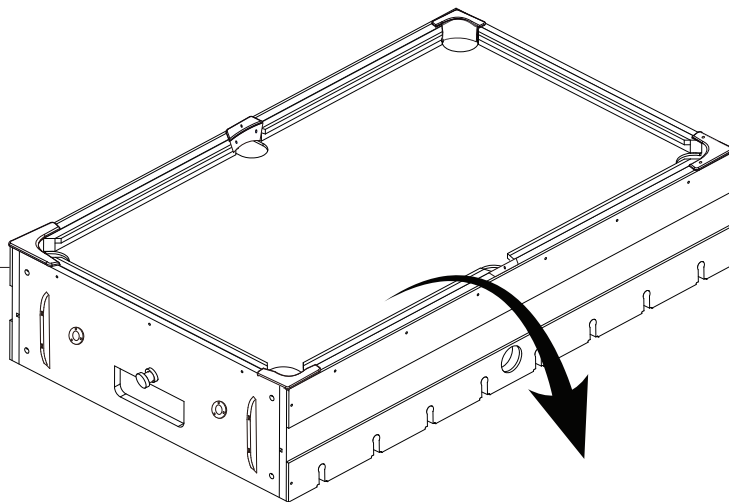
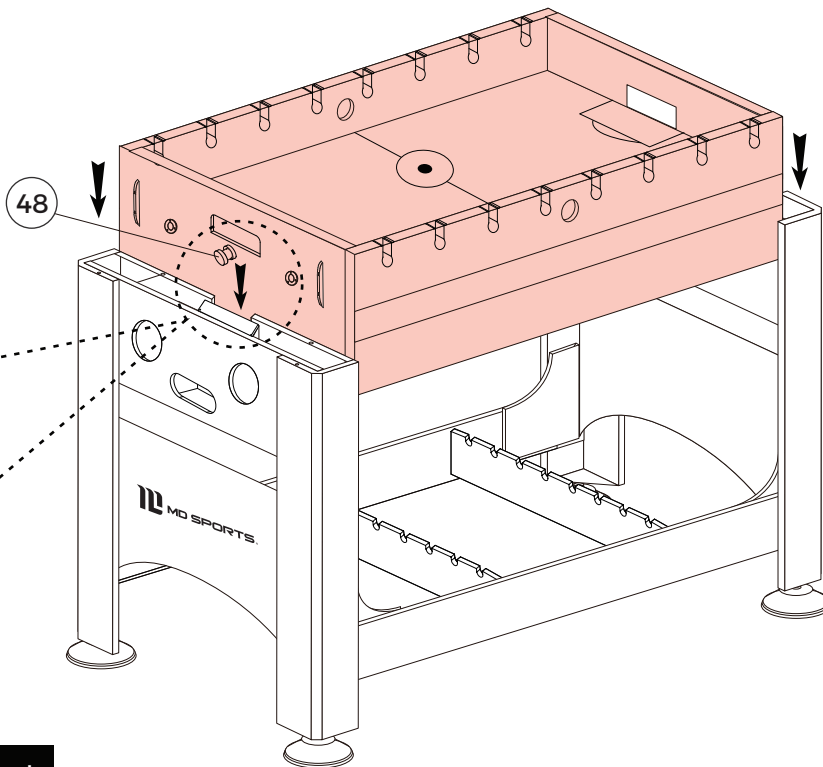
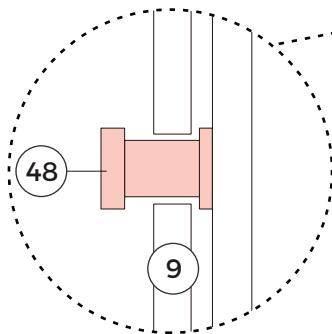

FIG. 19

FIG. 10 Assembly
/ Ensamblaje FIG. 10
/ FIG. 10 Assemblage



TOP VIEW
/ VISTA SUPERIOR
/ VUE DU HAUT



Note: Proper swivel bolt placement.

Nota: Perno enroscado de arandela.

Note: Placement correct pivotant et de la rondelle.

ASSEMBLY

MONTAJE

ASSEMBLAGE

FIG. 20

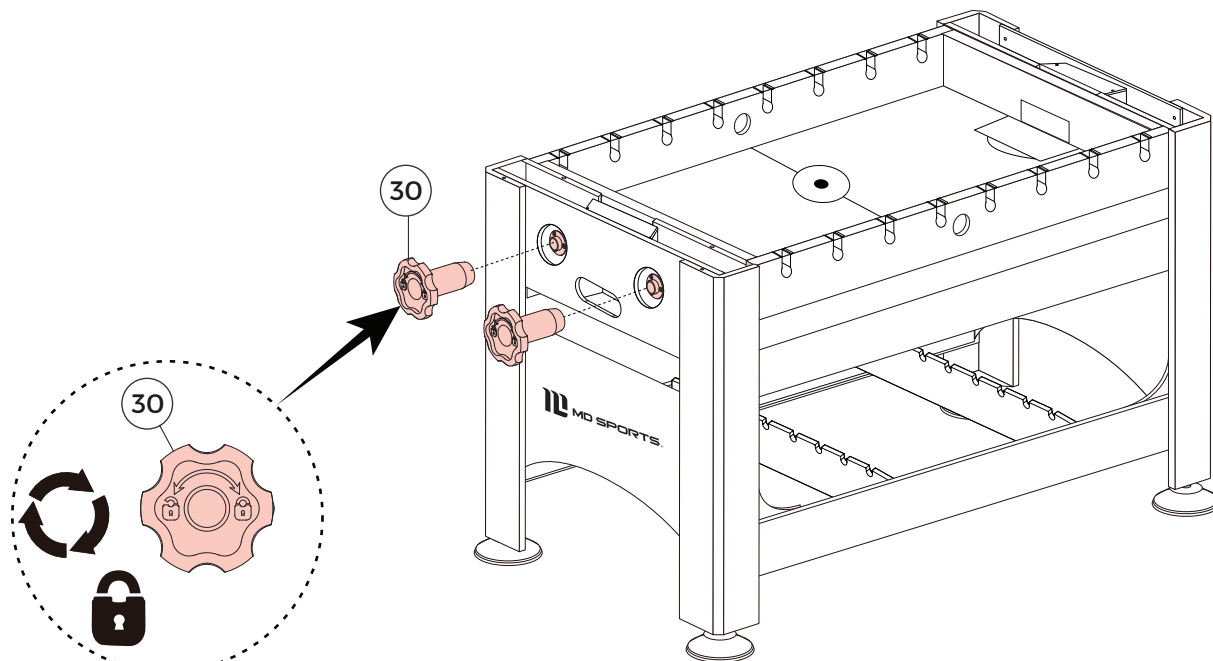
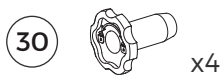

Note: Use locking knob (30) to secure the table top.

Nota: Use la perilla de cerradura (30) para asegurar la parte superior de mesa.





Note: Fixez la partie supérieure de table en utilisant le bouton de verrouillage (30).

ASSEMBLY

MONTAJE

ASSEMBLAGE

FIG. 21

- 16  x2
- 35  x2
- A5  x2
- A7  x8

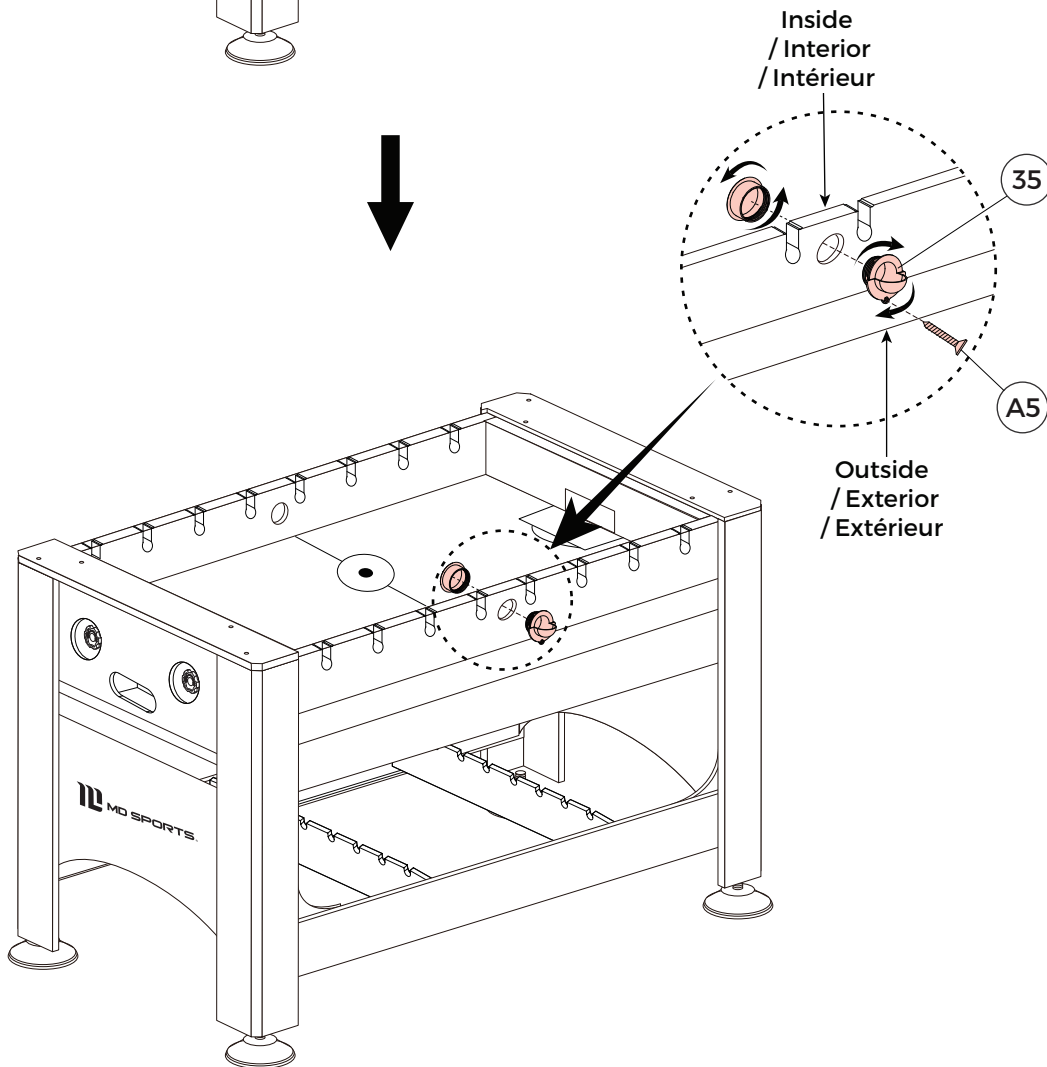
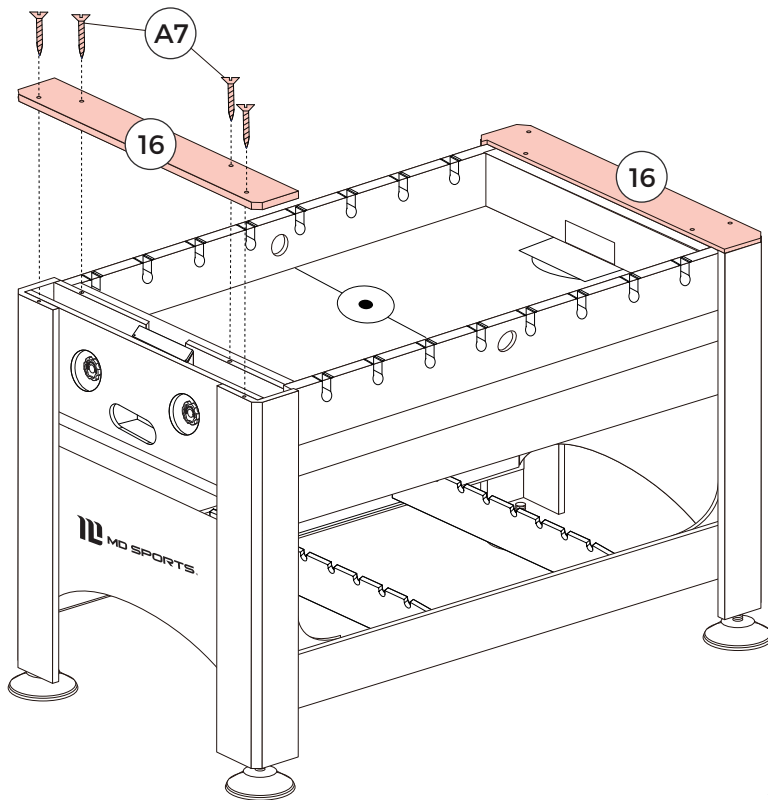









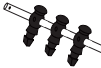
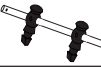

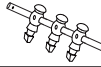
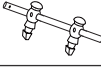
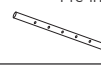
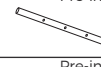

ASSEMBLY

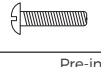
MONTAJE

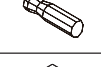
ASSEMBLAGE

FIG. 22

- 19**  x1
- 20**  x2
- 21**  x1
- 22**  x1
- 23**  x2
- 24**  x1
Pre-installed
- P10**  x2
Pre-installed
- P11**  x4
Pre-installed
- P12**  x2
Pre-installed
- P13**  x13
Pre-installed
- P14**  x13
Pre-installed
- P15**  x26
Pre-installed
- P16**  x26
- 27**  x8
- 28**  x8
- 44**  x16
- 46**  x16
- 47**  x16

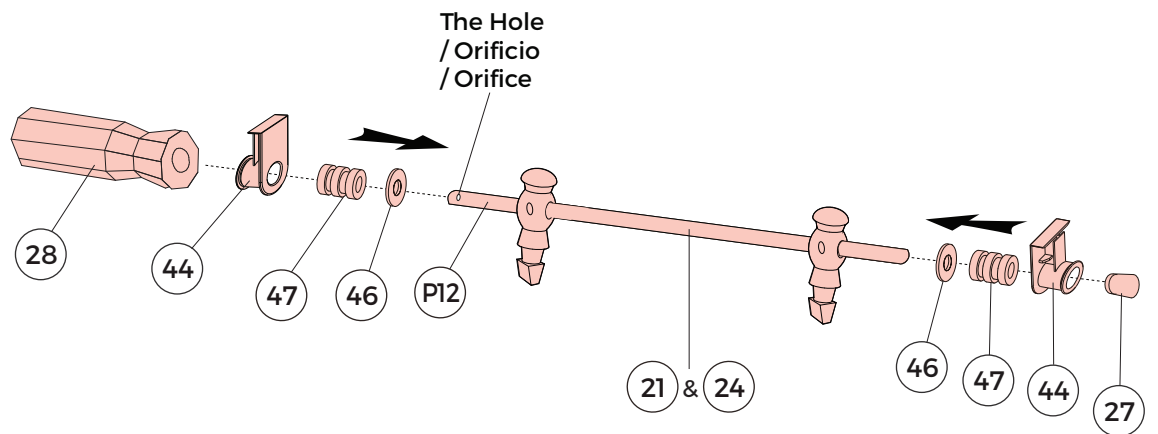
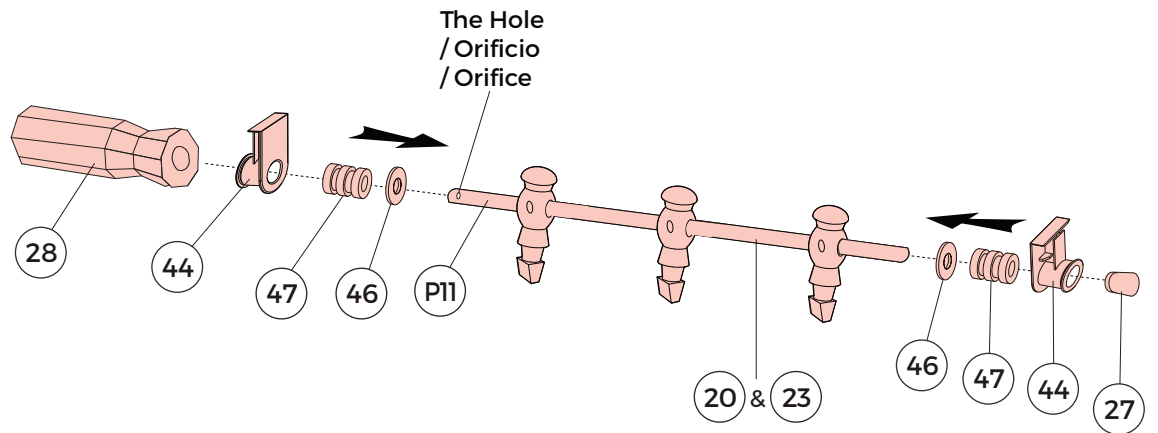
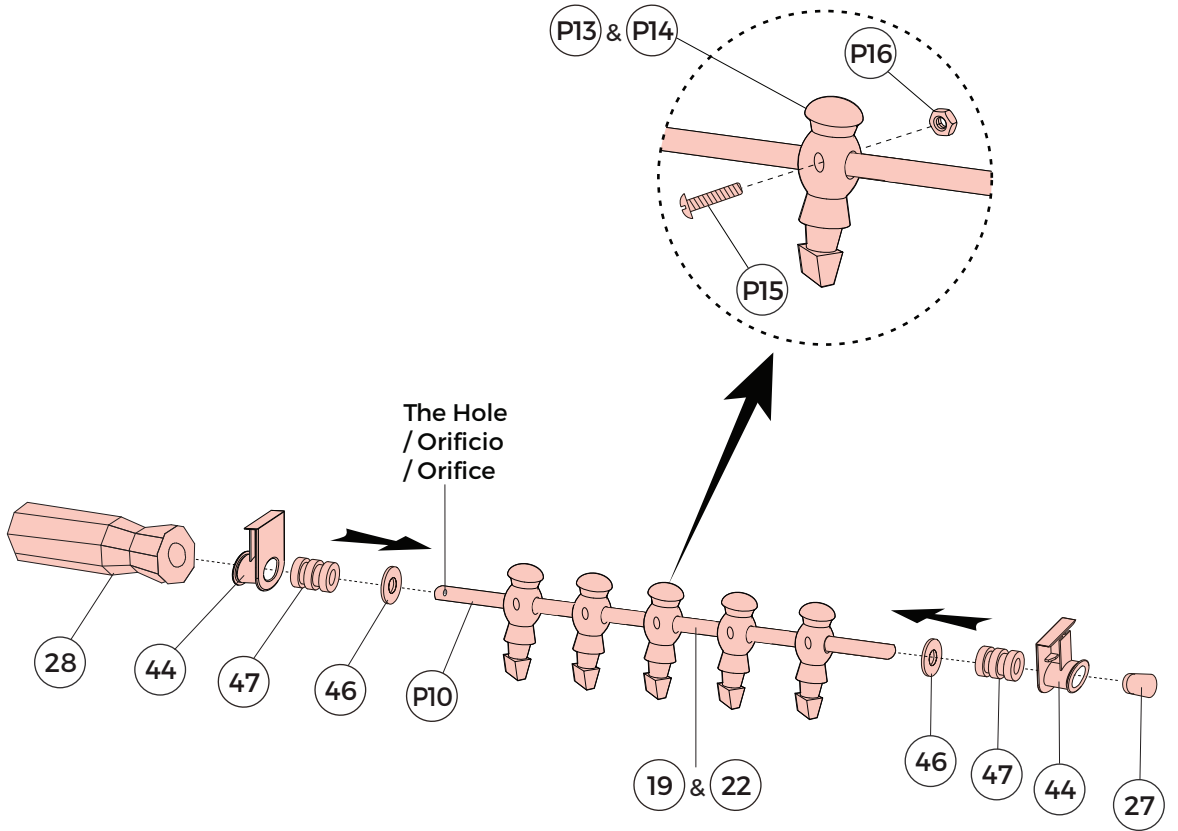

ASSEMBLY

MONTAJE

ASSEMBLAGE

FIG. 23

- 45  x16

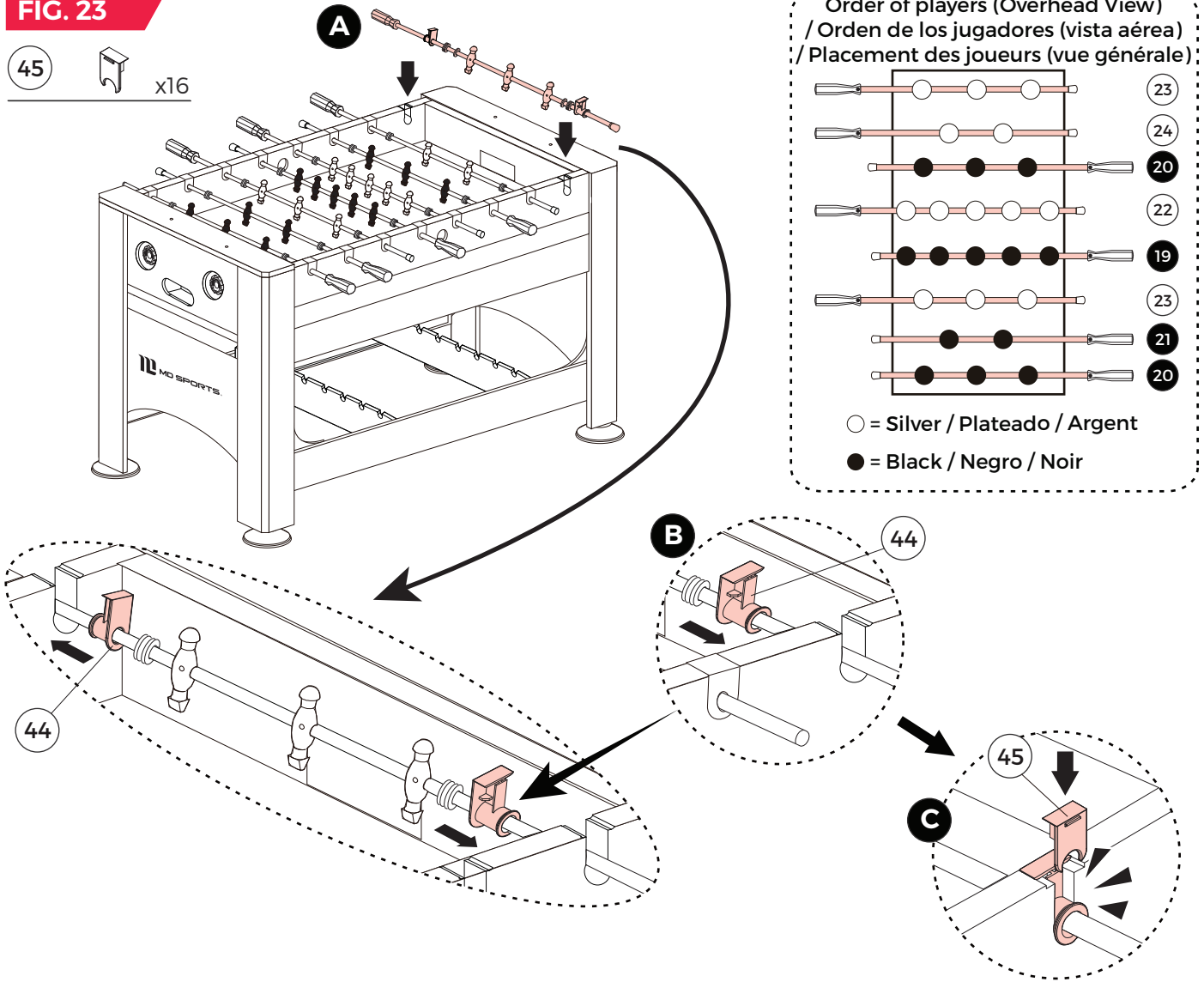



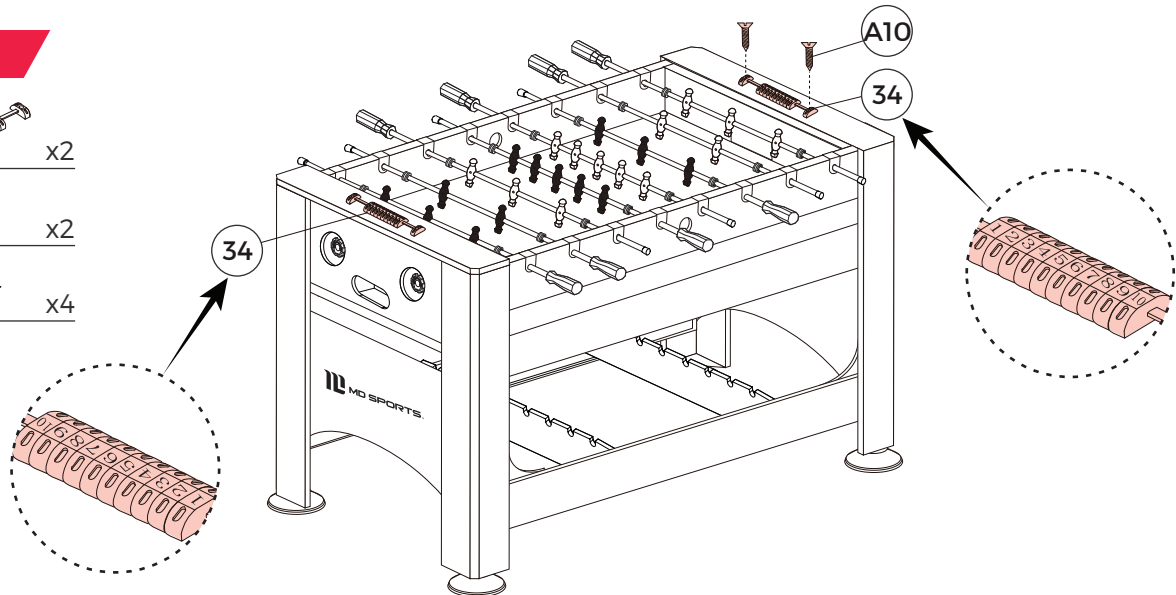

FIG. 24

- 34  x2
- 55  x2
- A10  x4



GAME 1: Soccer

JUEGO 1: Fútbol

JEU 1: Foot

ASSEMBLY

MONTAJE

ASSEMBLAGE

FIG. 25

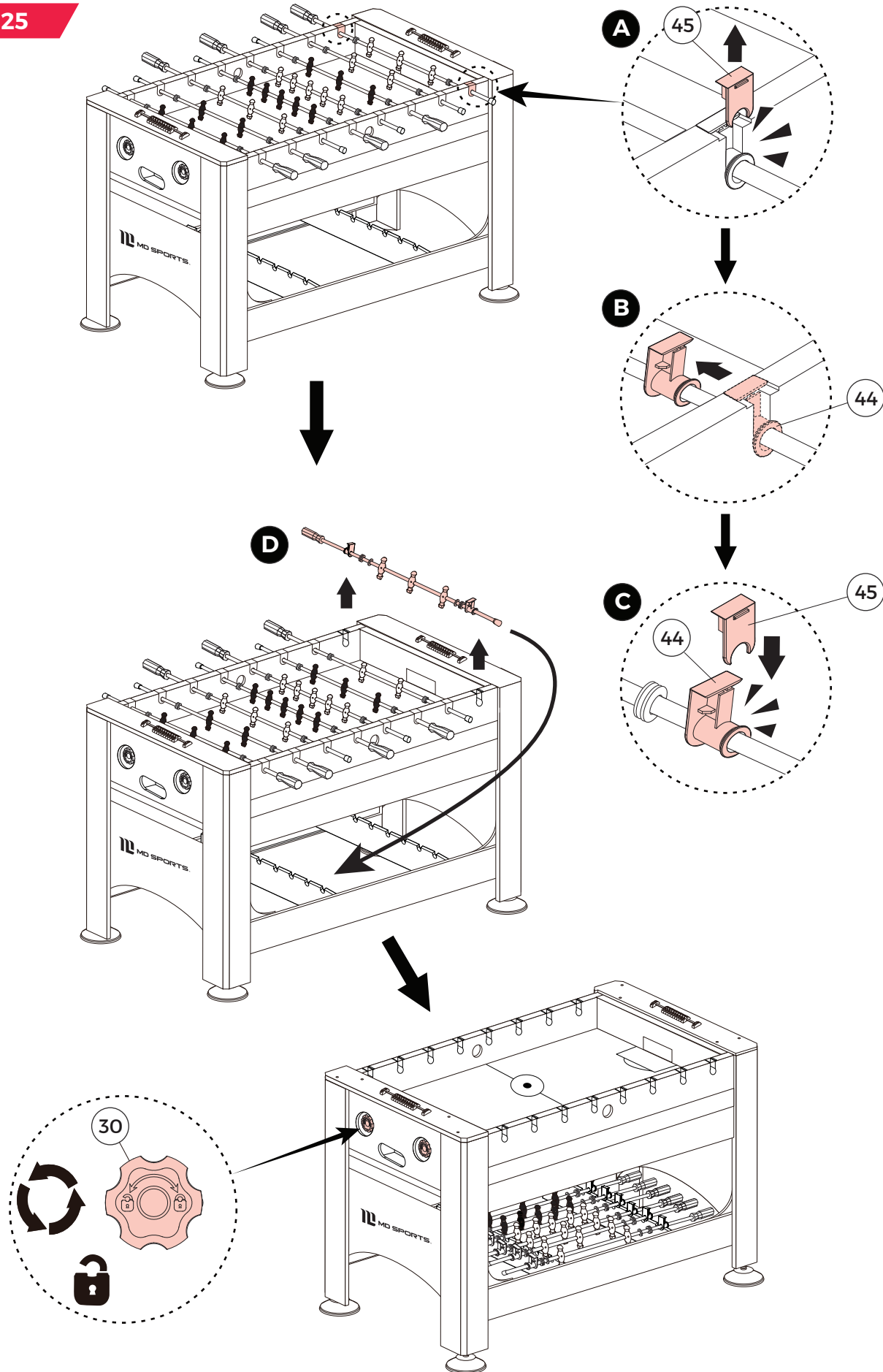







ASSEMBLY

MONTAJE

ASSEMBLAGE

FIG. 26

- 49  x2
- 50  x1
- 51  x1
- 52  x1
- 53  x2
- 54  x2

Note: When flipping the table to play billiards, remove the rod with players on the football table first.

Nota: Al voltear la mesa para jugar al billar, primero retire la varilla con los jugadores en la mesa de fútbol.

Note: Lorsque vous renversez la table pour jouer au billard, retirez d'abord la tige avec les joueurs sur la table de baby-foot.

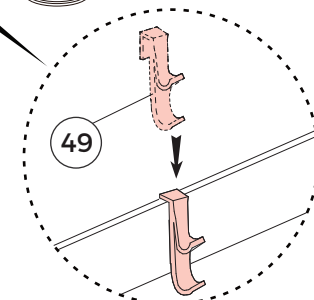
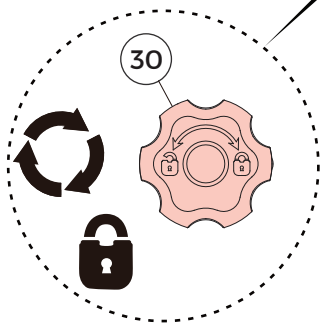
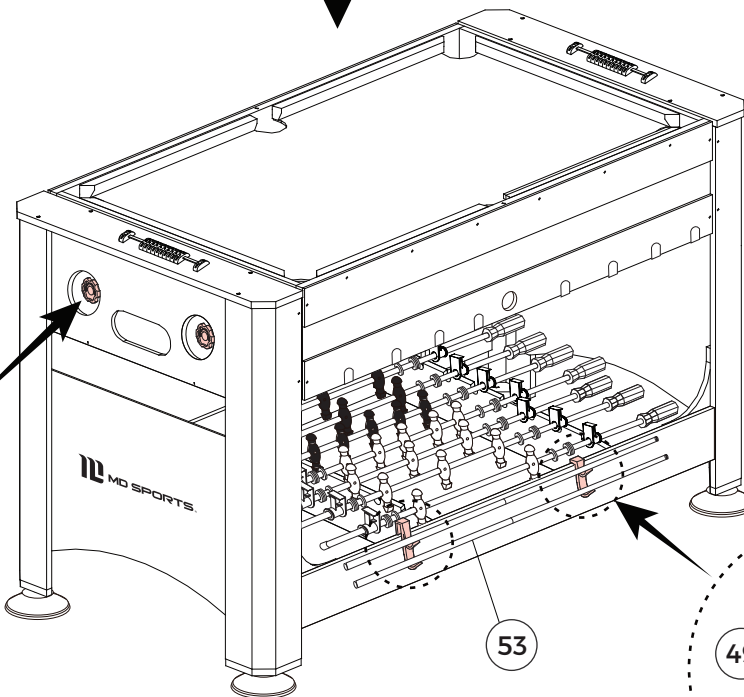
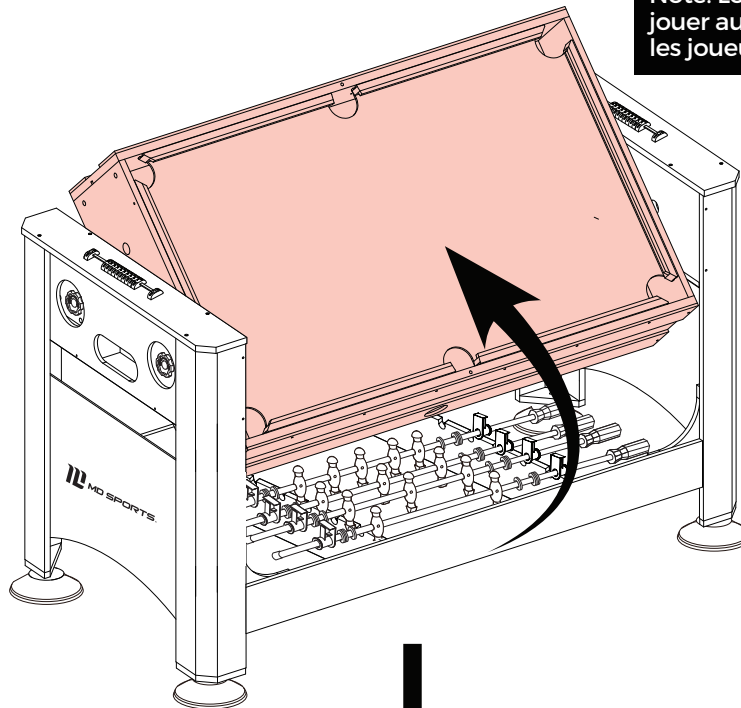

GAME 2: Billiard

JUEGO 2: Billar

JEU 2: Billard

ASSEMBLY

MONTAJE

ASSEMBLAGE

FIG. 27

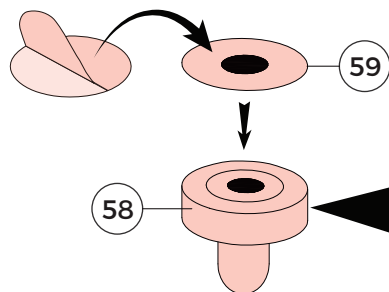
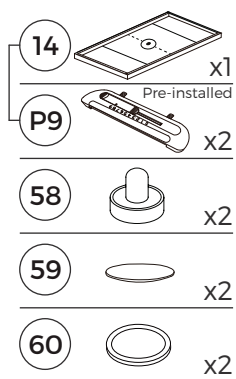

Note: Tear off the backside papers of the Felt Pads (59) and stick them into the bottom of the Pushers (58).

Nota: Retire el papel de la parte trasera de la almohadilla de fieltro (59) y péguela en la parte inferior del mazo (58).

Note : Ôtez les papiers placés derrière les coussinets en feutre (59) et collez ceux-ci sur la base des Ipousseurs (58).

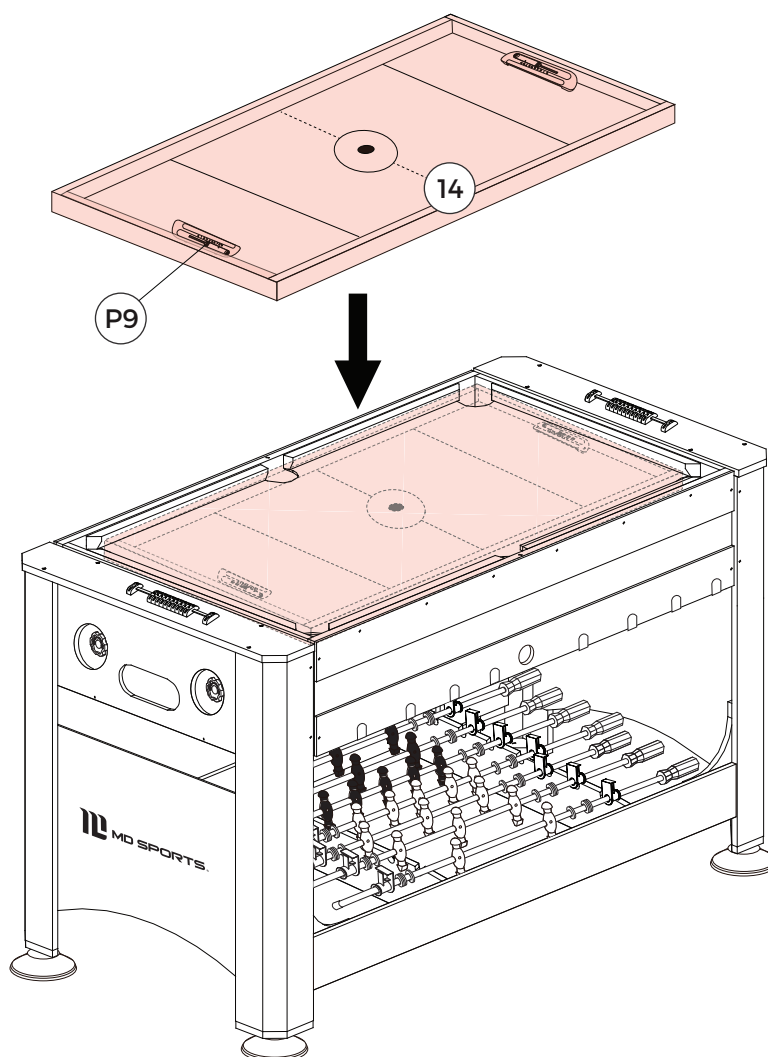

GAME 3: Slide Hockey

JUEGO 3: Hockey de mesa





JEU 3: Hockey sur glissade

ASSEMBLY

MONTAJE

ASSEMBLAGE

FIG. 28

- 26  x1
- 42  x1
- 43  x2
- 56  x2
- 57  x2

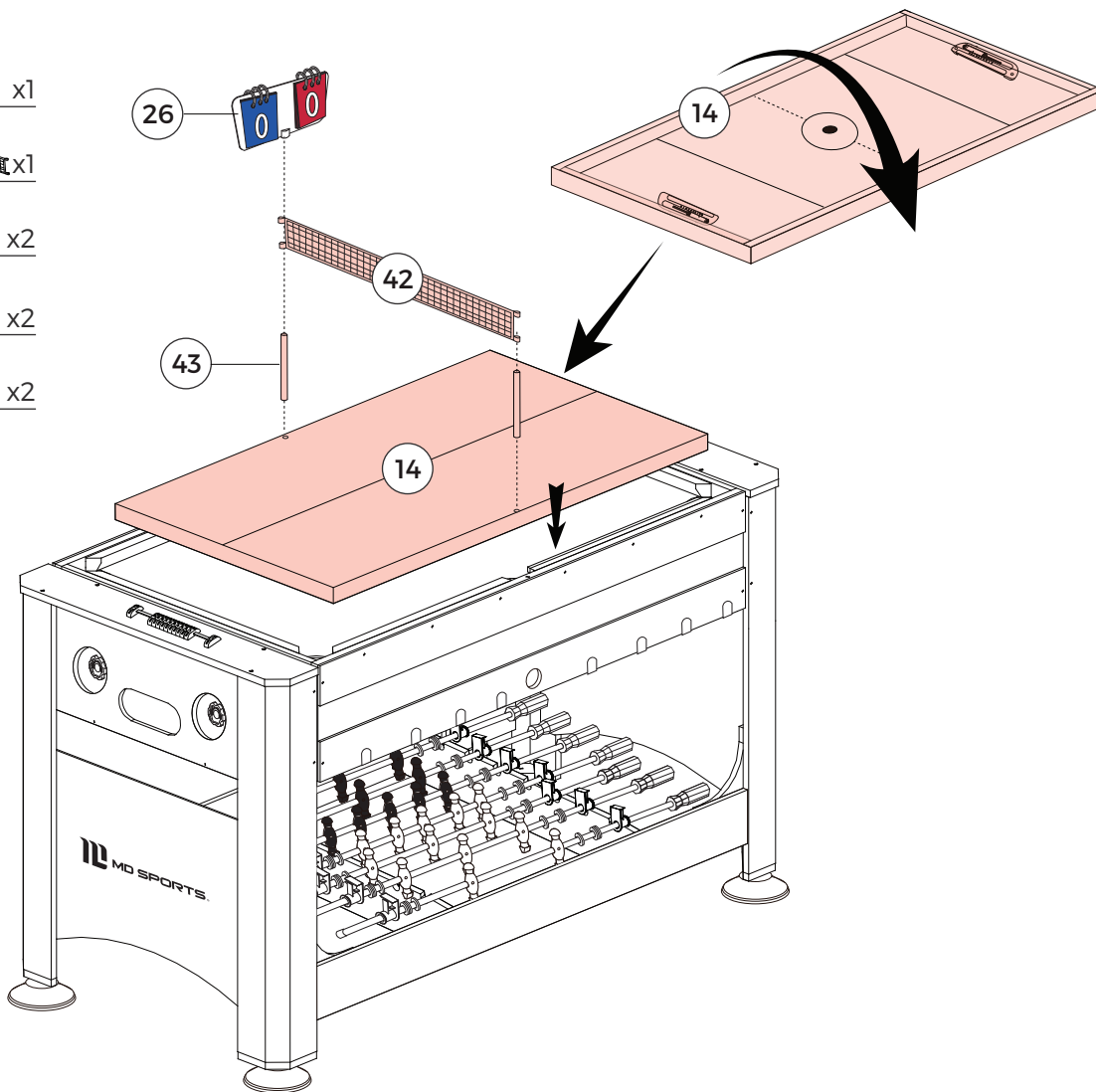

GAME 4: Table Tennis

JUEGO 4: Tenis de mesa

JEU 4: Tennis de table



