

MKS DLC32 User Manual

This document is the basic hardware and firmware description of MKS DLC32, which is convenient for beginners or users who are not familiar with MKS DLC32.

If your question is deeper, or the documentation doesn't mention it.

*Please don't worry, you can contact us through **Amazon** information or email [\(makerbase123@126.com\)](mailto:makerbase123@126.com),*

we will try our best to help you solve the problem.

This document is divided into 3 parts

[MKS DLC32 Hardware Interface](#)

[MKS DLC32 update firmware](#)

[Q&A of MKS DLC32](#)

MKS DLC32 Hardware Interface

Wiring :

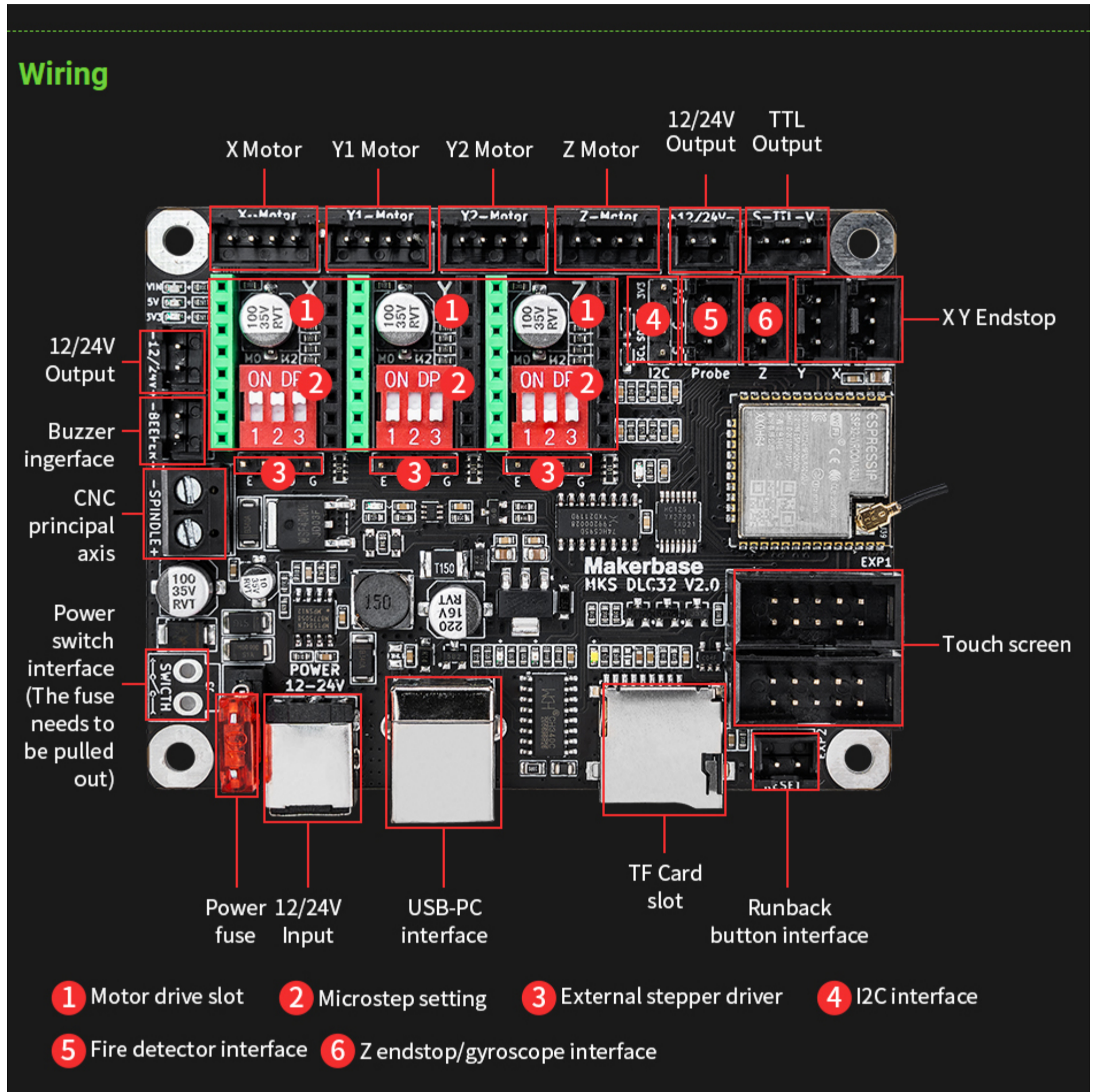

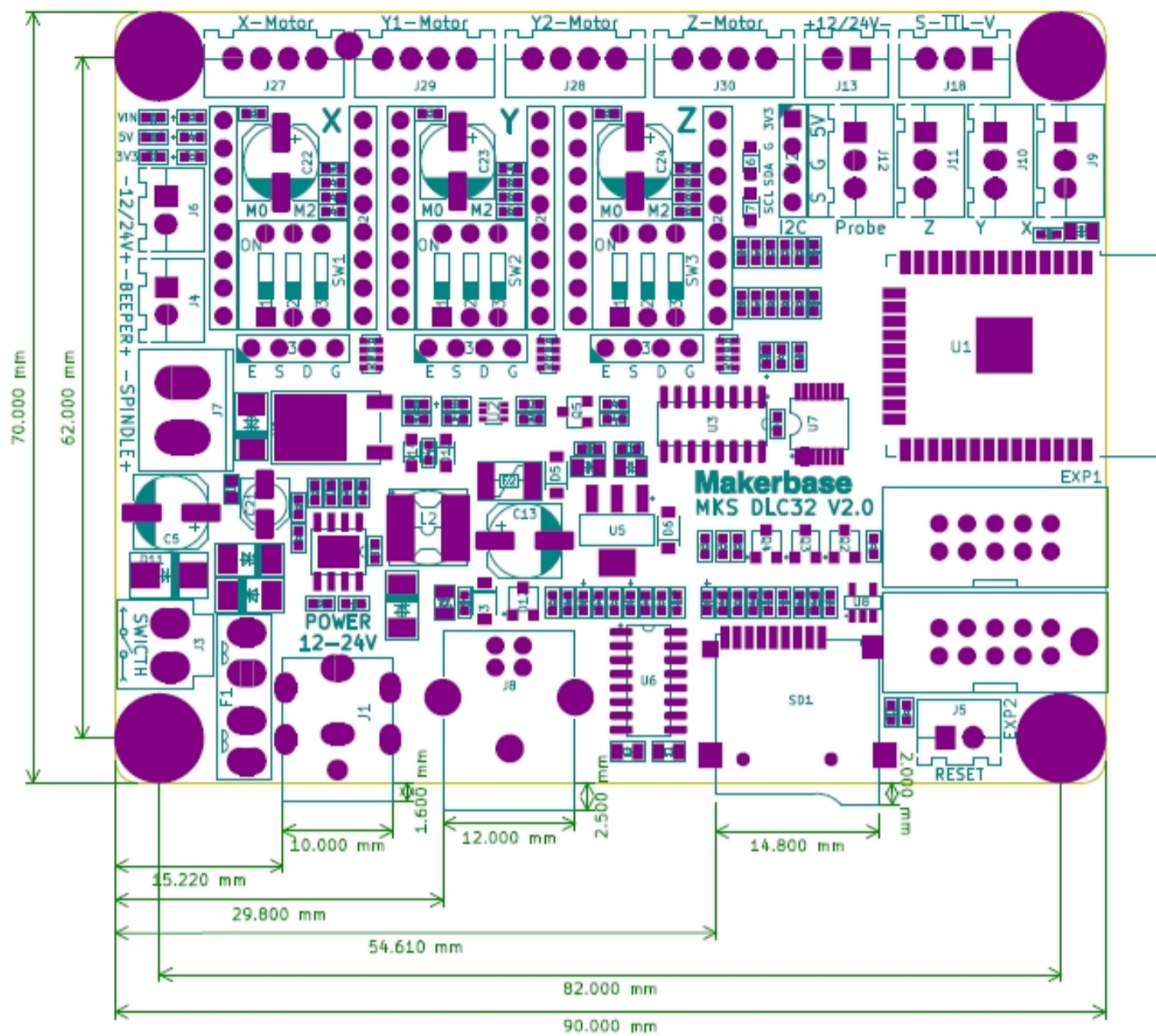

After you receive the motherboard, first check whether the appearance of the motherboard is complete. Then you can connect according to the interface marked in the picture according to the wiring of your Machine.

POWER PART

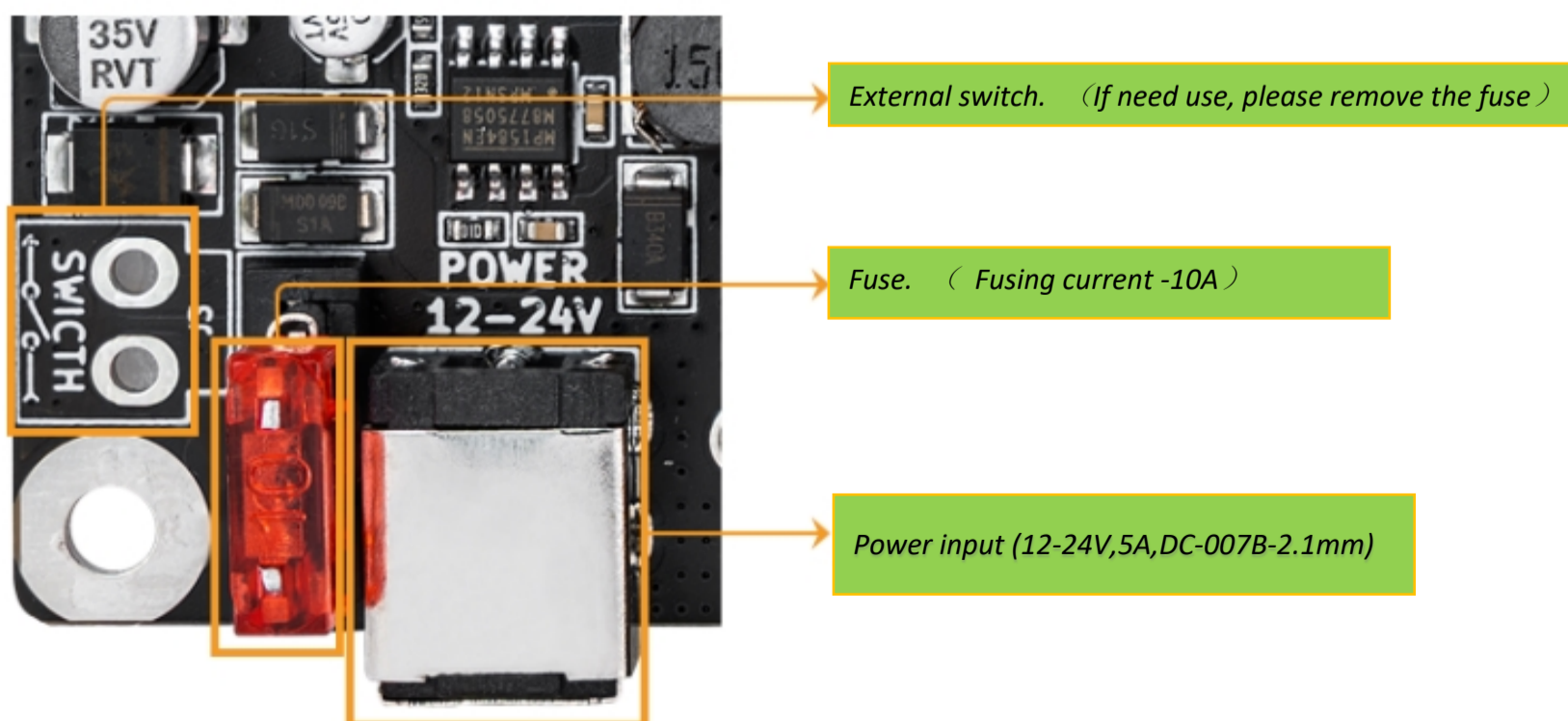

MOTOR PART

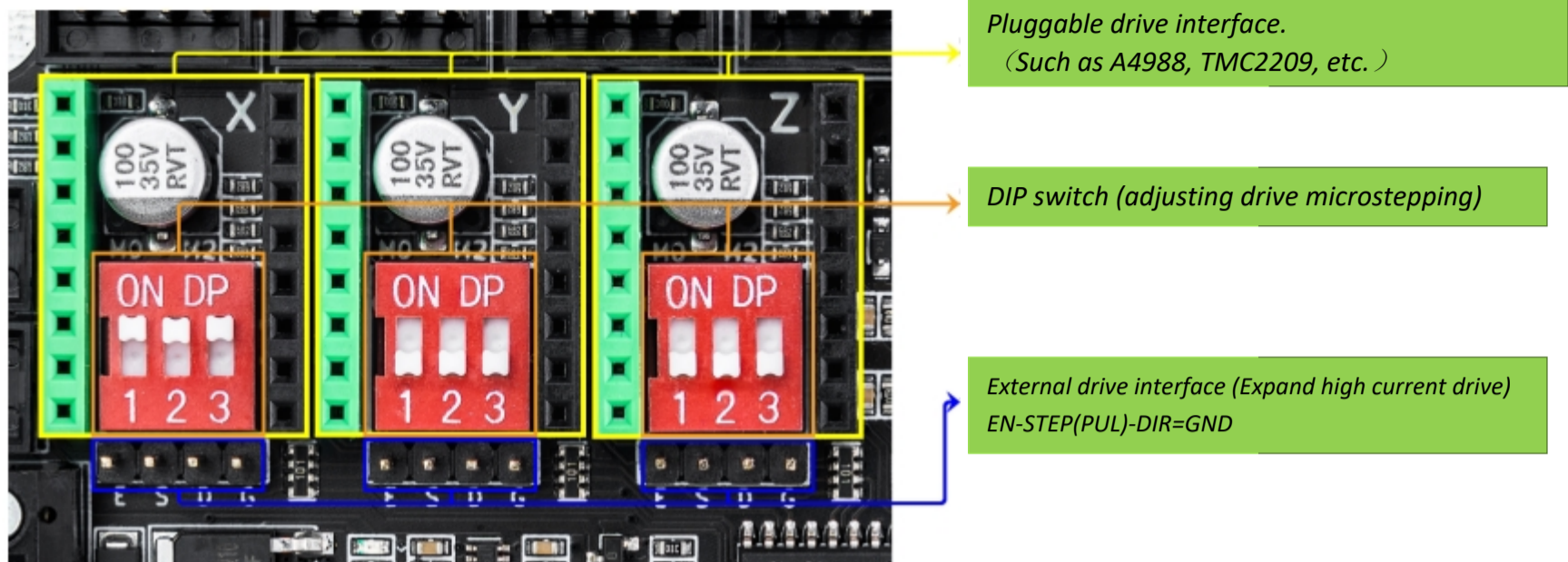

LASER/CNC PART

LASER-3PIN-TTL

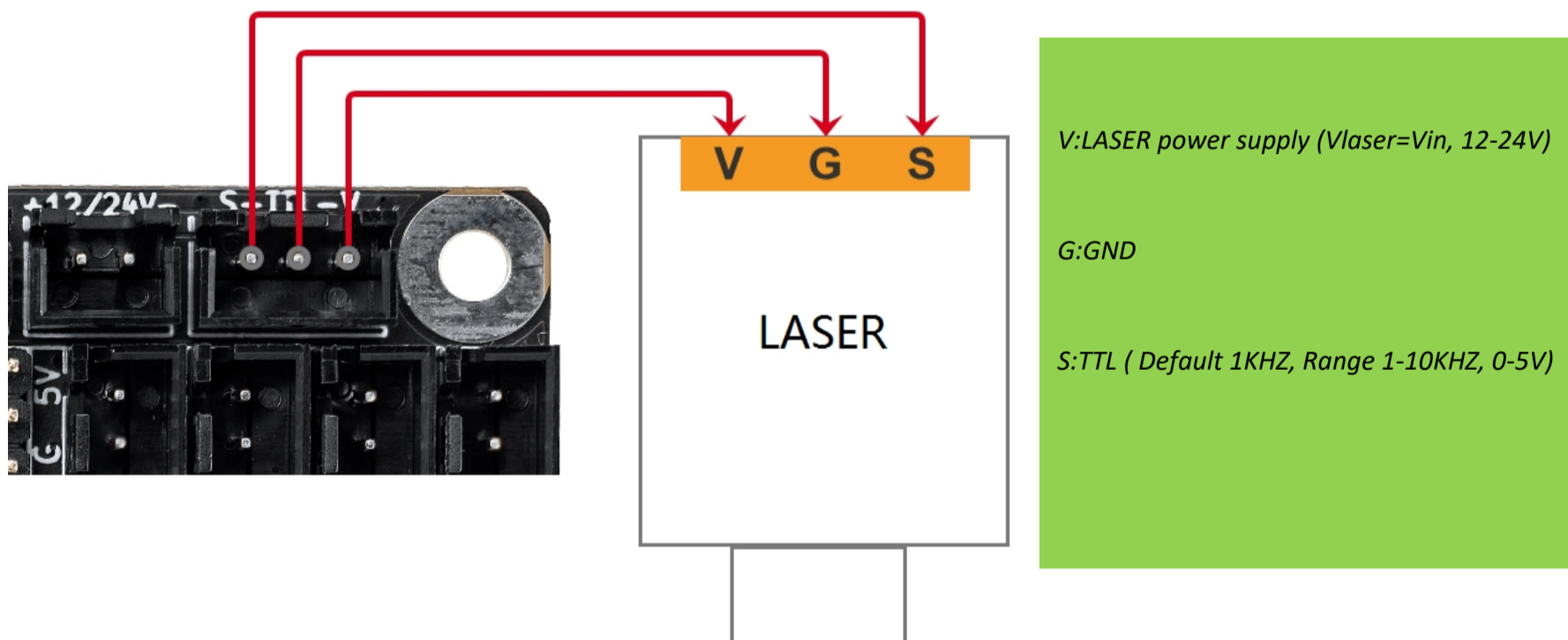

LASER-2PIN/CNC

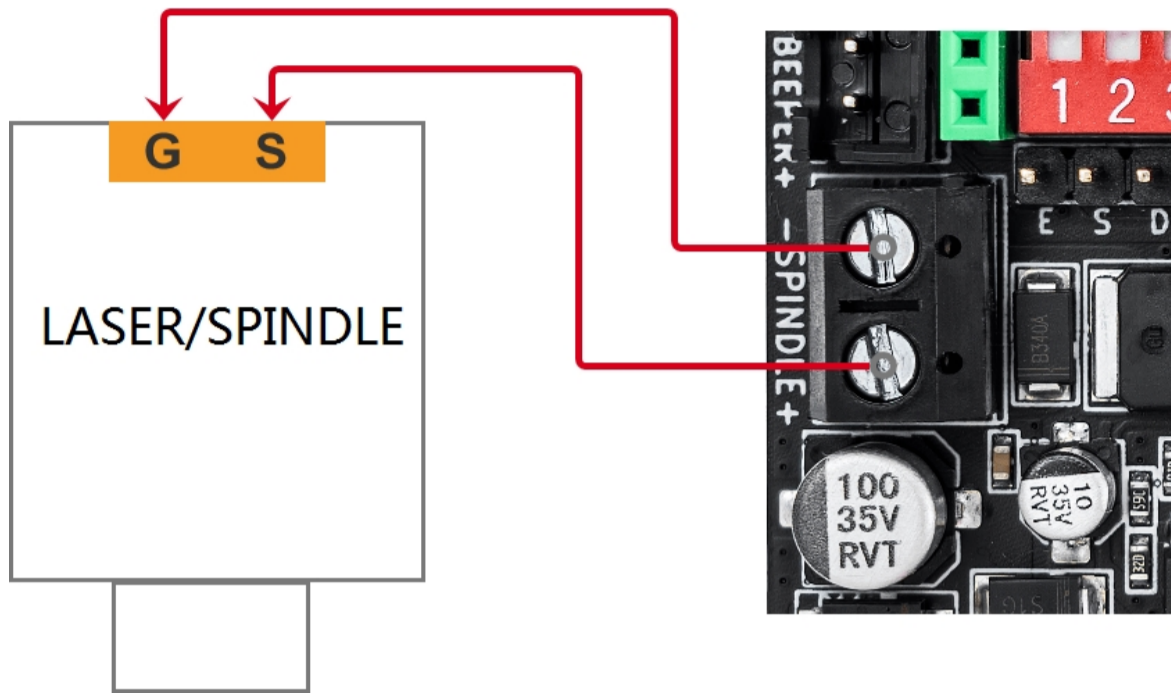

G:GND

S:PWM (PWM signal, 0-12V OR 0-24V)

NOTE: If the laser/cnc directly loaded by the motherboard, it is recommended that the current should not exceed 2A

If more power is required, it is recommended to supply additional power to the load

LCD PART

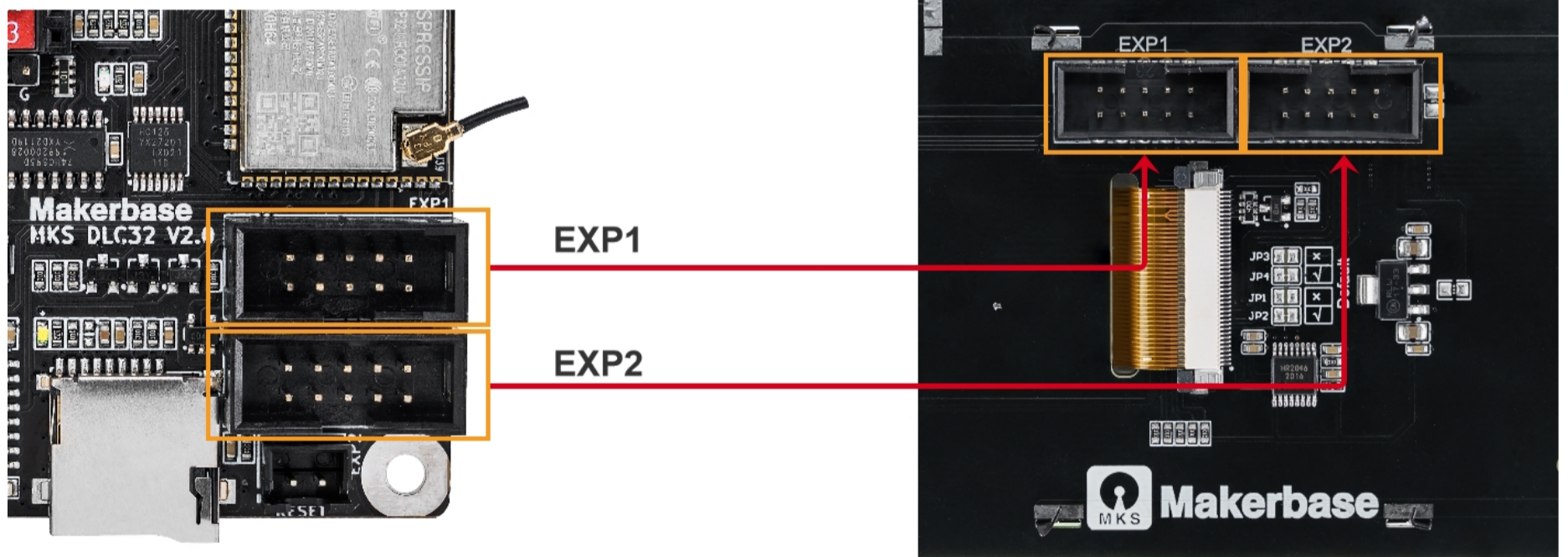

Note:

1. During the connection process, you need to pay attention to the spindle , laser, 12/24v and other interfaces, all of which have a distinction between "+" and "-", so you must pay attention to the wiring process to prevent the positive and negative connections from being reversed, resulting in damage to the motherboard.

2. The motherboard comes with firmware by default, Generally does not need to be updated. If there is no display after connecting the TS35-R screen, or if the screen is blank, it means that the motherboard firmware has been externally erased. You can refer to the second part of firmware update and update the firmware again. Or you can consult our amazon customer service or get technical support by email.

3. Any wiring or adjustment operation, please do it when the power is off.

If you need information such as the schematic diagram of MKS DLC32, you can download it from this website :

<https://github.com/makerbase-mks/MKS-DLC32>

MKS DLC32 update firmware

1.Download DLC32 FIRMWARE

You can go to our MKS github to download :

<https://github.com/makerbase-mks/MKS-DLC32/tree/main/firmware>

Download firmware. Download according to the current motherboard situation and machine situation.

Screen Type (TS35/TS24)

Function type (laser/CNC)

Machine mechanism distinction (normal/coroxy),

Motherboard hardware version (1.0/2.0).

Please select the corresponding bin file to download according to your own machine conditions.

2.Software installation

Download and Installation of MKS LASERTOOL

<https://github.com/makerbase-mks/MKS-DLC32/tree/main/firmware/tool>

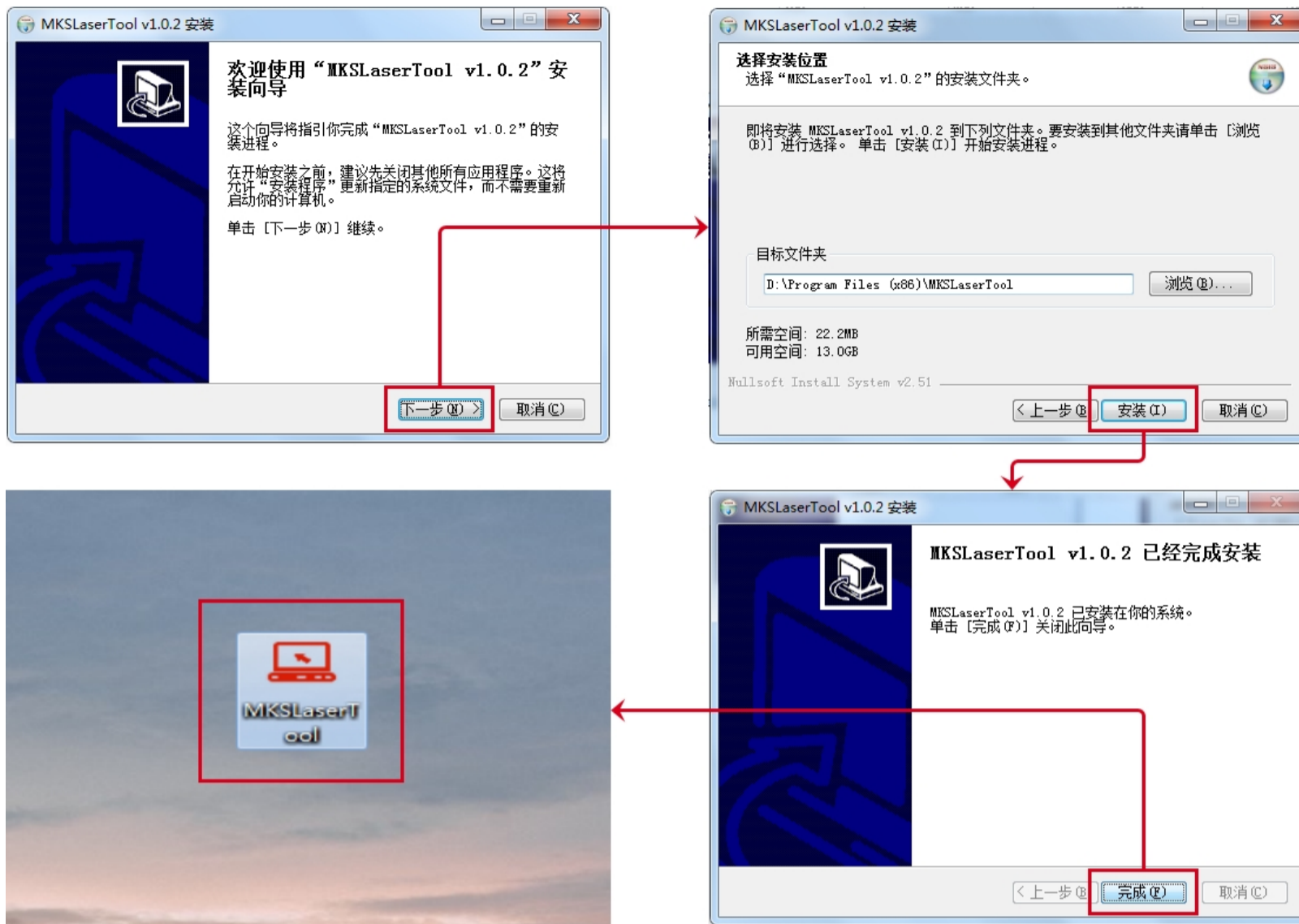

If the DLC32 is connected to the PC for the first time, the USB driver file CH340 needs to be installed to be recognized by the PC.

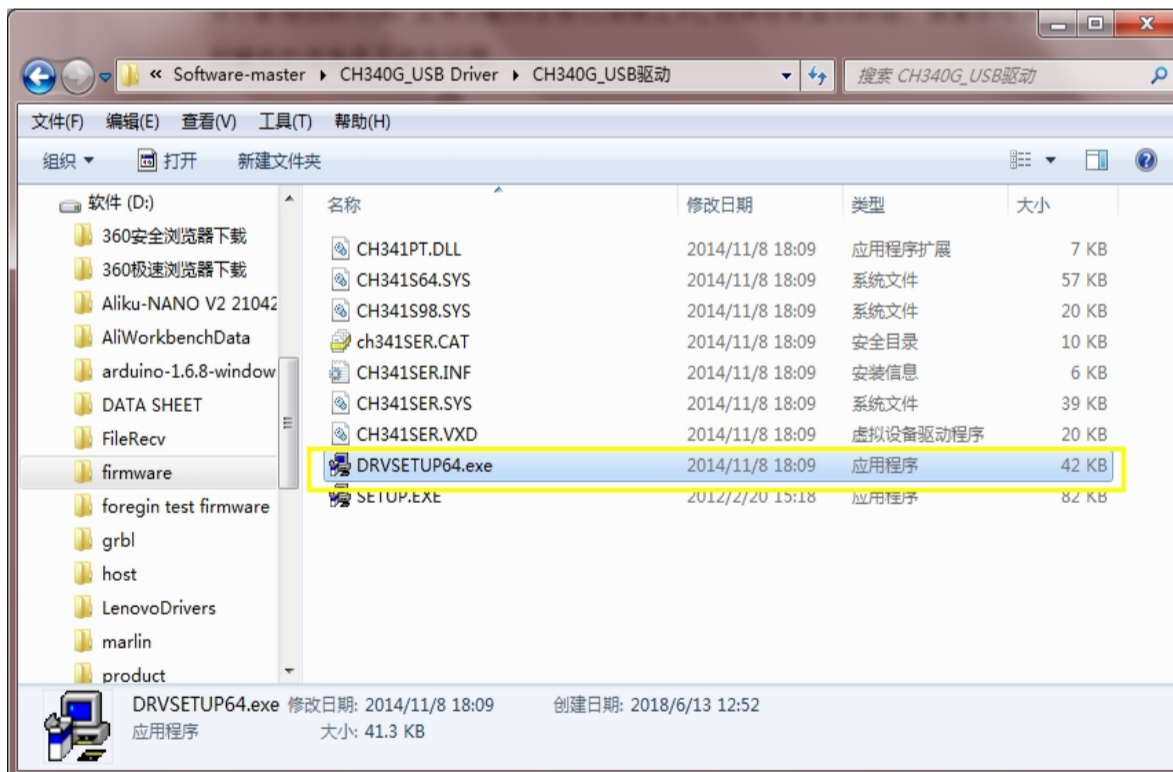

The motherboard needs to be connected to 12-24v for power supply when connecting USB to PC. If the 12-24v power supply is not connected, the motherboard will not recognize it. As shown in the figure below, after the connection, the com is correctly identified.

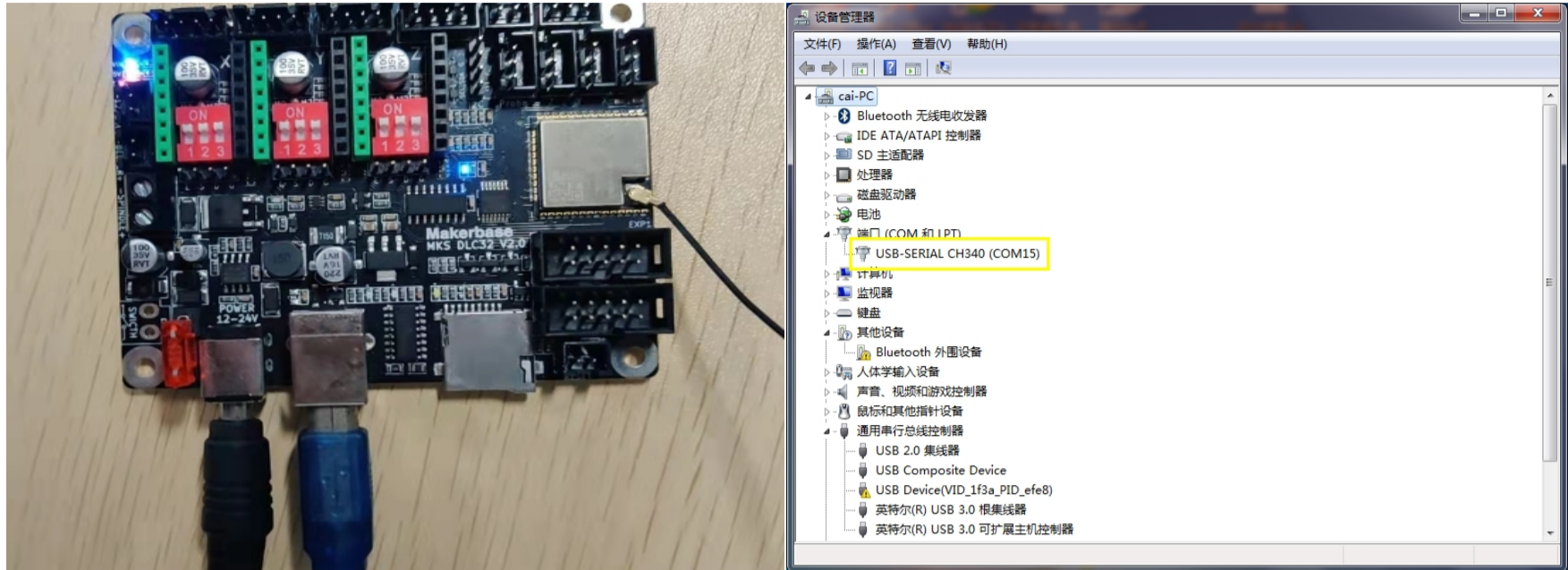

3. Firmware Update Process

Select MKS DLC32 download tool

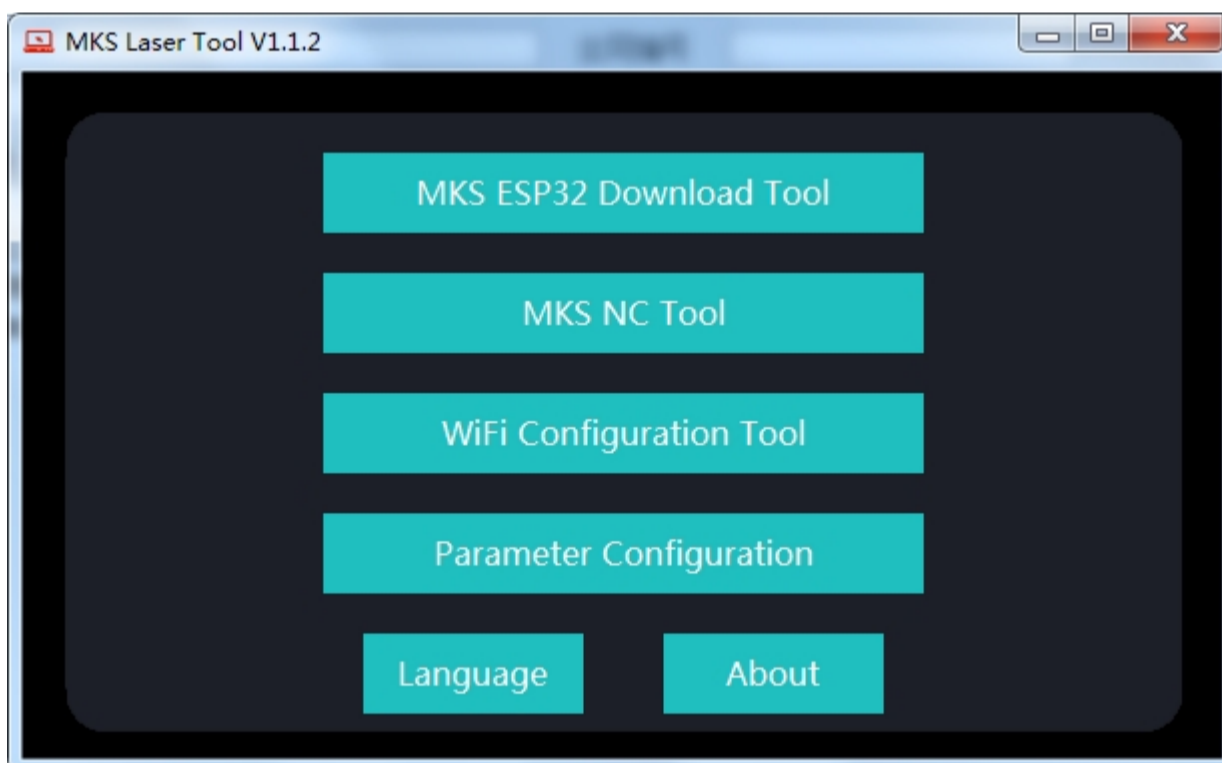

Select firmware file and parameters



SPI SPEED, FLASH SIZE, BAUDRATE parameters are consistent with the picture settings.

COM: Select according to the allocation of the motherboard in the device manager

FILE: Select the required firmware (bin) downloaded from github

After the above parameters are set, click "start" and wait for the firmware update to complete.

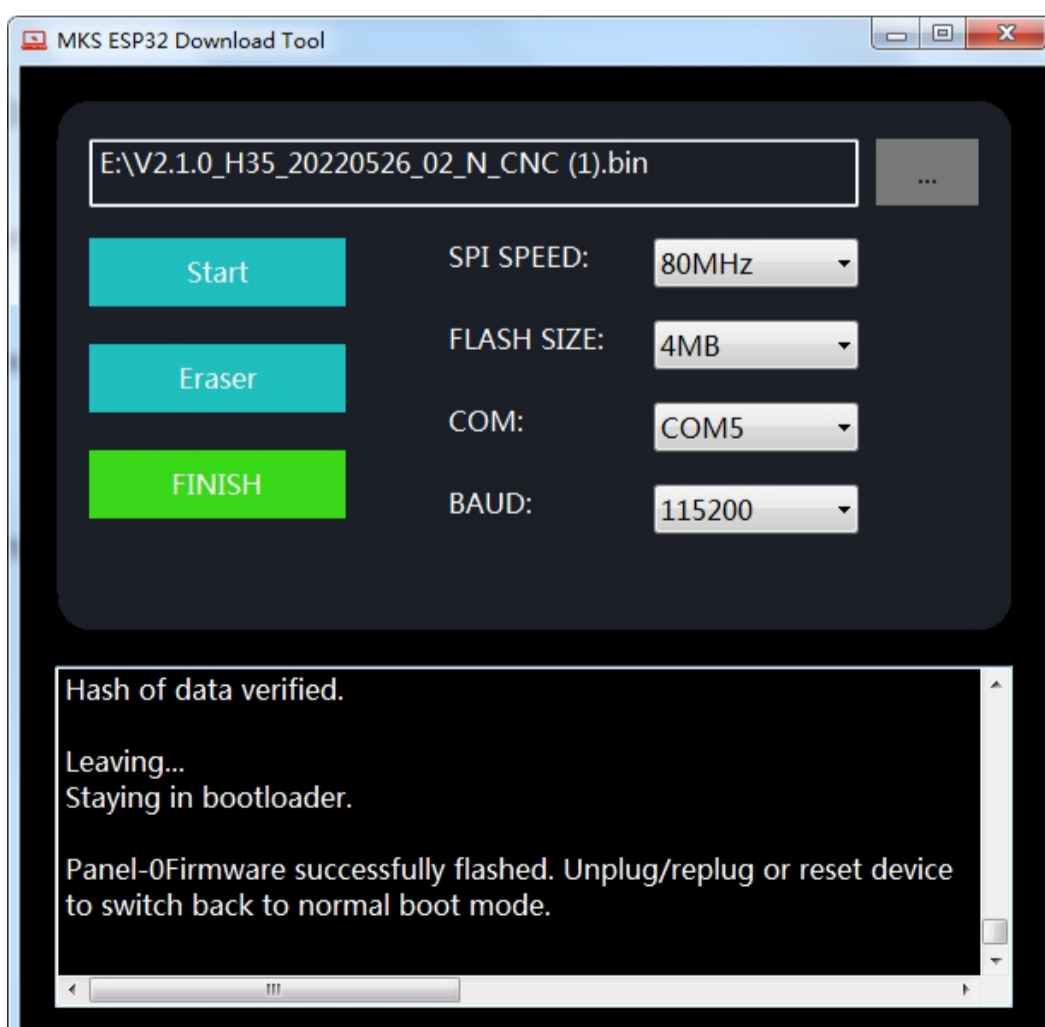

MKS DLC32 control mode

MKS DLC32 can be controlled in these ways

1. TS24/TS35. Direct control from the screen

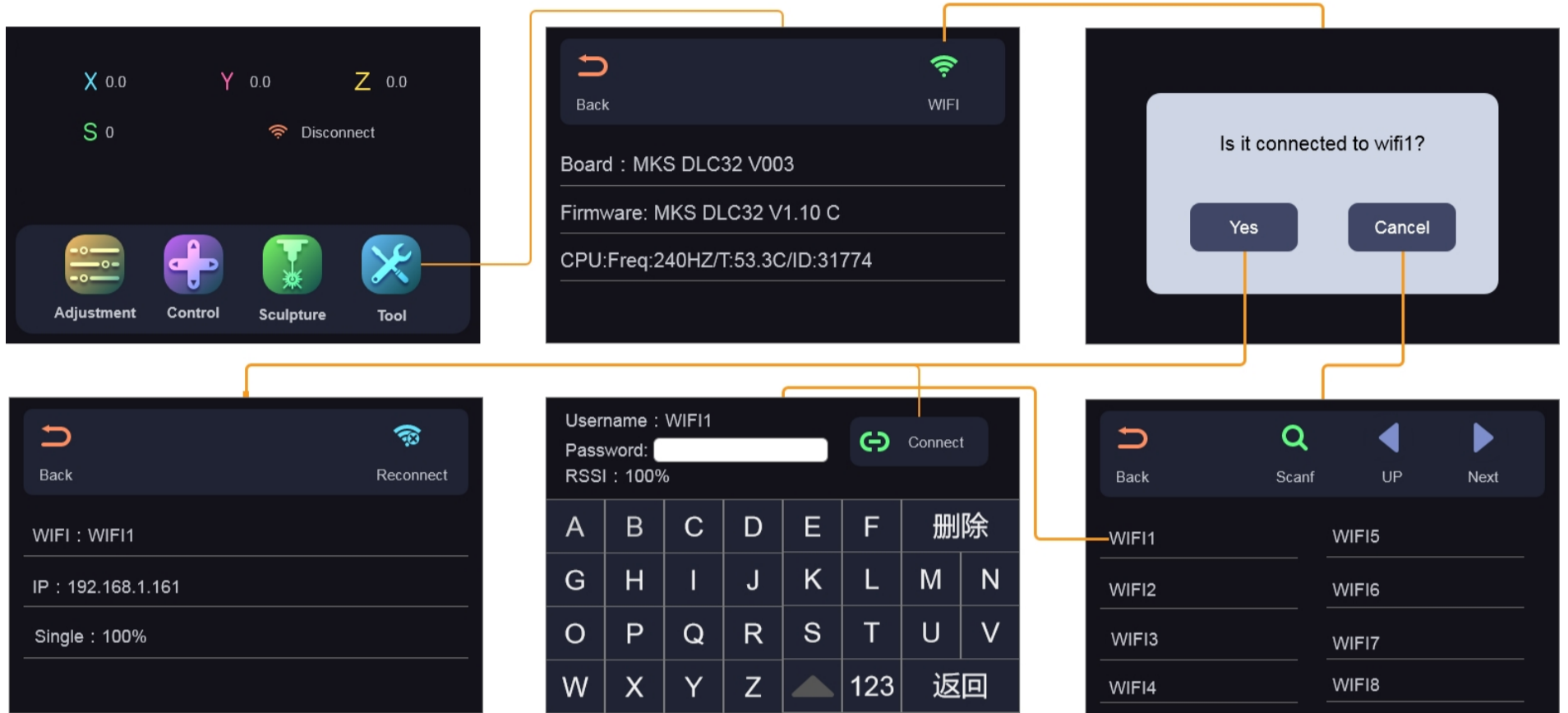

2. PC Host computer software control

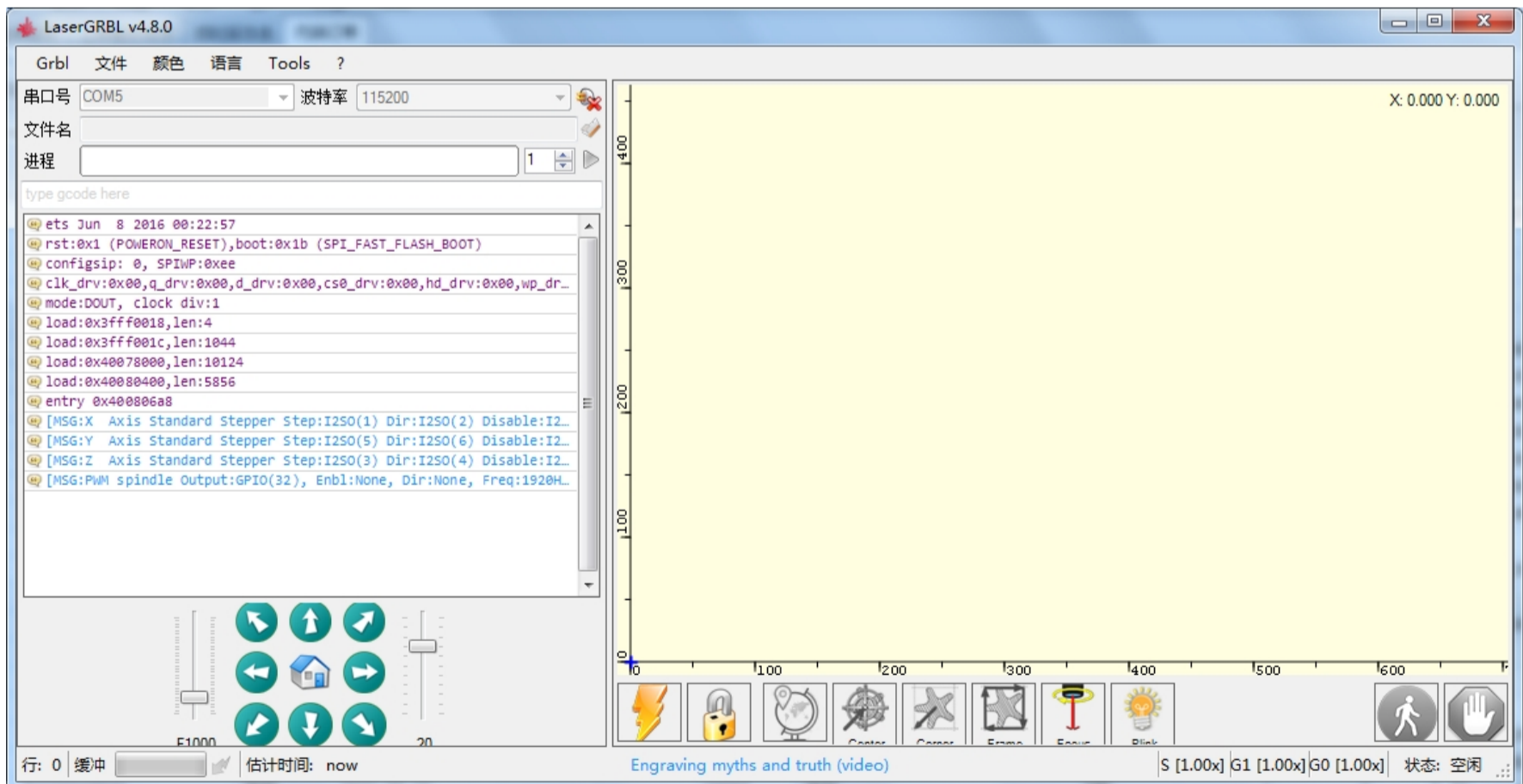

3. Web control

The motherboard needs to be connected to the local network. The IP of DLC32 will be displayed on the screen,

Enter the IP of the motherboard in the browser to enter this interface



4. APP Control

The APP can be downloaded directly from the Google App Store. The usage method is similar to the web control, and the connection is made by entering the IP of the DLC32 motherboard.(The mobile phone and the DLC32 motherboard must be on the same network to connect successfully)

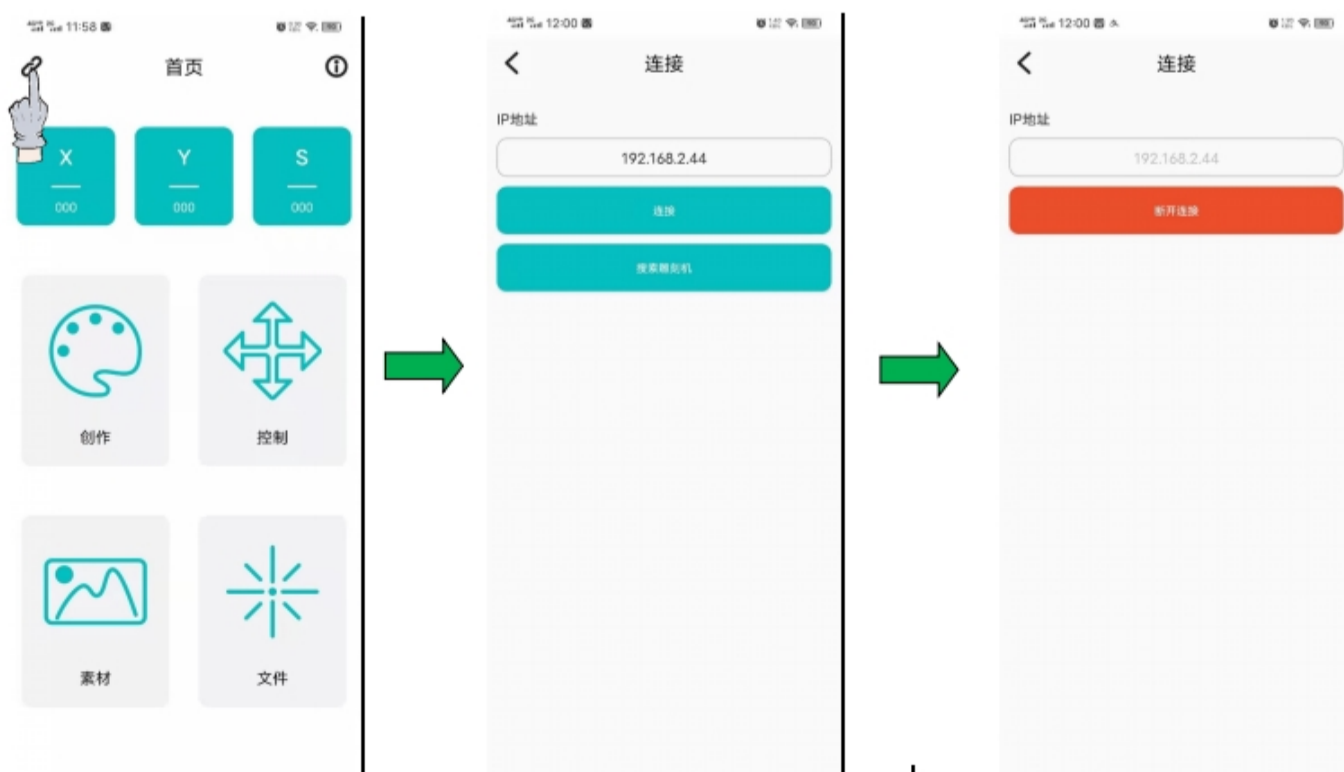

Q&A of MKS DLC32

Q1: Why is there no power supply to the motherboard and the screen after connecting the usb cable.

A1: DLC32 motherboard communication and power supply are separate. Whether it is updating the firmware or controlling the motherboard, it must be powered by 12-24v, the usb interface is not powered.

Q2: Why is the screen display incomplete or blurry?

A2: The motherboard update firmware does not match. Such as hardware version, or screen type. Just select the correct firmware and re-update to restore.

Q3: Why can't the web control or app control connect to the motherboard?

A3: Check whether the DLC32 and the PC (or mobile phone) are on the same network.

Only the same network can control

Q4: How to use air assist

A4: PINs (SCL) and (gnd) on the motherboard can be used for air assist.

Note: The main board output is a control signal (3.3v)

Q5: What if my question is not covered in this one?

A5: You can contact us directly through Amazon.

Or send questions to our email, or leave a message on our github

Email: makerbase123@126.com

Github: <https://github.com/makerbase-mks>