

nutricook®

AIR FRYER 2



User guide.

Please make sure to read this User Guide prior to using your unit.



Find delicious recipes online at:
nutricookworld.com   [nutricookworld](https://www.instagram.com/nutricookworld)

Contents.

- 05** Welcome.
- 07** Before you begin.
- 09** Important safeguards & cautionary information.
- 14** What's included.
 - 15** Air fryer parts overview.
- 17** Getting started.
 - 18** Control panel details.
 - 20** Initial set up.
 - 21** Initial test run.
- 22** Preheating.
- 23** Preset programs.
 - 25** SmartTemp technology.
- 26** Manual program.
- 27** Shaking food.
- 28** Smart features.
- 29** Smart tips.
- 30** Air frying chart.
- 32** Care & maintenance.
- 34** Troubleshooting.
- 35** Warranty.



Welcome to team nutricook®

**Life is complicated. Eating
healthy doesn't have to be.**

Meet the nutricook® Air Fryer 2. It's got everything you know and love about the original nutricook® Air Fryer, plus our exclusive SmartTemp Technology, more functionality, and a Shake reminder so you can make even more delicious healthy creations of your favourite fried food.

There's really no easier way to make simple, healthy meals, snacks and treats you actually want to eat than with this Air Fryer 2.

We are constantly working to create recipes that are **EASY. DELICIOUS. NUTRITIOUS.** You can find these recipes online at nutricookworld.com. We can't wait to see how you make the Air Fryer 2 part of your everyday.

Get social with us.

  [nutricookworld](https://nutricookworld.com)



Find delicious recipes online at:
nutricookworld.com   [nutricookworld](https://www.instagram.com/nutricookworld)

Before you begin.

- Remove all packaging materials from in and around the air fryer and verify that all parts are accounted for.
- Place the air fryer on a stable, level surface, away from external heat sources.
- Read all Important safeguards and cautionary information in this User guide. Failure to do so may result in property damage and/or personal injury.
- Follow Care & maintenance instructions in this User guide to clean the air fryer before cooking.
- Do not remove rating label.



***CAUTION: NEVER** use the air fryer on a stovetop. Do not place appliance on or in close proximity to a hot gas or electric burner, or a heated oven; heat from an external source will damage appliance.



Find delicious recipes online at:
nutricookworld.com   [nutricookworld](https://www.instagram.com/nutricookworld)

Important safeguards & cautionary information.

 **Warning!** This appliance generates heat and escaping steam during use. To avoid the risk of serious injury, carefully read all instructions before operating this appliance.

When using any electrical appliance, basic safety precautions should always be observed, including the following [critical information](#).

GENERAL SAFETY

- DO NOT touch hot surfaces. Use handles or knobs. Use oven mitts or potholders.
- To protect against electrical shock, do not immerse cord, plugs, or the unit in water or other liquid.
- Close supervision is necessary when any unit is used by or near children.
- This appliance is not a toy, and children should not play with it.
- Children should be supervised to ensure that they do not play with the appliance.
- This appliance is not intended for use by persons (including children) with reduced physical, sensory or mental capabilities, or lack of experience and knowledge, unless they have been given supervision or instruction concerning use of the appliance by a person responsible for their safety.
- Unplug from outlet when not in use, during assembly, during disassembly, and before cleaning. Allow to cool before putting or taking off parts and before cleaning.
- Do not use appliance other than its intended use. For household use only.

 ***WARNING:** Read this User guide carefully and completely, and retain for future reference. Failure to adhere to safety instructions may result in serious injury.

- Do not place on or near a hot gas, electric burner and or in a heated oven.
- ⚠ **CAUTION!** Extreme caution must be used when moving unit containing hot oil or other hot liquids.
- Never put the appliance against the wall or other appliances. There should be at least 3 inches of free space for the back side. Left/right sides and the upper side of the appliance. Do not place anything on top of appliance.
- This appliance is not intended to be operated by means of an external timer or separate remote-control system.
- To turn the unit off, press **POWER** ⏻ then remove plug from the wall outlet.
- ⚠ **CAUTION!** During air frying, hot steam is released from the air outlet opening. Keep your hands and face distance from the steam and from the air outlet opening. Also, be careful of hot steam and air when you remove the Air Fryer Basket from the appliance.
- Make sure the air fryer basket is locked into the front of basket drawer – both air fryer basket handle tabs must be fully inserted into the notches on the top of the basket drawer.
- Always make sure basket drawer is fully closed, with air fryer basket handle locked securely in the basket drawer, while Air Fryer is in operation.
- ⚠ **WARNING!** Air Fryer will not operate unless air fryer basket and basket drawer is fully closed.
- ⚠ **CAUTION!** After hot air frying, the air fryer basket and the basket drawer and the cooked foods are hot. Extreme caution must be used when handling the air fryer basket/drawer.

- **⚠ CAUTION!**  **HOT SURFACE:** This appliance generates heat and escaping steam during use. Proper precautions must be taken to prevent the risk of burns, fires or other injury to persons or damage to property.
- **⚠ CAUTION!** This appliance is hot during operation and retains heat for some time after turning OFF. Always use oven mitts when handling hot materials and allow metal parts to cool before cleaning. Do not place anything on top of the appliance while it is operating or while it is hot.
- All users of this appliance must read and understand this instruction manual before operating or cleaning this appliance. Failure to follow any of the important safeguards and instructions for safe use is a misuse of your appliance that can void your warranty and create the risk of serious injury.
- If this appliance begins to malfunction during use, immediately pull the air fryer basket and basket drawer out of the body. Then remove plug from wall outlet. DO NOT use or attempt to repair the malfunctioning appliance.
- DO NOT leave this appliance unattended during use.
- Keep the cord out of reach from children and infants to avoid the risk of electric shock and choking.
- Place the Air Fryer on a stable, level, clean, heat-resistant and dry surface.
- DO NOT replace the empty basket drawer (without the air fryer basket) into the Air Fryer body. Check to make sure the air fryer basket is locked in position in the basket drawer.
 - **⚠ WARNING!** After air frying, make sure to place the basket drawer on a stable, level, clean, heat-resistant and dry surface before pressing the basket release button.
 - **⚠ WARNING!** Under- or over-filling the air fryer basket may damage the Air Fryer and could result in serious personal injury.
- Never move a hot Air Fryer or an Air Fryer containing hot food. Allow to cool before moving.
 - **⚠ WARNING!** This Air Fryer should not be used to boil water.
 - **⚠ WARNING!** This Air Fryer should never be used to deep fry foods.

ELECTRICAL SAFETY

⚠ **CAUTION:** To avoid risk of electric shock, never immerse the cord, plug, or air fryer base in water or other liquids.

- DO NOT use this product in locations with different electrical specifications or plug types. Do not operate with any type of plug adapter or voltage converter device, as these may cause electrical shorting, fire, electric shock, personal injury or product damage.
- DO NOT modify the plug in any way, as doing so will void the warranty.
- DO NOT pull, twist or mistreat the power cord.
- The use of attachments or parts not recommended and sold by the manufacturer may cause fire, electric shock, personal injury, or product damage and will void the warranty.
- If the supply cord is damaged, it must be replaced by its service agent or similarly qualified persons in order to avoid a hazard.
- Always POWER OFF and UNPLUG the appliance when it is not in use or BEFORE cleaning.
- DO NOT allow the cord to hang over the edge of the table or counter. Do not pull, twist, or damage the power cord. Do not allow cord to touch hot surfaces, including the stove.
- DO NOT let cord hang over edge of table or counter, or touch hot surfaces. The cord can get tangled or cause the appliance to fall. Bring it to a qualified technician for examination, repair or electrical and mechanical adjustment.
- DO NOT operate this appliance with a damaged cord or plug or if the appliance malfunctions, or is dropped or damaged in any manner.
- Use of adapters and converters is considered an unauthorized modification of the product and as such voids the warranty. Use of this product in locations with different electrical specifications may result in damage to the product.

ELECTRICAL INFORMATION:

For safety reasons, the cord length of this appliance was selected to reduce Safety Hazards that may occur with a long cord. Extension cords are available and may be used if care is exercised in their use. If an extension cord is used: (1) the marked electrical rating of the extension cord should be at least as great as the electrical rating of the appliance, and (2) the longer cord should be arranged so that it does not drape over the counter or table top where it could be accidentally pulled off the counter or table or tripped over.

PLASTICIZER WARNING

ⓘ **CAUTION:** To prevent Plasticizers from migrating from the finish of the counter top or table top or other furniture, place **NON-PLASTIC** coasters or place mats between the appliance and the finish of the counter top or tabletop. Failure to do so may cause the finish to darken; permanent blemishes may occur or stains can appear.

Save these instructions!
FOR HOUSEHOLD USE ONLY



What's included.

AIR FRYER BASE

AIR FRYER BASKET

AIR FRYER BASKET DRAWER

USER GUIDE

Product Specification:

MODEL	CAPACITY	POWER	VOLTAGE	WEIGHT	DIMENSION
AIR FRYER 2 AF204	3.6 L	1500 watts	220-240 V 50/60 Hz	4.8 kg	27.5x33.6x31.4 cm
AIR FRYER 2 AF205	5.5 L	1700 watts	220-240 V 50/60 Hz	5.9 kg	31.4x38x32.6 cm
AIR FRYER 2 (BLACK) AF205	5.5 L	1700 watts	220-240 V 50/60 Hz	5.9 kg	31.4x38x32.6 cm

Air fryer parts overview.

figure 1.

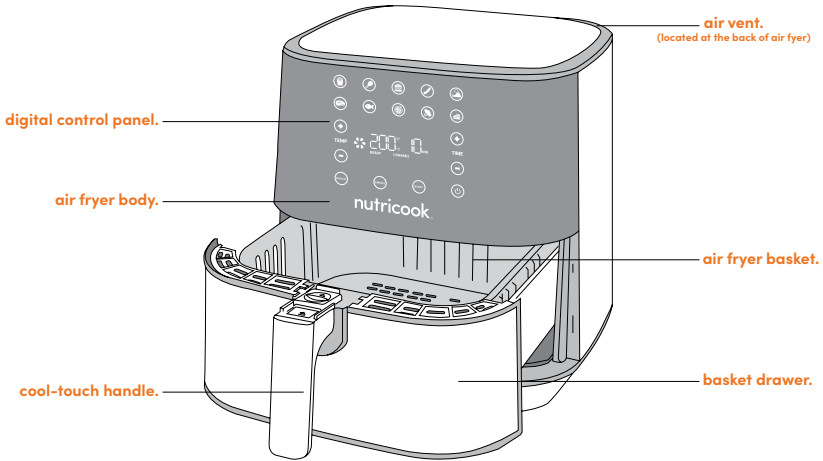
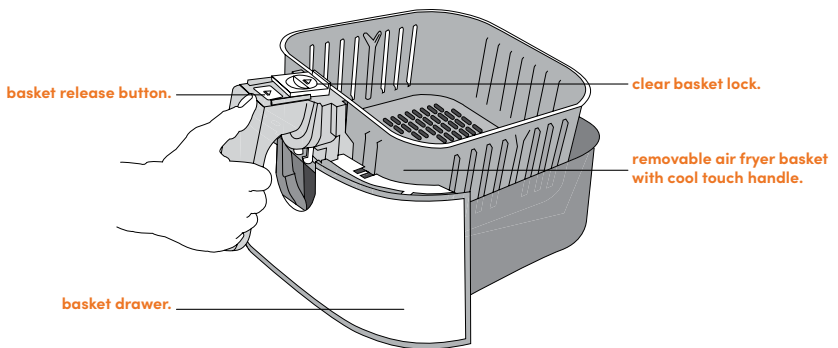



figure 1a - basket parts.



***NOTE:** Images are for visual representations only. Always refer to actual product.



Find delicious recipes online at:
nutricookworld.com   [nutricookworld](https://www.nutricookworld.com)

**Getting
started.**

5 Preset cooking programs.

Preset cooking programs have automatic temperature and time settings (see **Preset Programs Table** for the default time and temperature). Select any of the following cooking program by pressing the icon. The selected program blinks/ flashes and becomes steady if the **START** or **CANCEL** button is pressed.

Fries	Steak
Chicken	Fish
Burger	Pizza
Sausage	Broccoli
Samosa	Cake

6 Temperature control.

Use **+** for increasing temperature value.
Use **-** for decreasing temperature value.

Press and hold both **+** and **-** simultaneously to switch temperature unit from **°C** to **°F** (and vice versa).

7 Time control.

Use **+** for increasing time value.
Use **-** for decreasing time value.

8 Preheat button.

Use to preheat the Air Fryer before cooking to save time and improves the texture of the food.

9 Air frying indicator.

Blinks when the air fryer is cooking.

10 Ready indicator.

Displayed when preheating is completed. This indicates that Air Fryer is ready for cooking.

11 Cancel button.

Use to cancel a program at any time (during program selection or during cooking cycle).

Pressing this button will return the unit display to default temperature and time.

12 Shake reminder.

Blinks halfway through cooking time of some preset cooking program as a reminder to shake or flip food.

13 Start button.

Use to Start cooking. Remains illuminated until unit is Off.

14 Power button.

Use to turn the unit **ON/OFF**.

Initial set up.

1. Remove and safely discard all packaging materials and labels from inside and outside of the Air Fryer. Ensure that there is no packaging underneath and around the Air Fryer basket and basket drawer.
2. Place the Air Fryer on a stable, level, clean, heat-resistant and dry surface. Ensure there is enough space of 13 cm behind and above the Air Fryer against the surface. Leave enough room to remove the Air Fryer basket safely.
3. The Air Fryer is shipped with the Air Fryer basket locked into the basket drawer, inside the Air Fryer body. Firmly grasp the Air Fryer basket handle, slide the clear basket lock on top of the handle forward and pull the basket drawer out; place on a stable, level, clean and dry surface.
4. To unlock and remove the Air Fryer basket from basket drawer, slide the clear basket lock on top of the handle forward to expose the basket release button. Press the basket release button with your thumb and lift the Air Fryer basket up and out of the basket drawer.
5. Wash both the Air Fryer basket and the basket drawer using either a dishwasher or a non-abrasive sponge. Rinse and dry thoroughly before using.
6. Wipe the inside and outside of the Air Fryer with a slightly moist cloth and dry with a towel.
7. Lock Air Fryer basket to the basket drawer. There are two tabs on each side of the handle. Slide the two handle tabs into the notches on top of the basket drawer. An audible click will sound as the Air Fryer basket handle locks securely into place.





NOTE:

- Slide the clear basket lock back over the basket release button to prevent accidental Air Fryer basket release.
 - **DO NOT** press the basket release button while carrying the Air Fryer basket as this will cause the basket drawer to drop causing damage.
8. Put the assembled Air Fryer basket and basket drawer to the Air Fryer.

Initial test run.











This step is optional but recommended in order to get yourself familiarized with the Air Fryer. It will also help eliminate any residue or traces of odor in the Air Fryer that may remain after shipping.

NOTE: This process must be done with no food in the Air Fryer basket.

1. Place the Air Fryer on a stable, level, clean, heat-resistant and dry surface, close to an electrical outlet.
2. Ensure that Air Fryer basket and basket drawer is locked into the Air Fryer body. Plug in unit to a power outlet.
NOTE: All icons will flash and then go off. Only **POWER**  is illuminated.
3. Press **POWER**  to turn the Air Fryer on. All icons will be illuminated. Screen displays **TEMP: 200 °C** and **TIME: 10 minutes**.
NOTE: If no program is selected, Air Fryer will remain in standby mode. After 3 minutes of inactivity, Air Fryer will automatically switch off with only the **POWER**  button illuminated.
4. Press  under **TIME** to adjust time to **5 minutes**.
5. Press **START**  to begin **INITIAL TEST RUN**.
NOTE: No cooking programs will be displayed.
6. Once the time reaches **00**, display shows **End**.

Preheating.











Preheating the Air Fryer before placing food is recommended, unless the unit is already hot from a previous cooking cycle. Preheating saves cooking time and improves the texture of cooked foods.

1. Place Air Fryer on a stable, level, clean, heat-resistant and dry surface, close to an electrical outlet.
2. Ensure that Air Fryer basket and basket drawer is locked into the Air Fryer body. Plug in unit to a power outlet.
NOTE: All icons will flash then go off. Only **POWER**  is illuminated.
3. Press **POWER**  to turn the Air Fryer on. All icons will be illuminated. Screen displays **TEMP: 200 °C** and **TIME: 10 minutes**.
Note: If no program is selected, Air Fryer will remain in standby mode. After 3 minutes of inactivity, the Air Fryer will automatically switch off with only the **POWER**  illuminated.
4. Press **PREHEAT** . Icon blinks and displays the default **TEMP: 200 °C** and **TIME: 03 minutes**.
5. Optionally, adjust **PREHEAT**  temperature and time using either  or .
6. If you wish to change the temperature unit from **°C** to **°F** (and vice versa), press and hold  and  of **TEMP** simultaneously until Air Fryer beeps and either **°C** or **°F** is illuminated.
7. Press **START**  to begin **PREHEATING**.
NOTE: Once **PREHEATING** has started, **PREHEAT**  icon becomes steady and all the cooking programs are off.
8. Once **PREHEATING** is done, Air Fryer beeps 5 times and screen displays **READY**. The temperature set blinks and time field shows **--**. All icons in the control panel are illuminated.

Preset programs.

These programs are designed with pre-programmed time and temperature for certain foods to take the guess work out of cooking.

Preset programs table.

Preset icon	Description	DEFAULT			SMART TEMP*			Shake Reminder Function
		Temperature °C	Temperature °F	Time (min)	Temperature °C	Temperature °F	Time (min)	
	Fries	180	355	14	180	355	7	((SHAKE))
					200	390	7	
	Chicken	190	375	25	-	-	-	((SHAKE))
	Burger	200	390	20	-	-	-	((SHAKE))
	Sausage	180	355	14	-	-	-	((SHAKE))
	Samosa	180	355	12	180	355	6	((SHAKE))
					200	390	6	
	Steak	200	390	6	-	-	-	-
	Fish	180	355	8	-	-	-	-
	Pizza	160	320	12	-	-	-	-
	Broccoli	150	300	8	-	-	-	((SHAKE))
	Cake	150	300	30	-	-	-	-

*See **SmartTemp** section of this User Guide for additional details.

1. **PREHEAT** your Air Fryer. Follow steps in **PREHEATING**.
2. When Air Fryer displays **READY**, add food to the Air Fryer basket and lock it in.
3. Select a preset program.
4. The selected program will blink indicating that it is active. Screen displays default temperature and time (see **Preset Programs Table**).

5. Optionally, adjust the temperature and time settings, as desired.
NOTE: Adjustments can be made during program selection or even during the cooking process.
 - Press either **+** or **-** of **TEMP** or **TIME** to adjust the temperature and time values.
Time range: 1-60 minutes
Temperature range: 75 – 200°C/165 – 390°F
 - Optionally, press and hold **+** and **-** of **TEMP** simultaneously to switch between **°C** to **°F (and vice versa)**.
6. Press **START**  to begin cooking.
NOTE: The selected cooking program becomes steady and all other icons go off.
7. When using some **Preset Programs**, the automatic **SHAKE** reminder function is activated halfway through cooking and **(SHAKE)** appears on the display (see **Preset Programs Table**). The Air Fryer will beep **5 times** while **(SHAKE)** blinks on the display. **(SHAKE)** will continuously blink until the Air Fryer basket is opened.

How to Shake:

- Pull the Air Fryer basket and basket drawer from the unit. As a safety feature, the Air Fryer automatically pauses the cooking cycle and display will go off once the Air Fryer basket and basket drawer are pulled out from the unit.
- ⚠ WARNING! Be careful of hot steam.**
- **SHAKE** or flip food carefully. While shaking or flipping food, ensure not to press the basket release button otherwise, Air Fryer basket drawer will drop causing damage.
 - Ensure to shake or flip food no longer than **30 seconds** to prevent the Air Fryer from cooling down.
 - Place the Air Fryer basket back and lock it in. Cooking resumes with the remaining cooking time.

See **SHAKING FOOD section of this User Guide for additional details.*

8. Once cooking time is finished, Air Fryer displays **End** and beeps 3 times. All the icons are illuminated.
9. Pull the Air Fryer basket and basket drawer from the unit and place on a clean, flat surface.
⚠ WARNING! Be careful of hot steam.
10. Press the basket release button and remove the Air Fryer basket from the basket drawer to serve food.

NOTE:

- While separating the Air Fryer basket from the basket drawer, always ensure that it is placed on a flat and heat-resistant surface.
 - Any excess fats or oil collected on the basket drawer must be drained before replacing the Air Fryer basket.
11. Allow the Air Fryer basket and basket drawer to completely cool before cleaning.

SmartTemp for Fries and Samosa.

The **FRIES** and **SAMOSAS** programs have our breakthrough **SmartTemp Technology** that automatically adjusts the temperature halfway through the cooking program. Both programs have a preset temperature of **180°C/355°F** for the first half of the cooking time that automatically changes to **200°C/390°F** for the remaining half of the cooking time.

Our unique **SmartTemp Technology** cooks fries/samosa at a lower temperature of **180°C/355°F** for the first half of the cooking time which allows the food to be cooked tenderly on the inside. For the second half of the cooking time, the temperature automatically increases to **200°C/390°F** which makes your fries/samosa super crispy on the outside.

Manual Program.

This program allows you to cook manually without selecting any Preset.

1. **PREHEAT** your Air Fryer. Follow steps in **PREHEATING**.
 2. When Air Fryer displays **READY**, add food to the Air Fryer basket and lock it in.
 3. Set the temperature and time.
 4. Optionally, adjust the temperature and time settings, as desired.
NOTE: Adjustments can be made during program selection or even during the cooking process.
 - Press either **+** or **-** of **TEMP** or **TIME** to adjust the temperature and time values.
Time range: 1-60 minutes
Temperature range: 75 – 200°C/165 – 390°F
 - Optionally, press and hold **+** and **-** of **TEMP** simultaneously to switch between **°C** to **°F (and vice versa)**.
 5. Press **START**  to begin cooking.
NOTE:
 - When using **Manual Program**, the **SHAKE** reminder function will not be activated. Regardless, you should still shake or flip your food, as applicable. Follow steps on **How to Shake Food**.
- *See **SHAKING FOOD** section of this User Guide for additional details.*
6. Once cooking time is finished, Air Fryer displays **End** and beeps 3 times. All the icons are illuminated.
 7. Pull the Air Fryer basket and basket drawer from the unit and place on a clean, flat surface.
⚠ WARNING! Be careful of hot steam.
 8. Press the basket release button and remove the Air Fryer basket from the basket drawer to serve food.
NOTE:
 - While separating the Air Fryer basket from the basket drawer, always ensure that it is placed on a flat and heat-resistant surface.
 - Any excess fats or oils collected on the basket drawer must be drained before replacing the Air Fryer basket.
 9. Allow the Air Fryer basket and basket drawer to completely cool before cleaning.

Shaking Food.

During the cooking process, shake or flip your food for even cooking and browning. Some presets feature an automatic **SHAKE** Reminder function halfway through cooking. It is recommended to shake or flip your food once or more, if desired.

⚠ **CAUTION:**

- Always be careful of hot steam when pulling the Air Fryer basket and basket drawer from the Air Fryer.
- **NEVER** press the basket release button when holding the Air Fryer basket handle.

1. Hold the Air Fryer basket handle just above a heat resistant surface and shake or flip food carefully.
2. While shaking or flipping food, ensure not to press the basket release button otherwise, Air Fryer basket drawer will drop causing damage.
3. Depending on the food, the basket might be too heavy to shake. In this case, ensure to place the Air Fryer basket and the basket drawer on a stable and heat-resistant surface. Press the basket release button and separate the Air Fryer basket from the basket drawer. Shake or flip food carefully.

⚠ **WARNING!**

- Ensure there is no oil dripping from the Air Fryer basket. Excess oil may splatter while shaking the food and can cause serious injury especially when hot.
4. If food won't shake or can't be flipped because of the weight, use a tong instead.

⚠ **WARNING!**

- For safety purposes, it is recommended to use tongs to shake or flip food that contains oil or any hot liquids. Any excess oil and liquids can splash from the basket when shaking.
- Always drain any excess oil or hot liquids from the basket drawer. Excess oil may produce extra smoke when heated for longer period.

Smart features.

Temperature unit conversion.

Press and hold **TEMP**'s **+** and **-** buttons simultaneously for **3 seconds** until Air Fryer beeps and temperature unit changes from **°C** to **°F**. Do the same step to switch back temperature unit from **°F** to **°C**.

Shake reminder function.

The Air Fryer features an automatic **SHAKE** reminder function for some presets that is activated halfway through the cooking time. This feature will alert you with 5 audible beeps and **(SHAKE)** will continuously blink on the display until Air Fryer basket and basket drawer is opened.

Automatic pausing.

The Air Fryer automatically pauses when the Air Fryer basket and basket drawer is pulled out of the unit. As a safety feature, the Air Fryer won't work if the basket is not placed or is not properly locked.

Automatically resumes cooking.

Once the Air Fryer basket and basket drawer has been put back while cooking, the cooking process automatically resumes with the remaining time and current settings.

Overheating protection.

As a safety feature, the Air Fryer automatically turns **OFF** when overheating is detected. Do not use the Air Fryer and allow enough time to cool down completely.

Smart tips.

1. Please consult the **Air Frying Chart** and/or follow package instructions for suggested cooking time and temperature.
2. Always pat food dry before cooking to encourage browning and avoid excess smoke.
3. Ensure that food will not exceed the **MAX** line on the Air Fryer basket. Overfilling will result to uneven cooking. It is recommended to fry smaller batches of food as this will allow proper air circulation for even cooking and browning.
4. Spray oil works best. Oil is distributed evenly and less oil is needed. Canola, olive, avocado, coconut, grapeseed, peanut or vegetable oil works well. Alternatively, add a small amount of oil (not more than **2 tbsp**).
NOTE: Adding a small amount of oil will make the food crispier.
5. It is recommended to spray or add a small amount of oil to your food if adding seasoning or breading to ensure that these light ingredients sticks to the food. The air fryer rapidly circulates air and pushes it to your food during the cooking process which can take out light ingredients if they are not properly adhered to the food.
6. When cooking naturally high fat foods, it is recommended to empty oil and fats collected on the basket drawer between batches to avoid excess smoke.
7. It is recommended to shake or flip your food once or more, as desired to check for doneness. This will also allow even cooking and browning. Always observe safety precautions when shaking or flipping foods.

Air frying chart.

Includes preset food menu items.

⚠ **WARNING!** Times are estimated and based on average sizes and weights. ALWAYS use a meat thermometer to ensure that the meat, poultry and fish are cooked thoroughly before serving.

NOTE: Frying smaller batches will result in shorter cooking times and higher food quality. Adjust air frying temperatures and times as necessary to suit your taste.

NOTE: Unless food is pre-packaged and pre-oiled, for browned and crispy results, all foods should be lightly oiled before air frying.

FOOD	TEMP	AIR FRY TIME	ACTION
Root Vegetables, 2 - 3 cups fresh (roasted)	190°C	15 - 20 min	toss with oil, shake 3x
Asparagus, 2 - 3 cups, fresh thin stems	190°C	7 - 9 min	spray with oil, shake 2x
Green Beans, Sugar Snap Peas, 2 - 3 cups fresh	190°C	7 - 9 min	spray with oil, shake 1x
Broccoli, 2 - 3 cups fresh (roasted)	190°C	5 - 7 min	spray with oil, shake 3x
Brussels Sprouts, halved, 2 - 3 cups fresh	190°C	8 - 10 min	spray with oil, shake 2x
Butternut Squash, seeded, 1/2 inch chunks, 2 - 3 cups fresh	190°C	15 min	spray with oil, shake 3x
Fennel, fresh, chopped, 2 - 3 cups fresh	190°C	7 - 9 min	spray with oil, shake 2x
Fried Sweet Potato Fries (fresh, hand cut, 1/8 to 1/4-inch thick)	200°C	13 - 15 min	spray with oil, shake 3x

FOOD	TEMP	AIR FRY TIME	ACTION
French Fries, Idaho Potatoes, 2 - 3 cups (fresh, hand cut, 1/4 to 1/3 inch thick) (frozen, 1/4 to 1/3 inch thick)	200°C	12 min 12 min	spray with oil, shake 3x spray with oil, shake 3x
Meat, Roast, Chops	180°C	25 min	rub or spray with oil, add seasoning, turn over test for doneness
Ribeye Steaks, (2) 1 kg, 1 1/2 inch thick, room temp. medium rare medium well done	200°C	Preheat +6 min Preheat +10 min Preheat +14 min	rub or spray with oil, add seasoning, turn over test for doneness, rest 15 minutes - check at 12 minutes
Hamburgers, 0.50-2 kg, rare - well	180°C	Preheat +3 - 6 min	spray with oil, add seasoning, turn over test for doneness
Chicken Wings, 1-1.50 kg (fresh/thawed)	180°C	20 min	spray with oil, shake 2x test for doneness
Chicken Tenders/Fingers, boneless	180°C	18 - 20 min	spray with oil, shake 1x
Chicken Pieces, bone in	180°C	20 - 30 min	spray with oil, turn over test for doneness
Fish Fillet (fresh, thawed, battered)	200°C	10 min	spray with oil, turn over test for doneness
Shrimp (thawed, battered), 0.50-1 kg	160°C	8 min	spray with oil, turn over, shake

Care & maintenance.



! **WARNING:** To avoid electric shock or damage to your air fryer, always unplug the power cord from the power supply outlet before cleaning. Make sure that all parts of your air fryer have cooled down completely.

! **CAUTION:** Do not immerse the power cord or your air fryer in water or any other liquids.

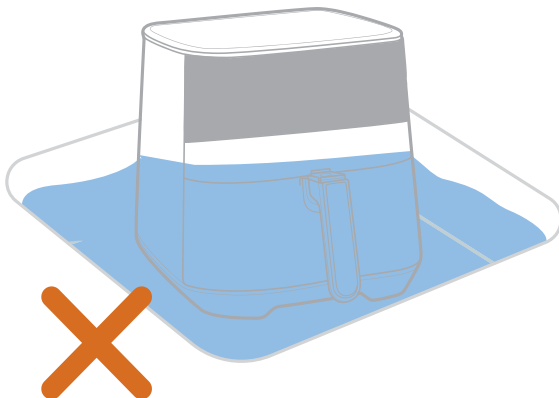

- Do not use abrasive cleaners, steel wool, or scouring pads.
- Dry all parts thoroughly after cleaning, before using, or before storing your air fryer.
- Make sure that all parts and surfaces are completely dry before connecting your air fryer to a power outlet. Wet parts can cause electric shock.



! **WARNING:** DO NOT immerse air fryer base in water.

Part	Cleaning Methods			Cleaning Tip
	Dishwasher Safe	Hand Wash (submerged)	Wipe Clean (damp cloth)	
Air fryer base and plug cord.				<ul style="list-style-type: none"> Wipe the outer part of the air fryer base with soft and barely damp cloth. Wipe the plug cord with dry cloth. Clean the inner part of the air fryer base with soft and barely damp cloth including the heating coil to remove food debris. ⚠ WARNING! Always ensure that the heating coil is dry before using the air fryer.
Air fryer basket and drawer.				<ul style="list-style-type: none"> Wash the air fryer basket and basket drawer with hot, soapy water and non-abrasive sponge. These parts are top rack dishwasher safe. We recommend rinsing them and remove any dried food debris before washing in the dishwasher. NOTE: The air fryer basket and basket drawer have non-stick coating. NEVER use metal utensils and abrasive cleaning materials to avoid damage. IMPORTANT TIP: For stubborn grease, clean the air fryer basket and basket drawer as follows: <ol style="list-style-type: none"> Mix 118 ml of baking soda and a few tablespoons of water (1 tbsp=15 ml) in a small bowl until forming a spreadable paste. Using a soft sponge, spread the paste on the air fryer basket & basket drawer and gently scrub. Leave for about 15 minutes before rinsing. Wash with soft and water before using. NOTE: Always ensure that the air fryer basket and basket drawer are dry before locking in to the air fryer base.

Troubleshooting.

Problem	Possible Cause	Solution
The AIR FRYER does not work	The Air Fryer is not plugged in. The Air Fryer has turned itself OFF	<p>Plug cord into the wall outlet.</p> <p>To begin, press the POWER  button.</p> <p>Make sure the air fryer basket/drawer is assembled correctly and fully inserted into the Air Fryer body.</p> <p>Press the desired cooking program. Press START  to begin cooking.</p>
Food not cooked	The Air fryer Basket is overloaded.	<p>Fry smaller batches of food.</p> <p>Shake foods 2x or 3x during the cooking process.</p> <p>Increase TEMP.</p> <p>Increase air fry TIME.</p>
Food is not fried evenly	The Air fryer Basket is overloaded.	<p>Fry smaller batches of food.</p> <p>Apply a light, even coat of spray oil to food before frying.</p> <p>Shake foods 2x or 3x during the cooking process.</p>
Air fryer basket/drawer won't slide into the Air Fryer body properly	The Air fryer Basket is overloaded.	<p>Fry smaller batches of food.</p> <p>Air Fryer will not turn ON until the air fryer basket/drawer is assembled correctly and fully inserted into the Air Fryer body</p>
White smoke coming from the Air Fryer	<p>The Air Fryer is overloaded with oil.</p> <p>The air fryer basket and basket drawer have not been cleaned.</p>	<p>When frying heavily oily foods, such as bacon, it may be necessary to clean the basket drawer more frequently.</p> <p>Clean air fryer basket and drawer after each use.</p>
Fresh fries are not fried evenly	The Air fryer Basket is overloaded.	<p>Soak, rinse and fully dry potatoes before frying.</p> <p>Use fresh, firm potatoes.</p>
Fries are not crispy	Raw fries have too much water.	<p>Use a clean kitchen towel to wrap and dry potato sticks thoroughly before adding oil.</p> <p>Cut potato sticks smaller.</p> <p>Shake and spray potatoes frequently.</p>

Warranty.

LIMITED WARRANTY FOR NUTRICOOK

Nutricook's limited warranty obligations are confined to the terms set forth below:

Nutricook warrants this product against defects in materials and workmanship for a period of **two years** from the date of original retail purchase. This limited warranty is valid only in the country in which the product is purchased and comes with the product at no extra charge, however shipping and processing fees will be incurred for returns, replacements and or refunds.

OBTAINING WARRANTY SERVICE

For limited warranty service, simply visit www.nutricookworld.com for Customer Service details of your respective territory or contact our customer service department at info@nutricookworld.com and we will be glad to help you. When you contact our customer service department you will be asked for your name, address, telephone number and to provide proof of the original purchase (receipt) containing a description of the product(s), purchase date, and the appropriate Nutricook bar code(s). Before you send your product for limited warranty service please make sure to keep a copy of all relevant documents for your files (receipt, etc.). It is always recommended to purchase product insurance and tracking services when sending your product for service. Remember, shipping and processing fees will be incurred and are not covered by the two-year limited warranty.

EXCLUSIONS AND LIMITATIONS

This **Nutricook Two-Year Limited Warranty** applies only to Nutricook products distributed by or for Nutricook that can be identified by the "Nutricook" trademark, trade name, logo and bar code. **Nutricook's Two-Year Limited Warranty** does not apply to any other products that may appear to be authentic, but were not distributed/sold by Nutricook.

Warranty.

Normal wear and tear is not covered by this limited warranty.

This limited warranty applies to consumer use only, and is void when the product is used in a commercial or institutional setting.

This limited warranty extends only to the original consumer purchaser and is not transferable. In addition, proof of purchase must be demonstrated.

Repair or replacement of the product (or, if repair or replacement is not feasible, a refund of the purchase price) is the exclusive remedy of the consumer under this limited warranty. Nutricook shall not be liable for any incidental or consequential damages for breach of this limited warranty or any implied warranty on this product.

This limited warranty does not apply: (a) to damage caused by accident, abuse, misuse, or misapplication; (b) to damage caused by improper maintenance (including unauthorized parts service); (c) to a product or a part that has been modified in any way; (d) if any Nutricook bar code or trademark has been removed or defaced; and or (e) if the product has been used with an adapter/converter.

THIS LIMITED WARRANTY AND THE REMEDIES SET FORTH ABOVE ARE EXCLUSIVE AND IN LIEU OF ALL OTHER WARRANTIES, REMEDIES AND CONDITIONS, WHETHER ORAL OR WRITTEN, EXPRESS OR IMPLIED. NUTRICOOK SPECIFICALLY DISCLAIMS ANY AND ALL IMPLIED WARRANTIES, INCLUDING, WITHOUT LIMITATION, WARRANTIES OF MERCHANTABILITY AND FITNESS FOR A PARTICULAR PURPOSE. IF NUTRICOOK CANNOT LAWFULLY DISCLAIM IMPLIED WARRANTIES UNDER THIS LIMITED WARRANTY, ALL SUCH WARRANTIES, INCLUDING WARRANTIES OF MERCHANTABILITY AND FITNESS FOR A PARTICULAR PURPOSE ARE LIMITED IN DURATION TO THE DURATION OF THIS LIMITED WARRANTY. No Nutricook reseller, agent, or employee is authorized to make any modification to this warranty.

NUTRICOOK IS NOT RESPONSIBLE FOR DIRECT, SPECIAL, INCIDENTAL OR CONSEQUENTIAL DAMAGES RESULTING FROM ANY BREACH OF WARRANTY OR CONDITION, OR UNDER ANY OTHER LEGAL THEORY, INCLUDING BUT NOT LIMITED TO LOST PROFITS, DOWNTIME, GOODWILL, DAMAGE TO OR REPLACEMENT OF EQUIPMENT AND PROPERTY. NUTRICOOK SPECIFICALLY DOES NOT REPRESENT THAT IT WILL BE ABLE TO REPAIR ANY PRODUCT UNDER THIS LIMITED WARRANTY.

nutricook.

AIR FRYER 2



nutricook. | www.nutricookworld.com | All rights reserved.

Illustrations may differ from the actual product. We are constantly striving to improve our products, therefore the specifications contained herein are subject to change without notice.

NC-IMAF204-5