

Tikom

G8000

Robotic Vacuum Cleaner

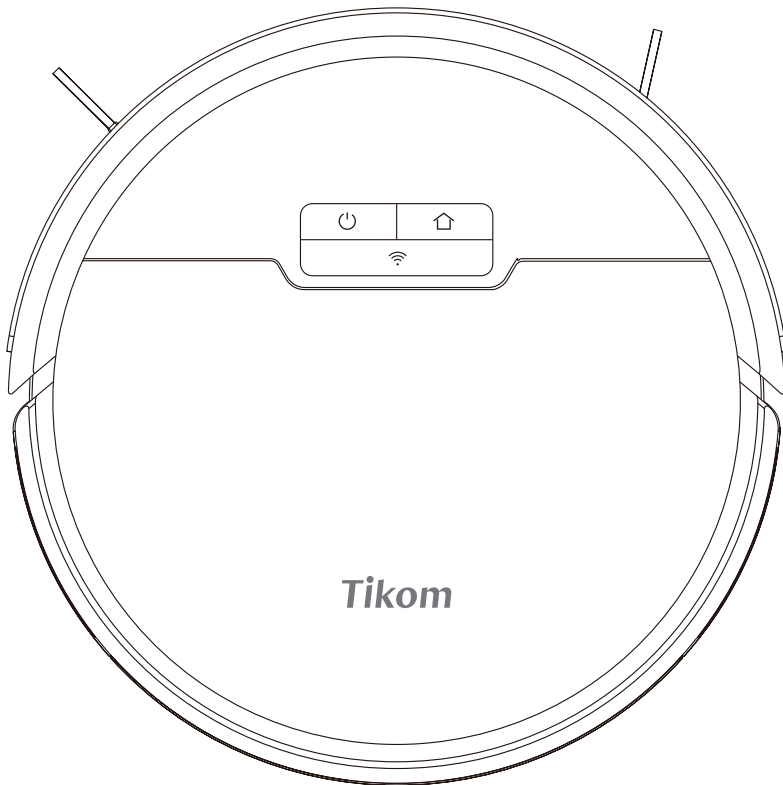

User Manual

Please read all the instructions before using and keep it well for future reference.

CONTENTS

1. Important Safety Instructions	1
2. About Robot	4
2.1 What's in the Box	4
2.2 Robot Anatomy	5
2.2.1 Top View	5
2.2.2 Bottom View	5
2.2.3 Dust Bin	6
2.2.4 Charging Station	6
2.2.5 Mopping Module	6
2.3 LED Indication	7
3. Using Robot	8
3.1 Getting Started	8
3.2 Important Tips Before Usage	10
3.3 Power On/Off Robot	11
3.4 Connect Robot with Wi-Fi	11
3.4.1 app Downloading and Installation	11
3.4.1.1 app Downloading	11
3.4.1.2 app Registration and Login	12
3.4.2 Wi-Fi Connection Requirement	12
3.4.2.1 Mobile Device Requirement	12
3.4.2.2 Robot Requirement	12
3.4.2.3 Wi-Fi Requirement	12
3.4.3 Wi-Fi Status Light	13
3.4.4 Connect with TuyaSmart app	14
3.4.5 TuyaSmart app introduction	15
3.4.6 Work with Amazon Alexa or Google Assistant	16
3.5 Cleaning Mode	18
3.5.1 Smart Cleaning	18
3.5.2 Manual Cleaning	19
3.5.3 Spot Cleaning	19

3.5.4 Edge Cleaning	19
3.5.5 Random Cleaning	20
3.5.6 Carpet Boost	20
3.6 Schedule Cleaning Setup	21
3.7 Sleep Mode	21
3.8 Error	21
3.9 Charging	21
3.10 Boundary Strip Usage	22
3.11 Mopping the Floor	22
3.12 Firmware Update	24
4. Maintenance and Care	25
4.1 Cleaning and Replacement Frequency	25
4.2 Clean Dust Bin and Filter	26
4.3 Clean Main Brush	27
4.4 Clean Side Brush	28
4.5 Clean Sensor and Charging Contacts	28
4.6 Clean Caster Wheel	29
4.7 Water Tank and Mopping Cloth Maintenance	29
5. Troubleshooting	30
5.1 Error & Voice Alarm	30
5.2 Frequently Asked Question	31
5.3 Wi-Fi Connection	35
5.3.1 Wi-Fi Setup Requirement	35
5.3.1.1 Mobile Device Requirement	35
5.3.1.2 Robot Requirement	36
5.3.1.3 Wi-Fi Requirement	36
5.3.2 Wi-Fi Connection troubleshooting	37
6. Specifications	38
7. Customer Service	39

1.Important Safety Instructions

PLEASE READ CAREFULLY BEFORE USE • FOR HOUSEHOLD USE ONLY

To reduce the risk of injury or damage, read these safety instructions carefully and keep them at hand when setting up, using, and maintaining this device.

- This robot could be used by users aged from 8 years and above, but for the persons with reduced physical, sensory or mental capability, or by people who are lack of related experience and knowledge, only if they have received proper supervision or instructions by a professional who knows how to use the robot in a safe way and understand the hazards involved.
- DO NOT let children or your pet play with the robot. Do not allow them to sit or stand on the robot either.
- DO NOT let the robot to clean a room where an infant or child is unattended.
- DO NOT handle any part of the robot with wet hands.
- DO NOT operate the robot on the wet surfaces, or in a bathroom, or near a pool.
- DO NOT spill any water on the robot, or expose it to any moisture, rain or snow.
- DO NOT allow robot to clean anything wet, like paint, chemicals, etc..
- DO NOT utilize the robot to clean flammable or combustible liquids, such as petrol, perfume.
- DO NOT utilize the robot to pick up anything that is burning or smoking, such as cigarettes, matches, or hot ashes, etc., to avoid catching fire.
- DO NOT operate the robot in the room where there are open fireplaces, lit candles or fragile objects on the floor or where there are candles on candlesticks, tables, etc., which may accidentally hit or bump into, thus leading to fire or causing damage to the appliance.
- DO NOT place anything on the robot or hit against the robot.
- NEVER use the power cable or plug that partly damaged.
- DO NOT operate this robot in areas where exist exposed electrical outlets on the floor.
- DO NOT operate the robot on waxed floor, which may result in the damage to the robot or the floor. It's recommended to use the robot on any hard or carpeted floors.
- This robot is designed to be used on floors without scratching them. Before cleaning your whole house, it's advised to perform a pre-test on your floor to ensure that no scratches are made.
- Ensure that everyone in the room is aware of the robot when cleaning to avoid stepping on it or the tripping hazard.
- Make sure the Dust Bin or the Filter are in place before using this robot.
- Remove all power cords and other items that could get tangled in the robot from the area to be cleaned before use.
- Before cleaning, please pick up some objects like loose clothing or paper due to the limited size of the openings. Otherwise, the openings may be blocked.
- Keep the robot free of line, hair, and anything that may reduce airflow.
- Clean the robot with a dry or damp cloth.
- The Power Adapter of Charging Station must be removed from the socket before cleaning robot or maintaining robot.
- Cleaning and maintenance shall not be done by the children without any adult supervision.
- Unplug the Charging Station when not in use for extended periods.
- DO NOT use the accessories or replacement parts from unauthorized channels. Only use the ORIGINAL parts provided by Tikom. Please directly contact us whenever they are needed.
- We assume no liability or responsibility for any fire, explosion or electrical shock caused by improper operation.

BATTERY

- A rechargeable Li-ion battery is installed in the robot.
- DO NOT attempt to disassemble or replace the battery in the robot by yourself as the incorrect operation might cause overheating, fire or injury.
- DO NOT expose the battery pack inside of the robot to any fire, heat source, direct sunlight or high temperature, which may result in the risk of explosion.
- DO NOT dispose of this robot or the battery pack in fire, any water or other liquids to avoid the risk of explosion.
- The Li-ion battery in the robot should be serviced or recycled by an authorized service provider, and must be recycled or disposed of separately from household waste. Dispose of the battery according to your local environmental laws and regulations.

FCC Caution

Any Changes or modifications not expressly approved by the party responsible for compliance could void the user's authority to operate the equipment.

This device complies with part 15 of the FCC Rules. Operation is subject to the following two conditions:

- This device may not cause harmful interference.
- this device must accept any interference received, including interference that may cause undesired operation.

Note:

This equipment has been tested and found to comply with the limits for a Class B digital device, pursuant to part 15 of the FCC Rules. These limits are designed to provide reasonable protection against harmful interference in a residential installation. This equipment generates, uses and can radiate radio frequency energy and, if not installed and used in accordance with the instructions, may cause harmful interference to radio communications. However, there is no guarantee that interference will not occur in a particular installation. If this equipment does cause harmful interference to radio or television reception, which can be determined by turning the equipment off and on, the user is encouraged to try to correct the interference by one or more of the following measures:

—Reorient or relocate the receiving antenna.

—Increase the separation between the equipment and receiver.

—Connect the equipment into an outlet on a circuit different from that to which the receiver is connected.

—Consult the dealer or an experienced radio/TV technician for help.

This equipment complies with FCC radiation exposure limits set forth for an uncontrolled environment. This equipment should be installed and operated with minimum distance 20cm between the radiator & your body.

This transmitter must not be co-located or operating in conjunction with any other antenna or transmitter.

ISED Warning

This device complies with Industry Canada licence-exempt RSS standard(s). Operation is subject to the following two conditions:

- this device may not cause interference, and
- this device must accept any interference, including interference that may cause undesired operation of the device.

Le present appareil est conforme aux CNRd'Industrie Canada applicables aux appareils radio exempts de licence. Sexploitation est autorisee aux deux conditions suivantes:

- l'appareil ne doit pas produire de brouillage, et
- l'utilisateur de l'appareil doit accepter tout brouillage radioelectrique subi, meme si le brouillage est susceptible d'en compromettre le fonctionnement.

The device is compliance with RF exposure guidelines, users can obtain Canadian information on RF exposure and compliance. The minimum distance from body to use the device is 20cm.

Le present appareil est conforme Apres examen de ce materiel aux conformite ou aux limites d'intensite de champ RF, les utilisateurs peuvent sur T exposition aux radiofrequences et la conformite and compliance d'acquerir les informations correspondantes.

La distance minimale du corps a utiliser le dispositif est de 20cm.

2.About Robot

2.1 What's in the Box

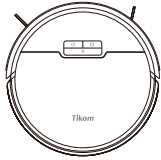

Robotic Vacuum Cleaner
(Dust Bin Included)

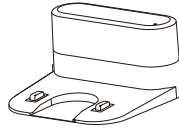

Charging Station



Remote Controller
with Battery

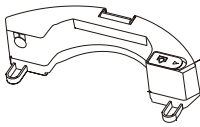

Electric Control Water Tank

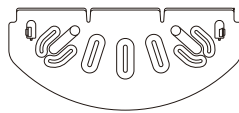

Mopping Cloth Holder

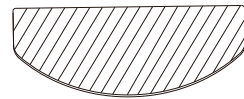

Spare Mopping Cloth

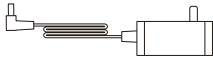

Power Adapter
(for Charging Station)

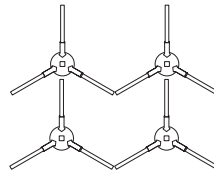

Side Brushes x4



Cleaning Brush

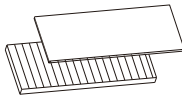

Spare HEPA Filter and Sponge



Boundary Strip(6.6ft/2m)

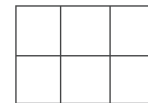

Adhesive Tapes x2



Cable Ties x 5



User Manual



Quick Start Guide

Note:

Figures and illustrations are for reference only and may differ from actual product appearance. Product design and specifications are subject to changes without notice.

2.2 Robot Anatomy

2.2.1 Top View

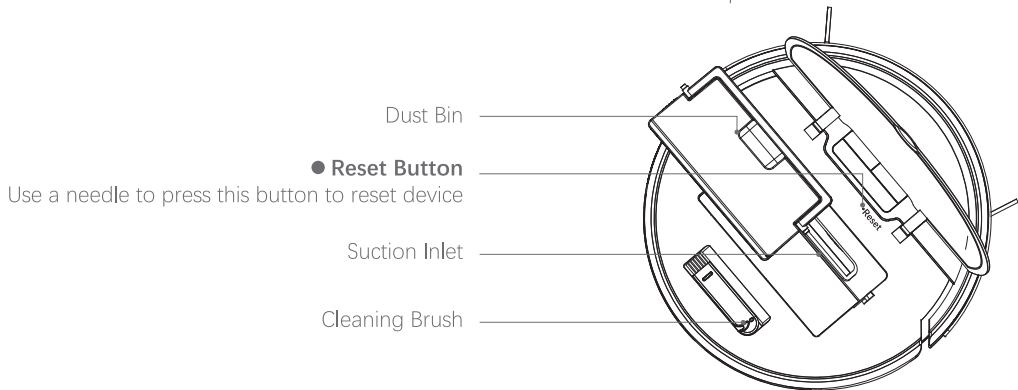
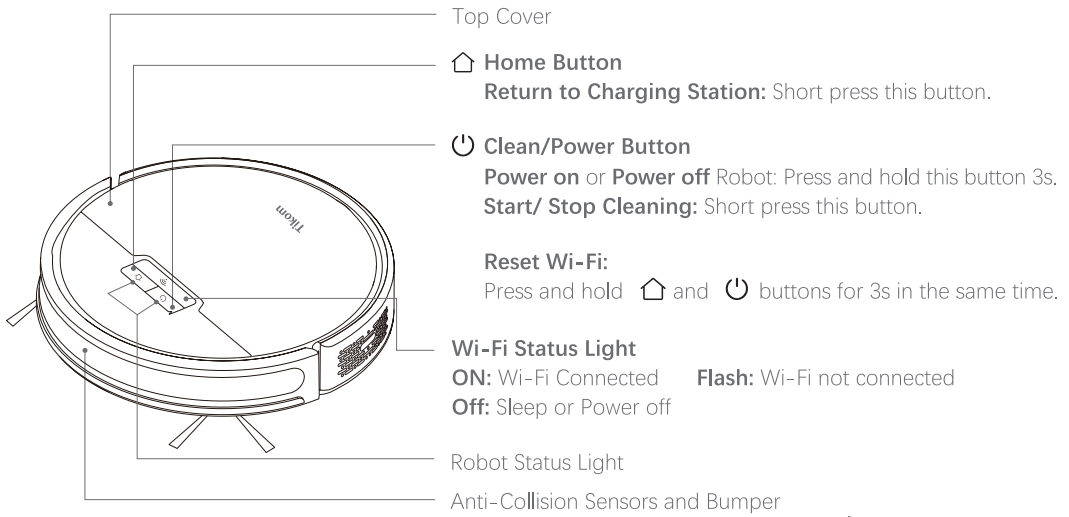

2.2.2 Bottom View

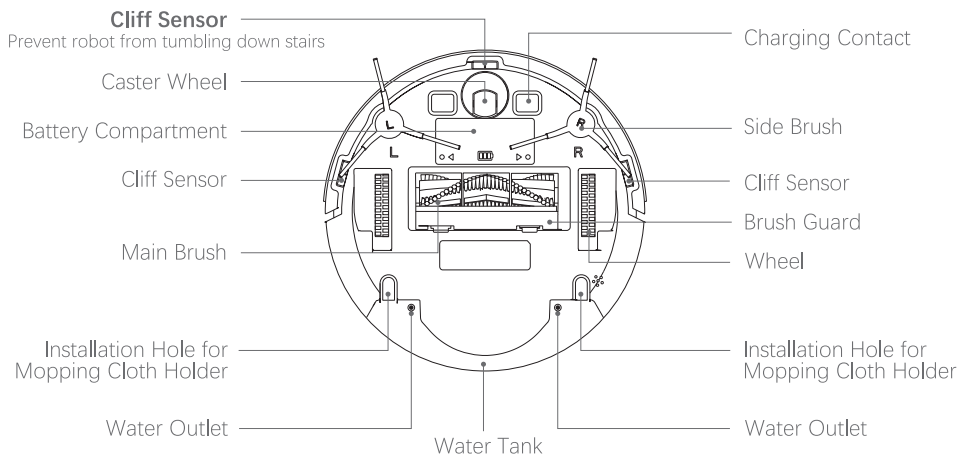

2.2.3 Dust Bin

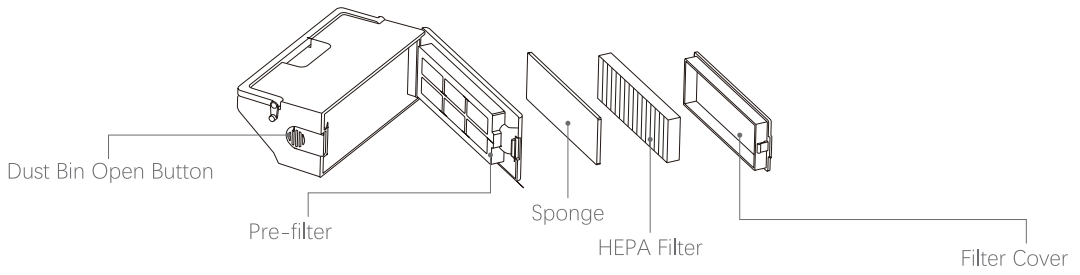

2.2.4 Charging Station

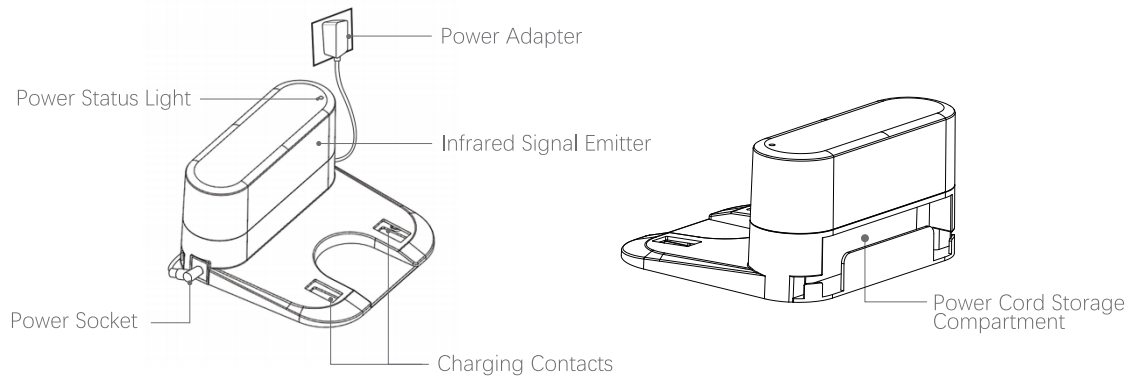

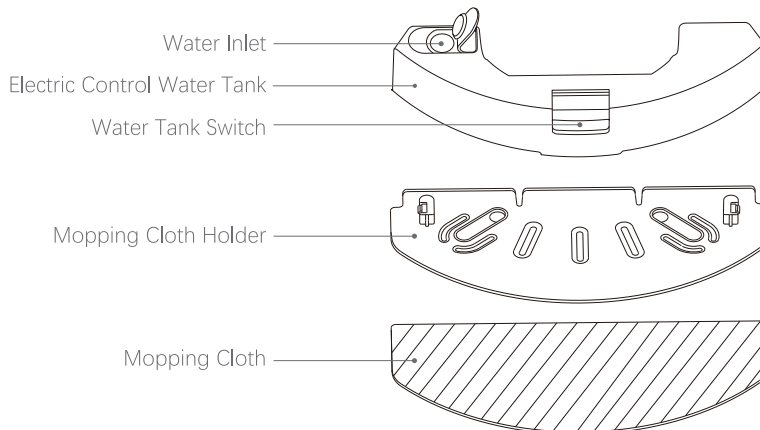

2.2.5 Mopping Module



2.3 LED Indication

Robot Status Light	Robot Condition	Status
Off	Not on Charging Station	In Sleep Mode: When robot stop cleaning or have errors, will enter Standby Mode; In Standby Mode for 10mins, will enter Sleep Mode. Short press power button or use TuyaSmart app could awake robot.
Solid Blue	On Charging Station	Full Charged
	Cleaning	Cleaning Mode
	Back to Charging Station	Back to Charging Station to recharge.
Flash Blue	On Charging Station	Charging
Solid Red	Back to Charging Station	Low Battery and Back to Charging Station to recharge.
Flash Red	Stop	Robot has error, Robot will have voice prompt to alarm which error , or could use TuyaSmart App to check exact error, For error troubleshooting details, please check "5.1.Error & Voice Alarm",on Page 30 in this manual.

Wi-Fi Status Light	Robot Condition	Status
Flash Blue	at Wi-Fi Setup	After press and hold  and  buttons at the same time for 3 seconds, Robot will have "Wi-Fi reset, ready for EZ mode connection"Voice, then follow TuyaSmart app instruction for Wi-Fi Connection. For Wi-Fi connection details, please check "3.4 Connect Robot with Wi-Fi",on Page 11 in this manual.
	Robot Power on	1.Wi-Fi is not connected successfully, please reset Wi-Fi or restart robot. 2.If Robot have "Wi-Fi connected"voice, then means Robot has connected your home router successful, but didn't connect TuyaSmart app server successfully. Wait several hours to recheck again.
Solid Blue	Robot Power On	Wi-Fi and app server connected Successfully.
Off	/	Robot is at Sleep Mode or Power Off .

3.Using Robot

3.1 Getting Started

1.Remove the protection material from both sides of the robot.

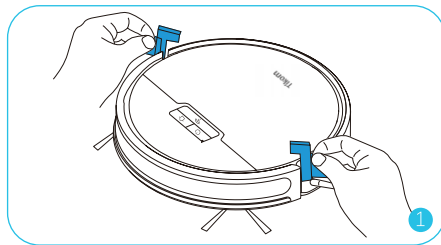

2.Install the side brushes before use.

Put the left brush (L) and right brush (R) against the letters L and R on the bottom respectively. Press side brushes until have "click" sound, then means side brush install well.

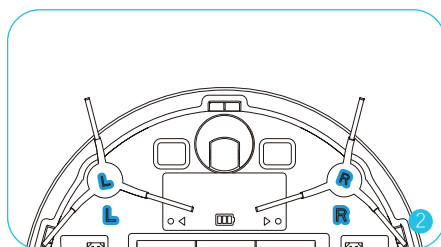

3.Place the Charging Station on a level surface and against a wall.

It is recommended to place the Charging Station against a wall, and on a hard-level surface rather than on rugs or carpets.

Recommend to use provided adhesive tapes to fix charging station on the ground.

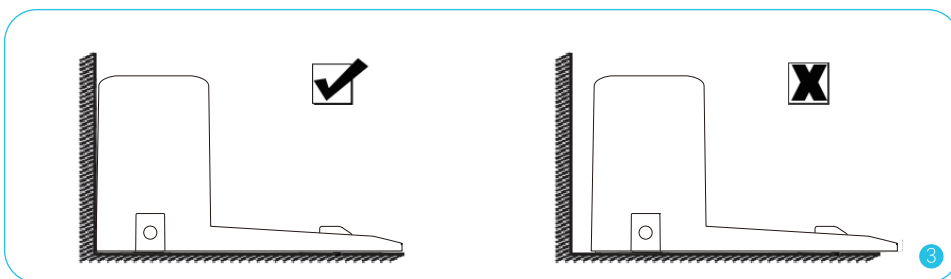

4.Remove objects within 3 ft/1 m of the left and right side and within 6 ft/2 m of the front of the Charging Station.

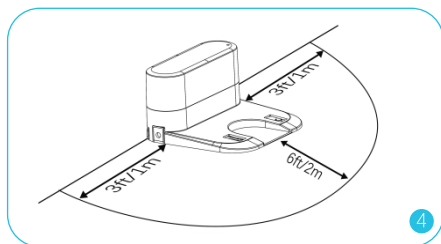

5. Connect the round connector of the adapter into the power socket on the Charging Station and the other end into a wall outlet.

When the Charging Station connects to AC power, the Power Status Light on the Charging Station is SOLID WHITE.

Always keep the Charging Station plugged in, otherwise Robot could not automatically return to it when Robot battery gets low.

Please put spare cable into storage compartment to avoid spare cable be exposed on the ground to entangle robot.

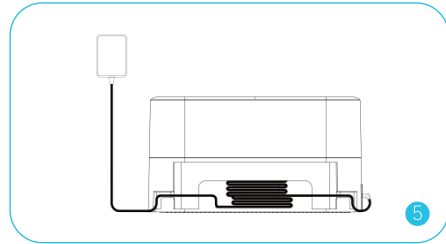
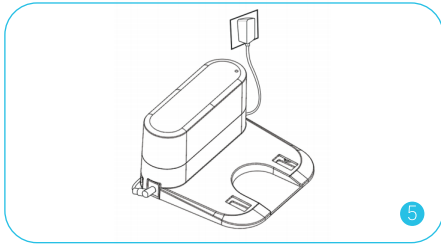

6. Please fully charge your robot before your first use. Manually align the Charging Contacts on the bottom of the robot with those on the Charging Station.

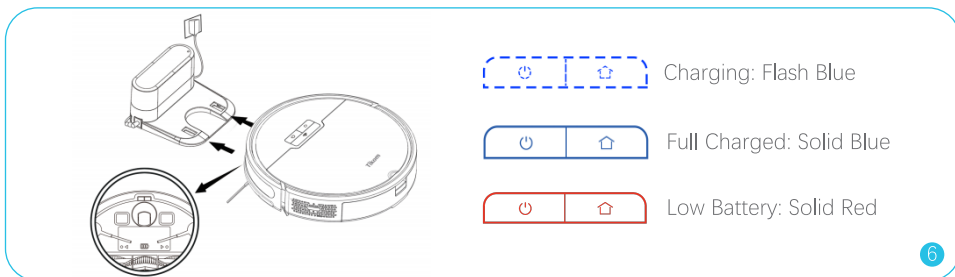

Notes:

- 1 It takes 6-6.5 hours to reach a full charge, which could last to clean for around 120 minutes with Auto Mode and the minimum suction power.
- 2 The robot will find and return to the Charging Station when the battery gets low; while it will not move when the battery gets critical low, please manually get it to charge.
- 3 To extend the battery's lifespan, please recharge the robot at least once every 3 months if not using for longtime.
- 4 Do not open the battery compartment and replace the battery by yourself. If the robot won't charge, please contact support.us@tikom.cc for further assistance.

3.2 Important Tips Before Usage



1. Please remove any objects from floor that may entangle robot vacuum, such as pet poop, socks, cloths, tissue, toys, slippery and power cords. You can use supplied Cable Ties to organize your wires and power cords.

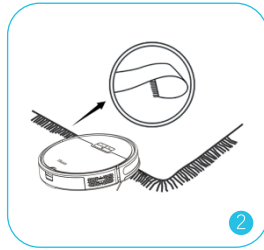

2. Before using the robot on a rug with tasseled edges, please fold the rug edges under.



3. Keep robot away from wet areas, such as kitchen or bathing room.

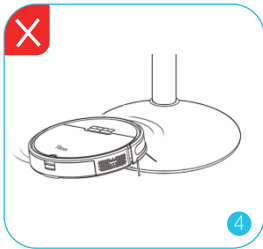

4. The round base of some Bar Chairs, Pedestal Tables, Pedestal Fans and Floor Lamps which robot could climb onto will affect robot mapping & navigation. So when robot cleaning, please remove these Bar Chairs, Pedestal Tables, Pedestal Fans and Floor Lamps with round base, or use supplied Boundary strip to block off problem areas.



5. Keep robot away from spaces between 2.56in/65mm--3.54in/90mm (Robot thickness is 3in/76 mm) to prevent robot from getting stuck, like sofa, cabinet or other furniture. If necessary, you could use supplied Boundary Strip to block off the problem areas.

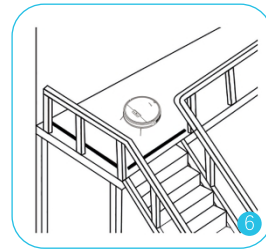

6. Cliff sensors will prevent robot from tumbling down stairs and steep drops in most cases. Cliff sensors are less effective if dirty or used on carpeted / reflective / very dark-colored floors. It's recommended to apply the provided Boundary Strip to block off areas where cliff sensors are less effective as described above.

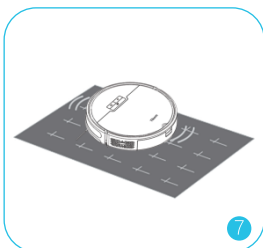

7. The Robot may not run on certain darker black colored surfaces since the Cliff Sensors that recognize an edge or a stair may regard black color as an edge, then the robot will not clean over it.

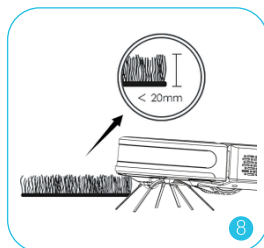

8. Avoid cleaning high-pile rugs thicker than 0.78 in/20 mm, as they may cause Robot to malfunction.

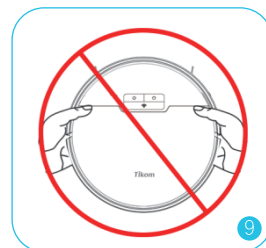

9. While your robot is cleaning, do not pick it up and move it, or move the charging station—this could impact the robot's ability to map your home or back to charging station.

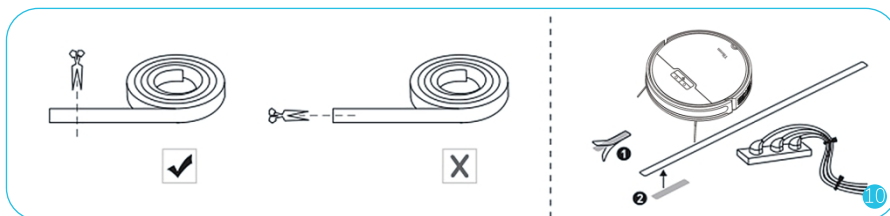

10. To keep Robot away from any area or item you do not want Robot to clean, apply the supplied Boundary Strip on the floor with the supplied adhesive tape to create a virtual barrier. Make sure the strips are placed FLAT on the floor.

3.3 Power On/Off Robot

Power On Robot: Press and hold the  button for 3 seconds.

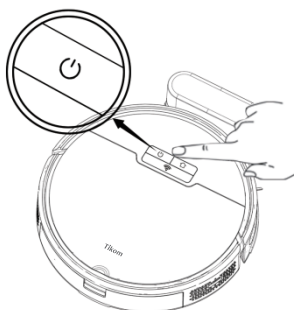

3.4 Connect Robot with Wi-Fi

To enjoy all available features, it is recommended to control your Robot via the TuyaSmart app thru 2.4GHz Wi-Fi.

3.4.1 app Downloading and Installation

3.4.1.1 app Downloading

Note: Please make sure your smart Phone or tablet is running iOS 10.0 (or above) or Android 4.4 (or above).

Option 1:

Search for TuyaSmart from App Store/Google Play, then download and install it onto your mobile device.

Option 2:

Scan the QR codes on robot or below to download and install onto your mobile device.

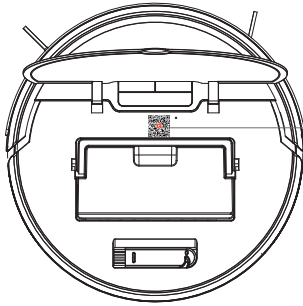

3.4.1.2 app Registration and Login

Launch TuyaSmart app, register an account with your mobile phone number or a valid email address at your first use, then login.

Note: For a successful connection, please allow TuyaSmart app to use your WLAN & Cellular Data when running it.

3.4.2 Wi-Fi Connection Requirement

3.4.2.1 Mobile Device Requirement

Make sure your Smartphone or tablet is connected to a 2.4GHz Wi-Fi.

Make sure Bluetooth  on your smartphone or tablet is ON.

3.4.2.2 Robot Requirement

- 1.The Wi-Fi Status Light on Robot is flashing blue.
- 2.Robot is attached to the Charging Station to ensure it has enough power during setup.

3.4.2.3 Wi-Fi Requirement



- 1.Make sure the robot and your mobile device are close to the router when connection.
- 2.Make sure you've entered the correct Wi-Fi name and password when connecting.
- 3.Avoid using an emoji or special characters or symbols in your Wi-Fi name and password.
- 4.It's not recommended to use a VPN (Virtual Private Network) or Proxy Server.
- 5.If your router is a 2.4GHz / 5GHz dual-band router, please select the 2.4GHz network, robot only support 2.4GHz network.
If 2.4GHz and 5GHz Wi-Fi use same Wi-Fi name in router, please enter router control page to rename 2.4GHz and 5GHz Wi-Fi. Then make mobile phone to connect with new 2.4GHz Wi-Fi.
- 6.When connecting to a hidden network, make sure you enter the correct network name, SSID (case sensitive), and connecting to a 2.4GHz wireless network.
- 7.When using a network extender/repeater, make sure the network name (SSID) and password are the same as your primary network.
- 8.Your Wi-Fi router supports 802.11b/g/n and IPv4 protocol.

9.WPA and WPA2 using TKIP, PSK, AES/CCMP encryption.

10.WEP EAP (Enterprise Authentication Protocol) is not supported.



11.Use Wi-Fi channels 1-11 in North America and channels 1-13 outside North America (refer to local regulatory agency).

3.4.3 Wi-Fi Status Light

Wi-Fi Status Light	Robot condition	Meaning
Flash Blue	At Wi-Fi Setup	After press and hold  and  buttons at the same time for 3 seconds, Robot will say "Wi-Fi reset, ready for EZ mode connection", then follow TuyaSmart app instruction for Wi-Fi Connection.
	Robot Power on	1.Wi-Fi is not connected successfully, could reset Wi-Fi or restart Robot. 2.If Robot have "Wi-Fi connected" voice, means app server have problem, Robot couldn't connect TuyaSmart app server successfully. Wait several hours to recheck again.
Solid Blue	Robot Power	Wi-Fi and TuyaSmart app server connected Successfully.
Off	/	Robot is at Sleep Mode or Power Off Mode.

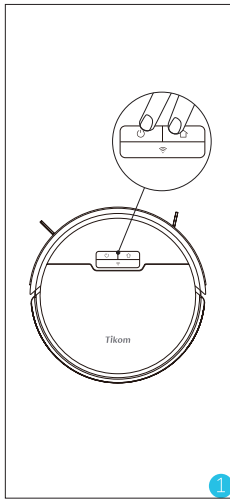
3.4.4 Connect with TuyaSmart app



1. Press and hold  and  buttons on the robot at the same time for 3 seconds, Robot will say "Wi-Fi reset, ready for EZ mode connection", and Wi-Fi Status Light will Fast Flash.

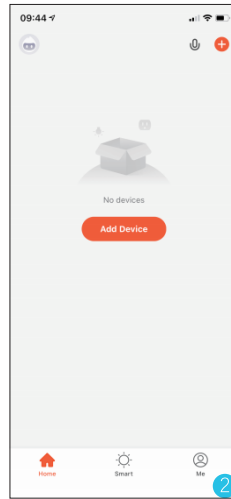

2. Open TuyaSmart app, Tap "Add Device" or "+" at the upper right corner.

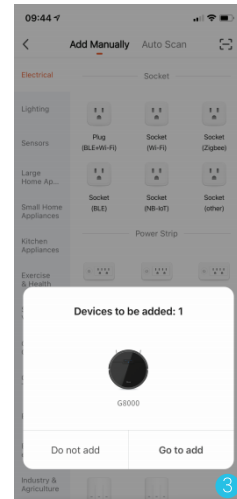

3. Will appear this page, select "Go to add".

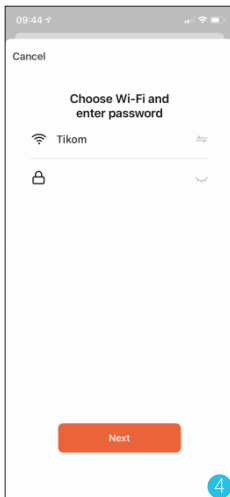

4. Select the same router's 2.4GHz Wi-Fi as mobile phone and enter the correct password. Tap "Next"

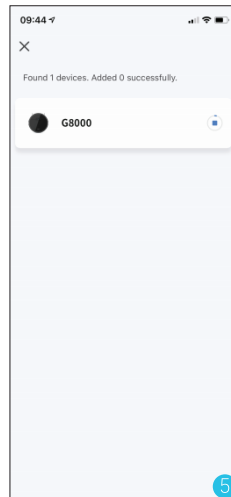

5. Connecting.

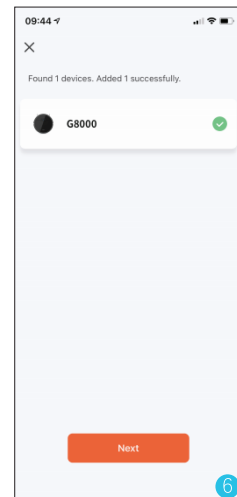

6. Connection successful, and Robot will say "Wi-Fi Connection Successful", and Wi-Fi Status light will be solid.

Note:

After finish setting robot vacuum Wi-Fi, Mobile Phone could use anyway to control robot vacuum thru app as you want, not only 2.4GHz Wi-Fi which is used to set robot vacuum Wi-Fi. In other words, after finish setting robot vacuum Wi-Fi, Mobile Phone could use 2.4GHz/5GHz Wi-Fi or 3G/4G/5G Cellular Data to control robot vacuum thru TuyaSmart app in anywhere and anytime.

3.4.5 TuyaSmart app introduction

Open TuyaSmart app and enter robot control page as blow:

1.Go to Robot Non-functional Setting Page

2.Real Time Cleaning Map display

3.Start/Pause

4.Go back to Charging Station

5.Smart Cleaning

6.Edge Cleaning

7.Spot Cleaning

8.Random Cleaning

9.Setting Schedule Cleaning time

10.Go to Functional setting Page

11.Manual Cleaning



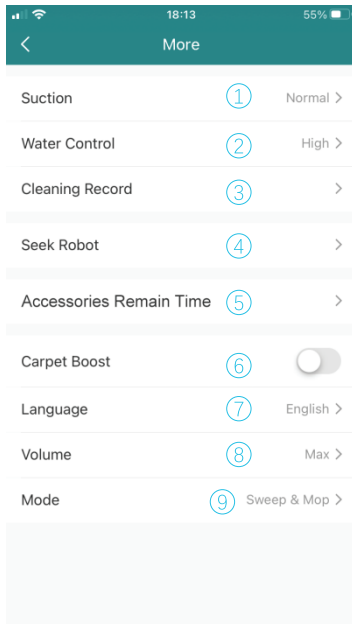

Functional Setting Page Introduction as below:

- 1.Suction Power setting
- 2.Mop Water Control
- 3.Cleaning Record
- 4.Find Robot
- 5.Accessories Remain Time
- 6.Carpet Boost Switch
- 7.Robot Speak Language setting
- 8.Robot Speaker Volume
- 9.Working Mode Choice

3.4.6 Work with Amazon Alexa or Google Assistant

Amazon Alexa or Google Assistant is a smart voice control device that enables you to control Robot with your voice.

Before you start, make sure that:

- 1.Robot is attached to the Charging Station to ensure Robot has enough power.
- 2.Robot is connected with the TuyaSmart app successfully.
- 3.You have an Amazon Alexa-enabled device (i.e. Amazon Echo, Echo Dot and Amazon Tap, Echo Show, Echo Spot) or a device enabled with the Google Assistant (i.e. Google Home, Google Home Mini). These devices are sold separately.
- 4.The Amazon Alexa app or Google Home app is already installed on your smart device, and you have created an account.
- 5.You have registered your Amazon Alexa-enabled device onto Amazon Alexa app or your Google Assistant-enable device onto Google Home app.

To control Robot with Amazon Alexa or the Google Assistant

Step 1: Open TuyaSmart app and enter robot page, and tap top-right Pen icon;

Step 2: Tap Amazon Alexa icon or Google Home icon to link with Alexa or Google Home.

Just follow app instruction, then could add your robot into Amazon Alexa app or Google Home app.

The image shows two screenshots from the TuyaSmart app. The top screenshot shows the robot's status page, which is currently in 'Charging' mode. It displays a cleaning area of 6.5 m², a cleaning time of 4 minutes, and 98% residual electricity. Below this are controls for 'Map' and 'Charge', and a 'Mode' section with options for 'Smart', 'Edge Cleaning', 'Spot cleaning', and 'Random'. The bottom screenshot shows the 'Robot' settings page, with a focus on the 'Third-party Control' section. This section includes icons for 'Alexa', 'Google Assistant', and 'XIAODU'. A callout box labeled '1' points to the pen icon in the top right of the first screenshot. Another callout box labeled '2' points to the 'Alexa' and 'Google Assistant' icons in the 'Third-party Control' section.

You could talk below voice instruction to Amazon Alexa-enabled device or Google Assistant-enabled device to control your robot.

Voice instruction of Amazon Alexa or Google Home device

Device	Voice Instruction	Meaning
Amazon Alexa	"Alexa, turn on robot (or your robot's name if you changed the robot name)."	Auto Cleaning
	"Alexa, turn off robot."	Stop Cleaning
Google home	"OK Google, turn on robot(or your robot's name if you changed the robot name)."	Auto Cleaning
	"OK Google, turn off robot."	Stop Cleaning

3.5 Cleaning Mode

3.5.1 Smart Cleaning

Press  on Robot or press Smart button on app to start Smart Cleaning mode. Robot will clean all accessible space in zigzag route until the battery gets low.

There is 3 level suction power setting in APP (Gentle, Normal & Strong). Cleaning time, cleaning ability and noise is different for different suction power.

Gentle: about 120mins ;Normal: about 90mins; Strong: about 60mins.
Above working time is just for reference, will decrease after long time usage.

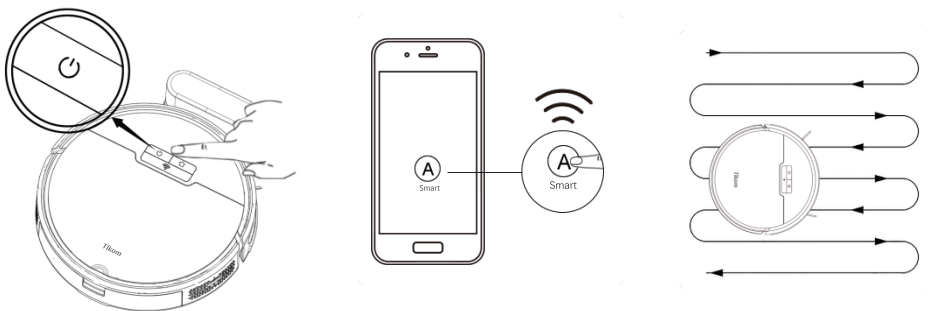

Note:

- 1 Robot will return to the Charging Station automatically to make a self-charging, when the battery level becomes low or when Robot finishes cleaning.
- 2 We recommend to fully charge the robot, then operate it as needed. If no cleaning plans, please let the robot always connect with the Charging Station.
- 3 If the robot is not managed to find the Charging Station due to obstacles or getting stuck, please manually get it to contact with the Charging Station.

3.5.2 Manual Cleaning

You can direct Robot to clean a particular area by using the directional buttons on app after choosing Manual.

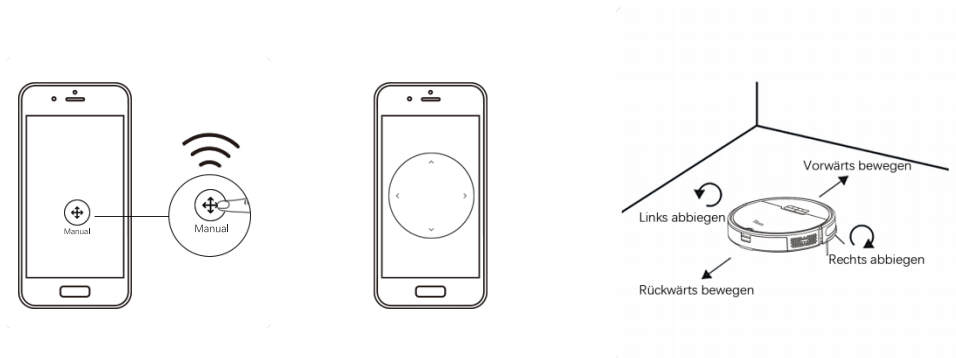

3.5.3 Spot Cleaning

This cleaning mode aims to intensively clean a specific area with 3.9ft./1.2m diameter.

Step 1:

Locate any area where needs to be cleaned intensively, namely there exist much debris or dust, then move the robot to the center of the area by manual thru app ,which indicated in 3.5.2 "Manual Cleaning" on this Page.

Step 2:

Press Spot cleaning button on app to initiate the spot cleaning process in a spiral pattern. The maximum diameter of the spiral circle is around 1.2 meter (3.9ft). The process will last around 2 minutes, then the robot will go back to start point and enter standby mode if no any operation is resumed.

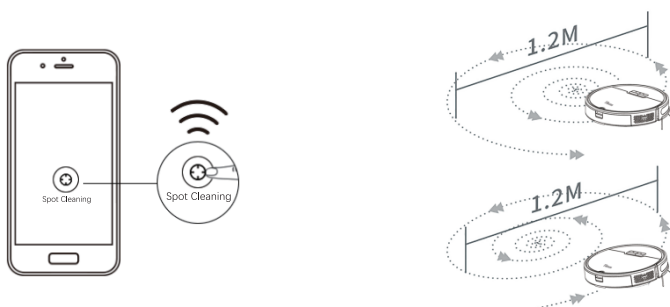

3.5.4 Edge Cleaning

This mode is to thoroughly clean the edges along the wall or any furniture. Press Edge cleaning button on app to initiate the Edge cleaning process.

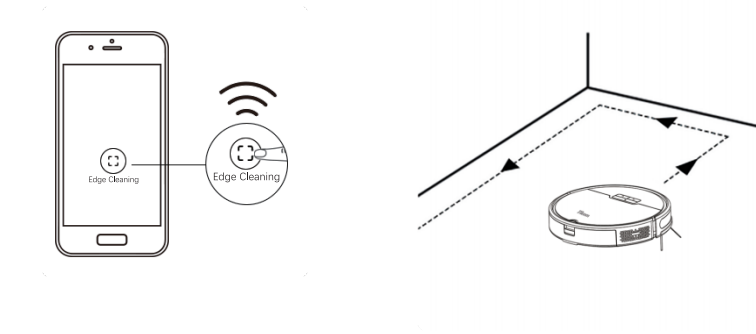

3.5.5 Random Cleaning

This mode is to clean in random routine.

This mode could be used for special carpet environment which robot couldn't clean in zigzag routine.

Press Random cleaning button on app to initiate the random cleaning process.

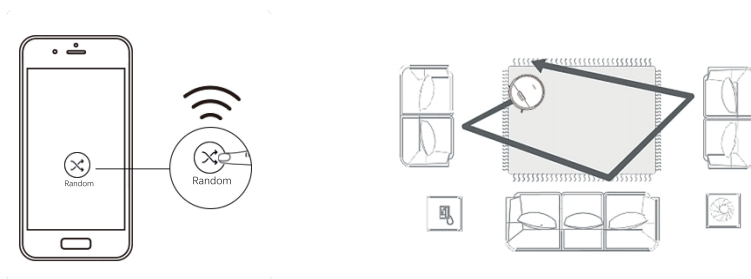

3.5.6 Carpet Boost

This function is set in app.

When enable this function in app, the robot automatically increases the suction power to Max on carpet to provide a deeper clean for carpet.

When on a hard surface, the robot will return to the setting suction power to provide just the right amount of power to save power.

This function will reduce the total cleaning time, and increase the noise level. If clean time is less or noise, you can disable this function in app.

3.6 Schedule Cleaning Setup

This function is set in app.

Thru app,you can schedule Robot to start cleaning at a particular time.

You can set the time and customize the cleaning schedules from Sunday to Saturday.

3.7 Sleep Mode

To reduce battery consumption, the robot will go into the Sleep Mode when it is in Standby Mode for 10 minutes;

Press  on the robot or any clean button on app to wake robot up.

Robot will be in Standby Mode in below condition:

- 1.Stop cleaning thru  button or app.
- 2.Robot has error and stop cleaning.

3.8 Error

If an error occurs, the Robot Status Light will be flash red and a voice prompt will sound. Refer to "5.1 Error & Voice Alarm" on page 30 for troubleshooting.

The robot will automatically enter Sleep Mode after 10 minutes of inactivity in an error state.



Note:

Once error is fixed and robot start cleaning again, cleaning map in app will be re-draw as new, wouldn't draw on last cleaning map, Because fixing robot error would change robot place and direction, if draw on last cleaning map, will disorder cleaning map.

3.9 Charging

Auto Charging

- 1.When the battery gets low or cleaning finish, the robot will return automatically to the Charging Station to make a self-charging.
- 2.We recommend to fully charge the robot, then operate it as needed. If no cleaning plans, please let the robot always connect with the Charging Station.
- 3.If you set a schedule for Auto Mode, the robot will respond to the schedule even in low-battery status, but can't perform the cleaning due to the low battery.
- 4.If the robot is not managed to find the Charging Station due to obstacles or getting stuck, please manually get it to contact with the Charging Station.

Manual Charging: In Standby Mode, press the  button on robot or press  on app to start recharging.

3.10 Boundary Strip Usage

Boundary strip aims to set blocked-off areas, Robot will recognize the Boundary Strip and will not cross strip into the blocked-off areas.

Blocked-Off areas is listed as below:

- A. Some furniture spaces between 2.5in/65mm--3.5in/90mm (Robot thickness is 3in/76 mm) to prevent robot from getting stuck, like sofa or cabinet.
- B. Some place don't want robot to clean, like pet food bowls, kids toy, kitchen or bathing room.

Once identify Blocked-Off areas, please do as blow:

1. Identify the area or item you do not want Robot to get close to.
2. If necessary, use scissors to cut the Boundary Strip to a shorter length. Be sure to correctly measure the length before cutting.

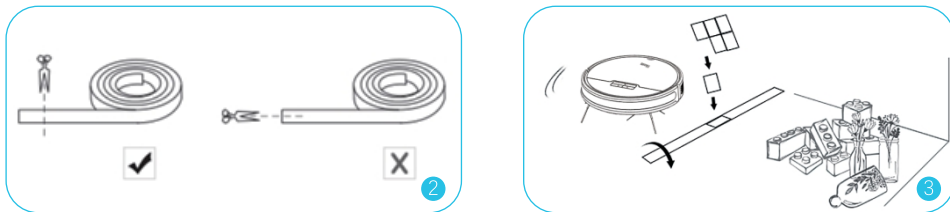

3. Used supplied adhesive tape to paste the Boundary Strip flat on the floor, make sure the strip is placed FLAT on the floor or under an rug area.

Notes:

- ① If the Boundary Strip is rolled up, remove and then re-apply on the floor with adhesive tape. Otherwise the Boundary Strip may not work well.
- ② Make sure the strip is affixed on the same surface level as the robot.
- ③ Be careful not to damage the floor when using adhesive tape.
- ④ When use for carpets, could put Boundary Strip under Carpets.
- ⑤ Keep the Boundary Strip away from objects that emit excessive heat.

3.11 Mopping the floor

1. Take out Water Tank

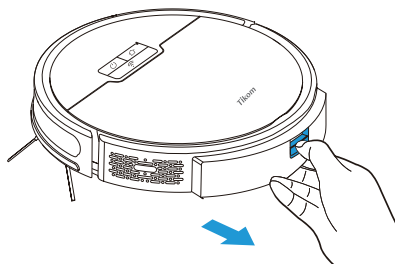

Note:

- ① Do not spray and immerse the water tank.
- ② Floor cleaners or disinfectants may damage the water tank, Don't add them into water tank.

2. Open the water tank cover, fill water and reseal it carefully.

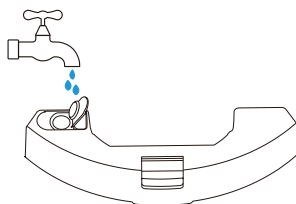

3. Install Mopping cloth: Attach Mopping cloth onto Mopping cloth holder.

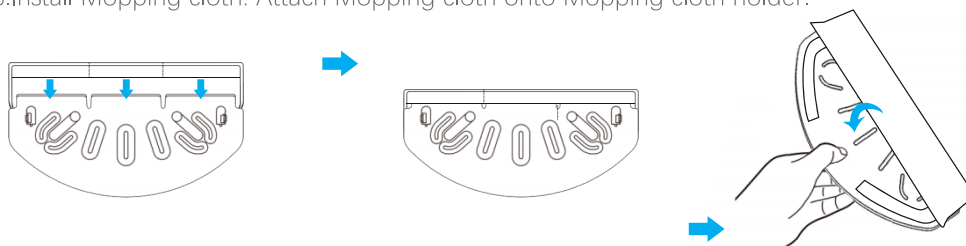

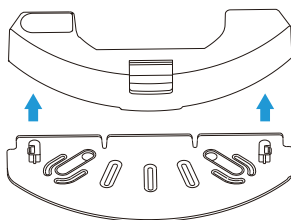

Note: It is suggested to clean the mopping cloth before using, to guarantee the cleaning result.

4. Install Mopping cloth holder onto water tank

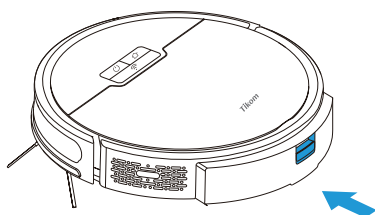

5. Install water tank back to robot.



6. Tap the  button on the Robot or press "Smart " button on app to enable the mopping mode. Then there is voice prompt "Start Mopping".

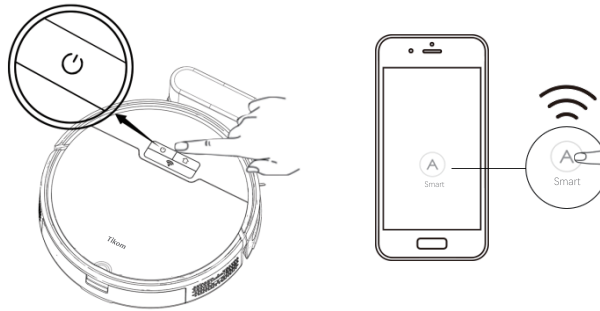

There is 3 level mopping control, High/Middle/Low.

If water tank is full, High level mopping time is about 60mins, Middle is about 80mins, Low is about 110mins.

Note:

- ① For safety purposes, remove mopping module (water tank and mopping cloth holder) in case of charging or out of operation.
- ② Do not use the mopping function on the carpet.
- ③ To achieve a better mopping result. Suggest cleaning floor before mopping.

3.12 Firmware Update

Update robot firmware thru Tuya Smart app as below picture.

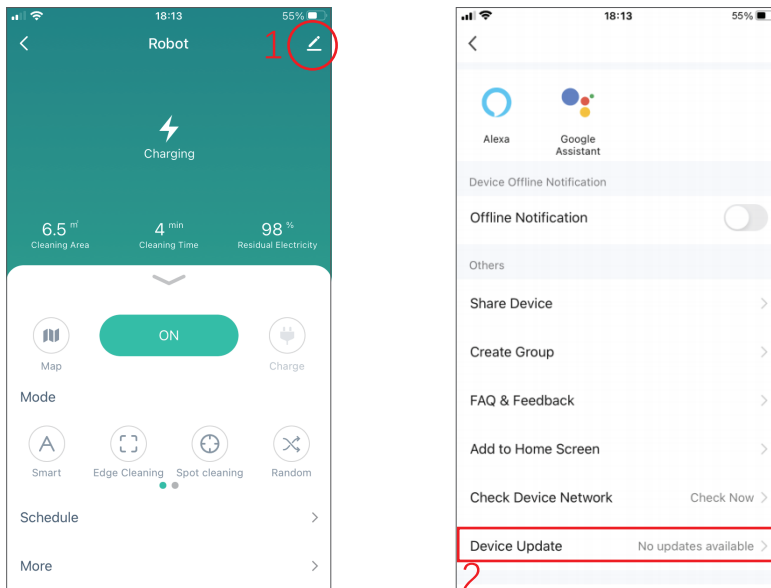

To upgrade the firmware, the power must be equal to or greater than 50%. It is recommended that you place the Robot on the charging station for upgrade.

4. Maintenance and Care

4.1 Cleaning and Replacement Frequency

To optimize the performance of your robot, we recommend to perform a regular maintenance and cleaning for some parts in the robot.

CLEANING AND REPLACEMENT FREQUENCY

Part	Cleaning Frequency	Replacement Frequency
Dust Bin	After each use	/
HEPA Filter	Once per week (Twice per week if you have pets)	1. Every 2 months. 2. On app, Filter life time is end. Replace filter meet above any condition.
Side Brush	Once per week	1. Every 3-6 months. 2. When it's visibly worn. 3. On app, Side Brush life time is end. Replace Side Brush meet above any condition.
Main Brush	Once per week	1. Every 6-12 months. 2. When it's visibly worn. 3. On app, Main Brush life time is end. Replace Main Brush meet above any condition.
Brush Guard	Once per month	/
Sensors	Once per month	/
Charging Contacts	Once per month	/
Caster Wheel	Once per month	/
Water Tank	After each use	/
Mopping Cloth	After each use	When it's visibly worn

Note:

- 1 Before performing cleaning and maintenance tasks on Robot, turn the robot OFF and unplug the Charging Station.
- 2 Tikom manufactures various replacement parts and fittings, Please contact Customer Service (support.us@tikom.cc) for more information on replacement parts.

4.2 Clean Dust Bin and Filter

1. Open the top cover of the robot, lift the handle of dust bin and take out dust bin.
2. Press the switch of dust bin to open it and pour out dust into trash bin.
3. Open Filter cover to take out HEPA Filter, Sponge and Filter Cover.
4. Tap the HEPA dust into trash bin. Sponge and filter cover could be washed by water, then dry them before usage.

Note: *Couldn't wash HEPA by water.*

5. Rinse Pre-Filter and dust bin with clean water without any detergent. Dry them before usage.
6. Re-install Sponge, HEPA and Filter Cover onto Pre-filter, then put back dust bin into robot.

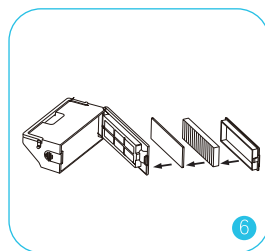
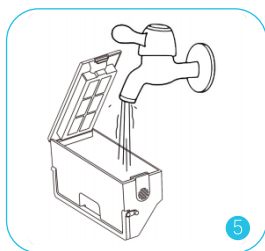
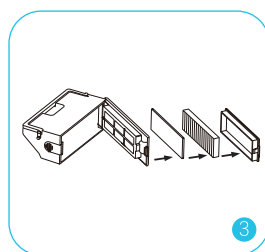
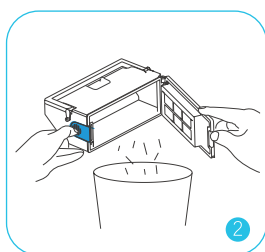
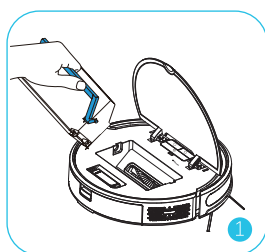

Note:

- 1 You can wash the dust bin, pre-filter, Filter sponge and Filter Cover with water. Be sure to air-dry them thoroughly before reassembling.
- 2 Do not wash the HEPA with water, as it may damage the HEPA and reduce the suction power.

4.3 Clean Main Brush

1. Press buckle on the brush guard to open it.
2. Take out main brush.
3. Open main brush cap on two sides of main brush, remove and clean hair or dirt on two side.
Re-install cap onto main brush.
4. Use the blade on the supplied Cleaning Brush to cut any hair or string that is wrapped on the main brush, and use brush to remove dirt on main brush.
5. Install Main Brush into robot, please attention the direction, inserting the fixed protruding end first, then clicking into place.
6. Press down to install the brush guard into place.

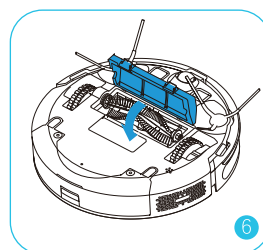
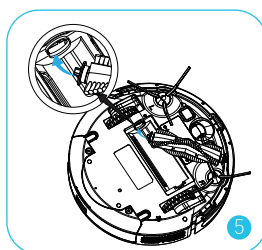
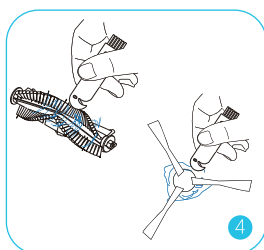
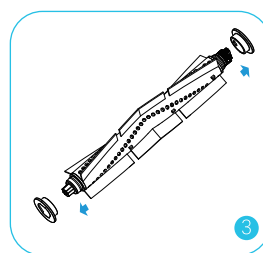
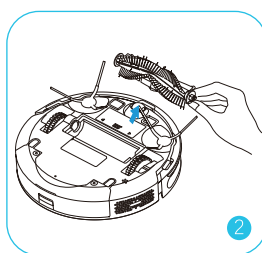
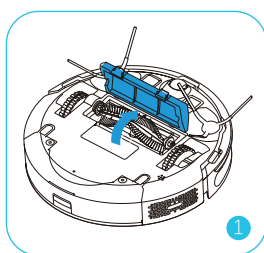

4.4 Clean Side Brush

- 1.Remove the side brushes.
- 2.Carefully unwind and pull off any hair or string that is wrapped between the robot and the side brushes.
- 3.Use a cloth dampened with warm water to remove dust from the brushes or to gently reshape them.
- 4.Reinstall side brush onto robot.

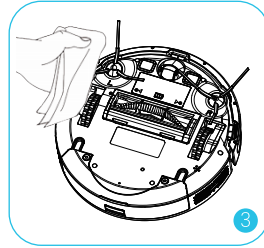
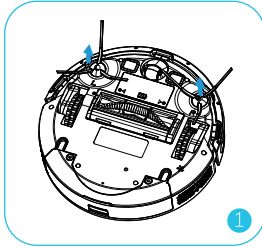

Note:

- 1 Only use the side brushes when they are completely dry.
- 2 To protect your wooden or carpeted floor, our side brushes are made of soft materials and may become curled after used for some time, but it will not affect the cleaning effect.

4.5 Clean Sensor and Charging Contacts

- 1.Use a damp cloth to clean all sensors on the robot and the Charging Station.
- 2.Use a dry cloth to clean the charging contacts on the robot and Charging Station.

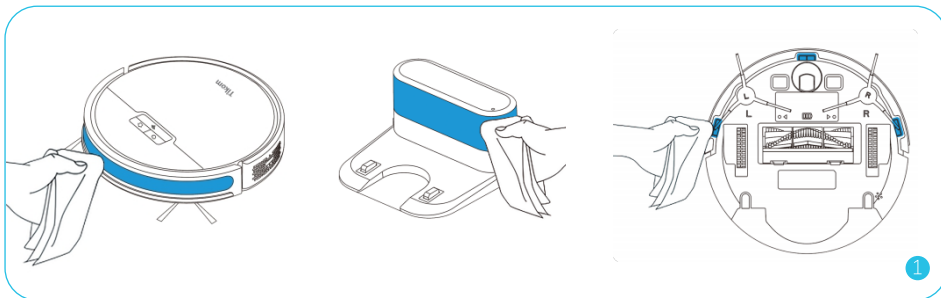

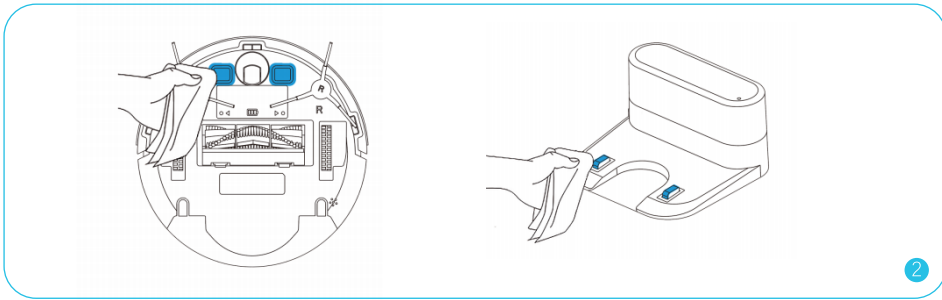

Note: Before Cleaning the charging contacts on the robot and Charging Station, turn the robot OFF and unplug the charging station.

4.6 Clean Caster Wheel

The Caster Wheel can't be pulled out, please remove any hair or debris that is wrapping the wheel or entangled inside the wheel cavity with the provided Cleaning Brush.

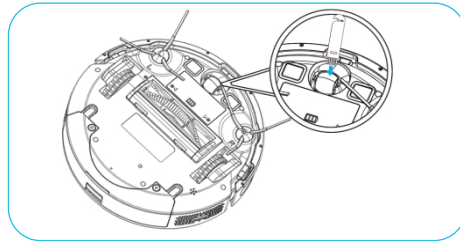

Note: Do not clean the Caster Wheel with water.

4.7 Water Tank and Mopping Cloth Maintenance

- 1.Remove the Mopping Cloth from the Mopping Cloth Holder and wash it.
- 2.Empty the remaining water and rinse the Water Tank to clean it.
- 3.Air-dry the water tank and mopping cloth.
- 4.Stick the Mopping Cloth and fix it to the Mopping Cloth Holder.

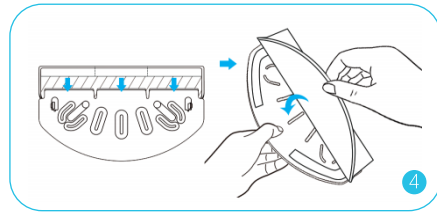
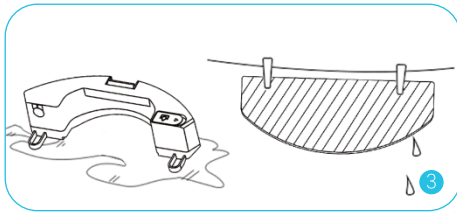
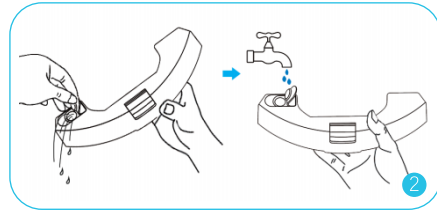
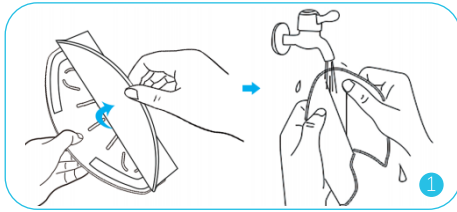

Note:

- ① Do not use hot water or any cleaning solution to clean the water tank, which will cause damage to it.
- ② Do not use hot water to clean the mopping cloth.

5.Troubleshooting

5.1 Error & Voice Alarm

When a runtime error occurs, the Robot Status Light flashes red and a voice prompt is given, also have error displayed on app.

Please use the table below to solve the problem.

Error Prompt	Cause	Solution
Error 1: Insert dust bin.	1.Dust bin doesn't install well. 2.Dust bin is taken out.	Reinstall dust bin.
Error 2: Put the vacuum on the floor before starting.	1.Robot is picked up or suspended in the air. 2.Cliff sensor is dirt.	1.Please move the robot to a flat surface and restart robot. 2.Clear cliff sensor by damp cloth.
Error 3: Move the vacuum to a safe area before starting.	1.Robot is blocked or placed in a high place. 2.Cliff sensor is dirt.	1.Please move the robot to a flat surface and restart robot. 2.Clear cliff sensor by damp cloth.
Error 4: Put the machine flat on the ground before starting.	1.Robot is tilted. 2.Cliff sensor is dirt.	1.Please move the robot to a flat surface and restart robot. 2.Clear cliff sensor by damp cloth.

Error 5: Front bumper is stuck.	Front bumper is stuck.	Please gently press the left, middle and right part of the bumper to check whether it can pop out. if still have error, please move robot to a new position and try again.
Error 6: Suction is not working well, please check.	The suction inlet of your robot is being blocked.	1.Power off the robot, then remove and empty the Dust Bin. 2.Make sure there is no hair or debris blocking the suction inlet.
Error 7: The vacuum is stuck.	Robot is stuck or trapped.	Clear any obstacles in the surrounding area or move robot to an open ground before starting.
Error 8: Wheels are Stuck.	Left or right wheels may be stuck or entangled with foreign objects.	Power off robot, then please check the wheels and remove the foreign objects.
Error 9: Main Brush is Stuck.	Main brush may be stuck or entangled with foreign objects.	Power off robot and take off brush guard, then please check the main brush and remove the foreign objects.
Error 10: Side brush is stuck.	Side brush may be stuck or entangled with foreign objects.	Power off robot, then please check the side brush and remove the foreign objects.
Error 11: Back to the beginning.	1.Robot can't find charging station. 2.Charging station isn't powered on.	1.To check if charging station is powered and power indication on charging station is on. 2.Put robot onto charging station.

If above solution don't work, please contact support.us@tikom.cc for help.

5.2 Frequently Asked Question

Problems	Solutions
Robot cannot be activated.	<ol style="list-style-type: none"> 1.Make Sure the battery is full charged, which in app robot battery electricity is shown 100%. 2.Turn Off the robot, wait for 5seconds and restart it. 3.The robot only could work well among the ambient temperature 0°C to 40°C, if beyond this temperature range, robot will work abnormal. 4.Please use a needle to press Reset button which is under top cover to reactivate robot. 5.If Still have problem, please contact support.us@tikom.cc for assistant.

<p>Robot stops working suddenly.</p>	<ol style="list-style-type: none"> 1. Check if robot is trapped or stuck on an obstacle. 2. Check if robot has error alarm (for details, please check 5.1 Error & Voice Alarm, on page 30). 3. Check if the battery level is too low. 4. If you still have trouble, turn off the robot, wait for 5 seconds and restart it.
<p>You cannot schedule cleanings.</p>	<ol style="list-style-type: none"> 1. Make sure the robot is turned on. 2. You can set the time of day and scheduled cleaning time via app. 3. Make sure the scheduled time has been set correctly. 4. Check if Robot power is too low to start cleaning, Scheduled cleaning will be started only when the remaining power is 20% or above. 5. Cleaning schedules are erased when Robot is powered off please reset schedule cleaning on app again. 6. Check if robot has error alarm (for details, please check 5.1 Error & Voice Alarm, on page 30), it can't start the scheduled cleaning.
<p>Poor cleaning ability or dust falling out.</p>	<ol style="list-style-type: none"> 1. Check if dust bin is full and needs emptying. 2. Check if Main Brush is stuck by some foreign objects. 3. Check if any obstructions are blocking the suction inlet. 4. Check if HEPA filter is blocked and needs cleaning. 5. Check if the HEPA filter is wet due to water or other liquid on the floor. Air-dry the filter completely before use.
<p>Robot produces loud or sharp noises.</p>	<ol style="list-style-type: none"> 1. It is a normal phenomenon that Robot produces certain sound during cleaning. Arrange your cleaning time properly to avoid being interrupted by the sound. 2. If a sharp noise is heard, check if the Main Brush, Side Brush or Wheel is intertwined by any foreign objects. Remove the foreign objects twisted around Main Brush, Side Brush or Wheel. 3. Check if the robot collected the objects that can make noise inside of the Dust Bin 4. If you still have trouble, contact support.us@tikom.cc for help.
<p>Robot cleaning time is too short</p>	<ol style="list-style-type: none"> 1. Please connect robot with app thru 2.4GHz Wi-Fi. 2. Full charged robot and check if robot battery electricity shown in app is 100%. 3. Change the suction power in app to "Gentle", and try cleaning. 4. In our lab test, Gentle suction could clean about 120mins, Normal suction is 90mins and Strong suction is 60mins. If after full charged and cleaning time is shorter than our lab test, please contact support.us@tikom.cc for assistant.

Robot cannot be charged.	<ol style="list-style-type: none"> 1. Check if the Power Status Light on the Charging station lights up. If not, contact support.us@tikom.cc to repair or replace the Charging station. 2. Clear the charging contact pins on charging station and robot with a dry cloth. 3. Check if you can hear a voice prompt " Start charging" , when robot is docked onto the Charging Station. 4. If not, please use a needle to press Reset button which is under top cover to reset robot, and try again above step 3 to check. 5. If Still have problem, please contact support.us@tikom.cc for assistant.
Slow charging speed.	<ol style="list-style-type: none"> 1. When used at high or low temperatures(>40°, <0°), the robot will automatically reduce the charging speed so as to extend battery life. 2. Clear the charging contact pins on charging station and robot with a dry cloth. 3. Check if used the right power adapter with charging station.
Robot cannot return to the Charging Station.	<ol style="list-style-type: none"> 1. Remove objects within 3 ft/1 m to the left and right side and within 6 ft/2m of the front of the Charging Station. 2. When Robot is in the vicinity of the Charging Station, it will return more quickly. However, if the Charging Station is located far away, Robot will need more time to return. Please be patient as it works its way back. 3. Clean the charging contact pins on charging station and robot with a dry cloth, and sensors on charging station and robot with damp cloth, details refer to "4.5.Clean Sensor and Charging Contacts" at page 28.
Unable to return to the charging station after spot cleaning or position change.	<p>The robot map will be disorder after spot cleaning or a significant position change. If the charging station is far away, the Robot may not be able to automatically return for recharge. Please put it onto the charging station manually.</p>
Main Brush does not rotate.	<ol style="list-style-type: none"> 1. Check if the Main Brush is stuck by some foreign objects; if yes, please remove them and clean the brush. 2. Check if the Main Brush and brush guard have been installed properly.
Side Brush does not rotate.	<ol style="list-style-type: none"> 1. Check if the Side Brush is stuck by some foreign objects; if yes, please remove them and clean the brush. 2. Check if Brush Guard trap the Bristles of Side Brush. 3. Check if the Side Brush have been installed properly.

<p>Robot movements or travel path are abnormal.</p>	<ol style="list-style-type: none"> 1.Clean the sensors carefully with a dry cloth. 2.Check wheels, side brushes and Main Brush if have foreign objects on them; if yes, please remove foreign objects. 3.If you still have trouble, turn off the robot,wait for 5 seconds and restart it.
<p>Robot cannot connect to a Wi-Fi network.</p>	<ol style="list-style-type: none"> 1.Please Put Robot near Wi-Fi Router 2.Make sure your mobile phone is connecting with 2.4GHz Wi-Fi. 3.If your router is 2.4GHz and 5GHz Dual band, please connect your mobile phone with 2.4GHz Wi-Fi. 4.In your router, if 2.4GHz and 5GHz Wi-Fi use same Wi-Fi name, please enter router control page to rename 2.4GHz and 5GHz Wi-Fi with different Wi-Fi name. Then make your mobile phone to connect with new 2.4GHz Wi-Fi. 5.Please make sure Bluetooth switch  on your mobile phone or tablet is ON. 6.Please reset Wi-Fi and download the latest TuyaSmart app to retry connecting. For details, refer to the "3.4.Connect Robot with Wi-Fi", page 11 in this manual
<p>In app, robot is shown offline.</p>	<ol style="list-style-type: none"> 1.Make sure robot has powered on. 2.Make sure Wi-Fi is connected successful, and Wi-Fi Status Light is solid blue. 3.Please reset Wi-Fi and download the latest mobile app to retry connecting, For details, refer to the "3.4.Connect Robot with Wi-Fi", page 11 in this manual.
<p>In app, real time cleaning Map is not my home layout.</p>	<p>Real time cleaning Map in app is just Map to show Robot cleaning track, so wouldn't be your home layout.</p>
<p>Once Robot is stopped or has error, after restart cleaning again, why cleaning map will re-draw as new? It wouldn't draw on last cleaning map.</p>	<p>Because each time after robot is stopped or fixing error , and restart cleaning again, robot place and direction will change a little. If draw on last cleaning map, will disorder cleaning map. So robot will re-draw new cleaning map after above condition.</p>
<p>You cannot control Robot with Amazon Alexa.</p>	<ol style="list-style-type: none"> 1.Check if there are any Internet connection problems. 2.Check if you have installed the Amazon Alexa app onto your smart device. 3.Make sure you have an TuyaSmart account and have connected to Robot successfully. 4.Make sure you have connect Alexa on TuyaSmart app, for detail please check "3.4.6.Work with Amazon Alexa or Google Assistant" on page 16. 5.Make sure you are using correct Alexa voice-commands which also listed in 3.4.6 on page 18.

<p>You cannot control Robot with the Google Assistant.</p>	<ol style="list-style-type: none"> 1. Check if there are any Internet connection problems. 2. Check whether you have installed the Google Home app onto your smart device. 3. Make sure you have an TuyaSmart account and have connected to Robot successfully. 4. Make sure you have connect Google assistant on TuyaSmart app , for detail please check "3.4.6 Work with Amazon Alexa or Google Assistant" on page 16. 5. Make sure you are using correct Google home voice-commands which also listed in 3.4.6 on page 18.
<p>No or little water during mopping.</p>	<ol style="list-style-type: none"> 1. Please check whether there is water in the water tank. 2. Please make sure that the water tank and mopping cloth are properly installed in place, and adjust the water volume switch to high on app. 3. For mopping function details, please check "3.11 Mopping the floor" page 22 in this manual.
<p>Too much water during mopping.</p>	<ol style="list-style-type: none"> 1. Please make sure that the water tank and mopping cloth are properly installed in place, and adjust the water volume switch to low in app. 2. For mopping function details, please check "3.11 Mopping the floor" page 22 in this manual.
<p>Do I need to charge the battery for at least 16 hours for the first three uses?</p>	<p>The lithium battery has no memory effect, so it's okay to just fully charge it.</p>

If above solution don't work, please contact support.us@tikom.cc for help.

5.3 Wi-Fi Connection

5.3.1 Wi-Fi Setup Requirement

Before Wi-Fi setup, make sure your mobile device, Robot and your Wi-Fi network meet the following requirements.

5.3.1.1 Mobile Device Requirement

Make sure your Smartphone or tablet is connected to a 2.4GHz Wi-Fi.
 Make sure Bluetooth switch  on your smartphone or tablet is ON.

5.3.1.2 Robot Requirement

1. The Wi-Fi Status Light on Robot is flashing blue for waiting for Wi-Fi connection.
2. Robot is attached to the Charging Station to ensure it has enough power during setup.

5.3.1.3 Wi-Fi Requirement

1. Make sure the robot and your mobile device are close to the router when connection.
2. Make sure you've entered the correct Wi-Fi name and password when connecting.
3. Avoid using an emoji or special characters or symbols in your Wi-Fi name and password.
4. It's not recommended to use a VPN (Virtual Private Network) or Proxy Server.
5. If your router is 2.4GHz and 5GHz Dual band, please connect your mobile phone with 2.4GHz Wi-Fi.

In your router, if 2.4GHz and 5GHz Wi-Fi use same Wi-Fi name, please enter router control page to rename 2.4GHz and 5GHz Wi-Fi with different Wi-Fi name. Then make your mobile phone to connect with new 2.4GHz Wi-Fi.

6. When connecting to a hidden network, make sure you enter the correct network name, SSID (case sensitive), and connecting to a 2.4GHz wireless network.
7. When using a network extender/repeater, make sure the network name (SSID) and password are the same as your primary network.
8. Your Wi-Fi router supports 802.11b/g/n and IPv4 protocol.
9. WPA and WPA2 using TKIP, PSK, AES/CCMP encryption.
10. WEP EAP (Enterprise Authentication Protocol) is not supported.
11. Use Wi-Fi channels 1-11 in North America and channels 1-13 outside North America (refer to local regulatory agency).

5.3.2 Wi-Fi Connection troubleshooting

If you cannot control Robot with your smart device, try the solutions below to solve the problem.

Wi-Fi Status Light	Voice Prompt	Cause
Flash Blue	Wi-Fi Connected	1.Robot has connected to your router, but cannot access the Internet. 2.app Serve has problem.
Solution		
1.Check if your router is connected to the Internet. Check with your Internet provider to see if there is any Internet connection problem. 2.Wait several hours, to check app control again to check if app server is ok.		

Wi-Fi Status Light	Voice Prompt	Cause
Flash Blue	/	1.Robot cannot connect to your wireless router. 2.Wi-Fi connection is reset or has not been set up before.
Solution		
1.Please Put Robot near Wi-Fi Router 2.Make sure your mobile phone is connecting with 2.4GHz Wi-Fi. 3.If your router is 2.4GHz and 5GHz Dual band, please connect your mobile phone with 2.4GHz Wi-Fi. 4.In your router, if 2.4GHz and 5GHz Wi-Fi use same Wi-Fi name, please enter router control page to rename 2.4GHz and 5GHz Wi-Fi with different Wi-Fi name. Then make your mobile phone to connect with new 2.4GHz Wi-Fi. 5.Please make sure Bluetooth switch  on your mobile phone or tablet is ON. 6.Please reset Wi-Fi and download the latest TuyaSmart app to retry connecting. For details, refer to the "3.4.Connect Robot with Wi-Fi", page 11 in this manual		

Wi-Fi Status Light	Voice Prompt	Cause
Off	/	1.Robot is turned off. 2.Robot power level is low. 3.Robot is in Sleep Mode.
Solution		
1.Fully charge Robot by attaching it to the Charging station. 2.After fully charged, Power on robot to recheck.		

If above solution don't work, please contact support.us@tikom.cc for help.

6.Specifications

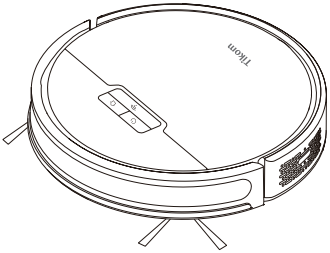
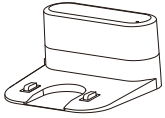
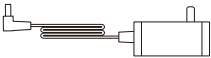
	Model No	G8000
	Navigation	Gyroscope
	Suction Power	2700Pa
	Dust Bin Capacity	450ml
	Water Tank Capacity	250ml
	Battery	DC 14.4V 2600mAh
	Suction Time	After Full Charged Gentle: About 120mins Normal: About 90mins Strong: About 60mins Will change after usage
	Mopping Time	Water Tank is Full Low: About 110mins Middle: About 80mins High: About 60mins
Size	Φ320*76 mm	
	Power Input/Output	DC 19V 0.6A
	Station Size	147*142*81mm
	Power Input	AC 100-240V~ 50/60Hz 0.4A max
	Power Output	DC 19V 0.6A

7. Customer Service

For FAQs and more information, please visit www.tikom.cc.

✉ Email: support.us@tikom.cc

We also update many robot troubleshooting video and maintenance video onto our Youtube channel.

You could search "Tikom Technology" in Youtube to find our channel.

Tikom



@TikomOfficial



@TikomOfficial



@TikomOfficial



@TikomOfficial

Manufacturer: Shenzhen Tikom Technology & Innovation Co.,LTD

Address: 217, C Building, Chengshishanhai Center, Bantian, Longgang District, Shenzhen, Guangdong, China

Website: www.tikom.cc
Email: support.us@tikom.cc