



User Manual

T10

Important Safety Instructions

To reduce the risk of injury or damage, keep these safety precautions in mind when setting up, using and maintaining your robot vacuum cleaner:

- Read all safety and operating instructions before operating your robot.
- Retain the safety and operating instructions for future reference.
- Pay attention to all warnings on your robot, battery, charging dock and in the user manual.
- Follow all operating instructions.
- The external cable or cord of the power supply unit can not be replaced; if the cord or plug is damaged, the power supply unit shall be disposed of.
- This product is designed to be plugged into a standard outlet only. Product may not be used with any type of power converter. Use of power converters will immediately void the warranty.
- Please charge and remove the battery from your robot and accessories before long-term storage or transportation.
- The battery must be removed from this device before this device is disposed of. To remove the battery from this device, first remove the screws on the bottom, then remove the main PCB and unscrew the battery cover by using a screwdriver. Remove the battery by disconnecting the quick connector.
- **WARNING: Chemical Exposure:** If the battery pack is leaking, do not allow the liquid to come in contact with skin or eyes. If contact has been made, wash the affected area with copious amounts of water and seek medical advice. Place the battery (the used battery pack included when the robot will be disposed) in a sealed plastic bag and dispose of safely according to local environmental regulation.
- **WARNING: Fire or Explosion Hazard:** Do not crush or dismantle battery packs. Do not heat or place the battery pack near any heat source or direct sunlight. Do not incinerate or short-circuit the battery pack. Do not subject batteries to mechanical shock.
- Contact your local waste management authority for battery recycling and disposal regulations in your area.
- Your robot is not a toy. Do not sit or stand on robot. Children and pets should be supervised when your robot is operating.
- Robot is for indoor use only.
- Do not use non-rechargeable batteries. Use the rechargeable battery provided with the product only. For replacement, purchase identical robot batteries or contact robot Customer Care for alternative battery options.
- Store and operate the robot in a room with moderate temperatures only.
- Do not spray or pour liquids on your Robot.
- Do not use any other power supply cord. For replacement cords, please contact Customer Care to ensure proper selection of country-specific power supply cord.
- Do not use the robot to pick up sharp objects, glass, or anything that is burning or smoking
- Do not immerse the battery pack in any liquid.
- Do not use the robot to pick up spills of water, bleach, paint, or other chemicals, or anything wet.

- Picking up objects like clothing, loose papers, pull cords for blinds or curtains, power cords, and any fragile objects before using the robot. If the robot passes over a power cord and drags it, objects on table or shelves are likely to fall off.
- If the room to be cleaned contains a balcony, a physical barrier should be used to prevent access to the balcony and ensure safe operation.
- Do not place anything on top of your robot.
- Be aware that the robot moves on its own. Take care when walking in the area that the robot is operating in to avoid stepping on it.
- Do not operate the robot in areas with exposed electrical outlets on the floor.
- Do not use this device on an unfinished, unsealed, waxed or rough floor. It may cause damage to the floor and this device. Use only on hard floor surfaces or low pile carpets.
- This device has been designed to be used on floors without scratching them. We still recommend that you test this device on a small area of the room to be cleaned to ensure no scratches are made before cleaning the whole room.

Battery and Charging Information

Lithium-ion Battery

Important: Lithium-ion batteries and products that contain Lithium-ion are subject to stringent transportation regulations. If you need to ship this product (with the battery included) for service, travel or any other reason, you **MUST** comply with the following shipping instructions:

- Remove the Lithium-ion battery from the product.
- Place a piece of tape over the battery's metal charging contacts.
- Reinstall the battery (with the tape on it) in the product and secure the battery door.
- Package the product in its original packaging or in your own packaging that prevents any movement during transportation.
- Ship via ground transportation only (no air shipping).

Battery Storage

If storing robot off the charging dock, remove the battery first. Then store robot and the battery in a cool, dry place.

 The symbol on the product or its packaging indicates: Do not dispose of electrical appliances as unsorted municipal waste, use separate collection facilities. Contact your local authority for information regarding the collection systems available. If electrical appliances are disposed of in landfills or dumps, hazardous substances can leak into the groundwater and get into the food chain, damaging your health and well-being. Please contact your local or regional waste authority for more information on collection, reuse and recycling programs.

FCC Statement

This device complies with Part 15 of the FCC Rules. Operation is subject to the following two conditions: (1) This device may not cause harmful interference, and (2) this device must accept any interference received, including interference that may cause undesired operation.

Warning: Changes or modifications not expressly approved by the party responsible for compliance could void the user's authority to operate the equipment.

Note: This equipment has been tested and found to comply with the limits for a Class B digital device, pursuant to Part 15 of the FCC Rules. These limits are designed to provide reasonable protection against harmful interference in a residential installation. This equipment generates, uses, and can radiate radio frequency energy and, if not installed and used in accordance with the instructions, may cause harmful interference to radio communications. However, there is no guarantee that interference will not occur in a particular installation. If this equipment does cause harmful interference to radio or television reception, which can be determined by turning the equipment off and on, the user is encouraged to try to correct the interference by one or more of the following measures: (1) Reorient or relocate the receiving antenna. (2) Increase the separation between the equipment and receiver. (3) Connect the equipment into an outlet on a circuit different from that to which the receiver is connected. (4) Consult the dealer or an experienced radio/ TV technician for help.

Declaration of Conformity

This product complies with the radio interference requirements of the European Community. Hereby, we declare that the radio equipment type T2253 is in compliance with Directive 2014/53/EU.

Trademark Notice

- Amazon, Echo, Alexa and all related logos are trademarks of Amazon.com, Inc. or its affiliates.
- Apple and the Apple logo are trademarks of Apple Inc., registered in the U.S. and other countries. App Store is a service mark of Apple Inc., registered in the U.S. and other countries.
- Google Play and the Google Play logo are trademarks of Google Inc.
- Google Home is a trademark of Google Inc.

About Your Robot

1. What's in the Box



1 x Robot Vacuum T10

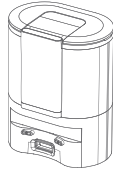

1 x Auto Empty Base



1 x Remote Control with Batteries



1 x Cleaning Brush



1 x Spare Washable Mop

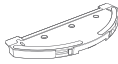

1 x Mop attachment



1 x Spare Side Brush

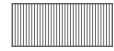

1 x Spare HEPA Filter with Sponge



2 x Spare Dust Bag



1 x Quick Start Guide



1 x APP User Guide



1 x User Manual

2. Product Overview

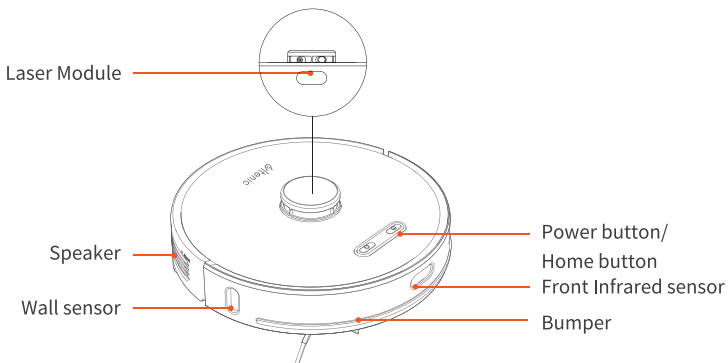

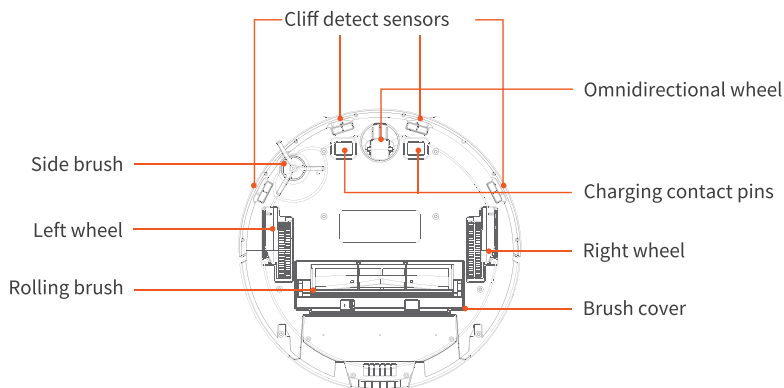
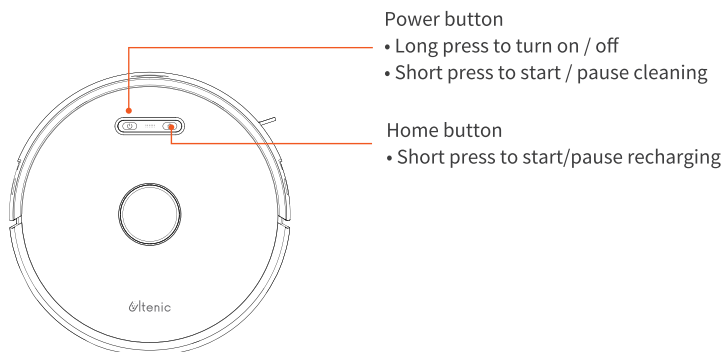
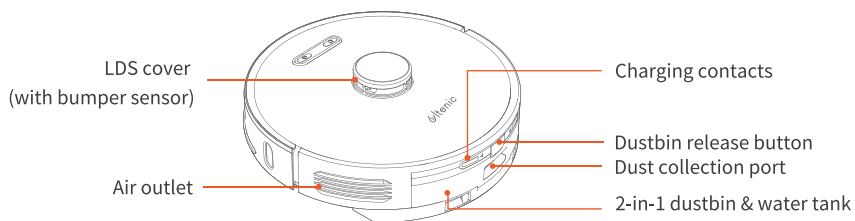

🔌 🏠 LED indicator

- Flashing blue light: Powering on/configuring network/upgrading firmware
- Solid blue light: Powered on/normal working state
- Flashing yellow light: Low battery/recharging
- Flashing green light: Charging
- Solid green light: Fully charged
- Flashing red light: Error state
- Light off: Power off/sleeping

3. Dustbin & Water Tank

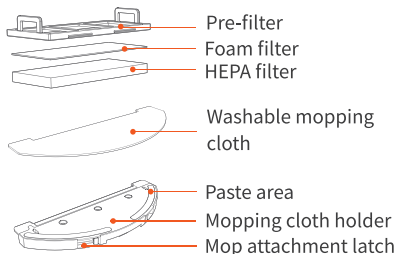
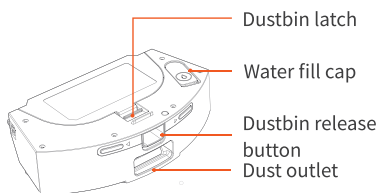

4. Auto Empty Base

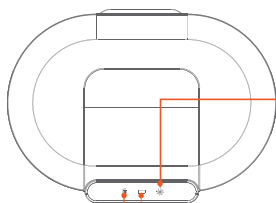
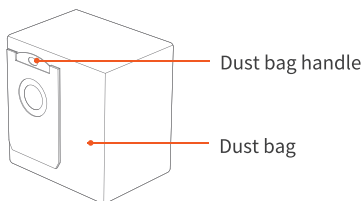
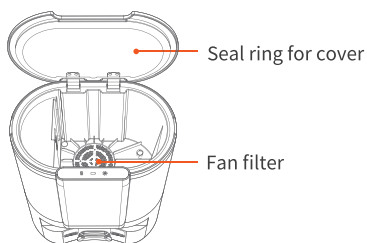
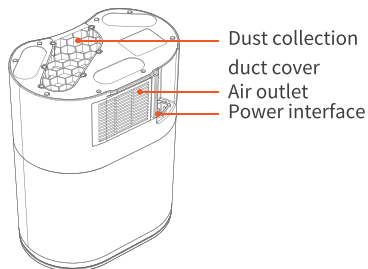
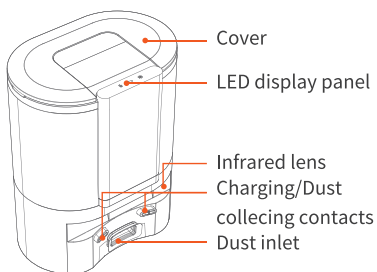

- Status Indicator
 - Solid green light: Collecting dust
 - Flashing red light: Fan overheating/fan error/cover not closed
- Power Indicator
 - Flashing green light: Charging
 - Solid green light: Fully charged/standby
- Dust Bag Indicator
 - Solid green light: Dust bag is full/dust duct is blocked
 - Flashing red light: Dust bag is not installed /dust bag is not installed correctly

5. Remote control

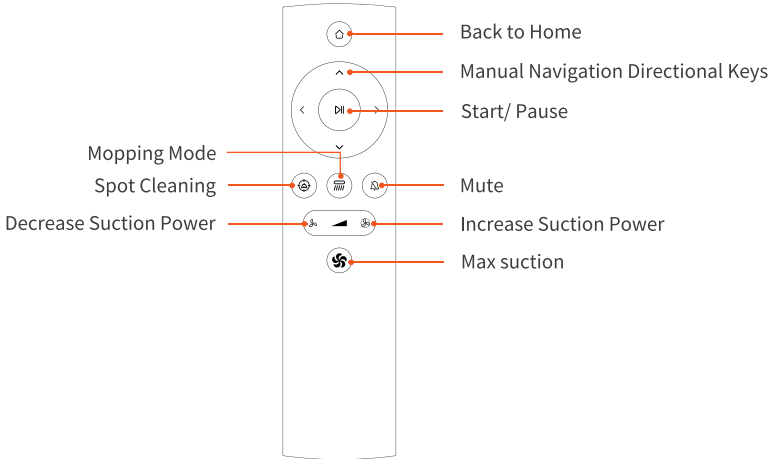

! Note:

1. It is recommended to point the remote to the front of the Robot for best results.
2. The remote control range is 3-6 meters (10-20 feet).

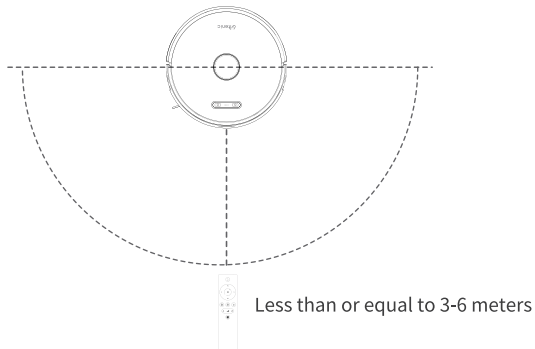

Using Your Robot

1. Setting up the Auto Empty Base

About your Auto Empty Base

The Auto Empty Base is designed to automatically empty and charge the Ultenic robot vacuum cleaner T10. Plug the power cable into the back panel of the Base and plug the other end in a functioning wall outlet. Place on a flat, hard surface at least 2.5 inches away from the wall. Ensure that there is a clear space in front and both sides so that your T10 can return to Base to recharge and empty.

How to place your Auto Empty Base

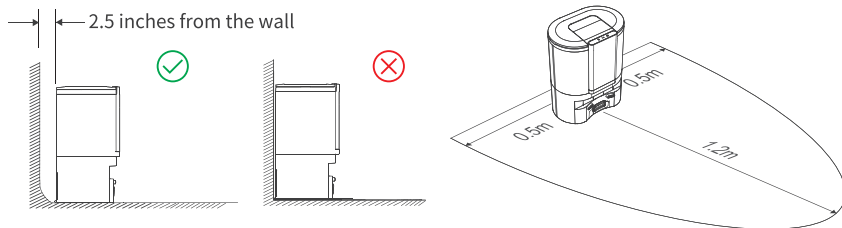

! Note:

1. Place the Auto Empty Base where the robot can easily access.
2. The Auto Empty Base must always remain connected to power. Avoid using a power source that may inadvertently be switched off.

2. Setting up the Robot

Step 1:

Position the Robot on the floor near your Auto Empty Base. Press and hold the “⏻” Power button until the indicator turns blue. You will hear a welcome message.

! Note:

Voice prompt volume can be adjusted later in the Ultenic App or muted using the remote control.

Step 2:

Press the “🏠” Home button to pair the Robot to your Auto Empty Base. The Robot will navigate and dock to the base. Allow the Robot to fully charge before first use.

! Note:

Dust collection may activate during initial docking. Do not be alarmed. Dust collection frequency can be adjusted later in the Ultenic App.

3. Getting Started

Before using this product, please clear the floor of all objects other than furniture as some small objects may obstruct, get caught in, or damage your Robot.

Use Your Robot with the Ultenic App

To fully enjoy all the available features, it is recommended to control your Robot via the Ultenic app.

Before you start, make sure that:

- Your smartphone or tablet is connected to a Wi-Fi network.
- Your smartphone or tablet is running iOS 8.0 (or above) or Android 4.4 (or above).
- The 2.4GHz band wireless signal is enabled on your wireless router.



1. Download the Ultenic app from the App Store (iOS devices) or Google Play (Android devices).
2. Open the app and create a user account.
3. Tap the “+” icon to add the Robot T10 to your Ultenic account.
4. Follow the instructions in the app to set up the Wi-Fi connection.

After connecting successfully, you can control your Robot via the app. With the app, you can select cleaning at your desired suction level, schedule cleaning, view the cleaning map, set up “No-Mop” or “No-Go” zones, set up dust empty frequency, check the network connection status, and access additional features.

First Cleaning and Home Mapping

After the first Auto-clean cycle the Robot will create a virtual map of your home, viewable in the Ultenic app. Using that map you can define Areas and set Virtual Boundaries. Those Areas and Boundaries can then be used in any of your cleaning cycles and schedules (eg avoid the “Baby Room” during a daytime clean, mop ONLY the “Kitchen”).

Use the included remote control, or the Ultenic APP to control your preferred cleaning method. Once you have chosen your preferred cleaning method, the Robot will start cleaning and will continue until it has covered the entire cleaning area, or until the battery is low and needs to be re-charged. Once cleaning is finished, the Robot will automatically return back to the Auto Empty Base to empty the dustbin. If a cleaning session was interrupted due to low battery, it will automatically resume cleaning once the power has been sufficiently restored.

Cleaning Modes

Auto Clean - The Robot will automatically clean your floor until it has covered the entire surface. Once cleaning is finished or the battery needs to be re-charged, the Robot will automatically return back to the Auto Empty Base to empty the Robot's dustbin and charge or resume cleaning.

Area Clean - Create customizable areas on your floor-plan within the Ultenic App for your Robot to specifically clean or avoid.

Spot Clean - The Robot will focus on a specific spot you desire to have cleaned thoroughly. First, use the manual navigation control on the remote (or in the app) to guide the Robot to the desired area. Then, choose Spot Clean mode.

Mopping - Attach the water tank attachment to the dustbin from the rear of the Robot. Choose Mopping mode in the Ultenic App or the included remote and the Robot will automatically mop the surface and return to the Auto Empty Base once complete.

Manual Control - Using the Ultenic App or the included remote, you can manually control where the Robot goes.

Maintenance and Care

Your Robot is designed to be used regularly. As with most floor care devices, regular use may cause build-up around brushes, in debris compartments and near filters. We recommend performing regular maintenance, as outlined in the following pages, to keep your Robot running at optimal performance.

1. Recommended Care/ Replacement Frequency

PART	CARE FREQUENCY	REPLACEMENT FREQUENCY
Rolling brush	Once per week	Every 6-12 months
Side brush	Once per week	Every 3-6 months
Filters	Once per week	Every 2 months
Sensors	Once per month	—
Charging contacts	Once per month	—
Omnidirectional wheel	Once per month	—

2. Maintaining Side Brush

- 1 Use a Philips screwdriver to unscrew the side brush screw and remove the side brush.

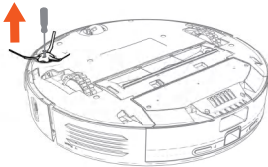

- 2 Remove dirt and debris and reinstall using Philips screwdriver.

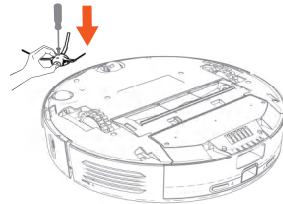

! Note:

It is recommended to replace the side brush every 3-6 months depending on use.

3. Maintaining Rolling Brush

- 1 Pinch the left and right tabs on the rolling brush cover. Lift and remove the cover.

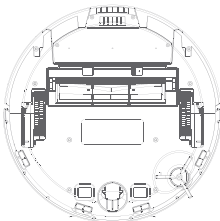

- 2 Remove the main brush and clean with included cleaning tool as seen in the figure below.

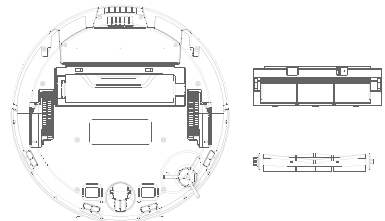

- 3 Replace the main brush and snap the cover back into place.

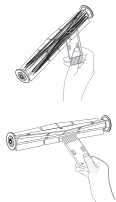

Note:

It is recommended to replace the main brush every 6-12 months depending on use.

4. Maintaining the Dustbin/ Water Tank

- 1 Press the dust bin release button and remove the dust bin.

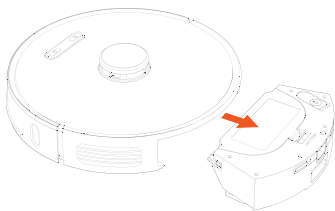

- 2 Open the dust bin and empty contents.

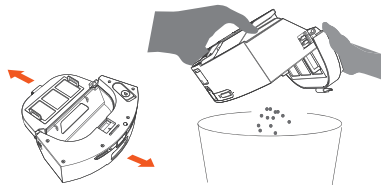

- 3 Remove the primary filter and HEPA filter, wipe down the surface with a dry cloth or use the cleaning tool. Rinse the primary filter with water and let dry.

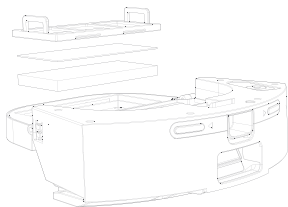

- 4 Remove the mop pad to wash and dry in the sun.

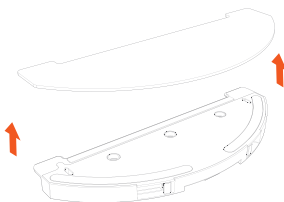

- 5 Pour out the remaining water in the water tank and dry the water tank.

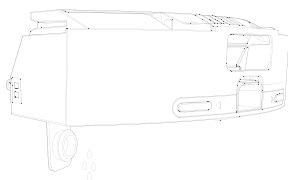

- 6 After the filter, dust box, mop cloth and water tank are all dried, put them back together for next use.

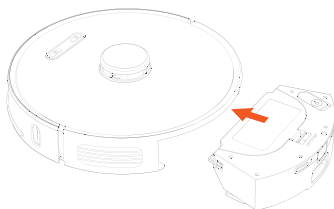

5. Maintaining Sensors, Charging Contacts and Omnidirectional Wheel

- 1 Use a damp cloth to clean all sensors on the Robot.

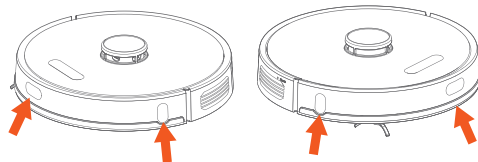
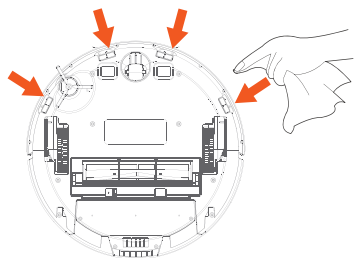

- 2 Use a dry cloth to clean the charging contacts on the Robot (alcohol is not recommended).

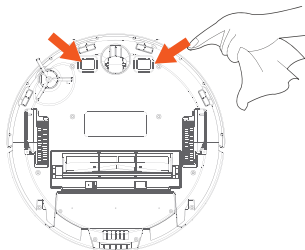

- 3 Remove any trapped hair or debris from the omnidirectional wheel with the cleaning brush provided.

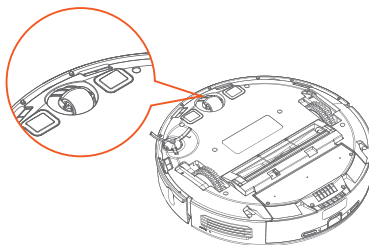

Note:

Do not clean the omnidirectional wheel with water.

6. Maintaining Auto Empty Base

Auto Empty Base Dust Bag

The Auto Empty Base will indicate when the dust bag is full on the smart LED display panel (Dust bag indicator “” will be green). Discard of dust bag once full and replace dust bag with a new one.

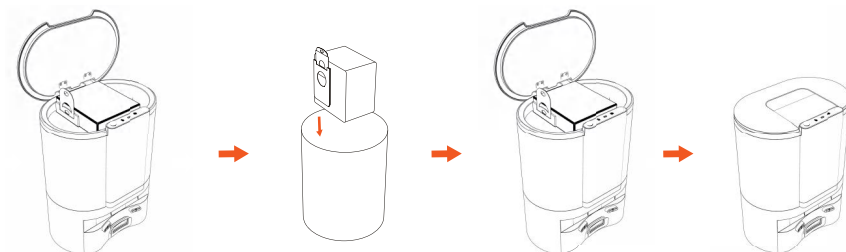



Open cover and pull up the dust bag from handle

Discard the old dust bag

Replace with new dust bag & fully lower cardboard handle

Close cover

Dust Duct and Filter

If the Auto Empty Base indicator light “” flashes or the “” is solid green, and the dust bag is not full, it is time to clean the filter and dust duct.

- 1 Use a Philips screwdriver to unscrew the side brush screw and remove the side brush. 2 Remove dirt and debris and reinstall using Philips screwdriver.
- 2 Open the exhaust at the rear of the Auto Empty Base, clean the filter, and reinstall.

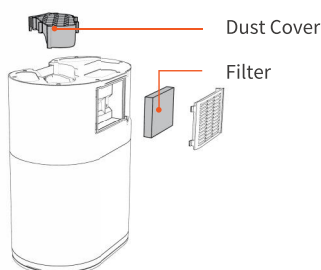

Fan Filter Support

Check if the fan filter support is contaminated by any debris and clean it with a dry cloth. It is recommended to clean it at least once a month.

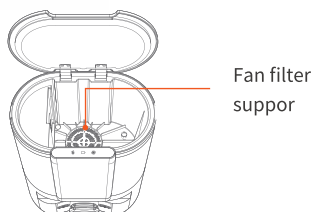

IR Lens and Charging/Dust Collecting Contacts

Check if the IR Lens and the Charging/Dust Collecting Contacts are contaminated and clean it with a dry cloth. It is recommended to clean it at least once a month.

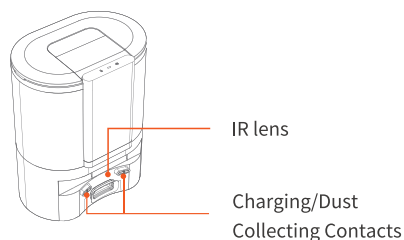





Specifications

Robot	Dimensions	φ350mmxφ350mmx98mm
	Product weight	≈3.6kg
	Rated voltage	14.4V
	Rated power	50W
	Battery capacity	5200mAh
Auto Empty Base	Dimensions	282mmx361mmx202mm
	Product weight	≈3.82kg
	Rated voltage	1050W
	Input Rating	100-240V ~50/60Hz
	Output Rating	DC24V≈1.2A

Troubleshooting

When your Robot encounters a problem, try the solutions below to solve the problem. If the problem persists, contact the Ultenic service center for help.

Problems	Solutions
Unable to power on/ start cleaning	Please charge before use. This is commonly caused due to low battery.
Unable to return to Auto Empty Base	<ul style="list-style-type: none"> • Make sure the Auto Empty Base is connected to a power source. • Check if there are too many obstacles near the Auto Empty Base. Please put the base in an open area. • The Robot is out of range of the Auto Empty Base. Move the Robot closer to the Auto Empty Base to re-establish connection. • Check if the battery level is critically low or empty. • It is recommended to control the robot back to the dust emptying base before the first cleaning to let the robot memorize the starting point.
Abnormal noise during cleaning	Please check if the main brush, side brush or left/right wheel are tangled with any objects. If there is an obstruction clear it and restart the Robot.
Decrease in cleaning ability or dust falling out from dustbin	<ul style="list-style-type: none"> • The dustbin is full, please empty the dustbin. • Check and clean the HEPA filter. • Check that the brush is clear from obstruction.
Robot's movements or travel path are abnormal	<ul style="list-style-type: none"> • Clean the sensors carefully with a dry cloth. • Restart the Robot by turning it off and on.
Unable to connect to WiFi	<ul style="list-style-type: none"> • Make sure you've entered the right password. • Keep the robot, mobile device and your router being as close as possible. • Make sure you selected a 2.4GHz WiFi. • It's not recommended to use public network. • Long press  and  simultaneously for 5 seconds to reset the robot WiFi, then try again. • Reinstall the Ultenic App and try to connect to WiFi again.
Unable to charge after docking	Make sure there is no obstruction or heavy dust on both the Robot and Auto Empty Base charging contacts.
Water is not released during mopping	<ul style="list-style-type: none"> • Make sure there is enough water in the water tank. • Check if the mopping attachment is correctly installed. • Check if the water outlets are blocked.
The remote doesn't work.	<ul style="list-style-type: none"> • Make sure that the batteries in the remote have power. • Make sure you have powered on the robot. • Check if the battery level is critically low or empty. • Check if the distance between the Robot and remote within the effective range (3m/9.84ft).
The auto empty base doesn't collect the dust.	<ul style="list-style-type: none"> • Check if the dust bag is full and replace it with a new one • Check if the dust bag is properly installed. • Check if you have set up not to automatically empty after cleaning in Ultenic App.

Indicator	Definition	Solution
 Flashing red	<ul style="list-style-type: none"> • Fan error • Overheating • The cover is not closed properly 	<ol style="list-style-type: none"> 1. Frequent dust collection leads to fan overheating protection or fan malfunction. It is recommended to try to collect dust after 30 minutes. 2. Ensure that the cover of the Auto Empty Base is completely closed.
 Flashing red	The dust bag is not installed or installed properly	<ol style="list-style-type: none"> 1. Check whether the dust bag is installed, if not, please install the dust bag. 2. Ensure that the dust bag is properly installed and fully lower the cardboard handle.

After-Sale Service

The professional customer service team from Ultenic will be responsible and provide support to all products that come with a worry-free warranty for one year automatically after purchase.

Please contact Ultenic Support and Service via Email below.

United States	service-us@ultenic.com
Deutschland	service-de@ultenic.com
France	service-fr@ultenic.com
España	service-es@ultenic.com
Canada	service-ca@ultenic.com
United Kingdom	service-uk@ultenic.com
Italia	service-it@ultenic.com
日本	service-jp@ultenic.com

Customer Service

United States	service-us@ultenic.com
Deutschland	service-de@ultenic.com
France	service-fr@ultenic.com
España	service-es@ultenic.com
Canada	service-ca@ultenic.com
United Kingdom	service-uk@ultenic.com
Italia	service-it@ultenic.com
日本	service-jp@ultenic.com



www.ultenic.com



Ultenic_Official



ultenic__official



UltenicOfficial



Ultenic_Official