

# Sliding Gate Opener User Manual

SGO-0000-01 1400 lb. Complete Kit

SGO-EC06-02 1400 lb. Essentials Kit

SGO-1801-GY 1800 lb. Home Use Kit

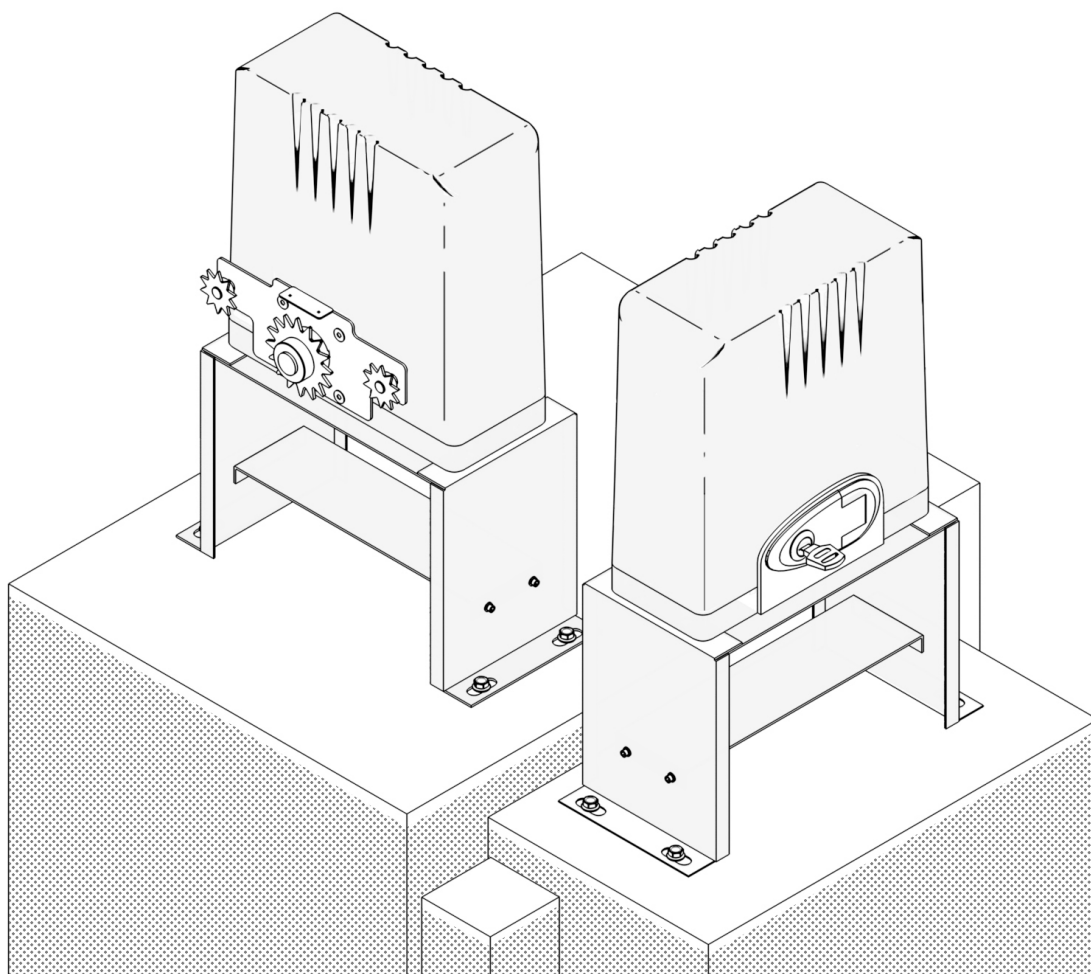

Read Carefully Before Use  
Keep for Future Reference



# PLEASE READ THIS FIRST

Thank you for purchasing our sliding gate opener.

This manual only applies to the following CO-Z® products.

Name	Model
Sliding Gate Opener 1400 lb.	SGO-0000-01
Sliding Gate Opener 1400 lb. Essentials Kit	SGO-EC06-02
Sliding Gate Opener 1800 lb. Home Use Kit	SGO-1801-GY

This manual provides the knowledge needed to safely and efficiently operate this product and manufacturer-licensed accessories. Contact customer service if you have any questions.

Read this manual carefully before installation and use. Follow this manual completely, paying particular attention to safety instructions. Failure to do so may cause serious personal injury and product damage.

This product was exclusively designed and manufactured for the use specified in this manual. Any use not specified herein could potentially damage the product and pose risks. Incorrect installation or improper use of the product may result in harm to individuals, animals, or property.

This manual describes the configurations, options, and accessories of this product.



This manual contains crucial specifications, precautions, and troubleshooting information necessary to ensure safe and effective use of this product. Keep this manual in an easily accessible location and store it securely.

# Audience

This manual is intended for adult readers who are capable of independent behavior and autonomy and who possess a basic awareness of mechanical and electrical safety precautions. Users must be fully aware of the mechanical and electrical risks that may be involved in the installation and use of such products before use.

## Symbol Guide

The following symbols are used in this manual:

Symbol	Meaning
 <b>Warning</b>	Precautions to prevent serious property damage or personal injury
 <b>Caution</b>	Precautions to prevent damage to equipment and facilities
 <b>Note</b>	Crucial information that can contribute to safer and more efficient usage

# FOR YOUR RECORDS

You can record the following information for future reference in case you require service for your automatic gate opener.

Model: \_\_\_\_\_

Date of Purchase: \_\_\_\_\_

Place of Purchase: \_\_\_\_\_

# Contents

<b>1. General Safety Information</b>	<b>1</b>
<b>2. Product Description</b>	<b>2</b>
2.1 Specifications	2
SGO-0000-01	3
SGO-EC06-02	5
SGO-1801-GY	7
2.2 Package List	9
Main Components	9
Base Components	9
Chain Support Components	10
Magnetic Limit Switch Components	11
Infrared Sensor (SGO-1801-GY Only)	11
Optional Accessories for Function Expansion	12
<b>3. Preparation</b>	<b>13</b>
3.1 Definition of Sliding Direction	13
3.2 Check Installation Conditions	14
3.3 Customize Your Installation	14
3.4 Prepare Components and Tools	15
<b>4. Install Safety Guards</b>	<b>16</b>
<b>5. Mechanical Installation</b>	<b>17</b>
5.1 Safety Precautions	17
5.2 Base Component Assembly	18
5.3 Base-Main Unit Connection	18
5.4 Chain Installation	19
5.5 Chain Test	24
5.6 Chain Box Cover Reinstallation	24
<b>6. Electrical Component Installation</b>	<b>25</b>
6.1 Important Information	25
6.2 Circuit Connection Methods	25
6.3 Control Board Description	26
Overview	26
Indicator Lights	27
Control Buttons	28
Digital Display	28
Interfaces	29

6.4 System Powering.....	30
6.5 Direction Reversal .....	30
6.6 Limit Switch Magnets.....	31
6.7 Fixation.....	32
6.8 Infrared Equipment Connection (SGO-1801-GY Only) .....	34
6.9 Wire Connection Guidance of Optional Accessories .....	35
Warning Light .....	35
Push Button.....	35
Swipe Card, Digital Keypad, and Other External Devices.....	35
Loop Detector.....	36
<b>7. Operation.....</b>	<b>37</b>
7.1 Remote Control Description .....	37
7.2 Functions .....	37
Movement Limitation .....	37
Mechanical Obstruction Feedback .....	37
Infrared Obstruction Feedback.....	38
Automatic Closing.....	38
Pedestrian Mode .....	38
Vehicle Detection.....	38
Travel Learning.....	38
Motor Running Protection.....	39
Manual Mode.....	39
7.3 Code Display .....	39
7.4 Basic Function Configuration.....	40
Accessing the Setting Menus .....	40
Selecting Menus and Adjusting Values.....	40
Confirming Selections and Saving Changes .....	40
Exiting the Setting Menus.....	40
7.5 Advanced Function Configuration.....	40
Learning Codes (Remote Control Learning).....	40
Clearing Codes.....	40
Travel Learning.....	41
Parameter Adjustment.....	41
<b>8. Troubleshooting .....</b>	<b>43</b>
<b>9. Maintenance.....</b>	<b>46</b>
<b>10. Disposal.....</b>	<b>48</b>
<b>11. Contact Information.....</b>	<b>48</b>

# 1. General Safety Information

Read the following information carefully before installation and use. This section provides general safety precautions. For particular precautions, consult the dedicated operation instructions related to those tasks.



## Warning

- Any actions or elements not explicitly covered in these instructions are strictly prohibited.
- **ALWAYS** keep bystanders, pets, and any objects away from the automation operation area.
- **NEVER** cross the path of the gate while it is in motion. Even driving through when it is closing remains **EXTREMELY** dangerous.
- **NEVER** let children operate or play with the gate controls and keep control devices out of the reach of children to prevent unintentional automation activation.
- **DO NOT** initiate the gate opener unless you have a clear line of sight and can confirm that its pathway is clear of people, pets, or other obstructions. Maintain constant vigilance over the gate's entire range of motion.
- **NEVER** modify the automation components without explicit authorization from the factory. **NEVER** attempt to perform repairs on the automation system. **NEVER** replace any components with nonidentical ones. Making modifications or adding components by personnel without proper training or involving unauthorized parts will void the manufacturer's warranty. Seek professional assistance from qualified technicians if needed.
- Maintain the gate opener as instructed herein. **ALWAYS** unplug the gate opener before performing any inspection, servicing, or maintenance.



## Caution

- Dispose of the packing materials (incl. plastic, cardboard, polystyrene, etc.) in accordance with local and national laws and regulations.
- Keep nylon or polystyrene bags out of the reach of children.

## 2. Product Description

Designed for installation on a slide-to-open single leaf gate, this opener system autonomously manages gate control for seamless vehicle entry and exit from your property. This operator accommodates a range of accessories, which are outlined in **Optional Accessories** below. Equipped with a safety feature, this operator halts and reverses gate movement upon encountering an obstruction. Additionally, an adjustable auto-close feature is included. The system boasts effortless installation and setup, requiring minimal maintenance to ensure optimal performance.



This product is not intended for the containment of animals.

### **Warning**

### 2.1 Specifications

This manual covers the following three models of sliding gate openers. For accurate information, read the content corresponding to the model you have purchased.

## SGO-0000-01

## Main Unit

Input Voltage & Freq.	110 V AC 60 Hz
<b>Components</b>	
Motor Type	Alternating Current (AC)
Motor Coil Material	Copper
Brushed/Brushless Motor	Single-Phase Induction Motor
Rated Voltage	110 V AC
Rated Current	2.5 A
Rated Power	220 W
Torque	22 N·m
Motor Speed	1500 rpm
Gear Speed	62 rpm
Housing Material	Acrylonitrile Butadiene Styrene (ABS)
Motor Base Material	Cast Aluminum
Duty Cycle	S2, 20 min.
Noise Level	< 56 dB
<b>Gear Shaft</b>	
Gear Material	Steel
Turbine Material	Copper
Worm Material	Steel
<b>Gate Compatibility</b>	
Max. Width	40 ft. (12.2 m)
Max. Weight	1400 lb. (635 kg)
Sliding Speed	3.3 fpm (13 m/min.)
<b>Operational Environment</b>	
Ambient Temperature	-4 to 158°F (-20 to 70°C)
Weatherproof Rating	IP44
<b>Remote Control</b>	
System Capacity	120 Remotes
Frequency	433.92 MHz (Rolling Code)
Effective Range	54.7 yd. (50 m)
Gate Control Modes	Remote, Manual

## SGO-0000-01

## Functions

Motor	
Thermal Cutoff	Yes
Gate Operation	
Operating Time	60 sec.
Sliding Speed	Yes
Slow Start Time	No
Slow Stop Time	Yes
Obstacle Stop/Reversal	Opening: Obstacle Stop / Closing: Obstacle Reversal
Auto-Close Timer Range	0–99 sec.
Sliding Direction	Yes
Pedestrian Mode	Yes
Limit Switch Type	Magnetic Steel
Notification	
Opening/Closing	Digital Display Notification
Obstacle Reversal	Limit Return
Remote Control	
Button Configuration	Single-Button/Three-Button Control

## Size and Weight

Product Dimensions	14.2×11.2×18.7 in. (36×28×55.5 cm)
Product Net Weight (Including Accessories)	15.2 kg

## Accessories

Control Box Type	Built-in
Remote Control Quantity	2
Manual Key Quantity	2
Fuse Type	10 A
Chain Length	9.8 in. (3 m) ×2
Installation Accessories	Yes
Installation Accessory Material	Silver-Plated Zinc Steel

# SGO-EC06-02

## Main Unit

<b>Input Voltage &amp; Freq.</b>	110 V AC 60 Hz
<b>Components</b>	
<b>Motor Type</b>	Alternating Current (AC)
<b>Motor Coil Material</b>	Aluminum
<b>Brushed/Brushless Motor</b>	N/A
<b>Rated Voltage</b>	110 V AC
<b>Rated Current</b>	2 A
<b>Rated Power</b>	270 W
<b>Torque</b>	14 N·m
<b>Motor Speed</b>	1400 rpm
<b>Gear Speed</b>	54 rpm
<b>Housing Material</b>	Acrylonitrile Butadiene Styrene (ABS)
<b>Motor Base Material</b>	Cast Aluminum
<b>Duty Cycle</b>	S2, 20 min.
<b>Noise Level</b>	< 56 dB
<b>Gear Shaft</b>	
<b>Gear Material</b>	Steel
<b>Turbine Material</b>	Nylon
<b>Worm Material</b>	Steel
<b>Gate Compatibility</b>	
<b>Max. Width</b>	40 ft. (12.2 m)
<b>Max. Weight</b>	1400 lb. (635 kg)
<b>Sliding Speed</b>	3.3 fpm (13 m/min.)
<b>Operational Environment</b>	
<b>Ambient Temperature</b>	-4 to 158°F (-20 to 70°C)
<b>Weatherproof Rating</b>	IP44
<b>Remote Control</b>	
<b>System Capacity</b>	120 Remotes
<b>Frequency</b>	433.92 MHz (Rolling Code)
<b>Effective Range</b>	32.8 yd. (30 m)
<b>Gate Control Modes</b>	Remote, Manual

## SGO-EC06-02

### Functions

Motor	
Thermal Cutoff	Yes
Gate Operation	
Operating Time	60 sec.
Sliding Speed	Yes
Slow Start Time	No
Slow Stop Time	Yes
Obstacle Stop/Reversal	Opening: Obstacle Stop / Closing: Obstacle Reversal
Auto-Close Timer Range	0–99 sec.
Sliding Direction	Yes
Pedestrian Mode	Yes
Limit Switch Type	Magnetic Steel
Notification	
Opening/Closing	Digital Display Notification
Obstacle Reversal	Limit Return
Remote Control	
Button Configuration	N/A

### Size and Weight

Product Dimensions	14.2×11.2×18.7 in. (36×28.5×47.5 cm)
Product Net Weight (Including Accessories)	15.2 kg

### Accessories

Control Box Type	Built-in
Remote Control Quantity	2
Manual Key Quantity	2
Fuse Type	10 A
Chain Length	9.8 in. (3 m) ×2
Installation Accessories	Yes
Installation Accessory Material	Silver-Plated Zinc Steel

# SGO-1801-GY

## Main Unit

<b>Input Voltage &amp; Freq.</b>	110 V AC 60 Hz
<b>Components</b>	
<b>Motor Type</b>	Alternating Current (AC)
<b>Motor Coil Material</b>	Copper
<b>Brushed/Brushless Motor</b>	Single-Phase Induction Motor
<b>Rated Voltage</b>	110 V AC
<b>Rated Current</b>	2.8 A
<b>Rated Power</b>	180 W
<b>Torque</b>	26 N·m
<b>Motor Speed</b>	1500 rpm
<b>Gear Speed</b>	62 rpm
<b>Housing Material</b>	Acrylonitrile Butadiene Styrene (ABS)
<b>Motor Base Material</b>	Cast Aluminum
<b>Duty Cycle</b>	S2, 20 min.
<b>Noise Level</b>	< 56 dB
<b>Gear Shaft</b>	
<b>Gear Material</b>	Steel
<b>Turbine Material</b>	Copper
<b>Worm Material</b>	Steel
<b>Gate Compatibility</b>	
<b>Max. Width</b>	40 ft. (12.2 m)
<b>Max. Weight</b>	1800 lb. (816.5 kg)
<b>Sliding Speed</b>	3.3 fpm (13 m/min.)
<b>Operational Environment</b>	
<b>Ambient Temperature</b>	-4 to 158°F (-20 to 70°C)
<b>Weatherproof Rating</b>	IP44
<b>Remote Control</b>	
<b>System Capacity</b>	120 Remotes
<b>Frequency</b>	433.92 MHz (Rolling Code)
<b>Effective Range</b>	54.7 yd. (50 m)
<b>Gate Control Modes</b>	Remote, Manual

# SGO-1801-GY

## Functions

Motor	
Thermal Cutoff	Yes
Gate Operation	
Operating Time	60 sec.
Sliding Speed	Yes
Slow Start Time	No
Slow Stop Time	Yes
Obstacle Stop/Reversal	Opening: Obstacle Stop / Closing: Obstacle Reversal
Auto-Close Timer Range	0–99 sec.
Sliding Direction	Yes
Pedestrian Mode	Yes
Limit Switch Type	Magnetic Steel
Notification	
Opening/Closing	Digital Display Notification
Obstacle Reversal	Limit Return
Remote Control	
Button Configuration	Single-Button/Three-Button Control



## Size and Weight



Product Dimensions	14.2×11.2×18.7 in. (36×28.5×47.5 cm)
Product Net Weight (Including Accessories/Infrared Sensor)	15.25 kg

## Accessories

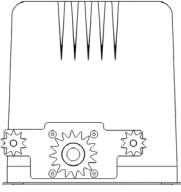
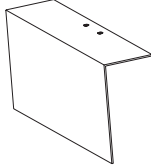

Control Box Type	Built-in
Remote Control Quantity	2
Manual Key Quantity	2
Fuse Type	10 A
Chain Length	9.8 in. (3 m) ×2
Installation Accessories	Yes
Installation Accessory Material	Silver-Plated Zinc Steel
Wired Infrared Sensors	1 Pair (2 Units)

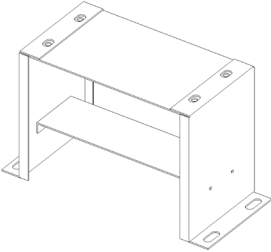
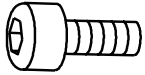
## 2.2 Package List



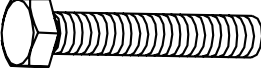

Main Components			
Item	Name	Qty.	Image
1	Main Unit	1	
2	Chain Box Cover	1	
3	Chains	2	
4	Manual Keys	2	

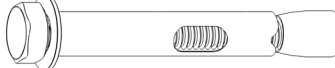
Base Components			
Item	Name	Qty.	Image
1	Base Frame	4-in-1	
2	M6×20 Hex Bolts	4	
3	M6 Hex Nuts	4	
4	M6 Spring Washers	4	



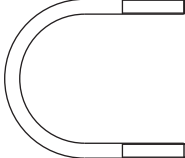
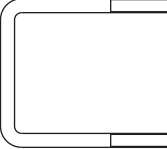

## Base Components (Continued)

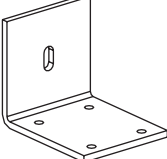
Item	Name	Qty.	Image
5	M6 Flat Washers	4	
6	M10×45 Hex Bolts	4	
7	M10 Flat Washers	4	
8	M10 Spring Washers	4	
9	M10×80 Anchor Bolts	4	

## Chain Support Components

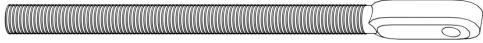
Item	Name	Qty.	Image
1	Arched U-Bolts	4	
2	Square U-Bolts	4	
3	M6 Hex Nuts	8	
4	M6 Flat Washers	8	
5	M6 Spring Washers	8	
6	Chain Brackets	2	

### Chain Support Components (Continued)

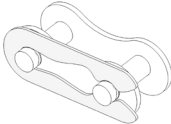
Item	Name	Qty.	Image
7	M8 Bolts	2	
8	M8 Hex Nuts	4	
9	M8 Flat Washers	4	
10	M8 Spring Washers	4	
11	Chain Joints	2	

### Magnetic Limit Switch Components

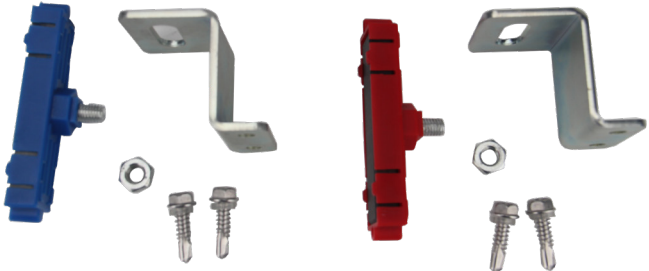
Name	Qty.	Image
Limit Switches (Incl. one M8 Nuts & two ST6×25 Screws)	2	

### Infrared Sensor (SGO-1801-GY Only)

Name	Qty.	Image
Infrared Sensor Set (Incl. Installation Accessories)	1	

## Optional Accessories for Function Expansion

- Warning Lights (Powered by AC)
- Push Button
- Swipe Card
- Digital Keypad
- Loop Detector (Ground Sensor)

**Warning**

Using components from other suppliers will void the manufacturer's responsibility in regard to the automation safety and proper operation.

## 3. Preparation

This chapter describes the preparation work that needs to be done before installation. Please carefully read and follow the instructions. Failure to do so may cause unsuccessful installation, shorten the lifespan of your gate, or even result in personal injury and property damage.



**Warning**

**NEVER** install this product in an explosive atmosphere.

### 3.1 Definition of Sliding Direction

Sliding direction herein refers to the direction in which your gate slides when you are facing the gate and standing at the side of your gate opener. This device is designated for immediate use with gates that slide open to the right. The installation procedures for gates that slide open to the left are basically the same as that for gates that slide open to the right, except for installation procedure with respect to the electrical part. Refer to Chapter 6 for details.

#### Right-Slide Opening

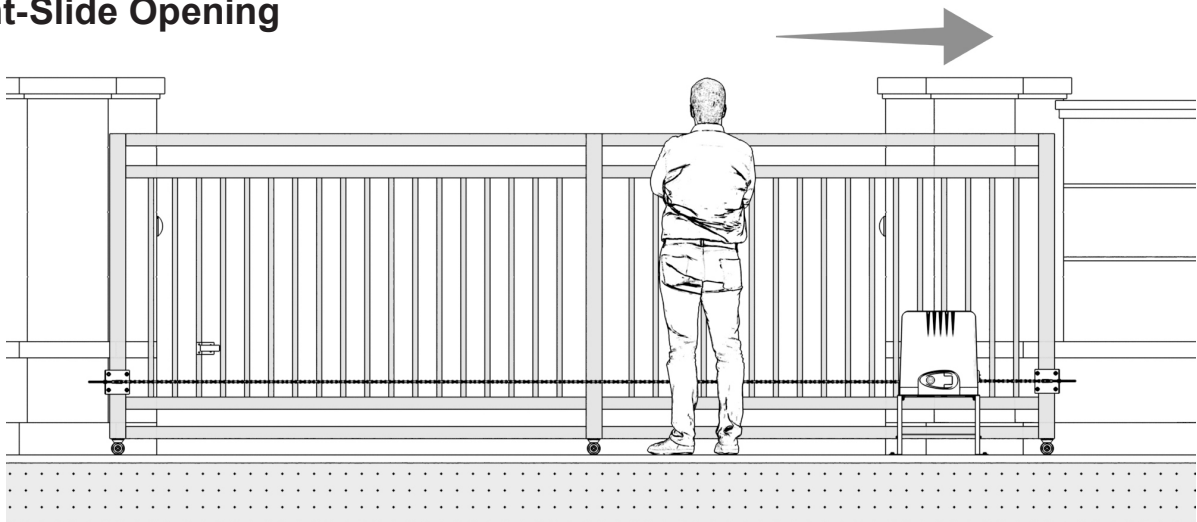

#### Left-Slide Opening

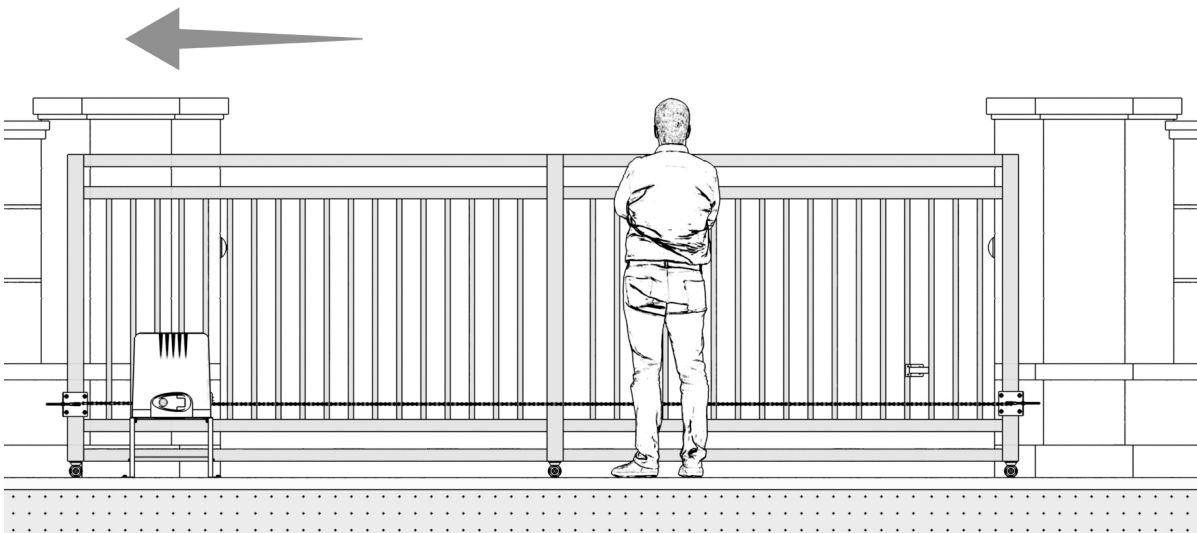

## 3.2 Check Installation Conditions

Before you start to install the gate opener, check to ensure that the installation conditions are appropriate.

- Ensure your gate fulfills Gate Compatibility in Specifications above.
- Ensure your gate's pillars are firmly secured to the ground with concrete, contributing to stability and reliability when in use.
- Ensure your gate was installed correctly and slides smoothly, without visible friction with its track or any risk of derailment throughout its movement.
- Ensure the bottom of your gate remains horizontal and its sides stay vertical during movement.
- Ensure sufficient space between your gate and its surrounding structures, posing no crushing or jamming risk during movement.
- Ensure no obstructions within the range of your gate's movement.
- Ensure proper protection against any exposed pinch points or prevent any pinch points from being exposed.



**Warning**

Using with improperly installed or unqualified gates, as well as any deformation on your gates occurring during use, will void the manufacturer's responsibility.

## 3.3 Customize Your Installation

Refer to the diagram below, which illustrates the result of the correct installation.

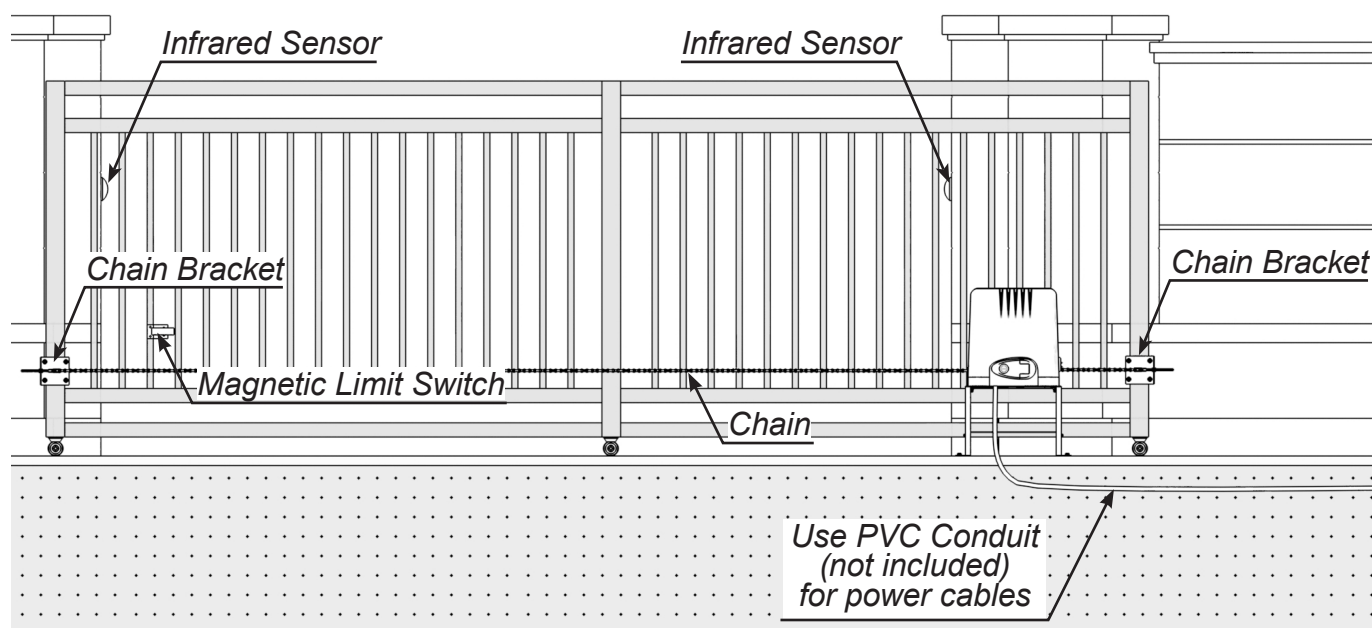

### The opener should:

- only be installed on the inside of your gate.
- not interfere with your vehicle access.
- be installed where it will not collide with the gate frame during movement, leaving at least 11.8 inches (30 cm) from any part.

The power line should be covered by PVC conduits (not included), and the external wiring should be buried underground to ensure safe use. Prepare a working power source nearby and arrange appropriate wiring routing. Select accessories necessary for your work.

## 3.4 Prepare Components and Tools

Check that all necessary accessories are intact and complete, preparing other helpful items as needed.

### Components Not Included but Necessary

- Double-Core Cable: 18 AWG (0.75 mm<sup>2</sup>), usu. 6.6 feet (2 m) long
- Conduits
- 3-Prong U.S. Plug
- Infrared Sensor Connection Cables: Single or double-core, usually 1.6 feet (0.5 m) long

### Tools Needed for Installation

- Spirit Level
- Adjustable Wrench
- Socket or Sleeve Kit
- Flathead Screwdriver
- Phillips Screwdriver
- Tape Measure
- Marker/Pencil
- Chainsaw/Hacksaw
- Hammer Drill
- Wire Cutters
- Wire Strippers

## 4. Install Safety Guards

For your safety, adapt following safety protection measures:

- Post at least two warning signs at prominent positions on both sides of your gate.
- Controls intended for user activation **MUST** be located at least 10 feet (3 m) away from any moving part of your gate and where the user is prevented from reaching over, under, around, or through the gate to operate the controls. Outdoor or easily accessible controls shall have a security feature to prevent unauthorized use.
- Exercise care to reduce the risk of nuisance tripping, such as when a vehicle trips the sensors while your gate is still moving in its opening direction.

# 5. Mechanical Installation

## 5.1 Safety Precautions



**Warning**

Put on appropriate personal protective equipment such as work gloves and be sure your gate is completely closed.



**Warning**

Be careful with any moving parts and avoid close proximity to areas where fingers or hands could be pinched.



**Warning**

**NEVER** install any control device where a user will be tempted to reach through the gate to operate the gate opener.

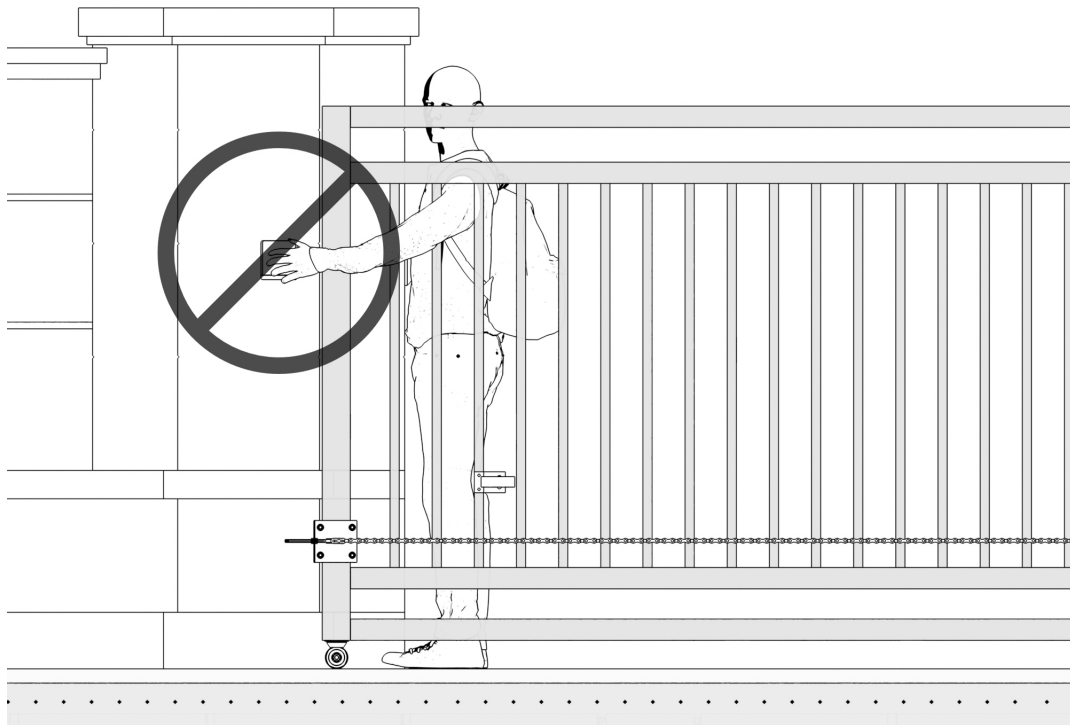

## 5.2 Base Component Assembly

Connect these base components as shown.

Parts to be used:

- M6×20 Hex Bolts (×4)
- M6 Spring Washers (×4)
- M6 Flat Washers (×4)
- M6 Hex Nuts (×4)

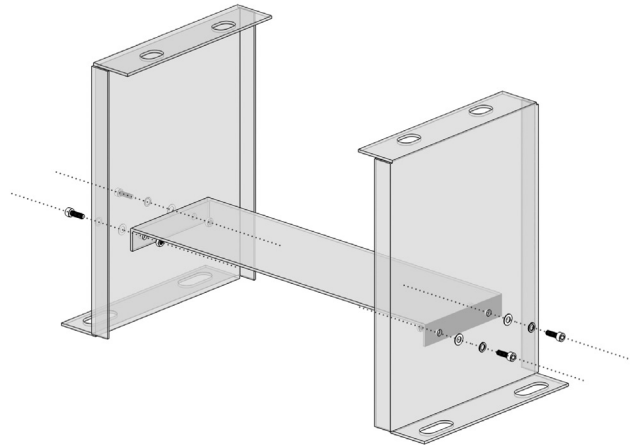

## 5.3 Base-Main Unit Connection

1. Remove the protective cover from the main unit and place it nearby. Attach this unit to its base using the following fasteners, being careful not to overtighten them.

Parts to be used:

- M10×45 Hex Bolts (×4)
- M10 Spring Washers (×4)
- M10 Flat Washers (×4)

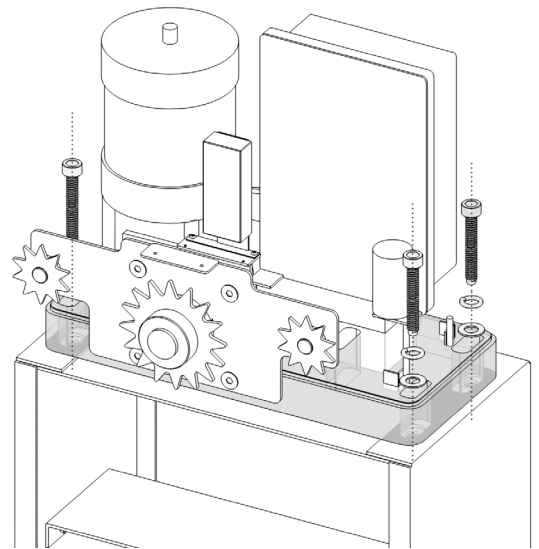

2. Select an appropriate position for the main unit and place it.

- Ensure the distance between the chain box and your gate is no larger than 10 inches (25 cm) while allowing enough space to prevent scratches and collisions during operation.
- Ensure a minimum distance of 7.9 inches (20 cm) between this unit and the nearest gate frame (with the gate fully closed)
- Ensure this unit is parallel to the gate.
- It is advisable not to permanently fix this unit for now, in case it needs to be relocated during the ongoing installation.

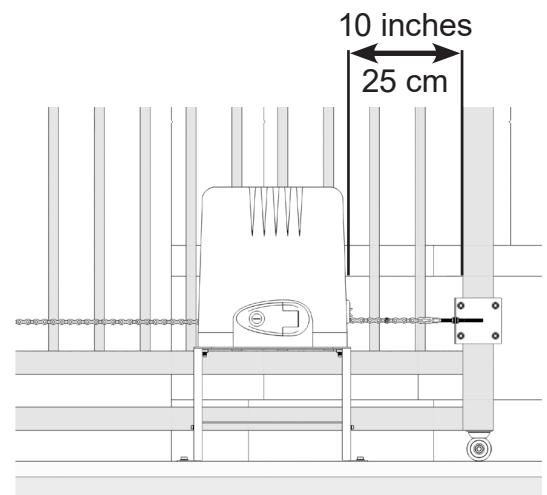

## 5.4 Chain Installation

Below is a diagram of chain installation.

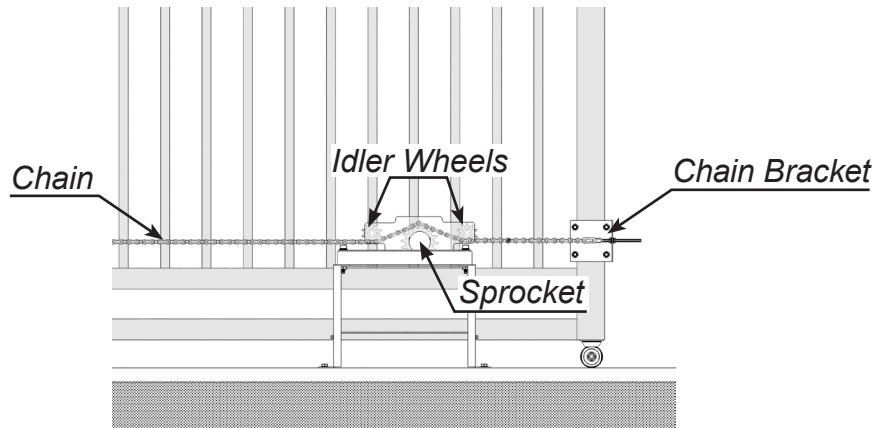

Schematic diagrams of chain bracket assemblies installed on square gate frame and round gate frame are shown below.

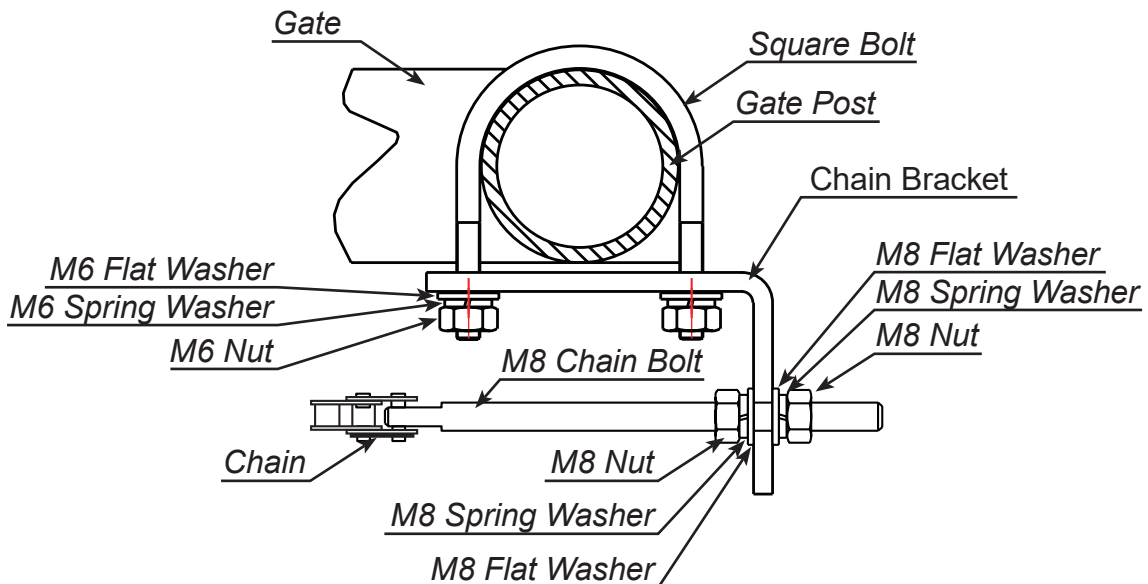
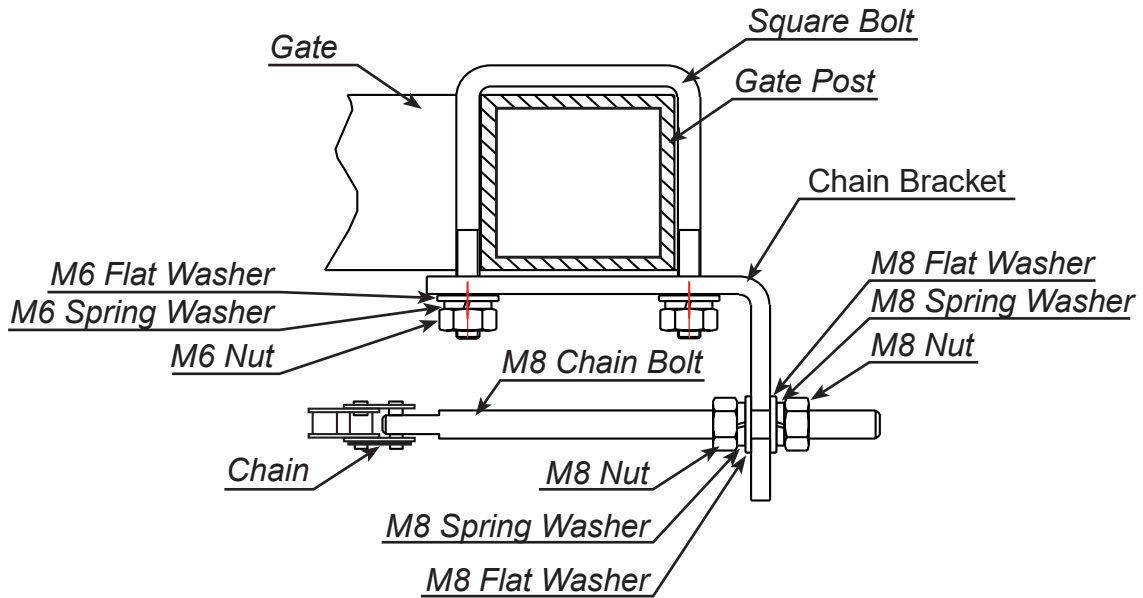

1. Determine the height of the marked idler wheel using a tape measure (not included). This value represents the mounting height of each chain bracket based upon its horizontal centerline. On your gate, mark the mounting height for both chain brackets.

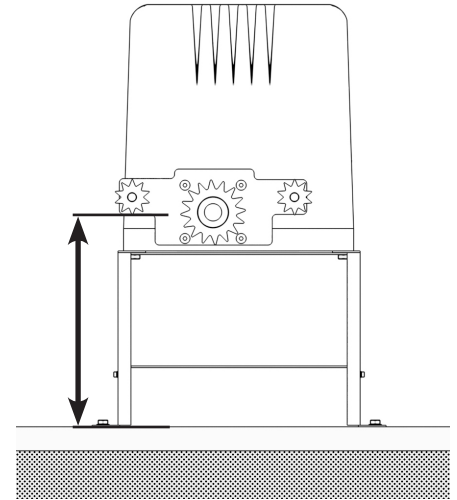

2. Depending on your gate frame style, use the provided arched or square U-bolts to secure the chain brackets to the previously marked locations.

If neither of the U-bolts suits your gate frame, opt for other appropriate fasteners.

- Chain Brackets (×2)
- Arched or Square U-bolts (×4)
- M6 Flat Washers (×18)
- M6 Spring Washers (×8)
- M6 Hex Nuts (×8)

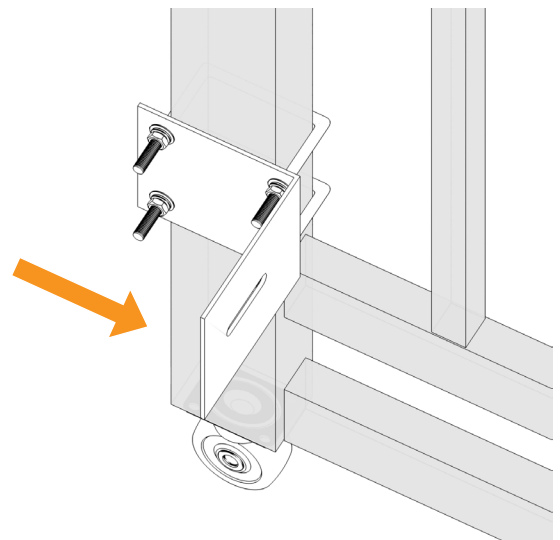

It is recommended that you position the brace for the chain bolt on the side of the gate frame nearer to the motor (as shown in the image above), but it can be used in an alternative position if necessary (as shown below).

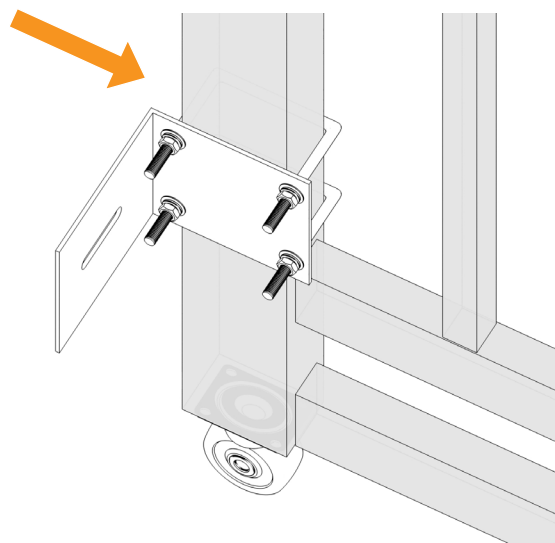

3. Attach the M8 bolts to the chain brackets as shown. Fine tune the pins on the brackets as needed.

- M8 Bolts (×2)
- M8 Hex Nuts (×4)
- M8 Spring Washers (×4)
- M8 Flat Washers (×4)

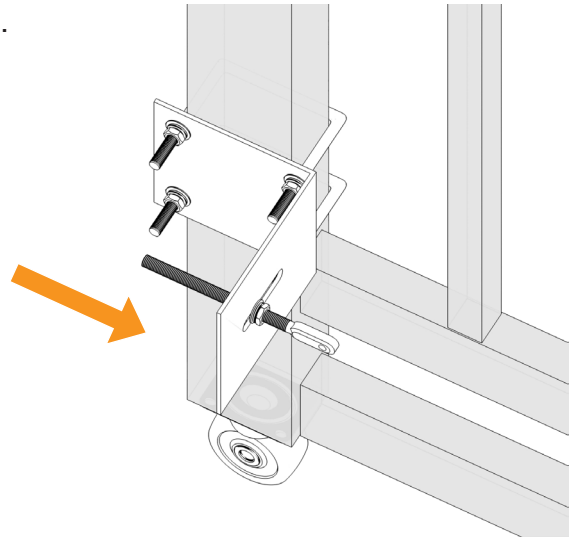

**Note**

Do not tighten these fasteners completely for now.

4. Measure the distance between the two chain brackets as shown to see the necessary length of the chain's extension. This package includes two chains, each 9.8 feet (3 m) long.

- If the distance is 9.8 feet (3 meters) or less, cut off the excess chain section while leaving a certain amount as needed.
- If the distance is 9.8–19.6 feet (3–6 meters), join the two chains and make your cut as above.
- If the distance is 19.6 feet (6 meters) or more, use a #41 galvanized chain (not included).

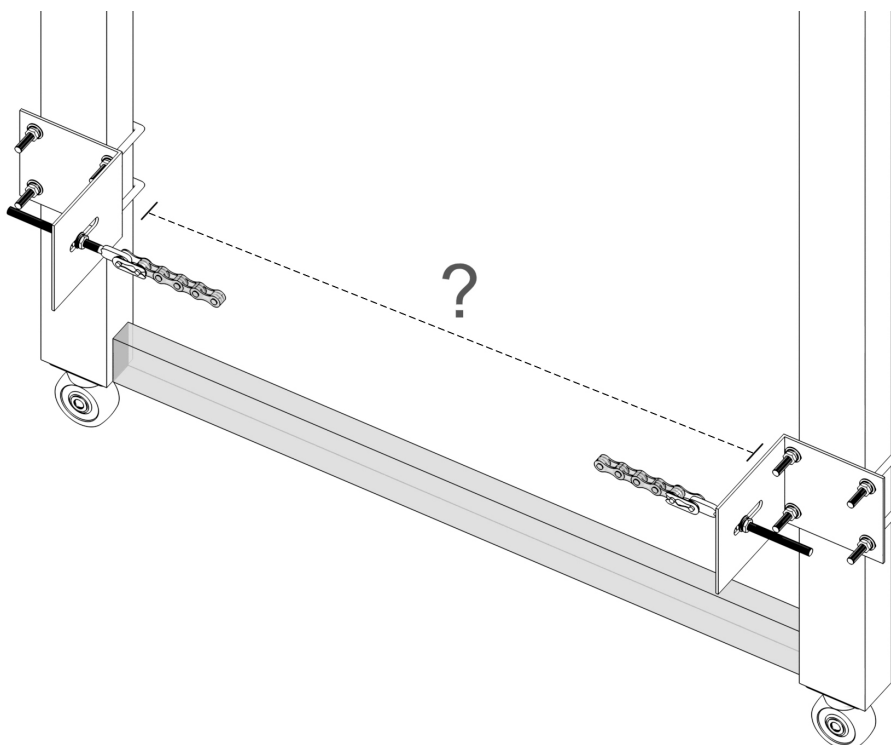

5. Install the chain adjacent to the main unit.

Connect both ends of the chain using either of the provided chain joints, pressing the clip into place with pliers (not included) as shown.

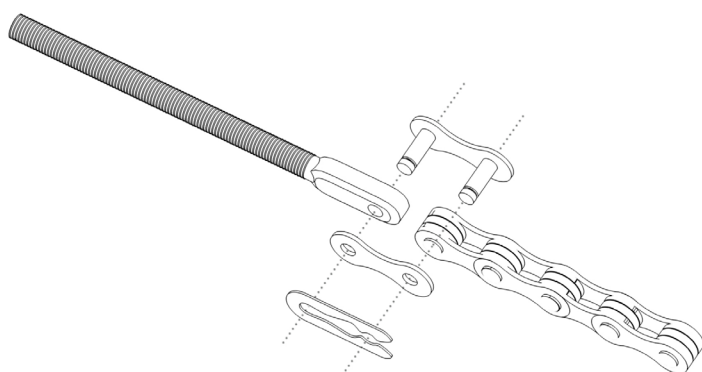

**Chain Bolt and Chain**

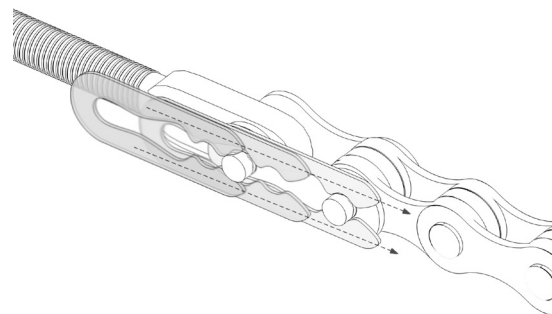

**Joint Fixation**

6. Unscrew the locking bolts from the chain box and then remove its protective cover. Run the chain through the chain sprocket and idler wheels. See illustration.

Check that the chain between the gate post and the idler wheel is level; if not, adjust the height of the chain bracket.

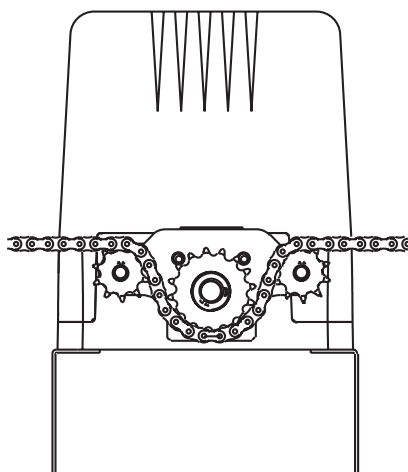

7. Pull the chain onto the other bracket. Repeat Steps 5–6 to complete the connection and installation. If necessary, fine tune the M8 bolts to achieve your desired positioning.

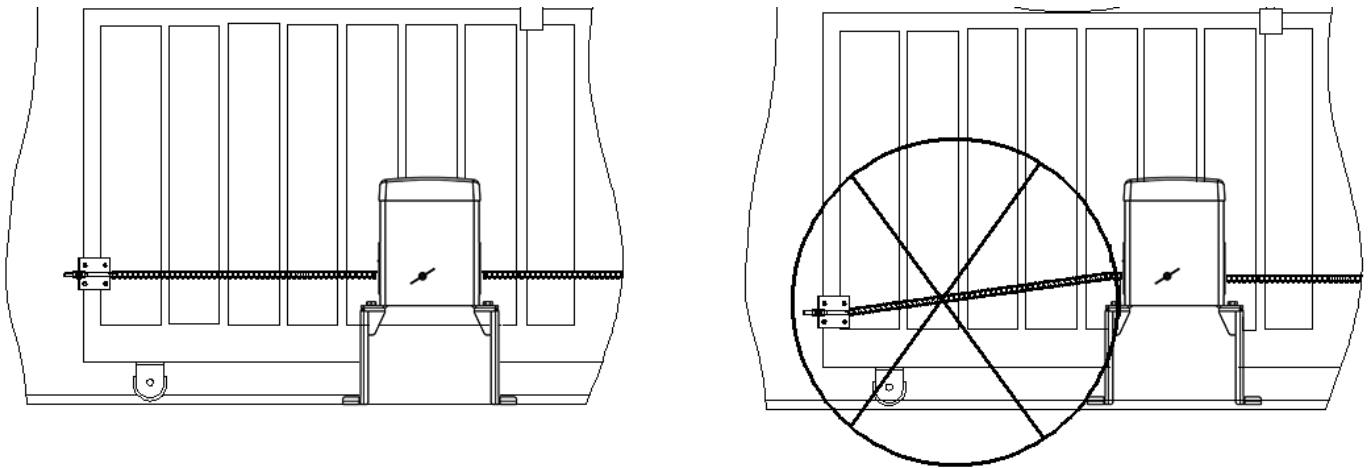

Front View

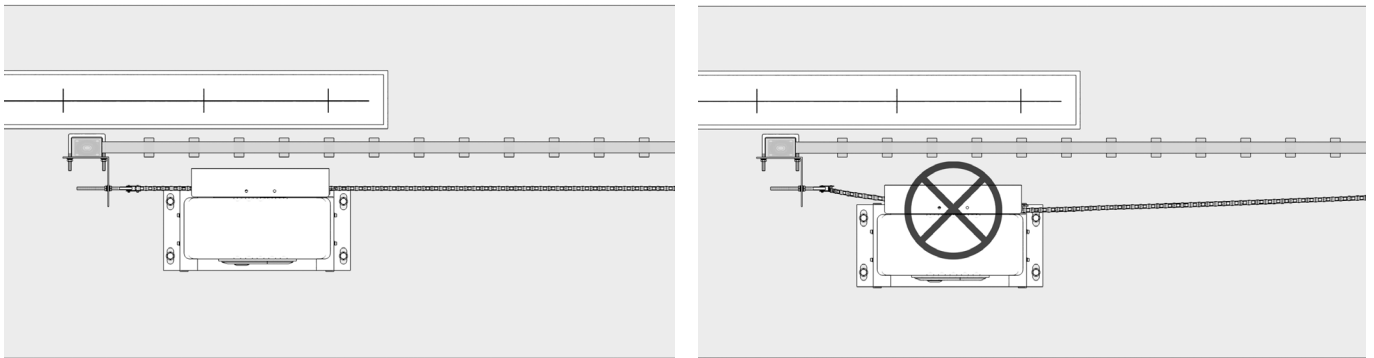

Top View

8. Adjust the nuts on each M8 bolt until your preferred tension is reached. Cut off any excess chain section if needed.

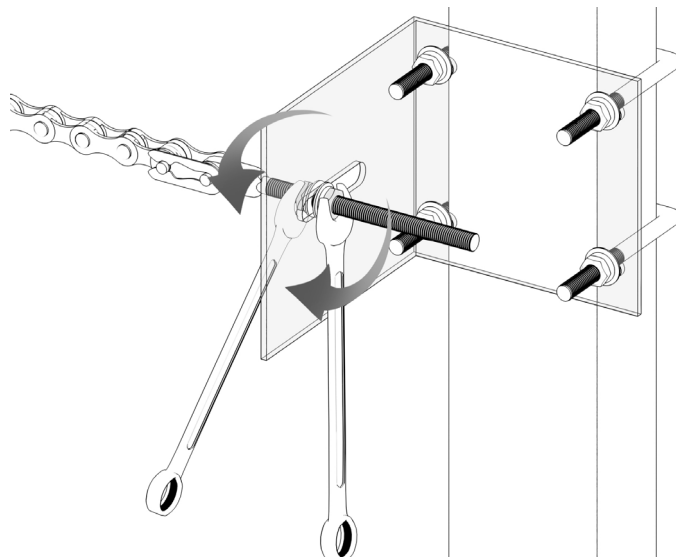

## 5.5 Chain Test

1. Unlock the motor to enable manual control mode.

**Note**

This device is equipped with manual control mode. Only activate this mode in case of power loss or for emergency.

Insert either manual key and turn it 90° clockwise. Then, pull the release lock to its maximum extent and the sprocket is separated from the shaft and is free to rotate.

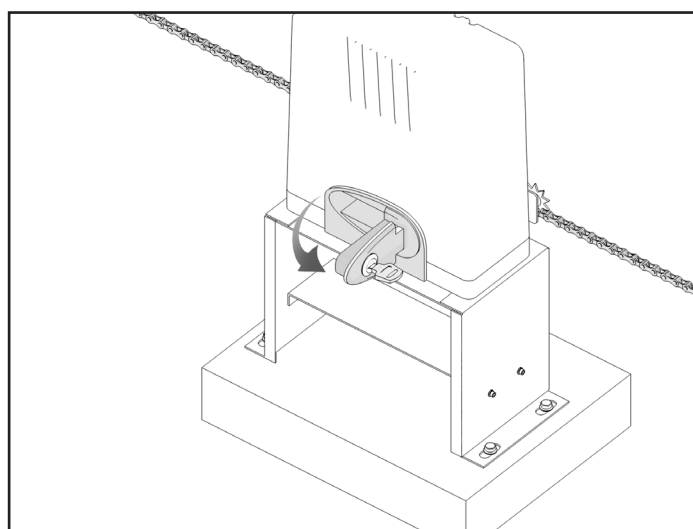

2. Manually slide your gate, checking that it moves smoothly. If necessary, reposition the main unit or chain or replace the chain with a suitable one as mentioned above.
3. Push the release lock back into place and deactivate manual mode.

## 5.6 Chain Box Cover Reinstallation

Making sure the chain is correctly installed and operates in a smooth way, reinstall the removed protective cover onto the chain box using its fasteners.

**Note**

Tighten all fasteners to lock the protective cover in place.

## 6. Electrical Component Installation



### Warning

Make sure **ALL** exposed wires are **TIGHTLY** twisted and **FULLY** inserted into the terminals **WITHOUT** loose strands.

This chapter introduces electrical connection operations required for installing the gate opener. Please follow the instructions for installation.

### 6.1 Important Information

- Wear appropriate PPE and obey the following instructions to prevent personal injury.
- Check that earthing is carried out correctly for all metal parts.

### 6.2 Circuit Connection Methods

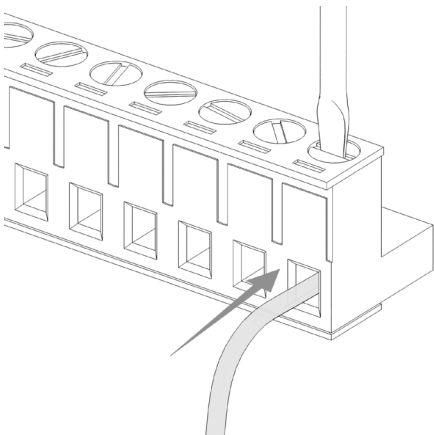

#### Connection to Terminals

Insert the exposed metal part of each cable into the right terminal and tighten the corresponding flathead bolt to secure this connection.

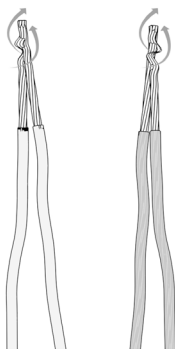

#### Extension



Use electrician's pliers (not included) to tightly twist the exposed metal parts of the two cables together and then wrap them with electrical tape around three times for optimal coverage. The tape's width should be greater than the lengths of the metal parts.

# 6.3 Control Board Description

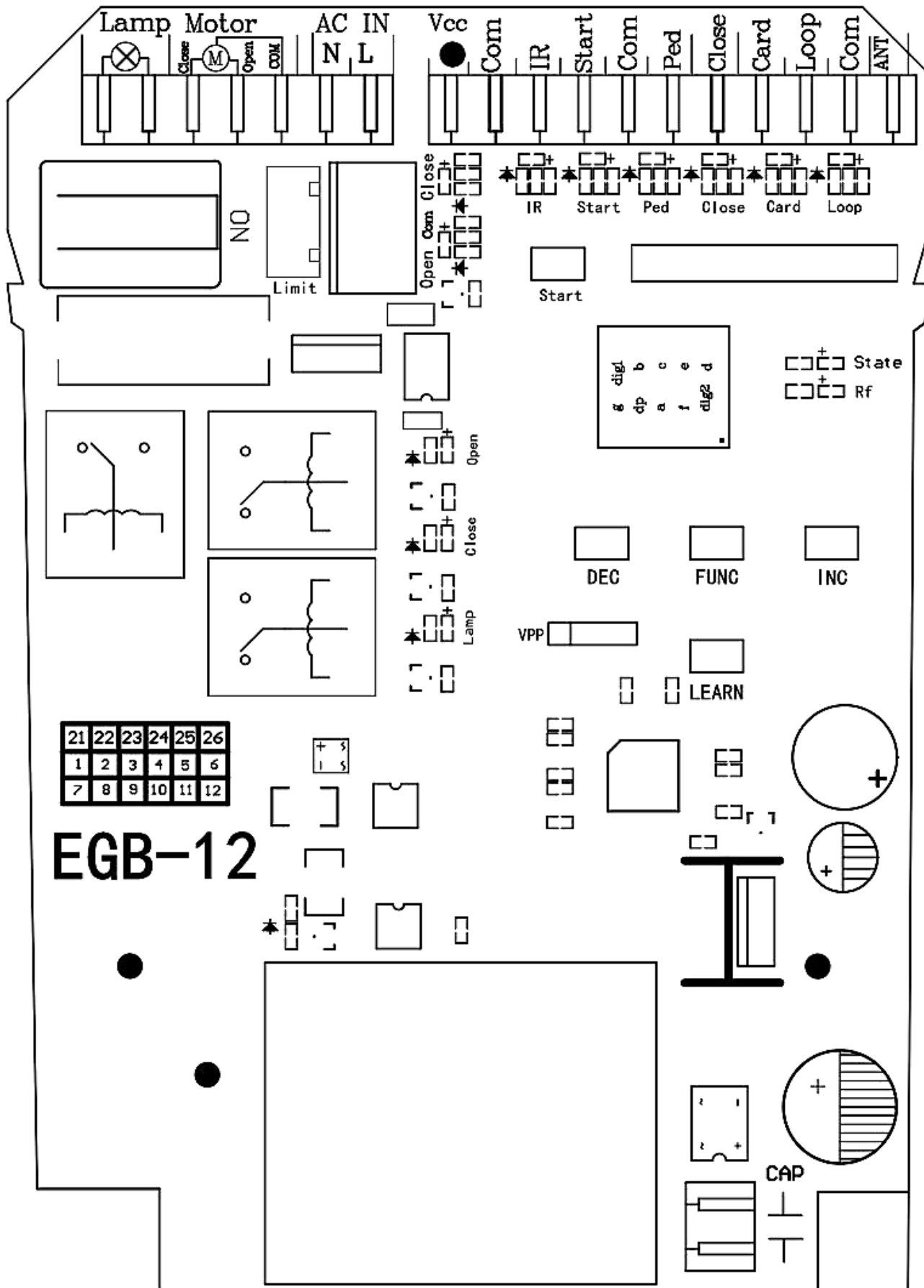

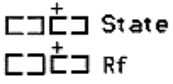

## Overview

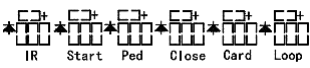
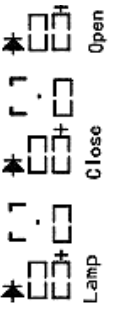

## Indicator Lights

Item	Name	Description
 <p>State Rf</p>	System Status ("State", red)	Turns on upon the system's initialization after power-on and remains on if the system is operating normally
		Flashes once every 1 second during the closing countdown
	Radio Frequency ("Rf", blue)	Provides instructions including code learning and clearing
		Flashes rapidly upon receiving a custom rolling code signal, whether it has been learned or not
 <p>Close Open</p>	Closing Limit Signal ("Close")	Turns on when the closing limit switch is triggered
	Opening Limit Signal ("Open")	Turns on when the opening limit switch is triggered
 <p>IR Start Ped Close Card Loop</p>	Signal Terminal	<ul style="list-style-type: none"> <li>"IR": Infrared sensing signal, which turns red when detecting an obstacle and remains off otherwise by default and vice versa if the PA value is set to "1" (For the PA setting, refer to Function <b>Configuration—Advanced Configuration—Parameter Adjustment.</b>)</li> <li>Upon receiving a signal, the corresponding indicator will light up.                             <ul style="list-style-type: none"> <li>"Start": Loop control signal</li> <li>"Ped": Pedestrian mode signal</li> <li>"Close": External device closing signal</li> <li>"Card": Card swiping signal</li> <li>"Loop": Loop detection (ground sensing) signal</li> </ul> </li> </ul>
 <p>Open Close Lamp</p>	Gate-Open Signal ("Open", blue)	Turns on when the gate is opening
	Gate-Close Signal ("Close", red)	Turns on when the gate is closing
	Warning Light ("Lamp")	Turns on when the warning light is activated

## Control Buttons

Item	Name	Description
	Starting Button (“Start”)	Activates the preset mode, causing your gate to open, stop, and close alternately
  	Decrease Button (“DEC”)	Decreases values
	Function Button (“FUNC”)	Opens setting menus, confirms changes, and saves data
	Increase Button (“INC”)	Increases values
	Learning Button (“LEARN”)	Programs or removing the remote control

## Digital Display

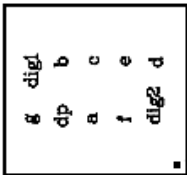
Item	Name	Description
	Digital Display	Displays values

## Interfaces

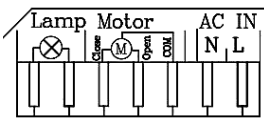
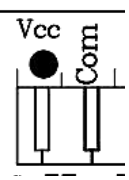
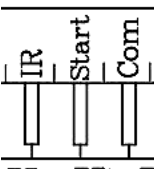
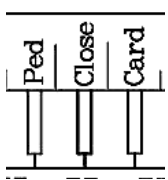
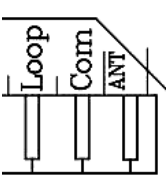
Interface	Name	Description
	Warning Light Ports ("Lamp")	Warning light power control (AC power output)
	Motor Communication Ports ("Motor")	"Com": Common terminal of AC motor power supply "Open" and "Close" determine the opening direction of the gate opener (either right to left, or left to right).
	AC & IN Power Supply Ports ("AC IN")	"N": AC power neutral line input "L": AC power live line input
	Voltage-at-the-Common-Collector Port ("Vcc")	Positive terminal of 12V DC power supply (actually 17–20V, max. 200 mA)
	Common Terminal 1 ("Com")	Grounding terminal as the trigger source for signal ports or negative terminal of the power supply above
	Infrared Sensing Port ("IR")	Infrared signal input port for connecting external infrared sensors
	Loop Control Port ("Start")	Loop control signal input port for connecting to external devices such as push buttons, wired keypads, receivers, etc.
	Common Terminal 2 ("Com")	Signal input port for connecting with COM or GND terminal.
	Pedestrian Mode Port ("Ped")	Pedestrian mode (gate opening) signal input port
	Gate-Close Port ("Close")	Gate closing signal input port for connecting with external devices that will close the gate
	Card Port ("Card")	Card swiping signal input port for connecting with external devices that will open the gate
	Loop Detection Port ("Loop")	Vehicle detection signal for connecting with a loop detector (ground sensor)
	Common Terminal 3 ("Com")	Signal input port for connecting with COM or GND terminal.
	Antenna Port ("ANT")	Remote control antenna port

## 6.4 System Powering

This device is compatible with 110V AC 60Hz power sources.

1. Use conduits to protect the electrical cables and then thread one end of the cables connected to the gate opener through the hole in the base.
2. Strip both ends of the cables to an appropriate length of inner double-core cores using wire strippers (not included).
3. Open the control board's protective cover, connect the neutral wire of the power line to the "N" terminal, and connect its live wire to the "L" terminal.

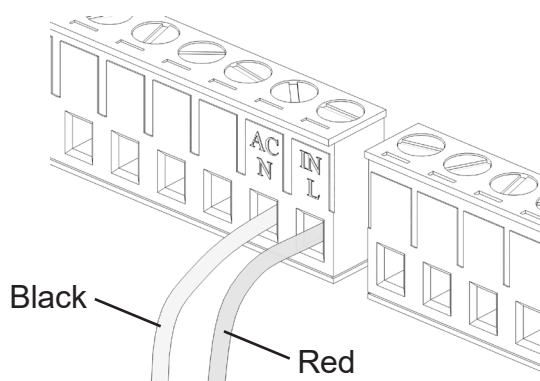
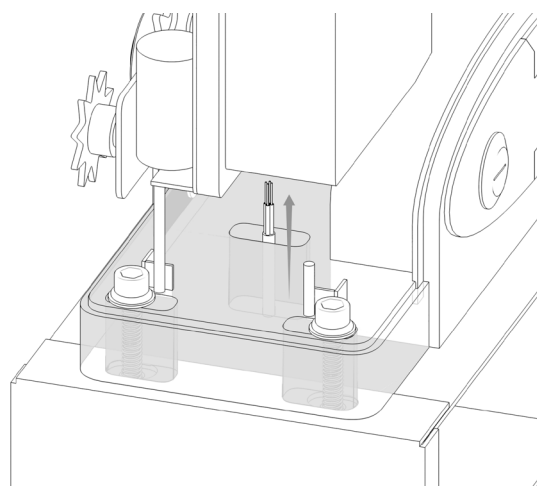

4. Connect the other end of the power line to the power plug. Choose a compliant product that matches your local power supply for the plug.

## 6.5 Direction Reversal

This device is designated for immediate use with gates that slide open to the right.

The motor cables are already preconnected as shown. Ports 3 and 4 determine the opening direction of the gate opener (either right to left, or left to right). Port 5 is designated for COM or GND connection.

If your gate slides open to the left, reconfigure the motor cables as follows.

1. Disconnect the motor cables from the main control board.
2. Swap the cables that were previously connected to Ports 3 and 4. Then establish new complete connections.

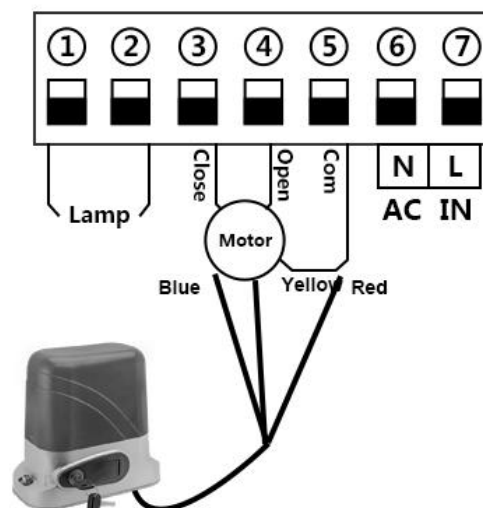

## 6.6 Limit Switch Magnets

This product employs magnetic limit switches to achieve distance limitation of a gate's movement during the process of opening or closing. After the gate reaches its intended position, its motor automatically stops.

This product includes two magnetic components, one in blue and the other one in red, which are corresponding to their identically colored indicator lights—blue for opening and red for closing. Install these magnets onto your gate. As the gate moves, these magnets will pass the opener and be detected by the sensor inside the opener immediately, causing the opener to stop operating so as to accomplish the limit effect.



### Note

The description above is applicable to gates that slide open to the right. For a left-slide-open gate,

- Swap the gate-close and gate-open cables. Refer to ***Electrical Component Installation—Direction Reversal*** for detailed instructions.
- Swap the limit switch magnets as needed for ease of debugging and operation.

To fit the structure of the internal sensor, install the red magnet at a higher position and the blue magnet at a lower position within its sensing range, ensuring the distance between the two magnets are not too small.

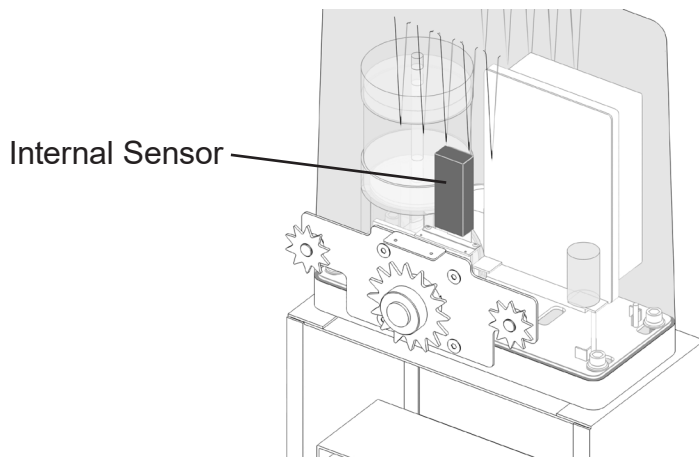

Follow these steps for your installation. For ease of debugging, remove the protective cover from the control board and connect this device to power.



### Caution

The magnetic limit components provide strong magnetism. When handling them, exercise caution to prevent pinching.

1. Install the gate-open and gate-close limit switch magnets separately on the magnet bracket. You can adjust their positions as needed during the subsequent processes.

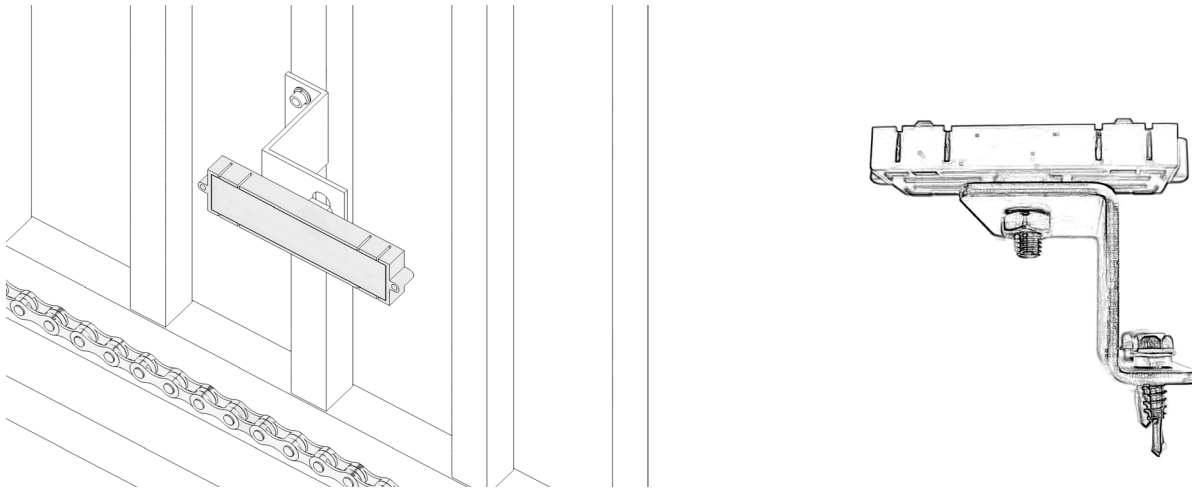

2. Install the gate-close limit switch magnet. Close the gate completely and determine the exact position for installation.

**Note:** To ensure safe use, the magnet bracket should ideally be installed at the center of the gate's rail and should **NOT** be positioned too close to the edge.

Place the magnet bracket assembly (with the long side of the limit switch magnet parallel to the ground) onto the intended installation position. If the "Close" limit indicator light on the control board comes on, mark the installation hole positions using a pen or other proper instruments. If it does not come on, adjust the installation position.

3. Drill holes and secure the magnet bracket to the gate pillar using its fasteners.
4. Install the gate-open limit switch magnet. Open your gate to its maximum position and place the magnet at an appropriate location as described in Step 1. Ensure the magnet is not positioned too close to the edge of the gate's rail and adjust the maximum open position if necessary.
5. When finished, use the gate opener to perform an open-and-close test to ensure the correct installation of the limit switch magnets.

### Right-Slide Opening

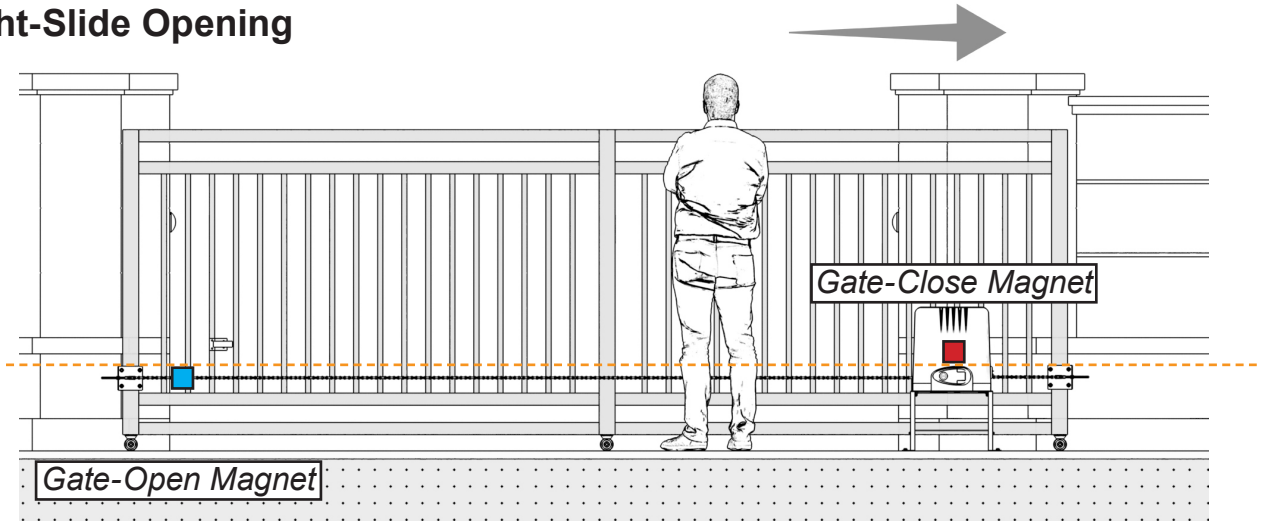

### Left-Slide Opening

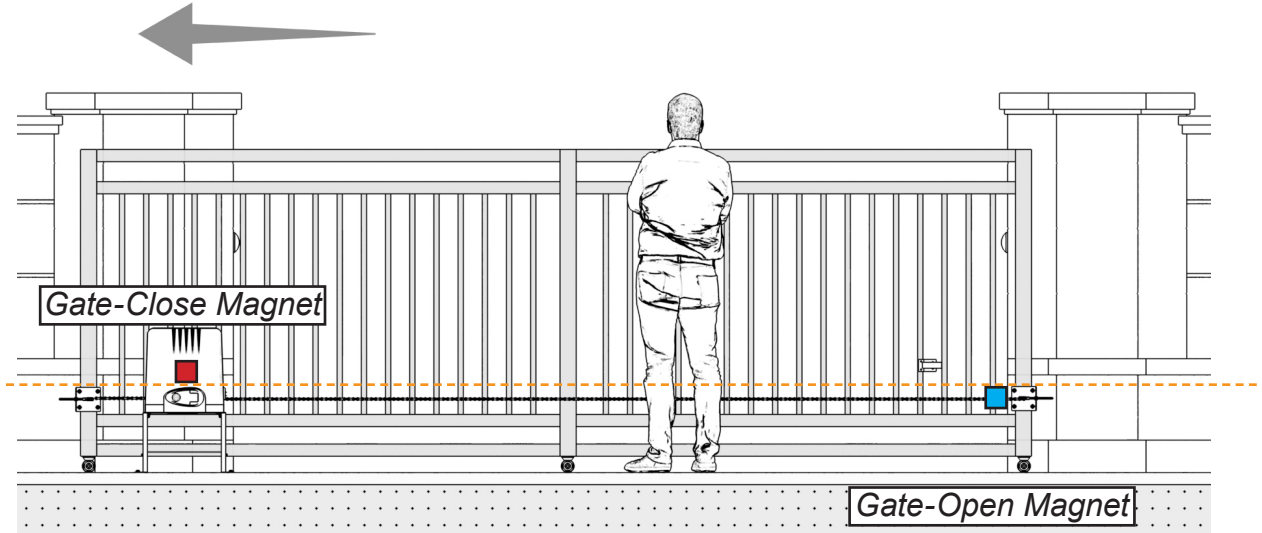

## 6.7 Fixation

Mark the locations of the mounting holes and then place everything in a safe place nearby.



**Warning**

The motor must be firmly secured for safe use. Do not attempt to use it when the base is loose or only secured to thin pavement.

If the area is covered by concrete that is no less than 10 inches (25 cm) thick, drill four matching holes and fasten the base to the ground using the provided anchor bolts.

#### Necessary Tool and Fastener:

- Power Drill
- M10×80 Anchor Bolts

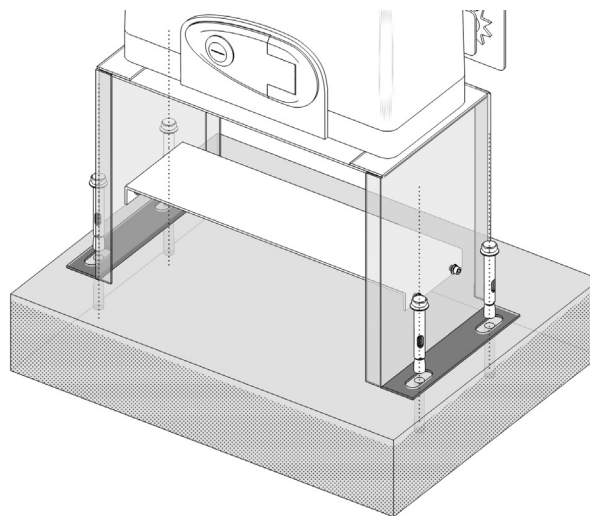

If the area has no suitable concrete, to ensure a sturdy and reliable connection between the gate opener and the ground, it is recommended to pour a rectangular concrete footing first. Then, following the methods mentioned earlier, install the gate opener components onto the concrete footing. The steps for pouring are as follows.

1. Based on the hole positions marked in the previous step, plan the location on the surface of the concrete footing on the ground. Checking that the concrete footing does not interfere with the gate's normal operation, try to position it closer to the gate to ensure the gate opener can be installed in an appropriate location.
2. Dig a hole that is 20 inches (50 cm) wide, 14 inches (35 cm) long, and 8 inches (20 cm) deep.
3. Prepare a mold box of the same dimensions and place it into the hole. You can use a non-stick spray to minimize moisture absorption and facilitate future removal.
4. Fill the mold box with concrete, ensuring a smooth and even top surface. You will need at least 1.25 cubic feet (35 L) of concrete (equivalent to about the volume of three standard 60-pound bags or slightly more than the volume of two standard 80-pound bags). For further reinforcement of the concrete footing, you can place a metal wire frame near its sides.
5. Wait for at least 24 hours and protect the area from the elements to allow the concrete to set properly.
6. Remove the mold box from around the concrete and compact the soil firmly back into place. Adjust the footing as needed to ensure it fits snugly, remains securely positioned, and has a completely level top surface.



#### Warning

If you notice that the concrete footing shakes with the gate opener during use, add extra concrete or further secure the base as needed.

## 6.8 Infrared Equipment Connection (SGO-1801-GY Only)

1. Connect Ports 12 and 10 to the “COM” and “OUT” ports of the receiver respectively.

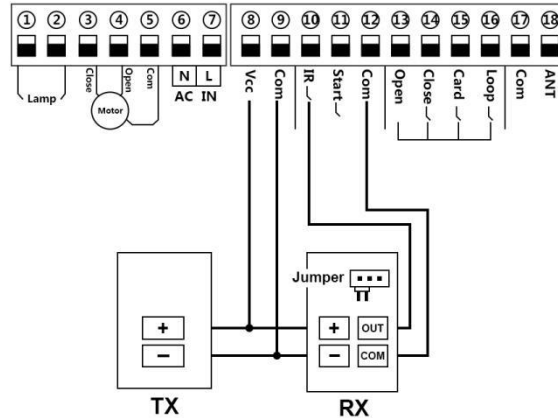

T means Transmitter and R means Receiver

2. Prepare two more two-core wires. First, connect one end of either to the positive (“+”) and negative (“-”) terminals of the receiver. Then, connect the other in a similar manner to the positive and negative terminals of the transmitter.
3. Prepare the other ends of the wires, align the positive to positive and negative to negative, and twist them together.

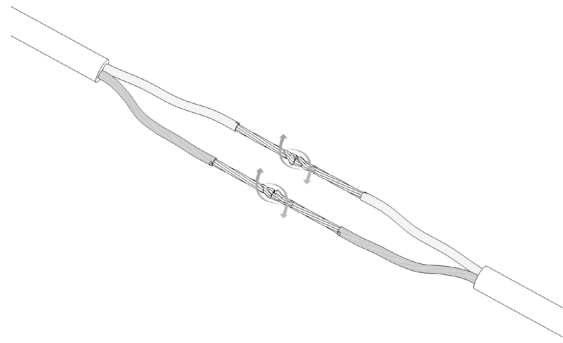

4. Connect the positive wires of both the transmitter and receiver to Port 8. Connect their negative wires to Port 9.
5. Secure the transmitter and receiver to the gate pillar using their fasteners.
  - The installation height should be at least 65.6 feet (20 meters).
  - Pay attention to the labeling on the transmitter and receiver during installation. Do not place them upside down.
  - Ensure both the transmitter and the receiver are vertically installed.
  - Ensure the transmitter and receiver are aligned along the same horizontal line.
6. Secure the casing of the transmitter and receiver using their locking bolts.

If you have purchased SGO-0000-01 and SGO-EC06-02, you can optionally install an infrared sensing device as needed. The wiring methods provided above are for your reference, but for specific installation instructions and precautions, follow the manual provided with the infrared equipment you have purchased.

## 6.9 Wire Connection Guidance of Optional Accessories

### Warning Light

You can choose to connect a warning light to Ports 1 and 2. When the gate is in motion, the light will flash. When the gate stops, the light will turn off.

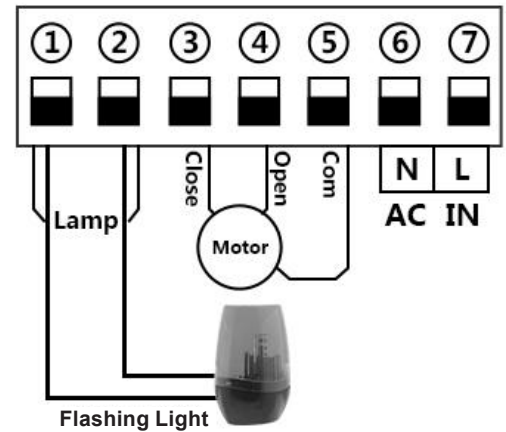

### Push Button

You can also use an additional manual switch (push button) to issue gate opening commands. Connect its power inlets to Ports 8 and 9 and its control signal interfaces to Ports 11 and 12 as shown.

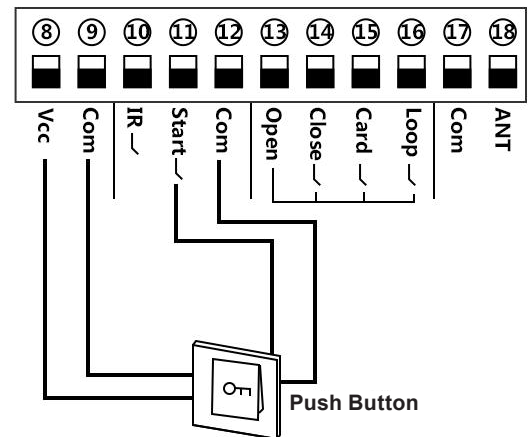

### Swipe Card, Digital Keypad, and Other External Devices

You can choose to install external devices, allowing personnel access to your property using an identification code or card that you provide.

Terminal 15 is designated for gate opening only.

Terminals 12 and 15 are designated for connecting external access control devices (such as swipe cards and wired digital keypads) and for opening gates only.

Terminals 8 and 9 are for supplying power to swipe cards.

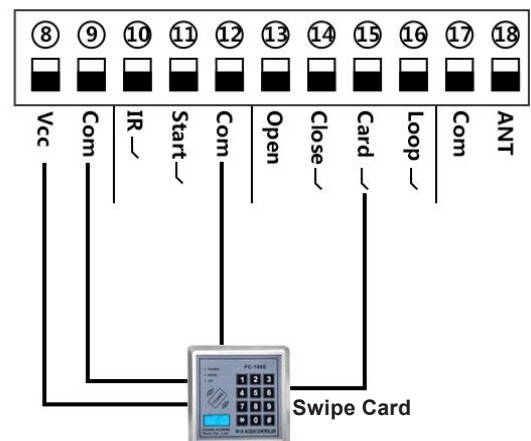

## Loop Detector

You can install a loop detector (i.e., vehicle detector or ground sensor) to enhance the convenience of using the gate opener.

If the gate opener receives a signal from the loop detector when your gate is opening or at its fully open position, it will hold the gate where it is. 2 seconds after no signal is received, the gate will close.

If the gate opener receives a signal from the loop detector while your gate is closing, it will move the gate back to its maximum opening position. 2 seconds after no signal is received, the gate will close.

The loop detector and its accompanying devices need to be purchased separately. Installation should comply with its user manual.

### Circuit Connection for Loop Detectors

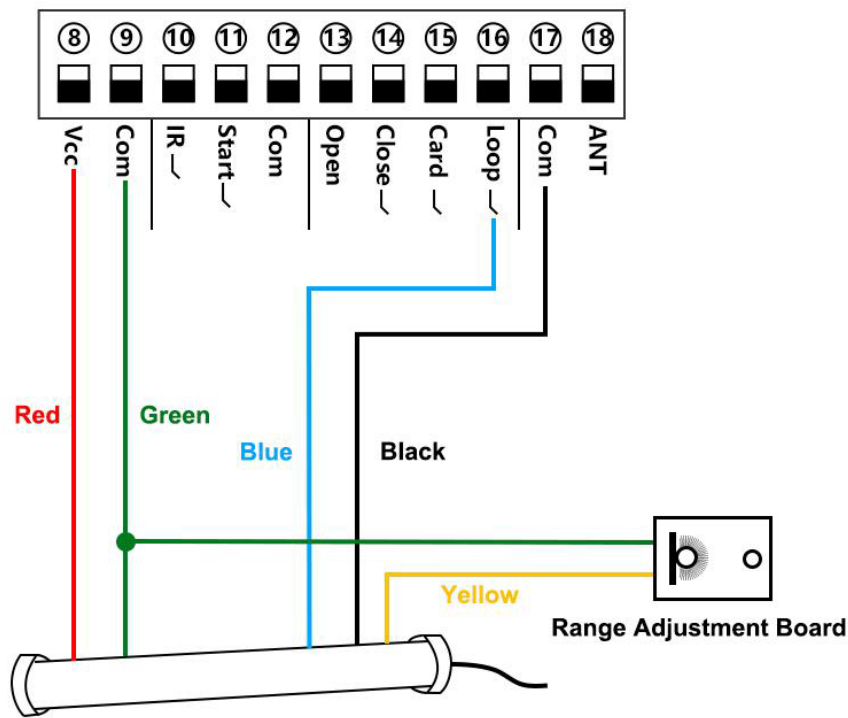

Color	Usage	Connection
Red	Input Voltage (+)	Terminal 8
Black	Relay's Common	Terminal 17
Green	Ground/Common (-)	Terminal 9 and Range Adjustment Board
Blue	Relay's Normally Open	Terminal 16
Yellow	Range Adjustment Potentiometer (POT)	Range Adjustment Potentiometer (POT)

## 7. Operation

### 7.1 Remote Control Description

The system can support 120 remotes at most. Each of the provided remote control is as below.

The remote control applies three-button control mode by default and can be toggled to single-button control mode. Refer to **Function Configuration—Advanced Configuration—Parameter Adjustment** for setting P7 to toggle this. When finished, the codes need to be relearned.

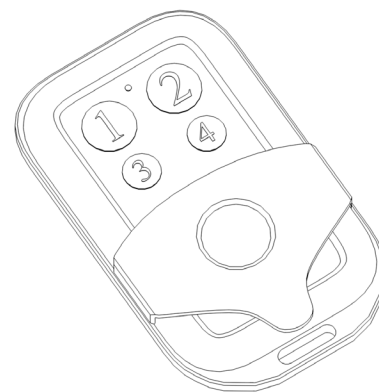

Three-Button Control Mode	Single-Button Mode
<b>Button 1:</b> Opens the gate	<b>Button 1:</b> Opens or closes the gate
<b>Button 2:</b> Closes the gate	<b>Button 2:</b> Activates or deactivates pedestrian mode
<b>Button 3:</b> Stops the gate movement	<b>Button 3:</b> Opens or closes the gate
<b>Button 4:</b> Activates or deactivates pedestrian mode	<b>Button 4:</b> Activates or deactivates pedestrian mode  In this mode, you can program Buttons 1 and 2 to operate one gate opener and Buttons 3 and 4 for another gate opener.

**Note:** Pressing Button 1 or 3 opens and closes your gate alternately. For instance, if the gate is open, your first press will close it and second press will reopen it.

### 7.2 Functions

Main functions of the system are as follows.

#### **Movement Limitation**

The motor stops running when the gate reaches its opening or closing limits.

#### **Mechanical Obstruction Feedback**

This function only operates during high-speed movement and will not be triggered if it is slow.

If an obstruction is encountered during the opening process, the gate opener stops the gate. If an obstruction is encountered during the closing process, the gate opener reverses the gate's movement, providing anti-pinch protection.

The gate opener's obstruction sensitivity is adjustable. A smaller value makes your gate more sensitive to obstructions while a larger value reduces the degree. Refer to Function Configuration—Advanced Configuration—Parameter Adjustment for details. The larger you set the value, the stronger the gate's force against obstruction and the less sensitive the gate opener to activate its anti-pinch protection during high-speed movement.

## **Infrared Obstruction Feedback**

The transmitter emits infrared light. If an obstacle is encountered, some of the infrared light will be reflected to the receiver. While your gate is closing, if the receiver detects an infrared signal, the gate will reverse and reopen until it is in the designated position. 2 seconds after the infrared signal disappears, the gate will automatically close.

## **Automatic Closing**

Automatic closing functions only after your gate's opening limit has been triggered. Once the auto-close countdown begins, the "State" indicator light will flash once per second. The gate will close after the countdown ends and the infrared signal has disappeared for 2 seconds.

You can adjust the auto-close countdown time through the menu settings.

## **Pedestrian Mode**

When the remote control activates pedestrian mode using Button 2 or 4, your gate will automatically open. If you have enabled the auto-close function in pedestrian mode, the gate will enter an auto-close countdown after reaching the opening limit and will automatically close when the countdown ends.

The auto-open and close countdown times for the gate can be adjusted through the menu settings.

**Note:** Pedestrian mode only operates when the gate is at the closing limit position. The set opening time in pedestrian mode cannot exceed the gate's opening travel time.

## **Vehicle Detection**

If the gate is at the opening limit position or is in the process of opening and the loop detector (ground sensor) detects a vehicle passing by, the gate opener will perform an automatic closing action 2 seconds after no signal is received. If the gate is in the process of closing and a vehicle is detected, the gate opener will immediately reverse the gate's movement. 2 seconds after no signal is received, the gate opener will perform an automatic closing action.

**Note:** You can disable the auto-close function of the loop detector through the menu settings.

## **Travel Learning**

After the low-speed operation time is set, the travel learning function allows the system to allocate periods of low-speed and high-speed operation during one complete cycle of gate opening and closing.

**Low-Speed Operation Time:** As approaching the limit position, the gate transitions to slow-speed operation during a specified period of time, i.e., the low-speed operation time. The default setting is 2 seconds, which means the gate will start decelerating and enter low-speed operation for 2 seconds before reaching the limit position.

## Motor Running Protection

The motor will automatically stop running after continuous operation for 90 seconds.

## Manual Mode

This mode allows manual operation to replace intelligent control in case of power failure or other unexpected situations. Use the emergency release key for activation or deactivation.



**Warning**

**ONLY** use the emergency release key when the gate is not moving or the device is disconnected from power.

## 7.3 Code Display

No.	Code	Description
1	OP	Gate opening
2	CL	Gate closing
3	--	Gate stopping
4	LO	Gate at its full opening limit
5	LC	Gate at its full closing limit
6	PD	Pedestrian mode activated
7	OU	Motor running protection triggered
8	PH	Photocell activated
9	LP	Loop detector (ground sensor) activated

Use the control board's buttons and the remote control to adjust function settings. After the system is powered on, a beep will sound and the digital display will show the model and software version. The "State" indicator light should remain on, indicating the normal functioning of the system.

## 7.4 Basic Function Configuration

### Accessing the Setting Menus

Hold **FUNC** until "P0" is displayed, opening the setting menus.

### Selecting Menus and Adjusting Values

Use **INC+** or **DEC-** to select a menu and increase or decrease a value.

### Confirming Selections and Saving Changes

After adjusting a value, press **FUNC** to confirm and save your change. Then a beep should sound to indicate success.

### Exiting the Setting Menus

When finished, press **LEARN** to exit the menus and turn off the display.

## 7.5 Advanced Function Configuration

### Learning Codes (Remote Control Learning)

The remote control must be successfully learned before use. Press **RF** and its indicator light should turn on. Press your preferred button on the remote control, and a short buzz will sound, indicating successful code learning. The digital display will show the number of the learned remotes.

#### **Note:**

- A maximum of 120 remotes can be learned. Since the digital display can only show two digits, numbers between 100 and 109 will display as "A" for the first two digits (e.g., "A8" for 108) and numbers between 110 and 120 will display as "b" for the first two digits (e.g., "b8" for 118).
- If "--" is displayed and 5 short buzzes sound, the storage space is full and no further learning can be done.
- If the controller does not receive a signal from the remote control within 8 seconds after **LEARNING** is pressed, the indicator light will turn off and the system will deactivate the learning mode.

### Clearing Codes

Clearing codes refers to removing the original remote control pairing code. Hold **RF** until a long buzz sounds, lasting for approximately 5 seconds. After successful clearing, "00" should be displayed.

**Note:** Clearing codes will render all previously paired remote controls inactive. After each clearing, relearning is required.

## Travel Learning

While the system is at its closing limit position, hold **INC** and **DEC** simultaneously until a long buzz sounds. The system should automatically cause the gate to open and close once and then a long buzz should go off again, with low-speed and high-speed times being allocated and shown on the digital display.

### Note:

- If the system is not in its closing limit position before starting learning, two short buzzes will sound, indicating that learning cannot be initiated.
- During travel learning, the remote control, obstruction feedback, loop detector (ground sensor), external digital keypads, etc. cannot function.
- If a single travel lasts for less than 5 seconds, 2 buzzes will go off, indicating the learning has failed.
- Alternatively, you can activate travel learning through the setting menu. For details, refer to the digital display settings explanation below.

Parameter Adjustment					
Parameter	Function	Custom Value	Default Value	Description	Remark
P0	Limit signal mode	0 & 1	1	0: Normally On 1: Normally Off	No user configuration required
P1	High-speed obstruction sensitivity	0–20	12	The smaller the value, the higher the obstruction sensitivity The larger the value, the lower the sensitivity	
P2	Low-speed operating time (sec.)	0–5 sec.	2	0: No low-speed operation time but full-time high-speed	
P3	Auto-close time for swipe cards (sec.)	0–99	10	0: Off 1: Minimum value required	
P4	Auto-close time in pedestrian mode (sec.)	0–99	10	0: Off 1: Minimum value required	

Parameter Adjustment					
Parameter	Function	Custom Value	Default Value	Description	Remark
P5	Auto-close time in standard mode (sec.)	0–99	0	0: Off 1: Minimum value required	
P6	Auto-open time in pedestrian mode (sec.)	0–20	5	0: Off 1: Minimum value required	
P7	Remote control modes	0 & 1	0	0: Three-Button Control 1: Single-Button Control	
P8	Warning light output	0 & 1	1	0: Off 30 seconds after the gate is fully closed and otherwise on 1: On while the gate is in motion and off when it is closed	
P9	Loop detector (ground sensor) activation	0 & 1	1	0: Disables the auto-close function 1: Enables the auto-close function, causing the gate to start closing 2 seconds after the loop detector trigger signal disappears	No impact on gate opening
PA	Infrared input	0 & 1	0	0: Infrared outputs normally open (NO) signal when there is no obstacle 1: Infrared outputs normally closed (NC) signal when there is no obstacle	
P-	Travel learning	0–10	0	Select “5” and confirm, a long buzz will sound. Note: Only “5” is selectable. Any other number will be invalid.	
Po	Reset	0–10	0	Select “5” and confirm, a long buzz will sound. Note: Only “5” is selectable. Any other number will be invalid.	

## 8. Troubleshooting

If any component of the system is known or suspected to malfunction or be improperly adjusted, **DO NOT** use before professional servicing is completed. Using with malfunctioning or improperly adjusted components may pose safety risks.

The following table outlines common problems and their respective standard solutions. Consult this table to address any encountered problems as needed. For substantial modifications to the device, seek professional assistance from trained technicians.

If this table cannot resolve your problem, discontinue use of this device and unplug it. Seek professional servicing. Be sure to have the correct model number and prepare a detailed problem description in advance to receive prompt and effective assistance.



**Warning**

- **ONLY** allow professional servicing by trained technicians.
- **ONLY** replace components with new identical ones.
- **ALWAYS** disconnect the device from power before performing any inspection or servicing.
- To check voltage and continuity, use a multimeter. Exercise caution when inspecting high-voltage terminals.
- When finished with any inspection or servicing, reinstall all removed protective covers into place.

No.	Problems	Possible Causes	Usual Solutions
1	The gate can only slide open in one direction.	Limit switch failure	Reposition the two magnets and try again. If this fails, hold the magnets against the limit switches and test using a multimeter. If it beeps, the limit switches are functioning correctly. If it does not, have the limit switches replaced with new identical ones.
		Incorrect circuit connections for the infrared sensor, etc.	Inspect the corresponding wiring.
		Damage to any electrical component on the control board	Have the problematic component replaced with a new identical one. If necessary, have the control board replaced.

No.	Problems	Possible Causes	Usual Solutions
2	The gate cannot open or close.	Power failure	Check that the power supply is working properly. Seek professional assistance if necessary.
		Limit switch failure	Reposition the two magnets and try again. If this fails, hold the magnets against the limit switches and test using a multimeter. If it beeps, the limit switches are functioning correctly. If it does not, have the limit switches replaced with new identical ones.
		Loose circuit connections	Fully reconnect and retighten the connections.
		Motor damage	Seek professional servicing. Have the motor replaced with a new identical one if necessary.
		Extended motor operation leading to excessive temperature, triggering overheating protection	Allow the motor to cool for at least 20 minutes before continuing use.
		Damage to any electrical component on the control board	Have the problematic component replaced with a new identical one. If necessary, have the control board replaced.
3	The remote control does not work.	Out-of-range positioning	Place the remote nearer to the gate opener and try again.
		Remote-receiver incompatibility	Reprogram the remote.
		Receiver damage	Have the receiver replaced with a new identical one.
		Battery outage	Replace the battery (12V23A) with a new identical one and check that the indicator light on the remote can turn on. If this fails, seek professional assistance.
4	When the programmed Button 1 or 2 is pressed for opening or closing, the gate stops midway or returns to its original position.	Insufficient resistance	Increase the high-speed obstruction sensitivity by adjusting the P1 setting using the display panel.
		Obstacle interference	Remove the obstacles

No.	Problems	Possible Causes	Usual Solutions
5	The gate stops moving before fully opening and does not return to its original position	Incorrect installation of limit switch magnets	Correct their positions and try again.
		Direction mismatch for a left-slide-open gate	Adjust the cable connection according to <b>Direction Reversal</b> .
		Magnetic sensor misfire	Enlarge the distance between the two limit switch magnets.
6	The gate opens normally but cannot close.	Obstructed infrared sensor (if any)	Remove the obstacle.
		Limit switch failure	Reposition the two magnets and try again. If this fails, hold the magnets against the limit switches and test using a multimeter. If it beeps, the limit switches are functioning correctly. If it does not, have the limit switches replaced with new identical ones.
		Starting capacitor fault in the motor	Have this capacitor replaced with a new identical one.
		Damage to any electrical component on the control board	Have the problematic component replaced with a new identical one. If necessary, have the control board replaced.
7	The motor is operating properly while the gate is not moving.	Non-engagement of the manual release lock	Re-engage the manual release lock using the provided keys.

## 9. Maintenance

- **Keep the gate opener clean.**

Disconnect this device from power and remove dirt or dust from its external surface using a soft cloth wetted with water or a mild cleaning solution. Do not use harsh abrasive or caustic chemicals and do not allow any electrical components to become wet. Also use a soft brush or OSHA-compliant compressed air to clean out any vents and openings.

- **Perform monthly testing, ensuring proper reaction to obstacles.**

The gate **MUST** reverse upon contact with a solid object or halt when an object triggers the non-contact sensors. After adjusting the force or travel limit, perform a retest. Failure to properly retest following adjustments can heighten the risks of personal injury or even death.

- **Inspect the items listed in the following form every six months.**

This form is designated to facilitate your maintenance tasks. If encountering any issues, contact the manufacturer or an authorized local contractor for assistance.

### Maintenance Record Form

Item		Record		Record		Record	
		Result	Date	Result	Date	Result	Date
1	Lubrication for moving parts						
2	Loose anchor bolts						
3	Loose or corroded wiring						
4	Proper earthing and termination						
5	Obstacle stop/reversal function						

Item		Record		Record		Record	
		Result	Date	Result	Date	Result	Date
1	Lubrication for moving parts						
2	Loose anchor bolts						
3	Loose or corroded wiring						
4	Proper earthing and termination						
5	Obstacle stop/reversal function						

Item		Record		Record		Record	
		Result	Date	Result	Date	Result	Date
1	Lubrication for moving parts						
2	Loose anchor bolts						
3	Loose or corroded wiring						
4	Proper earthing and termination						
5	Obstacle stop/reversal function						

Item		Record		Record		Record	
		Result	Date	Result	Date	Result	Date
1	Lubrication for moving parts						
2	Loose anchor bolts						
3	Loose or corroded wiring						
4	Proper earthing and termination						
5	Obstacle stop/reversal function						

## 10. Disposal

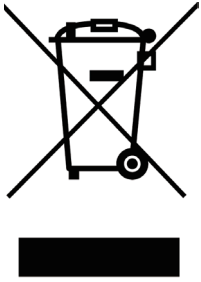

Electrical products should not be disposed of with household products. In the EU and UK, according to the European Directive 2012/19/EU for the disposal of electrical and electronic equipment and its implementation in national laws, used electrical products must be collected separately and disposed of at the collection points provided for this purpose. Locations in Australia, Canada, and the United States may have similar regulations. Contact your local authorities or dealer for disposal and recycling advice.

## 11. Contact Us

Thank you for choosing our products! If you have any questions or comments, contact us at [contact@cssupportgroup.com](mailto:contact@cssupportgroup.com) and we'll resolve your issue ASAP!

For a .pdf copy of the latest version of these instructions, use the appropriate app on your smartphone to scan the QR code to the right.

