

# Smart Lever User Manual

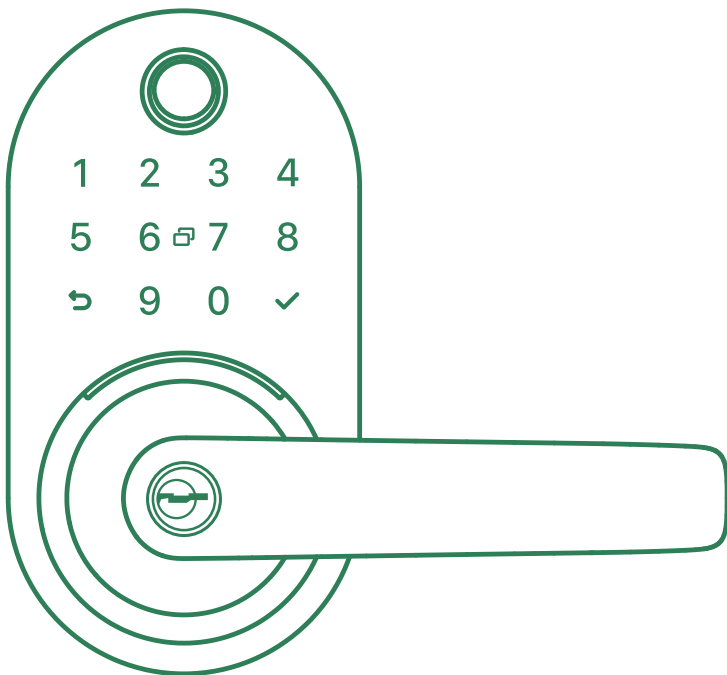

Model: YR01



**YAMIRY**

# WELCOME TO YAMIRY FAMILY

## TABLE OF CONTENTS

<b>Contact YAMIRY Support</b>	<b>2</b>
<b>1 Product Overview</b> .....	<b>3</b>
<b>2 Packing List</b> .....	<b>4</b>
<b>3 Installation</b>	<b>5-10</b>
3.1 Preparing Door .....	5
3.2 Adjust Latch Backset Length .....	5
3.3 Install Latch and Strike & Strike Box .....	6
3.4 Adjust the Handles Direction .....	7
3.5 Install Exterior Assembly .....	8
3.6 Install Interior Assembly .....	9
3.7 Installing Batteries .....	10
<b>4 User Guide</b>	<b>10 - 16</b>
4.1 System Initialization .....	10
4.2 Download the Nice Digi App .....	10
4.3 Sign-up and Login Your Account .....	11
4.4 Pair the lock with APP .....	11
4.5 User Management .....	11-16
<b>5.Using Your Lock</b> .....	<b>17 - 18</b>
<b>6.FAQs</b>	<b>19</b>

## IMPORTANT NOTES

Install and test the lock with the door open to avoid being locked out.

Please read all the instructions before contacting customer support.

Please contact customer support before returning the product to the store.

DO NOT install the batteries before installing the lock!

Follow the instructions in sequential order!

Please must use AA Alkaline Battery and don't use Lithium Battery or Rechargeable Battery.

## YAMIRY TERMS & POLICIES

Before use all YAMIRY products, please read all applicable terms, rules, polices and usage provision found at [www.yamiry.com/pages/privacy](http://www.yamiry.com/pages/privacy). By using your YAMIRY products, you agree to be bound by the YAMIRY Privacy Policy.

## NEED HELP?

Support Email: [support@yamiry.com](mailto:support@yamiry.com)

For technical documents and more  
Please visit <https://www.yamiry.com/pages/support-yr01>

# 1 Product Overview

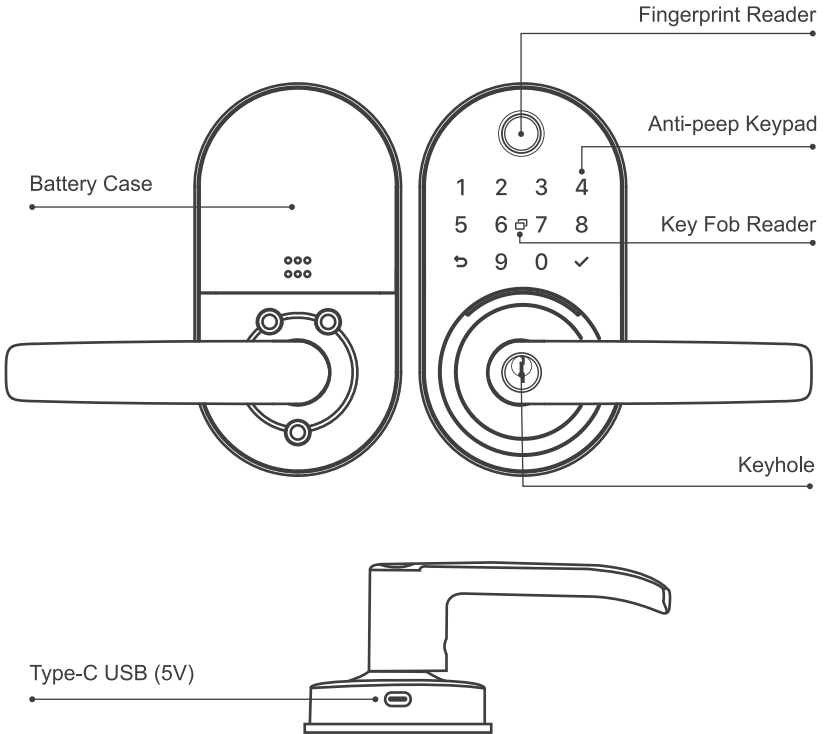

## Fingerprint Reader

Used to verify your finger and unlock from outside.

## Key Fob Reader

Used to read the key fob and unlock from outside.

## Keyhole

Used to insert key to unlock in emergency situations.

## Anti-peep Keypad

Used to enter the code and unlock from outside.

## Manual Lock Key (✓)

Press and hold the "✓" for 3 seconds to manually lock from the outside

## Type-C USB (5V)

Used to connect power bank to activate the lock when battery runs out.  
(It can't be used to charge the lock)

## 2 Packing List

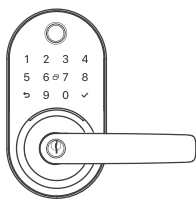

Exterior Assembly \* 1

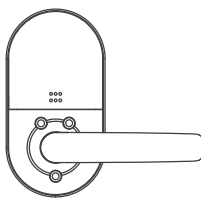

Interior Assembly \* 1



User Manual \* 1



Rubber Plate \* 2

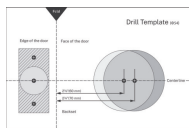

Punch Diagram \* 1



Mechanical Key \* 2

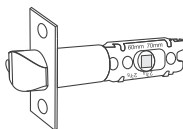

Latch \* 1

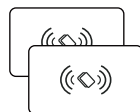

Key Fob \* 2

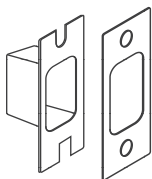

Strike & Strike Box \* 1



Square Shaft \* 1

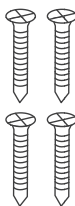

Screw A \* 4

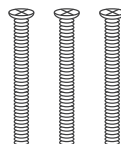

Screw B \* 3



Positioning Column \* 2

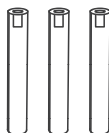

Screw Casing \* 3



Pin \* 1



LShape Allen Wrench \* 1





## 3 Installation

Please scan this QR code to watch the easy step by step installation video before attempting to install your Smart lock.



### 3.1 Preparing Door

 Check the door's dimensions

-  Measure to confirm that the door is between 1-3/8in to 2 in(35mm-50mm)thick.
-  Measure to confirm that the hole in the door is 2-1/8in(54mm).
-  Measure to confirm that the door is between 2-3/8in OR 2-3/4in(60mm OR 70mm) thick.
-  Measure to confirm that the hole in the door edge is 1in(25mm).

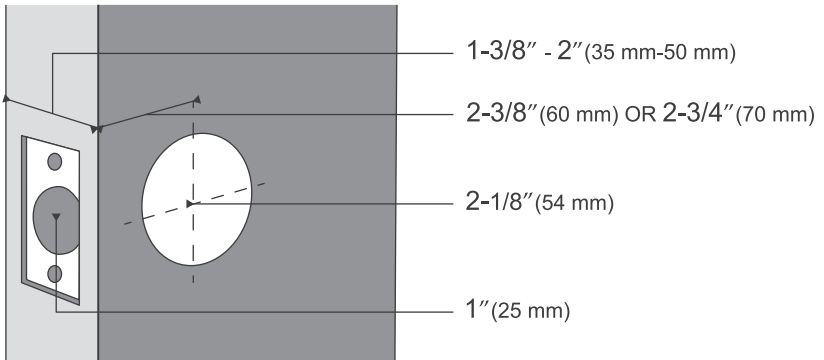

### 3.2 Adjust Latch Backset Length

Measure your door backset, then adjust to the corresponding latch length.

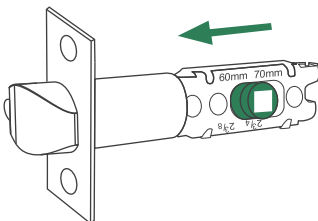

2-3/8" (60mm)

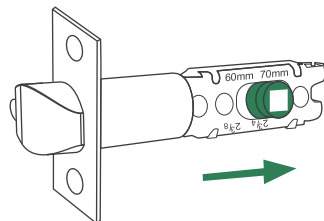

2-3/4" (70mm)

### 3.3 Install Latch and Strike & Strike Box

- 1 Install strike & strike box on door frame with Screw A.
- 2 Install latch into door with Screw A.

(Tips: For optimal coordination with the locking mechanism, please replace your existing latch with the included one.)

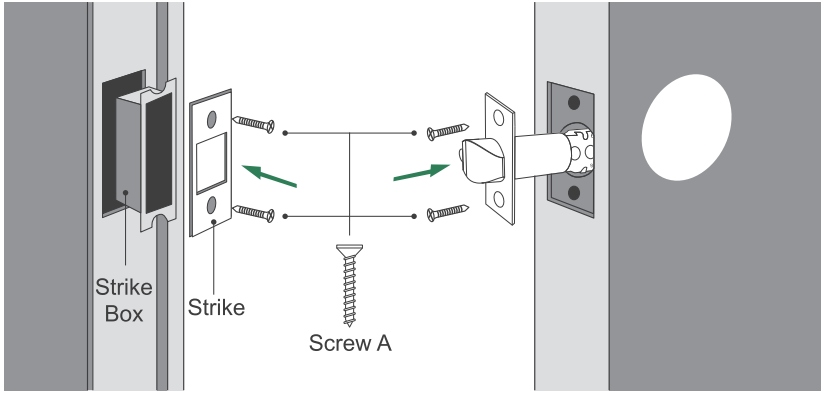

## Attention | Check Latch's Status

- 1) Both sides of the latch's square holes should place horizontally.
- 2) If the square hole of the latch is inclined, smart lock will get stuck during unlocking and fail to function properly.

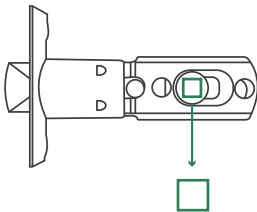

Correct: Horizontal

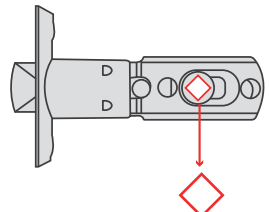

Error: Inclined

## 3.4 Adjust the Handles Direction

- 1 Confirm the opening direction of your door.
- 2 Adjust Handles According to Door Opening Direction.

### Left-Handed Door

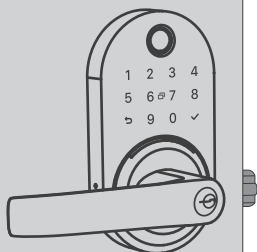

### Right-Handed Door

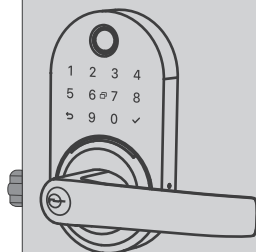

#### 1. For Exterior Assembly

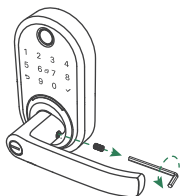

##### Step1 :

Loosen the screw with a 3mm Allen wrench (Included)

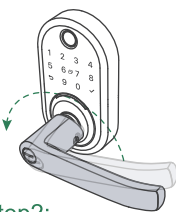

##### Step2:

Turn the handle to adjust the direction

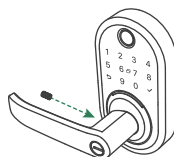

##### Step3:

Tighten the screw after adjusting the handle direction and complete.

#### 2. For Interior Assembly

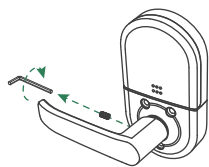

##### Step1 :

Loosen the screw

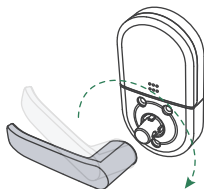

##### Step2:

Remove the handle to adjust the direction

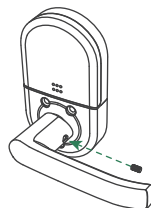

##### Step3:

Tighten the screw after adjusting the handle direction and complete.

## 3.5 Install Exterior Assembly

- 1 Install the waterproof rubber plate to exterior assembly.
- 2 Install square shaft into spindle hub.
- 3 Install 2 positioning columns.
- 4 Install 3 screw casings.
- 5 Install exterior assembly

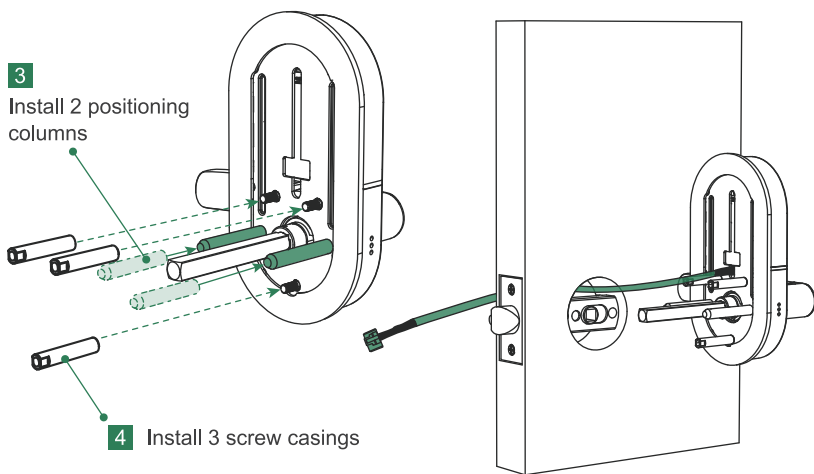
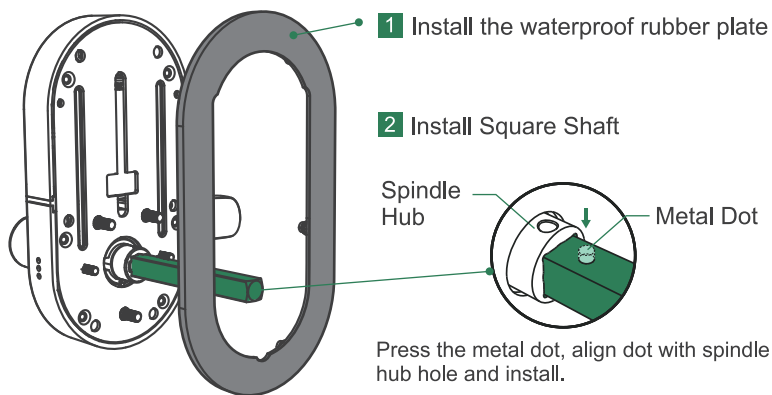

- 5** Install exterior assembly

### 3.6 Install Interior Assembly

- 1 Install the waterproof rubber plate.
- 2 Connect the cable.
- 3 Secure interior assembly with screw B.

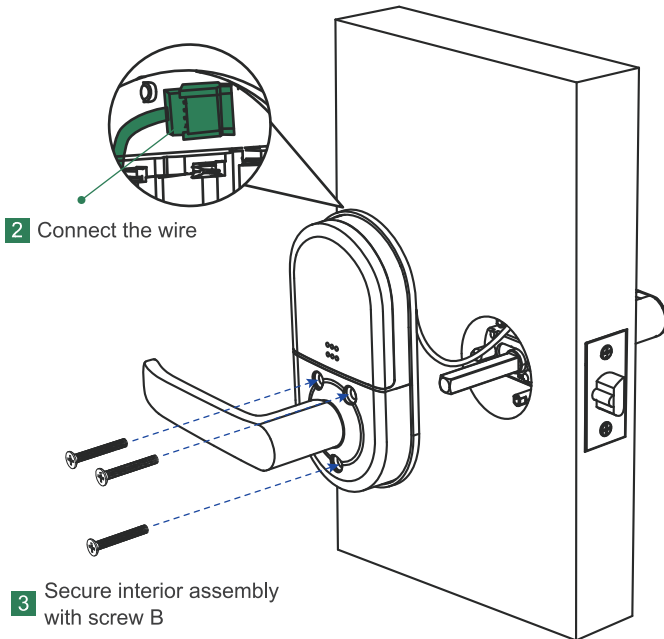
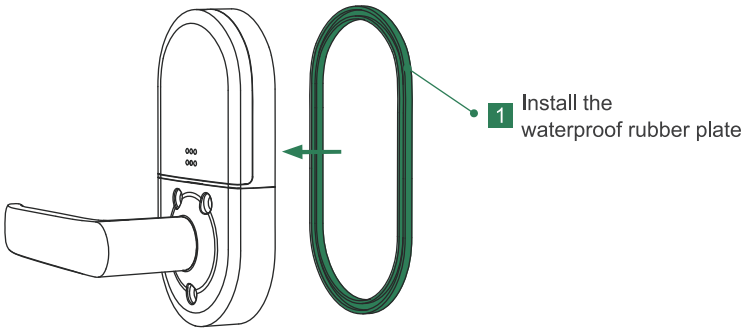

## 3.7 Installing Batteries

- 1 Insert 4 AA alkaline batteries.
- 2 Install the battery cover.
- 3 Installation complete.

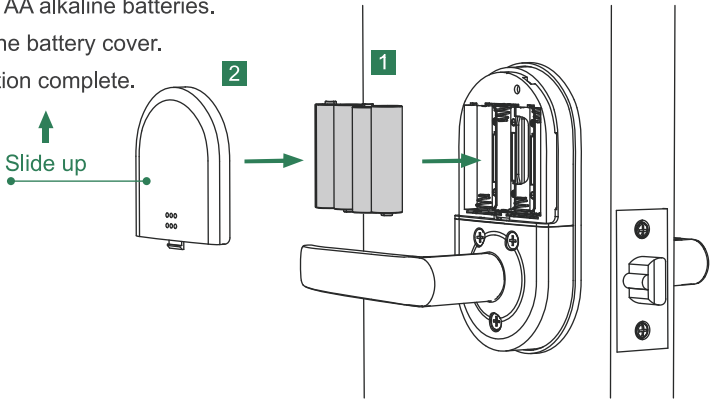

## 4 User Guide

Please scan this QR code to watch the simple step by step User Guide video to set up your smart lock.



### 4.1 System Initialization

- 1 Open the battery cover and make sure that batteries are installed and working.
- 2 Press and hold the Reset button for more than 5 seconds, release the reset button immediately upon hearing a "beep" sound.

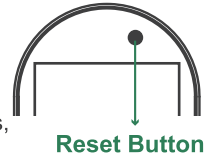

Then you will hear a voice prompt "Initialization successful", reset completed.

**⚠** If the reset button is held for more than 8 seconds or not released promptly upon hearing a "beep" sound, the reset will fail.

- 3 Complete the initialization, and start to pair the lock with Nice Digi APP .

### 4.2 Download the NICE DIGI App

Scan the Nice Digi QR Code to download the app or search "Nice Digi" in APP Store (IOS) and Google Play (Android) for download.



NICE DIGI QR Code

## 4.3 Sign-up and Login Your Account

Register a new account (Email Address) or log in with an existing account.

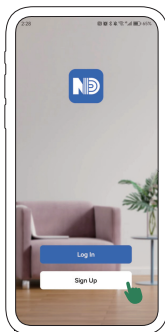

4-1

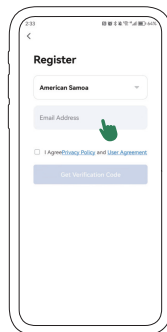

4-2

## 4.4 Pair the lock with APP

- 1 Turn on Bluetooth on your smartphone and stay near the lock (within 3 meters).
- 2 Click **"Add Device"** on the App, touch the door lock keypad to light it up, and wait to search for the device. (Refer to pictures 4-3 & 4-4)
- 3 Click on **"Add"** when the device is discovered.
- 4 Rename your lock. (Refer to Picture 4-6)
- 5 Pair the lock successfully, then start to control it with your App.



**Caution:** 1 It is necessary to light up the door lock keypad during step 3.

2 Please authorize if the app prompts to allow "Nearby Device" permissions.

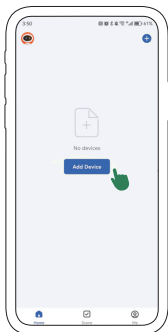

4-3

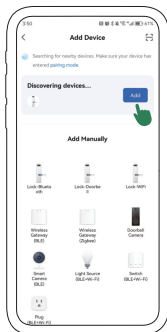

4-4

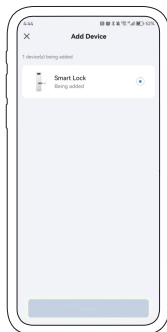

4-5

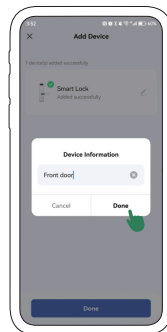

4-6

## 4.5 User Management

### 4.5.1 Unlock & Lock via Bluetooth

- 1 Long press the icon **"🔒"** to unlock or lock.
- 2 The distance between your phone and the lock should be within three meters.



## 4.5.2 Share Access Permission With Members

### 4.5.2.1 Add New Members

1 Touch **"Member"** on App.

2 Click the **"+"** at the top right to name the member.

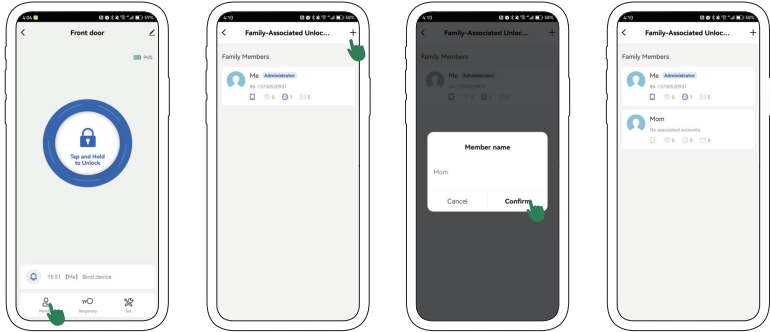

### 4.5.2.2 Add Member Passcodes

1 Touch **"Member"** on App.

2 Click the member you want to add a passcode.

#### **Warm Tips:**

- For privacy protection, the generated password will not be displayed on the App, please save it when generating.
- Don't forget to input confirm key "✓" after the passcode for final confirmation when unlocking.

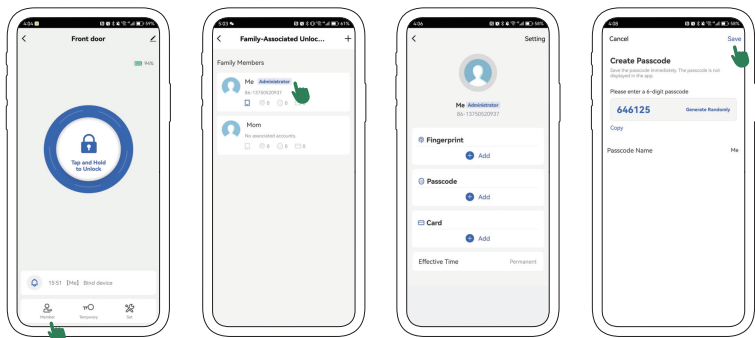

### 4.5.2.3 Add Key Fob

- 1 Touch **"Member"** on App.
- 2 Click the member you want to add a key fob.
- 3 Place a key fob on lock keypad and read it once to complete the enrollment.

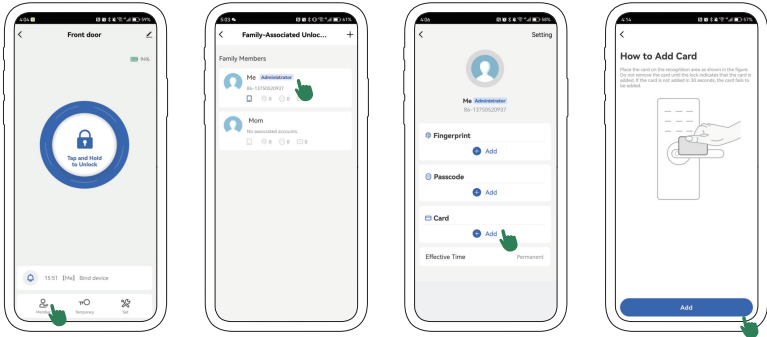

### 4.5.2.4 Add Fingerprint

- 1 Touch **"Member"** on App.
- 2 Click the member you want to add a Fingerprint.
- 3 Place your finger on the fingerprint reader as prompted by the App.

#### **Warm Tips:**

For the elderly and children or people with lighter fingerprints, create more fingerprint files and enter different angles of their fingerprints, which will help improve the fingerprint recognition rate.

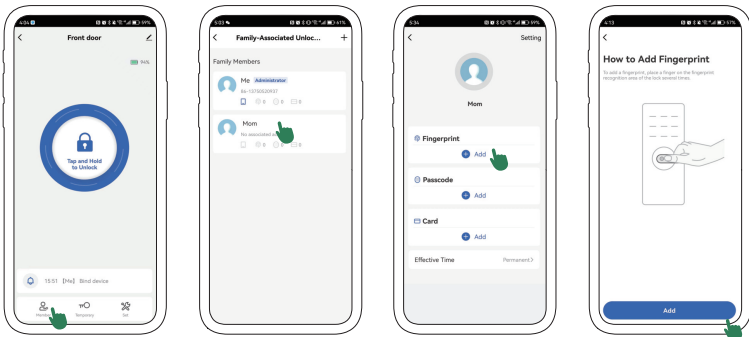

## 4.5.2.5 Authorize APP Permission

- 1 Select the member you want to authorize APP permission, click **"Setting"** on the top right to bind the new member's account.
- 2 Choose to authorize as Administrator or Common Member together to manage the lock.
- 3 The authorized user needs to accept the invitation on their app.  
Open the app, click to accept directly, (Refer to pictures 4-7)  
or check it in the message center, (Refer to pictures 4-8 & 4-9)  
(The members must be download the App and registered an account first).

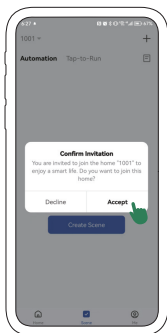
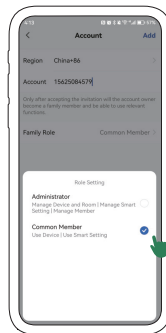
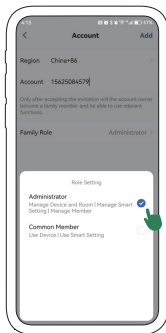
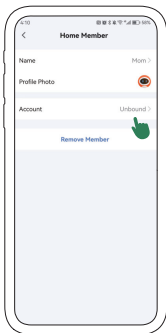
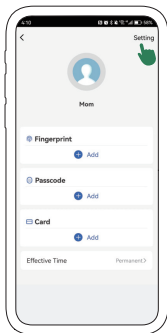

4-7

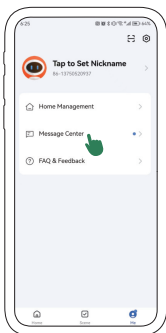

4-8



4-9

### 4.5.3 Generate Temporary Passcode

Touch **“Temporary”** to add a user code. There are 3 different passcode types to choose from.

You can enter the passcode you generated on the door lock keypad.  
Please do not forget to enter **“√”** after the passcode to confirm the unlocking.

**⚠ Notes:** To protect privacy and security, the passcode will not be displayed on the app. Please save your passcodes in time.

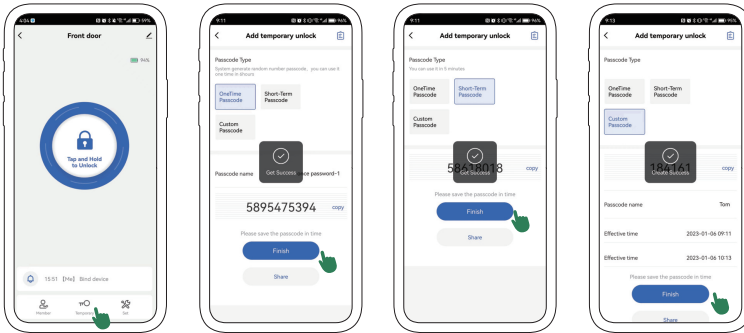

### 4.5.4 Unlock Record

1 Click on the display box at the bottom of the app home page to view the user's records. You can select the records you need to find based on time, operation, and user.

2 Update door lock records

- (1) Your phone near to the lock with Bluetooth communication distance(3 meters). Then you can update and view all unlocking records;
- (2) Beyond the Bluetooth distance, you need to connect the extra Wi-Fi Gateway (YAMIRY sold separately) to remotely update and view all unlocking activities of the door lock.

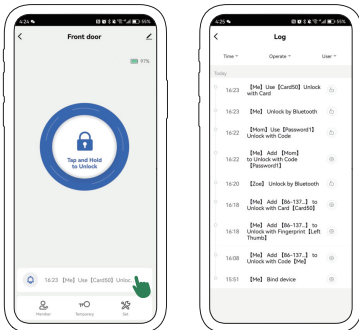

## 4.5.5 Remote Unlock via WiFi (Option)

1 To remotely control your lock via the app from anywhere or work with Alexa and Google Home to voice control smart lock, you need to connect your smart lock with a WiFi gateway (gateway sold separately) first.

2 Remote unlocking is enabled by default. If you have connected the gateway, ensure that remote unlocking is enabled before unlocking remotely.

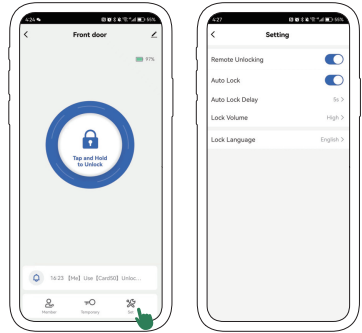

## 4.5.6 Manage multiple locks for your Airbnb

If you manage multiple locks for your Apartment or Airbnb, we suggest that you can create a separate home for each of your rooms or houses. It will help you better manage each of your rooms or houses and grant permissions to each of your tenants.

- 1 Return to the homepage, Find **"Me"**, and click **"Home Management"**.
- 2 Create a home, and return to the home page after the name is successful.
- 3 Click the drop-down box on the upper left to switch between different families.

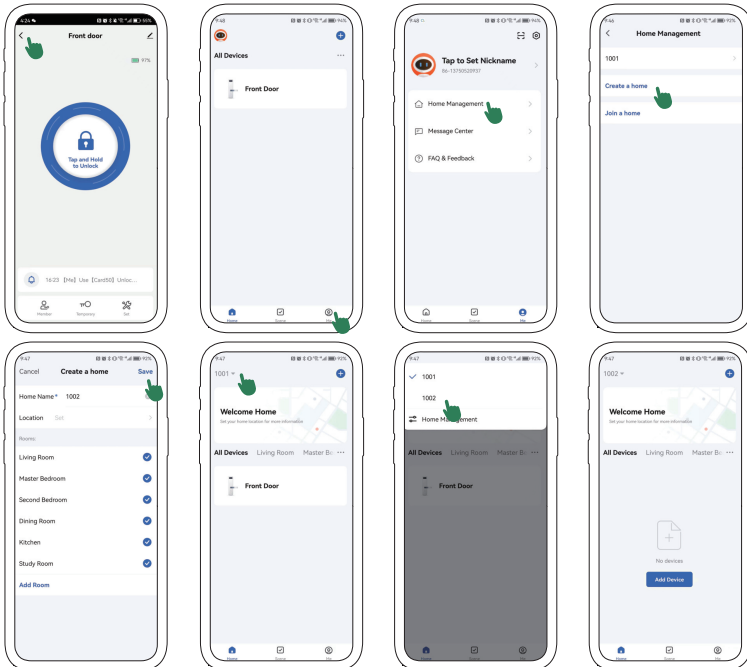

# 5.Using Your Lock

## 5.1 Unlock From Outside

### 1.Fingerprint

Place your finger on fingerprint reader to unlock.

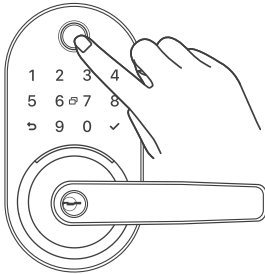

### 2.User Code

Enter your code and press "✓" to unlock.

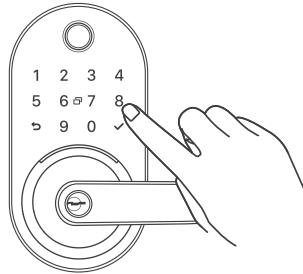

### 3.Key Fob

Swipe your key fob on the keypad of the lock to unlock.

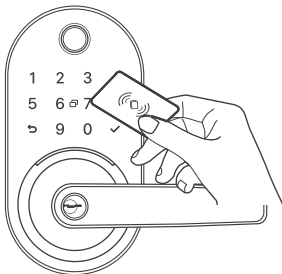

### 4.Smartphone

Use your smartphone to unlock.

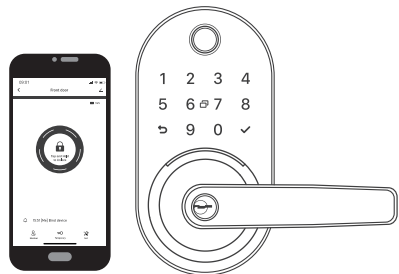

## 5.2 Reset the Lock

Please note that resetting the lock will erase all data on the lock. After resetting the lock, you need to re-pair and program the lock with the app.

1 Electronic Reset: Only the administrator of the lock has permission to reset the lock in the app. (Refer to following picture 1-3)

2 Manual Reset: Press and hold Reset button for more than 5 seconds, release the reset button immediately upon hearing a "beep" sound. (Refer to Page10 Section 4.1 System Initialization)

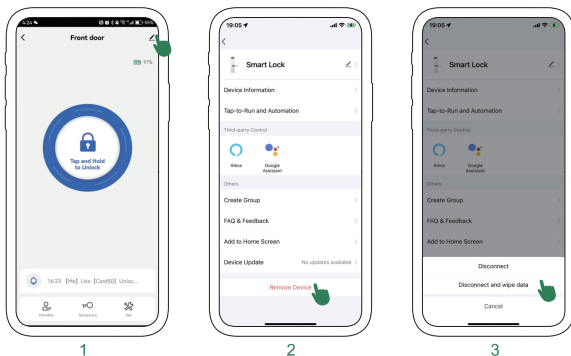

## 5.3 Replace Batteries

Please use 4 high-quality alkaline AA batteries for replacement when the battery is dead.

## 5.4 Emergency Power 5V

Type-C USB interface is used to connect regular 5V power bank to activate the lock in case the battery is dead.

**Note:** The Type-C USB interface is only used for emergency unlock and cannot be used for battery charging.

## 5.5 Anti-peep Passcode

- Anti-peep passcode allows users to enter random digits before and after the user code.
- The user password consists of 6 to 9 digits, and the total password length, including any random digits, does not exceed 16 digits.
- For example, your user code is **123456**, the total passcode that the user enters could be **789123456543**, the system would recognize "**123456**" as the correct user code and grant access.

# FAQ

## 1. Is there any other way to lock it from the outside?

**In addition to using apps, automatic locks, and keys, any else?**

A: Press and hold the ✓ key for 3 seconds to manually lock it from the outside.

## 2. Why can't I search for the lock on the App when I'm pairing it?

A: Please complete the initialization of the lock before pairing it. Connect to Network or WiFi, and turn on your phone's Bluetooth within 3 meters of the lock. Please check if the required permissions are authorized for the app. And touch the keypad to wake the lock during the operation.

## 3. How can I unlock the door if the batteries run out?

A: Insert a Type-C USB cable into the port as emergency power.  
And then you can unlock the door and replace the batteries.  
Please do not power smart locks through the Type-C USB port.

## 4. Why can't two people's apps connect to one lock at the same time?

A: If two apps only use Bluetooth to manage one lock at the same, only one user can connect to control this lock. And the Bluetooth will be automatically disconnected in the following 3 cases:

- 1) Exceeds Bluetooth communication distance.
- 2) The APP switches to the background more than 1 minute.
- 3) Directly close the APP.

But if you connect the gateway (Not Included) to unlock it, you can be online at the same time.

## 5. Why does the lock always indicate a low battery, even when I get a new battery?

A: Please use the new AA Alkaline Battery and install it in the correct direction.

Sometimes there will be inaccurate readings after replacing batteries, which does not affect your normal use. Generally, it will return to correct after using the App to unlock several times.

## 6. How can I unlock the door if the smart lock doesn't work?

A: You can use the mechanical key to unlock.

---

# YAMIRY

If there are any issues with products,  
please contact tech support:

**support@yamiry.com**