

CREATE REALITY, ACHIEVE DREAMS

Ender-3 Neo

Ender-3 Neo

3D Printer User Manual

V1.4

To Our Dear Users

Thank you for choosing Creality. For your convenience, please read through this User Manual before you start and follow the instructions provided carefully.

Creality is always ready to provide you with high-quality services. If you encounter any issues or have any questions when using our products, please use the contact information at the end of this manual to contact us. To further improve your user experience, you can find more about our devices via the following methods:

User manual: You can find instructions and videos in the memory card provided with the printer.

You can also visit our official website (<https://www.creality.com>) to find information regarding software, hardware, contact information, device instructions, device warranty information, and more.

Firmware Upgrade

Please visit our official website <https://www.creality.com/download>. Click Homepage → Support → Download.

Download the required firmware and install it.

- 1 Do not use this printer by methods or operations that are not described in this manual, otherwise it may result in accidental injury or property damage.
- 2 Do not place this printer near flammable materials, explosive materials or high heat sources. Please place this printer in a ventilated, cool and low-dust environment.
- 3 Do not place this printer in a vibrating or any other unstable environment, as the printing quality will be compromised when the printer shakes.
- 4 Please use the filament recommended by the manufacturer, otherwise the nozzle may be clogged or the printer may be damaged.
- 5 Please use the power cord provided with the printer and do not use the power cord of other products. The power plug must be plugged into a three-hole socket with a ground wire.
- 6 Do not touch the nozzle or hotbed while the printer is in operation, otherwise you may get burned.
- 7 Do not wear gloves or accessories while operating the printer, otherwise the moving parts may cause accidental injury including cuts and lacerations.
- 8 After the printing process is complete, please use tools to clean up the filament on the nozzle while the nozzle is still hot. Do not touch the nozzle with your hands when cleaning, otherwise your hands may get burned.
- 9 Please regularly clean the printer body with a dry cloth while the power is off, and wipe off dust, sticky printing materials, and foreign objects on the guide rails.
- 10 Children under the age of 10 must not use this printer without adult supervision in order to avoid accidental injury.
- 11 This printer has a safety protection mechanism. Please do not manually move the nozzle or printing platform quickly while the printer is on, otherwise the printer will automatically power off for protection.
- 12 Users should abide by the laws and regulations of the corresponding country and region where the equipment is located (place of use), abide by professional ethics, and pay attention to safety obligations. The use of our products or equipment for any illegal purpose is strictly prohibited. Our company is not responsible for the relevant legal responsibilities of any violators.

About the Printer	01-01
Device Specifications	02-02
List of Parts	03-04
Installing the 3D Printer	05-12
On-screen information	13-13
Auxiliary leveling	14-14
Auto Leveling	15-15
Filament infill	16-17
Start Printing	18-19
Circuit Wiring	20-20

1. About the Printer

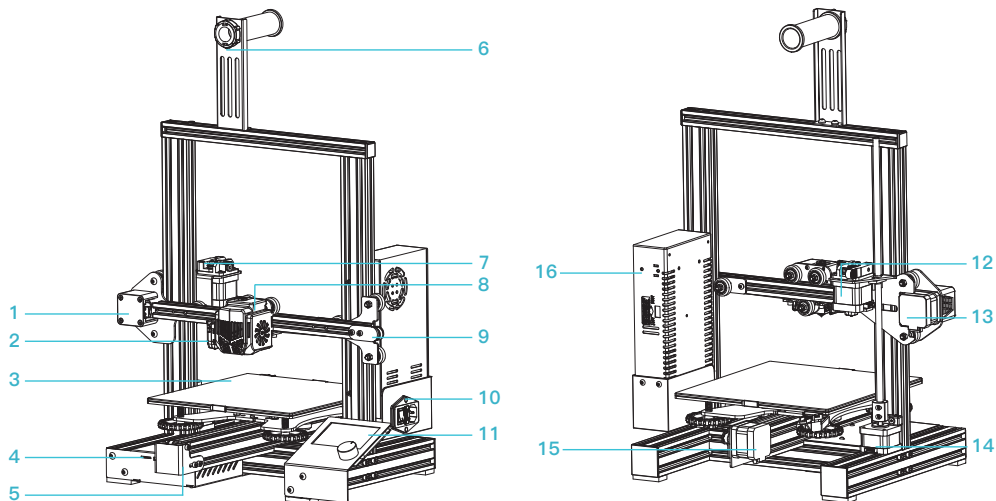

1 X-axis limit switch

2 CR-Touch

3 Printing platform

4 Storage card slot

5 Y-axis tensioner

6 Material rack and material barrel

7 Extrusion kit

8 Nozzle kit

9 X-axis tensioner

10 Power switch and socket

11 Screen

12 E-axis motor

13 X-axis motor

14 Z-axis motor

15 Y-axis motor

16 Power supply module

2. Equipment Parameters



General Specifications	
Model	Ender-3 Neo
Modeling Dimensions	220*220*250mm
Modeling Technology	FDM
Number of Nozzles	1
Slice Thickness	0.1mm-0.35mm
Nozzle Diameter	0.4mm (standard)
Precision	±0.1mm
Printing Material	PLA/ABS/PETG
Supported File Format	STL/OBJ/AMF
Printing Method	TF card/USB on-line printing
Supported Slicing Software	Creality Slicer/Cura/Repetier-Host/Simplify3D
Rated Voltage	100-120V~ 200-240V~ 50/60Hz
Rated Power	350W
Heated Bed Temperature	≤100°C
Nozzle Temperature	≤260°C
Power Loss Recovery	Yes
Auto Leveling	Yes
Language	English/中文/ Español/ Deutsche/ Français/ Русский/ Português/ Italiano/ Türk
PC Operating Systems	WIN/MAC/Linux
Printing Speed	≤120mm/s

3. Parts List

Parts List

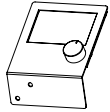

1 Screen

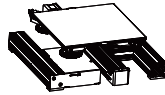

2 Base component



3 Power supply module



4 Z-axis passive block



5 Nozzle kit



6 Extrusion kit

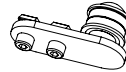

7 X-axis passive block

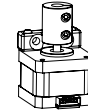

8 Z-axis motor component



9 Material barrel



10 Material rack

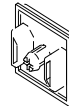

11 2020 profile cover



12 Z-axis profile (Right)



13 Z-axis profile (Left)



14 Top gantry profile



15 X-axis profile



16 T-type screw rod

Note: The components above are for reference only. The actual product shall prevail.

3. Parts List

Tool list



17 TF Card and Card Reader



18 Wrench and screwdriver

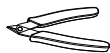

19 Cutting plier



20 Nozzle Cleaner



21 power cable



22 Blade



23 Blue clip×2



24 Nozzle



25 Quick release claw



26 Cable tie



27 X-axis timing belt



28 Filament



29 M5x8 Hexagon Socket Button Head Screw×4



30 M4x20 Hexagon Socket Head Cap Screw×2



31 M4x16 Hexagon Socket Button Head Screw (with spring washers)×4



32 M5x45 Hexagon Socket Head Cap Screws (with spring washers) ×4



33 M5 T nuts×2



34 M4x18 Flat Head Socket Cap Screw×2



35 M5x25 Hexagon Socket Head Cap Screws (with spring washers)×4

Note: The components above are for reference only. The actual product shall prevail.

4. Install the Printer

4.1 Assemble Z-axis profiles

Make sure that the Z-axis profile is perpendicular to the profile of machine base, placed in the slot of the base frame and flush with both left and right sides of the base profile, and tighten the four M5 x 45 screws from the bottom upwards.

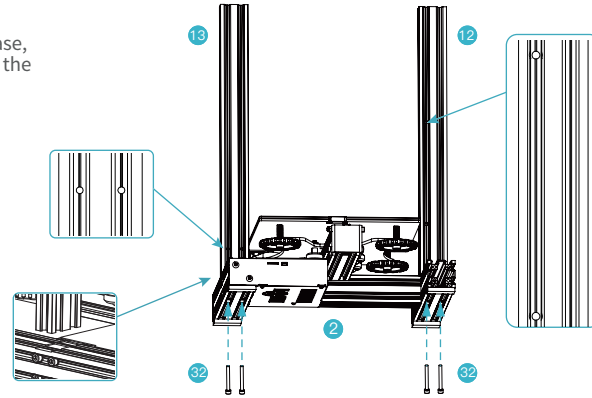

4.2 Install screen and power supply components

- A. Fix the power supply behind the right profile of the Z-axis, pre-lock it first with two M4 x 20 screws aligned with the holes and then tighten to secure it.
- B. Secure the display fixing plate to the base assembly using two M5 x 8 screws.

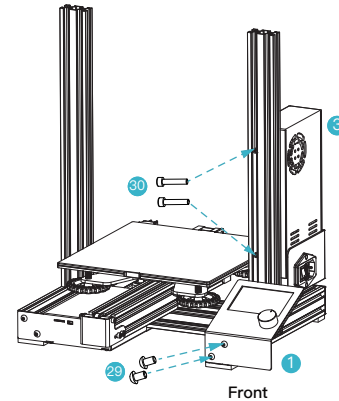

4. Install the Printer

4.3 Install Z-axis motor component and T-type screw rod

A. Insert the T-rod onto the Z-axis motor assembly and tighten to secure.

B. Lock the Z-axis motor assembly to the profile using two M4 × 18 screws.

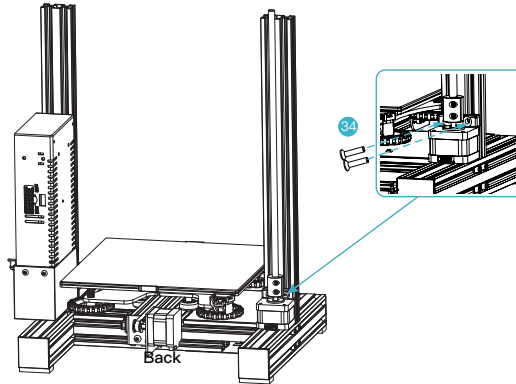
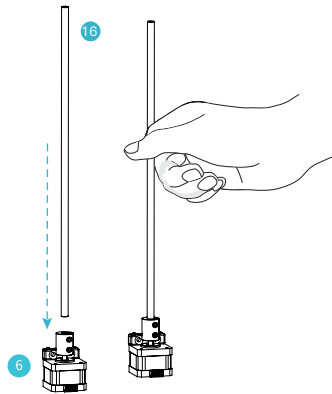

4.4 Install the extrusion kit

Fix the extrusion kit to the left end of the X-axis profile using two M4 x 16 screws.

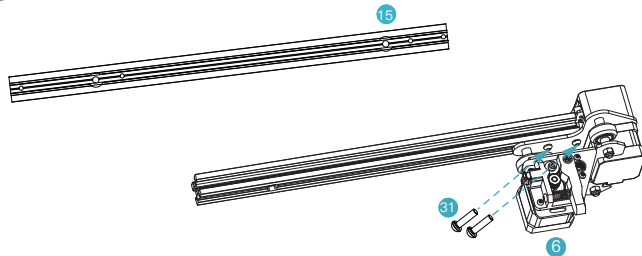

4. Install the Printer

4.5 Install the X-axis timing belt

Thread the X-axis timing belt through the XE-axis assembly. (As shown in the diagram below)

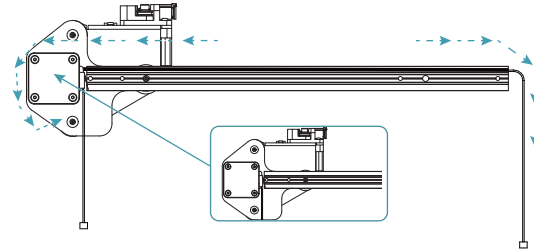
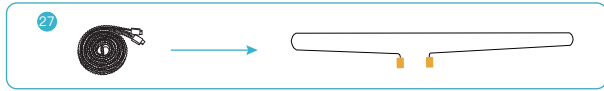

4.6 Install the nozzle kit

Slide the nozzle kit into the X-axis profile.

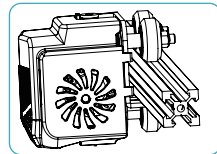
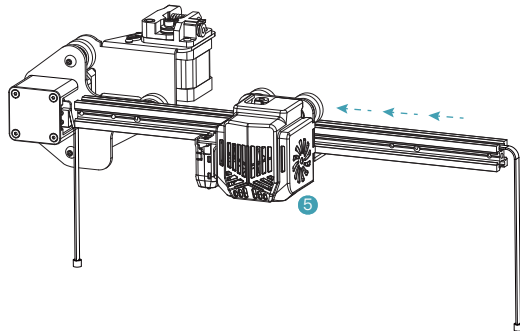

*Snap the V-wheels into the V-slot of the X-axis profile

4.7 Install Z-axis passive block

Fix the Z-axis passive block to the right end of the X-axis profile using two M4 x 16 screws.

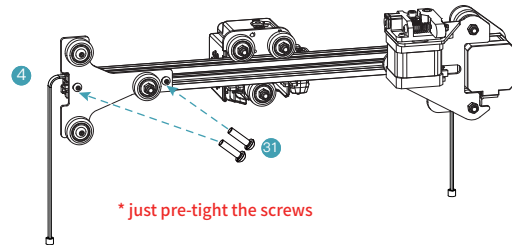

* just pre-tight the screws

4. Install the Printer

4.8 Install X-axis passive block

- A. Snap the brass sleeve on the left side of the X-axis timing belt into the extruder back support plate.
- B. Fix the X-axis passive block to the X-axis profile. (Be careful not to screw it down and make sure the X-axis passive block can slide along the X-axis profile.)
- C. After winding the X-axis timing belt around the X-axis passive block, snap the brass sleeve at its right end into the extruder back support plate.
- D. Push the X-axis passive block to the right to tension the X-axis timing belt to the same state as the Y-axis timing belt, then tighten the set screw on the X-axis passive block.

StepA

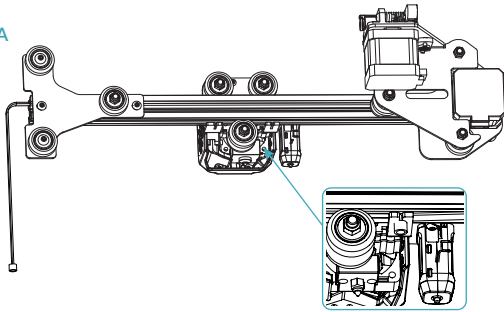

StepB

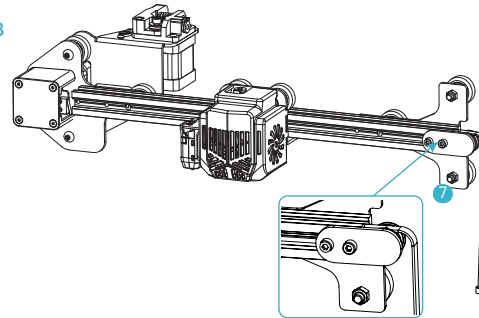

StepC

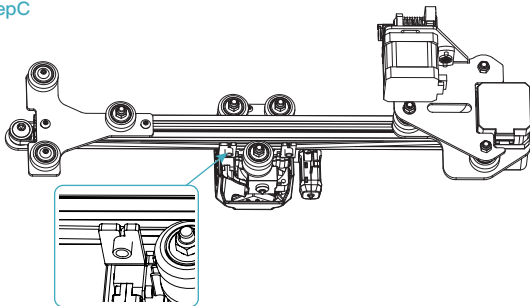

StepD

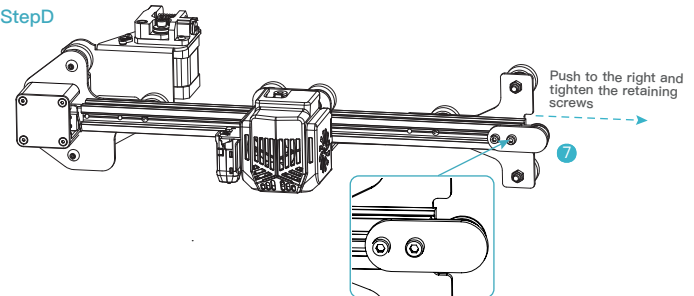

4. Install the Printer

4.9 Install the X-axis kit and adjust tightness

Fit the X-axis kit into the Z-axis profile, with the V-wheels on the left and right sides aligned with the slot in the profile and the T-rod nut aligned with the T-rod. (Note: The eccentric spacers on the left and right need to be adjusted if the left and right passive blocks cannot get in.)

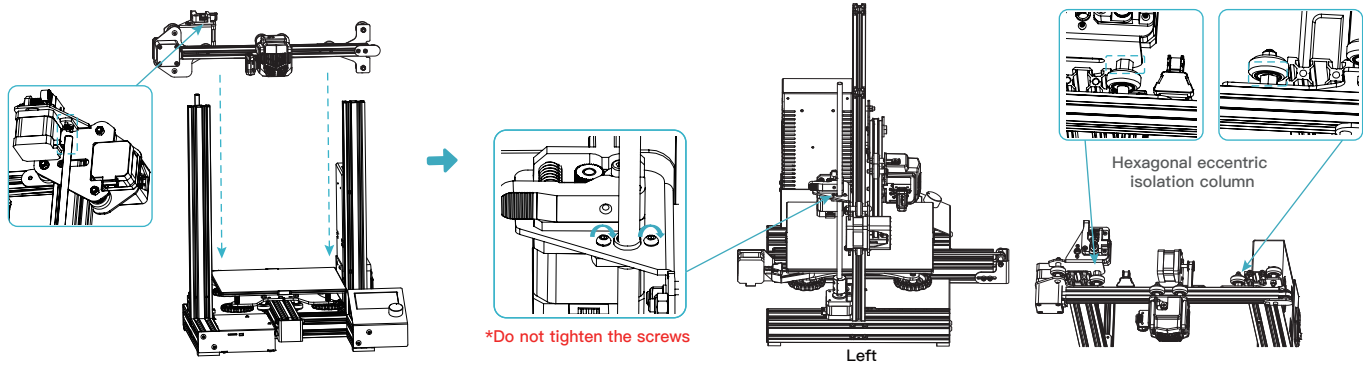

4.10 Install the top gantry profile and profile cover

- A. Secure the top gantry profile to the top end of the gantry with four M5 x 25
- B. Attach the profile covers to the ends of the top gantry profile.
- C. Tighten the two retaining screws on the Z axis passive block.

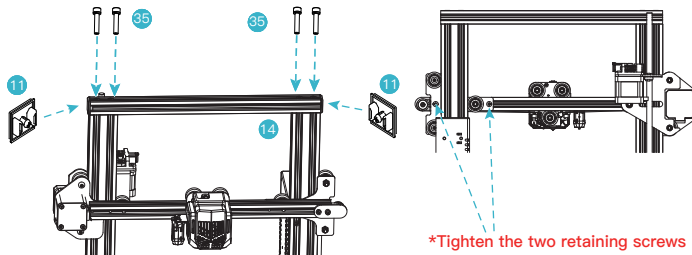

4.11 Install the material rack and barrel

- A. Assemble the material rack and barrel.
- B. Thread the two M5 x 8 screws through the material rack and then screw on the M5 T-nuts. (Note that there is no need to screw it down)
- C. Finally, fix those components to the top gantry profile.

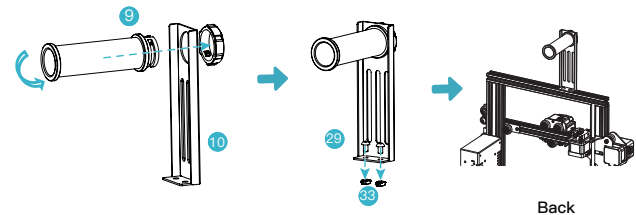

4. Install the Printer

4.12 Equipment Wiring



- A1. Follow the yellow label on the 6pin (4 wires) port to connect the X-axis stepper motor;
- A2. Follow the yellow label on the 6pin (4 wires) port to connect the E-axis stepper motor;
- A3. Follow the yellow label on the 6pin (4 wires) port to connect the Z-axis stepper motor;
- B. Follow the yellow label on the 3pin (2 wires) port to connect the X axis limit switch;
- C. Connect the mainboard power cable;
- D. Connect the display cable.



Caution

- Please ensure the correct position for the power supply switch and mains before supply connection , in order to avoid damage to the device.
- If the mains between 100V and 120V, please select the 115V for the power supply switch.
- If the mains between 200V and 240V, please select the 230V for the power supply switch(default is 230V).

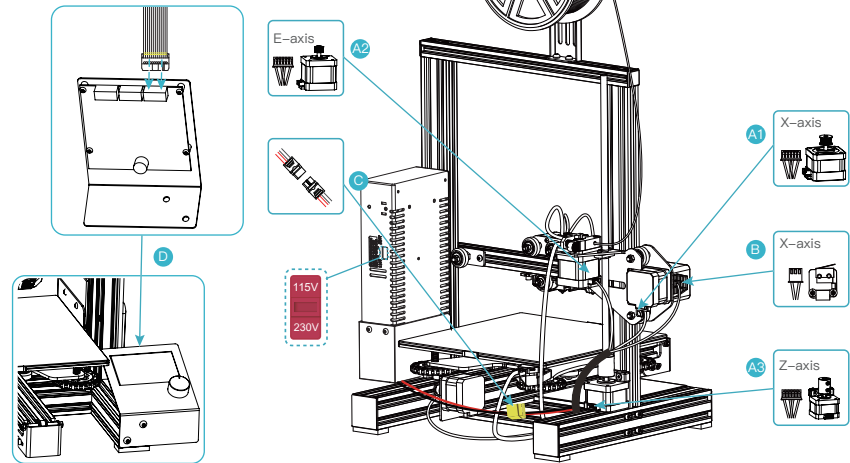

4.Install the Printer

4.13 Install the Teflon Tube



Quick release
claw



Wire clip (blue)

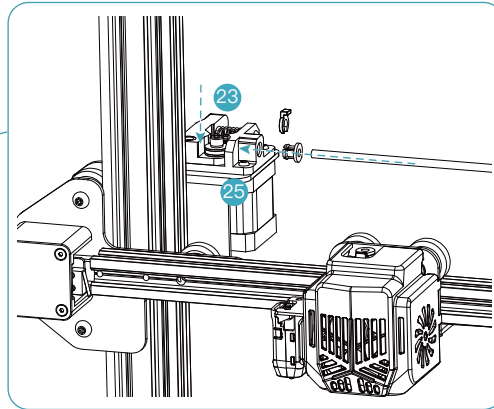
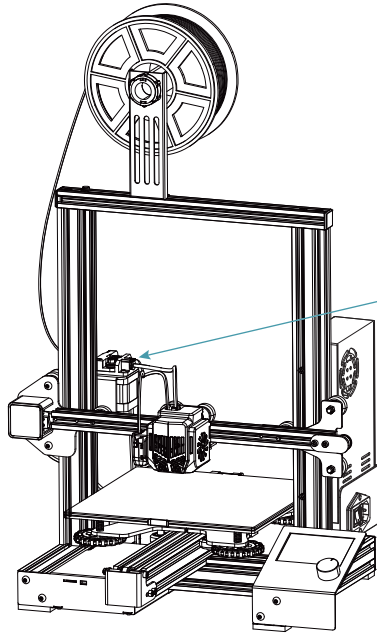

4. Install the Printer

4.14 Adjusting pulley tightness

Check the pulley looseness before switching on the machine.

X/Y/Z axis pulley adjustment: Gently turn the pulley to check whether it is idling or jammed. If this phenomenon occurs, use an open-end wrench to adjust the tightness of the hexagonal eccentric isolation column to make it rotate smoothly.

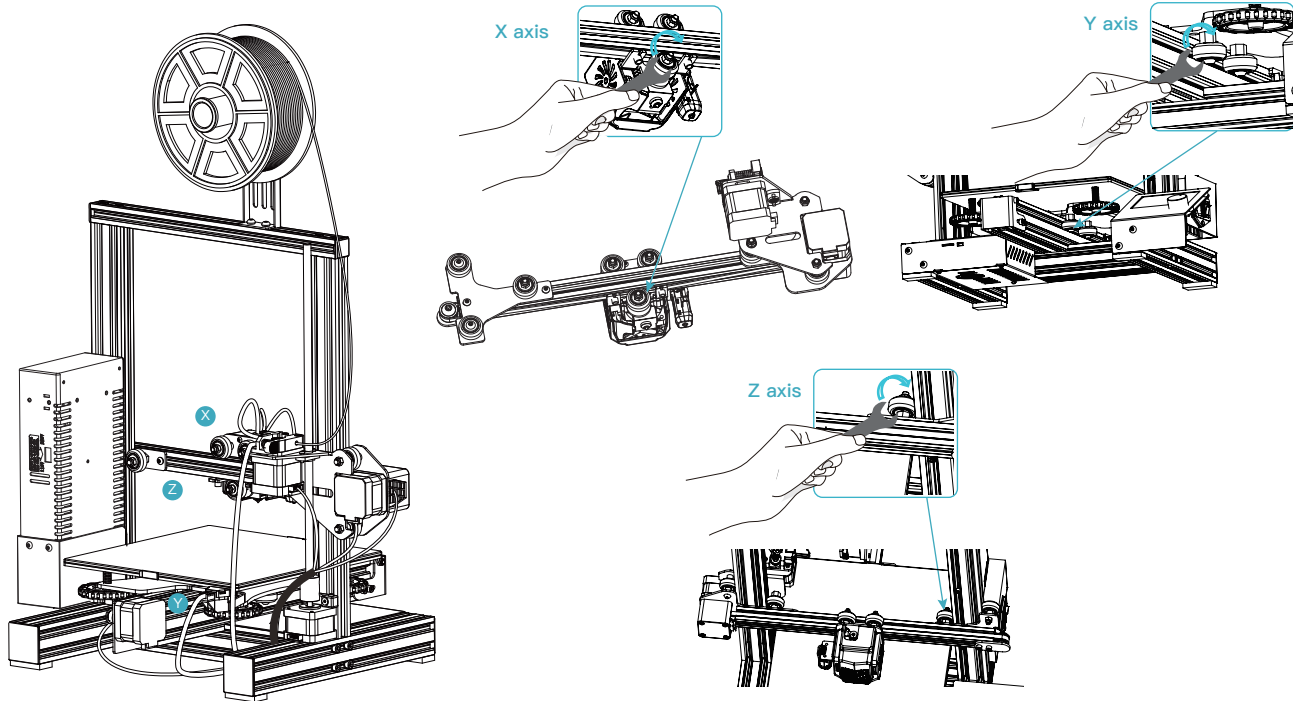

5. On-screen information

Displayed information

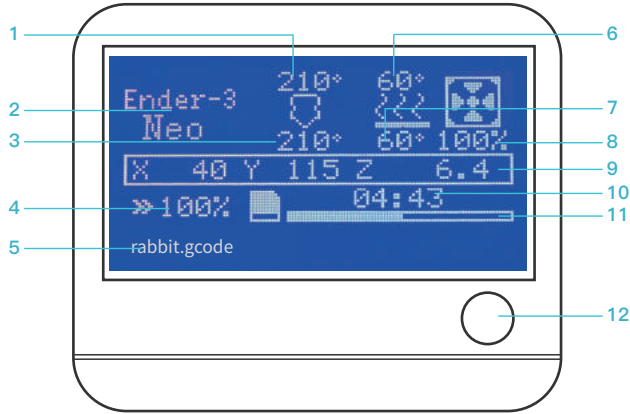

- | | | |
|---|----------------------|------------------------------|
| 1 Set nozzle temperature | 2 Model | 3 Current nozzle temperature |
| 4 Printing Speed | 5 Prompt | 6 Set heated bed temperature |
| 7 Current heated bed temperature | 8 Fan speed | 9 Current nozzle position |
| 10 Printing time | 11 Printing Progress | |
| 12 Press: Select OK
Rotation: Toggle option/Change value | | |

Info screen

	Moving Axis	Move X/Y/Z/Extruder
Motion	Auto home/Level Bed Z offset/Motor Off	
Temperature	Nozzle/ Bed/ Fan Speed/ Preheat PLA/ Preheat ABS	
Configuration	ADV.SET.	Set Home Offsets / Velocity / Acceleration / Jerk /Probe Offsets / Steps (mm) / Temperature / Fillament / Initialize settings
	Z offset	
	CR Touch	Reset / Self-inspection / Deploy/ Load / SW mode
	Recovery	
	Preheat PLA Conf / Preheat ABS Conf /	Fan Speed / Nozzle / Bed/ Save settings
Change Filament	Preheat PLA/ Preheat ABS/Preheat Custom	
Change TF card		
Print from TF card		
English		
About		

6. Auxiliary leveling

6.1 Info → Motion → Auto Home. (Waiting for the end of the CR-Touch detection platform)

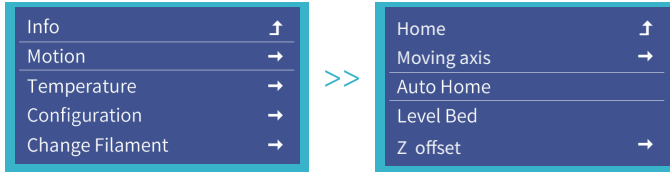

6.2 Info → Motion → Moving axis → Move Z. (Adjust the value to 0)

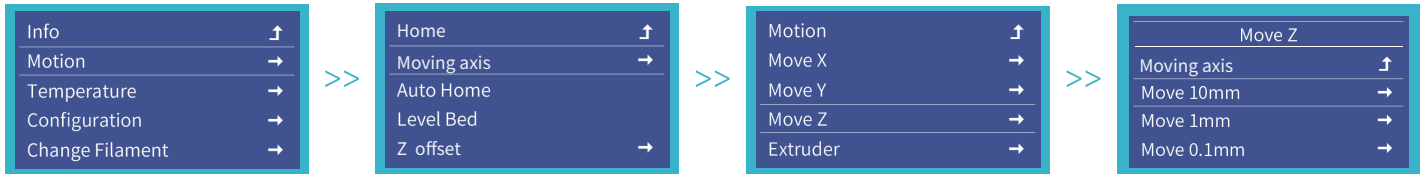

6.3 Info → Motion → Z offset. Observe the distance between the nozzle and the platform, ensuring the height of the nozzle to the platform is about the thickness of a piece of A4 paper (0.08–0.1 mm).

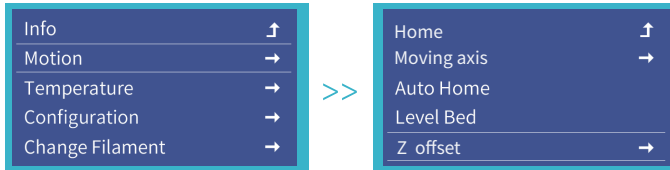

6.4 Info → Motion → Motor Off. Move the extruder above the four leveling knobs of the printing platform, and ensure that the height of the nozzle to the printing platform is about the thickness of a piece of A4 paper (0.08–0.1 mm). If needed, repeat the adjustment 1–2 times.

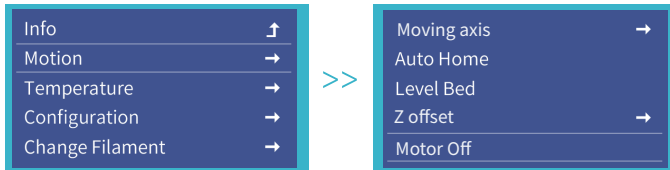

7.Auto Leveling

7.1 Info → Motion → Level Bed → Manually return to info screen.

The image shows a sequence of three screenshots. The first is a menu with 'Info' selected. The second is a menu with 'Level Bed' selected. The third is the LCD display showing sensor data for 'Ender-3 Neo' with coordinates X:40, Y:115, Z:6.4, 100% filament, and 04:43 time, with 'Sensing point 3/16' at the bottom.

7.2 Info → Configuration → Save settings. (Save Z-axis compensation data)

The image shows a sequence of two screenshots. The first is a menu with 'Configuration' selected. The second is a menu with 'Save settings' selected.



		⊗ The nozzle is too far away from the platform, and the filaments cannot stick to the platform.
		✓ Filaments are extruded evenly, just sticking on the platform.
		⚠ The nozzle is too close to the platform, leading to insufficient filament extrusion, even scraping the platform.

8. Filament infill



8.1 Preheating

Method 1

Info	↕
Motion	→
Temperature	→
Configuration	→
Change Filament	→



Change Filament	
Back	↕
Preheat PLA	
Preheat ABS	
Preheat Custom :	0

Method 2

Info	↕
Motion	→
Temperature	→
Configuration	→
Change Filament	→



Home	↕
Nozzle:	0
Bed:	0
Fan Speed:	0%
Preheat PLA	→



Nozzle:	200
---------	-----

8. Filament infill

8.2 Loading the Filament

- A. When you wait for the temperature to rise, hang the filament over the filament holder.
- B. Press the extrusion clamp and insert the filaments along the extruder hole up to the nozzle. When the temperature hits the target value, a flow of filaments can be seen at the nozzle, meaning that the filaments have been loaded.

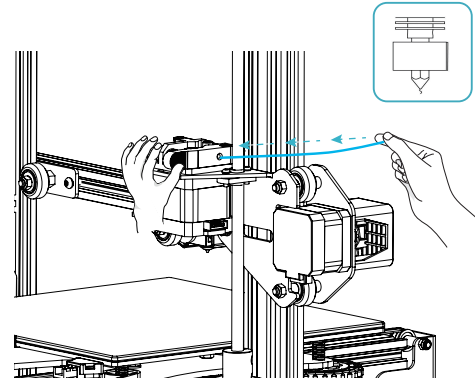
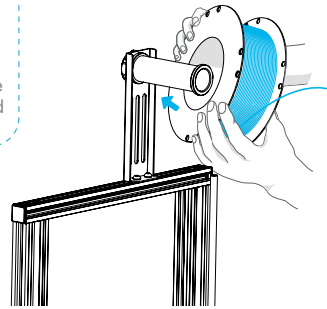
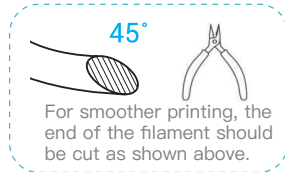

Replacing the filament:

1. When the printer is not under work:

- A. Heat the nozzle to above 185°C first, wait for the filaments inside the nozzle to soften, then press the extrusion handle and pull out the filaments quickly to prevent them from getting stuck at the heat break;
- B. Replace the new filaments onto the rack frame and repeat the loading procedure above.

2. When the printer is working:

- A. Suspend printing first and, once the printer has stopped, press the extrusion handle to pull the filaments out quickly and prevent them from getting stuck at the heat break;
- B. Replace the new filaments onto the rack, press the extrusion handle, insert the filaments through the extruder feed hole into the nozzle, then push the filaments hard to squeeze out the residual filaments from the nozzle, and clean it up for printing.

9.Start Printing



9.1 Download the Credulity software at www.credulity.com, or find it in the memory card and install it.

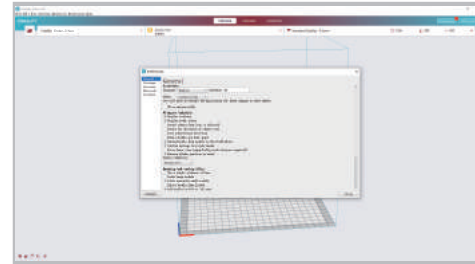

9.2 Select in turn Preferences → Basic → Select Language → Close to complete the settings.

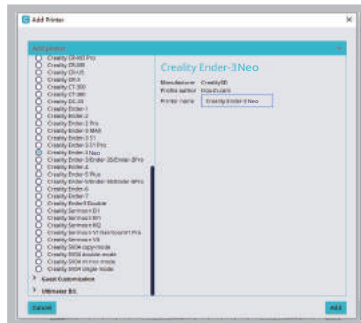

9.3 Select current model (Ender-3 Neo).

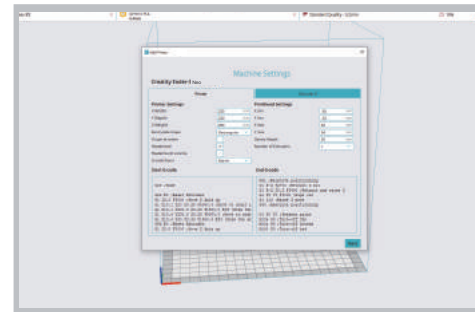

9.4 Enter Parameters → Close.

9.Start Printing



Creality Slicer

9.5 Open the Creality 3D Slicing Software.



9.6 Load (read the file).

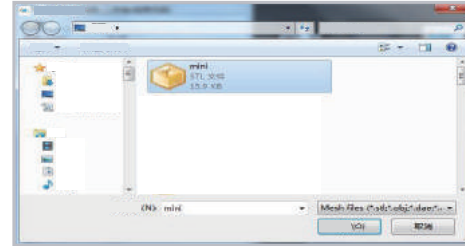

9.7 Select the file.

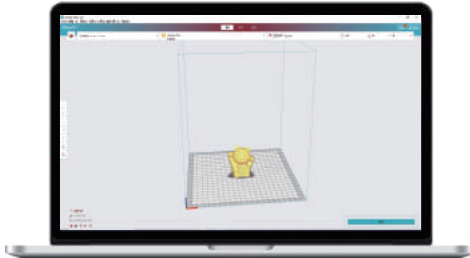

9.8 Generate the G-code file → Save it to the memory card.

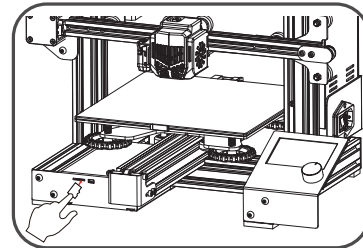

9.9 Insert the memory card → Press the screen knob → Select menu → The file to print.



The file name must only contain Latin letters and digits. Chinese characters or special symbols must not be used.



Note: For details on using the software please refer to the slicing software user manual on the memory card.

10.Circuit Wiring

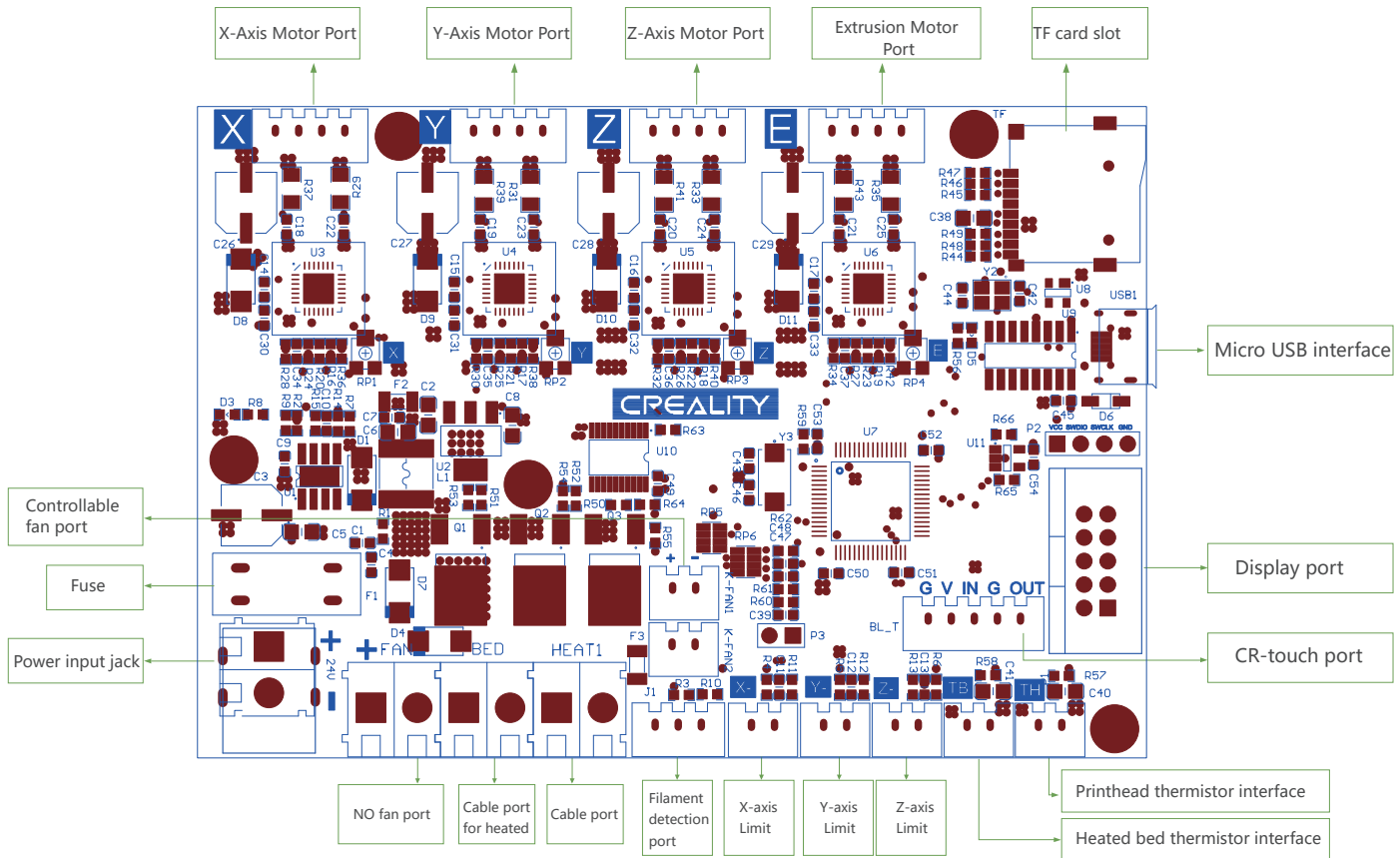

Due to the differences between different machine , the physical objects and the final images can differ .The final explanation rights shall be reserved by Shenzhen Creality 3D Technology Co.,Ltd



SHENZHEN CREALITY 3D TECHNOLOGY CO.,LTD.

18th Floor, JinXiuHongDu Building, Meilong Road, Xinniu Community,
Minzhi Street, Longhua District, Shenzhen City, China.

Official Website: www.creality.com

Tel: +86 755-8523 4565

E-mail: cs@creality.com

