

Flsun S1 Pro

Instruction Manual

Ultra High-Speed 3D Printing

1. Do not operate the machine according to methods other than those specified in the manual to avoid possible injury or property damage.
2. Do not place the printer near flammable, explosive or high heat sources, make sure that the printer is in a cool, dust free and well ventilated area.
3. Be careful touching the print bed, print nozzle, or other high temperature areas during or soon after use to avoid severe burns.
4. Do not reach inside the print area while the machine is in use to avoid injury from high speed movements.
5. Do not allow children or persons who have not read the instructions in detail to operate it alone to avoid personal injury or property damage.
6. Routine maintenance should be performed on the printer to ensure a long service life. The printer should be powered off before maintenance is performed, especially important on working parts such as the effector module and guide rails.
7. To ensure safe operation, always use a grounded power outlet.
8. If the printer is not going to be used for an extended period of time unplug the power cord.
9. Each printer is thoroughly tested before leaving the factory to ensure quality and functionality. It is normal to find evidence of prior use.
10. Visit the official FLSUN Wiki for more tutorials on machine use and maintenance: <http://wiki.flsun3d.com/en/home>.

PRODUCT		FLSUN S1 Pro
Printing Technology		Fused Deposition Modeling (FDM)
Printing Accuracy	± 0.1mm	
Recommended Layer Height	0.1-0.35mm	
Build Volume	ø320 * 430mm ³ (Maximum height of the cylinder: 383mm)	
Frame	Full Metal	
Product Dimensions	550*595*1030mm	
Package Dimensions	640*680*1120mm	
Net Weight	41kg	
Gross Weight	51kg	
Extruder	Dual-Gear Direct Drive Extruder	
Nozzle	Hardened Steel	
Nozzle MAX Temp	350°C	
Nozzle Diameter	0.4mm	
Filament Diameter	1.75mm	
Motor Types	36V Closed-loop motor	
Motor Calibration	Support	
Build Plate	Textured PEI Print Plate	
Bed MAX Temp	120°C	
Smart Zone Heating	Inner Circle ø220mm, Outer Ring220-320mm	
Supported Filament	Optimal	PLA, PETG, TPU
	Superior	ABS, ASA, PA, PC, PET
	Ideal	Carbon/Glass Fiber Reinforced PLA
Drying	Separate Heating elements, Desiccant	
Fan	CPAP turbofan	
Speed	Max Speed of Tool Head	1200mm/s
	Max Acceleration of Tool Head	40000mm/s ²
	Max Instantaneous Flow	110/mm ³ (Flsun PLA-HS)
	Stable Flow Rate	60mm ³ /s (Material: Flsun PLA-HS; Temperature: 240°C; nozzle: 0.4mm)

Input	110-240V,50/60HZ
Power	1300W@220V, 600W@110V
Display	Full-Integration Touchscreen
Storage	16GB EMMC,32GB USB Flash
Control Interface	Touchscreen, PC Interface
CPU	Quad-Core ARM A7 1.5 GHz
NPU	2 tops
Pixels	1920 × 1080 pixels
Real-time Monitoring	Support
Time-lapse Photography	Support
Remaining Filament Weight	Dynamic Monitoring
Filament Detection	Support
Filament Clog Detection	Support
Vibration Compensation	Support
Auto-Leveling	Support
Debris Detection	Support
Spaghetti Detection	Support
Screen auto sleep	Support
Printer auto power off	Support
Smart Zone Heating	Support
Power Off Resume Print Module	Support (Z lift, protect model)
Air Filter	Composite filter: HEPA + Activated Carbon
Upgrade Method	OTA
Slicer	Flsun Slicer, Third-Party Slicers
Supported OS	MacOS, Windows
File Format	STL、OBJ、AMF、3MF

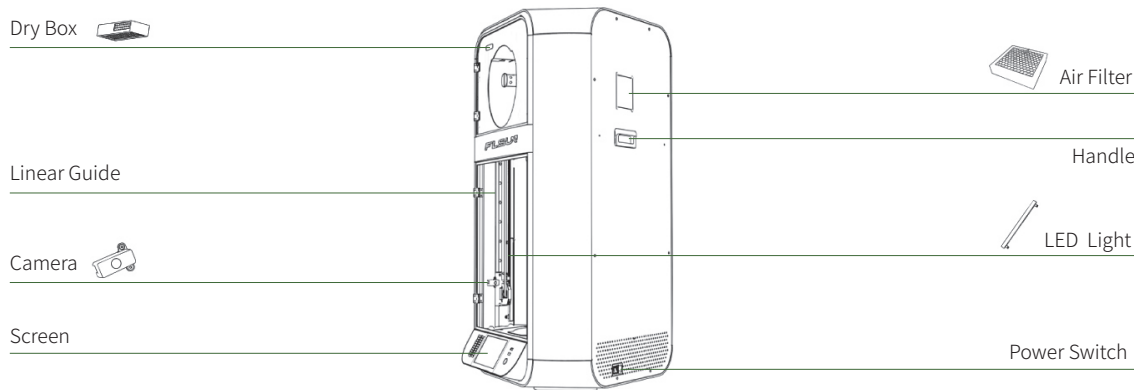
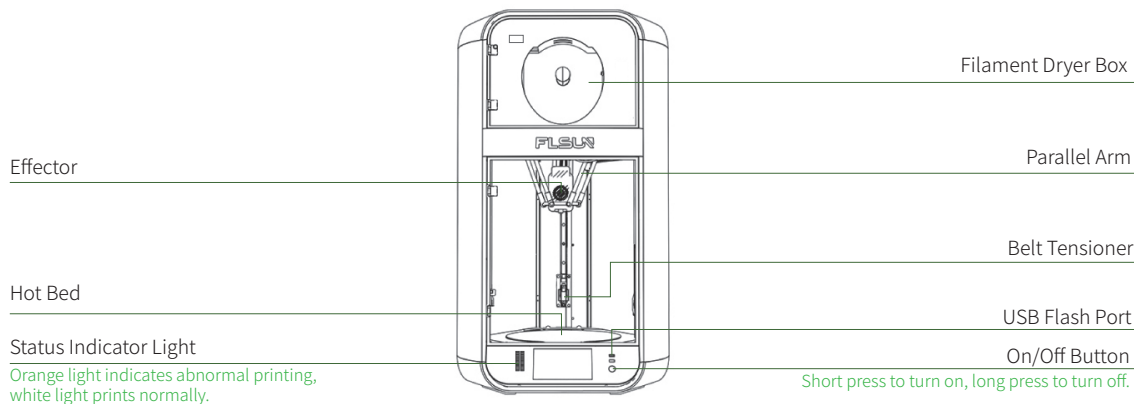

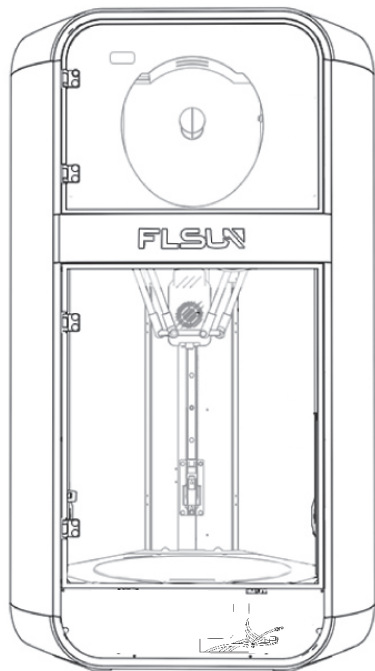

Flsun S1 Pro



Flsun PLA-HS



Screen Module



Service Policy



Power Cord



Accessory Box



Instruction Manual



Door handles (x2)

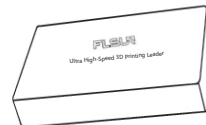

Glass door box



Diagonal Plier



Silver Needle

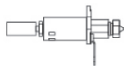

Hotend Kit

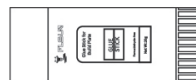

Glue Stick

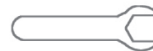

Open-end Wrench



USB Flash



Socket Wrench



Wrench Set



Grease



PTFE Tube

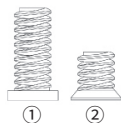

M3*12 (×2) screws
M3*6 (×2) countersunk
head screws
For attaching the screen



Customized screws
with spacers
For attaching glass door

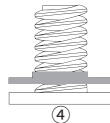

ST2.9*6 (×4) screws
with spacers
For attaching the door handle

1

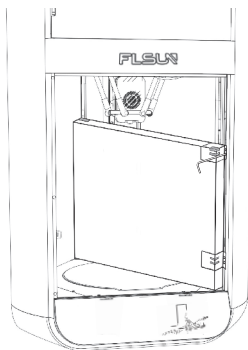

Remove the screws securing the glass door box and remove the box;

2

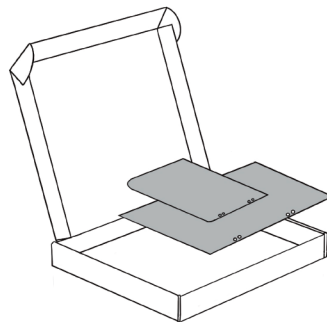

Remove the upper and lower glass doors from the box;

3

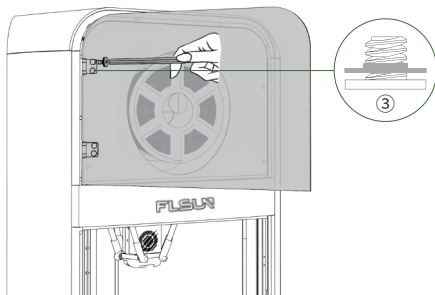

Install the upper glass door with ③ customized screws;

*Gently tighten the screws

4

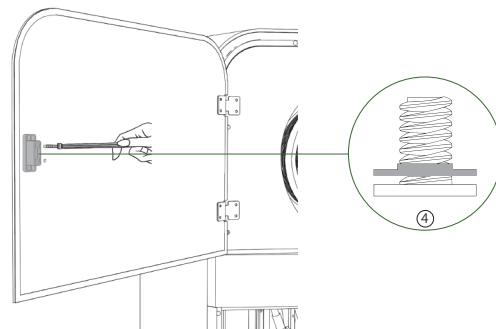

Use ④ST2.9*6 screws to install the upper glass door handle ;

5

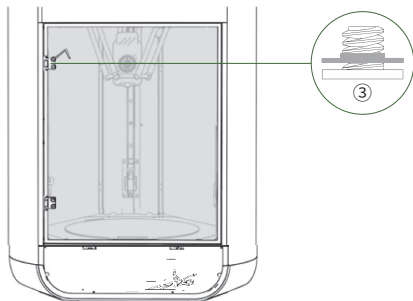

Install the lower glass door using ③ customized screws;

6

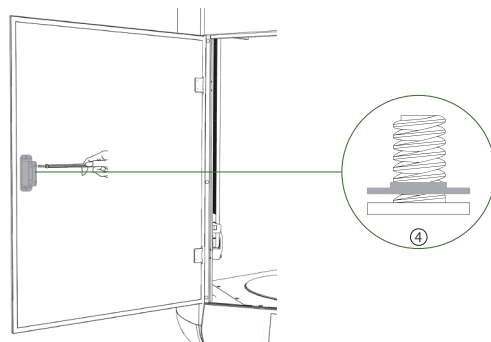

Install the lower glass door handle using the ④ST2.9*6 screws;

7

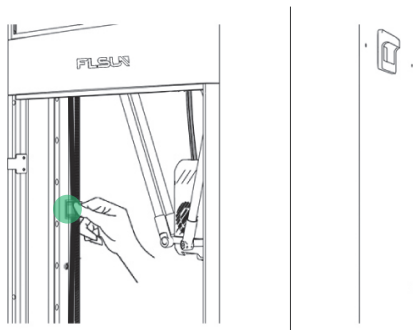

Remove the clips from the three belts to unlock the sliders.

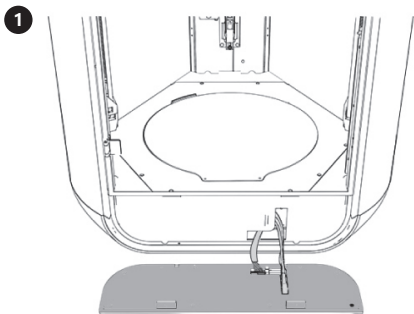

1 Remove the tape holding the cables in place and plug the display power cord and **two data cables** into the corresponding ports;

*The three USB cables are connected by the number.

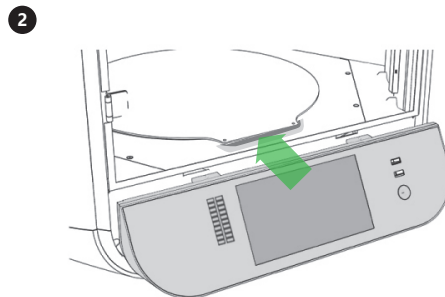

2 Insert the screen horizontally into the printer slot;

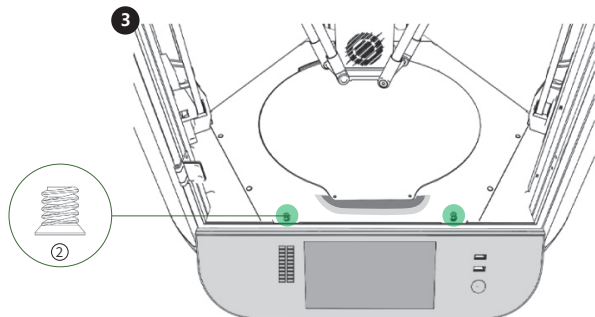

3 Secure the top of the screen using the M3*6 screws included in the accessory box;

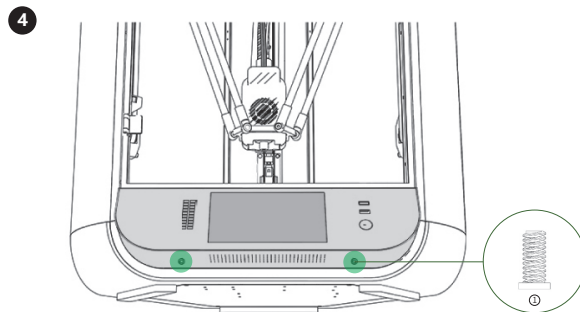

4 Secure the underside of the screen using the M3*12 screws included in the accessory box.

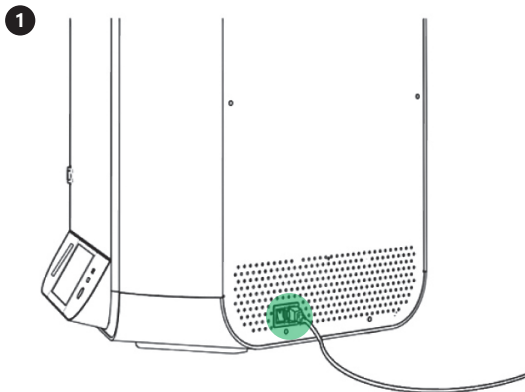

Connect the power cord to the right side of the printer. Press the power switch. The switch will light indicating it is in standby mode;

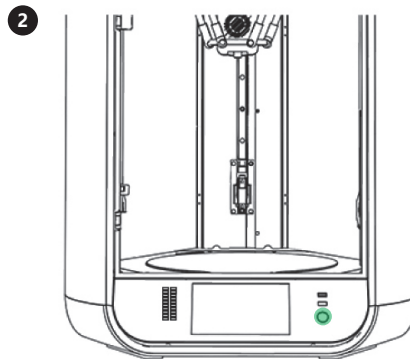

Press the power on/off button to turn on the printer.

*In case of an emergency while the printer is operating, press and hold the on/off button for 1.5 seconds to stop the printer. If you turn off the power first, the printer will activate the UPS, delay power outage, and the printer will continue to run briefly.

Language Settings

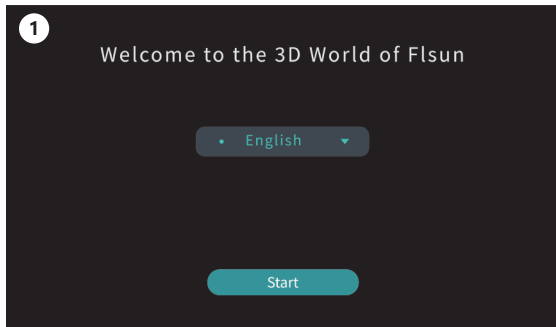

Please click “▼”;



Please select the language and start using the printer;

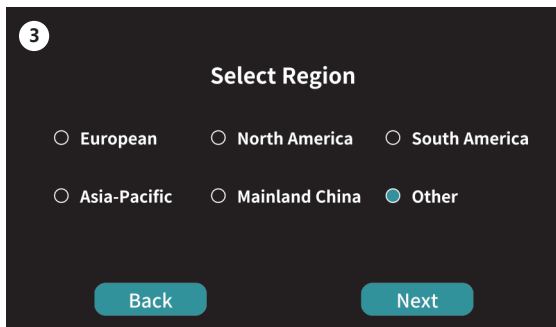

Select the region according to your location and click “Next”;

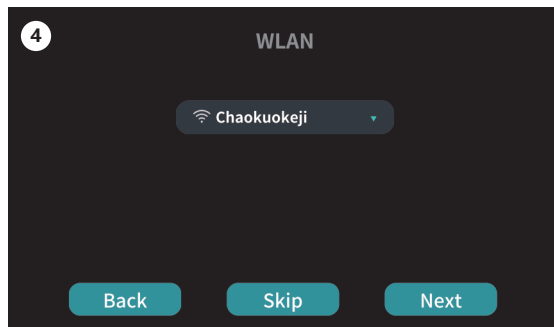

Please click “▼” to select the wireless network,you want to connect to;



Unable to click "Next" during setup of network connection;

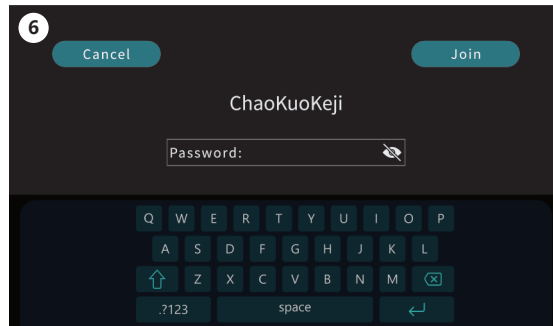

Enter WiFi password;

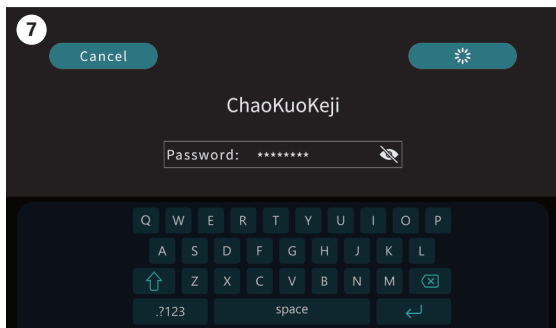

Click "Join" to connect to the network;

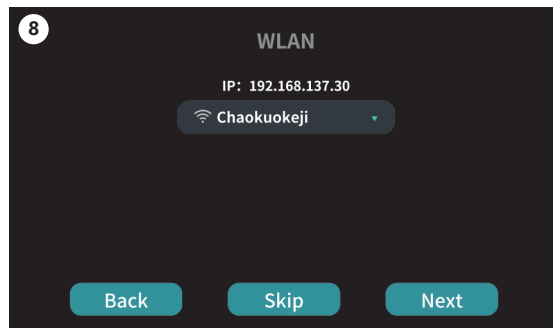

If the IP address appears, the wifi connection is successful, click "Next";

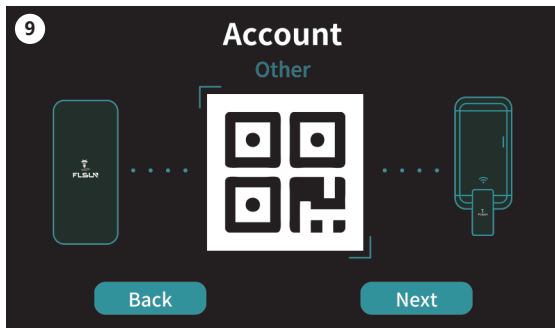

First of all, download Flsun World from APP Store, after the device is successfully networked, follow the prompts and use Flsun APP to scan the code to bind the device in order to realize the remote control from the mobile terminal;

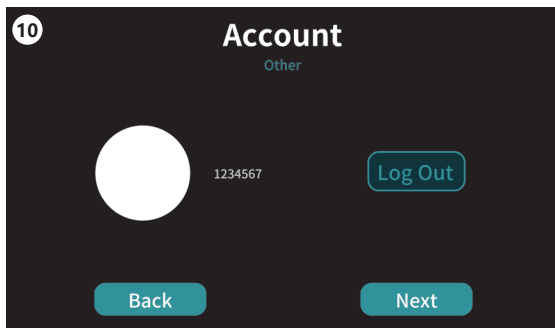

Account Binding Successful, click "Next";

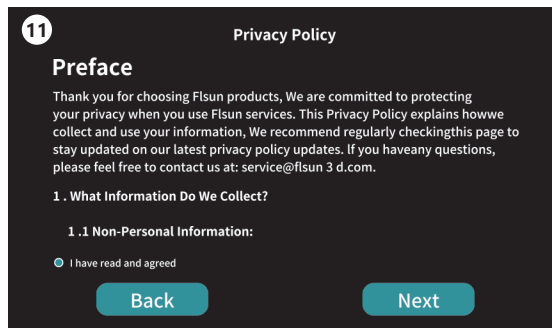

Follow the prompts, check the box to agree to the Privacy Policy, and click "Next".



Access to the main display page;

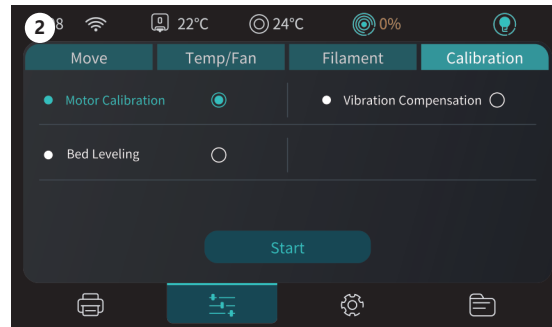

After turning on the machine for the first time, perform "Motor Calibration", "Vibration compensation" and "Bed leveling" in order.

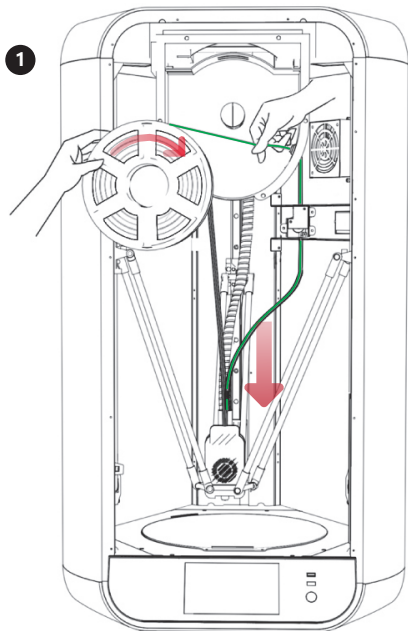

Push one end of the filament into the feed tube on the right side of the filament dryer box, passing through the filament detector and filament clogging detector, and push the filament down into the effector until the filament cannot move forward;

*The filament spool rotation is clockwise.

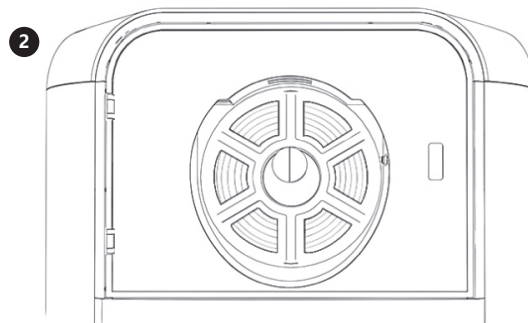

Install the filament into the filament holder;

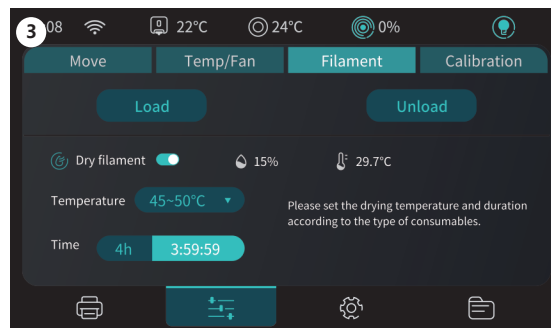

Click on "Filament" - "Load";

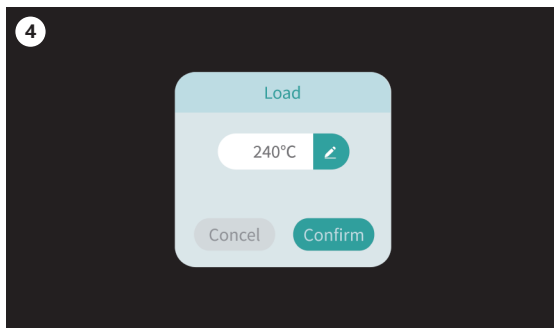

The default load temperature is 240 °C, click "Confirm" to start heating;

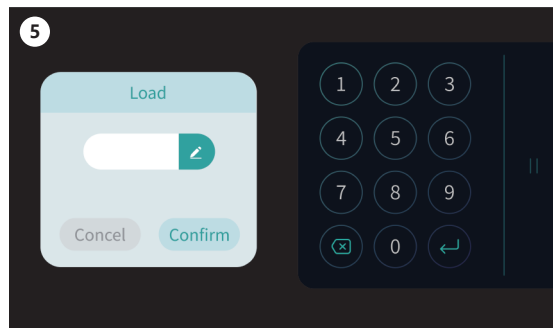

You can click "☒" to manually set the temperature that corresponds to your filament;

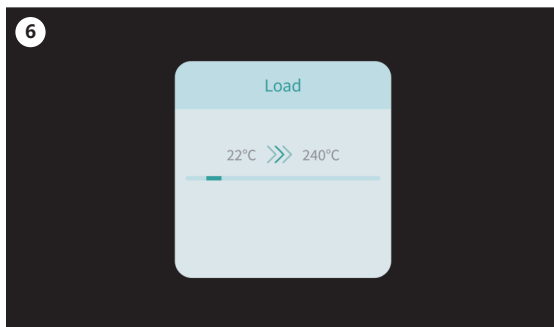

Wait for temperature to rise to 240 °C (or specified temperature);

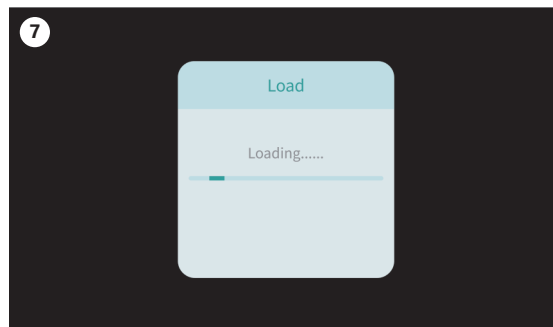

The extruder is loading the filament until the filament is extruded from the nozzle.

1



Apply a layer of glue stick to the PEI sheet;

2

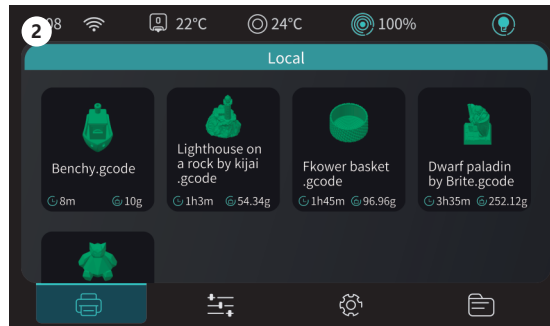

Click on "🖨️" and select the model you want to print;

3

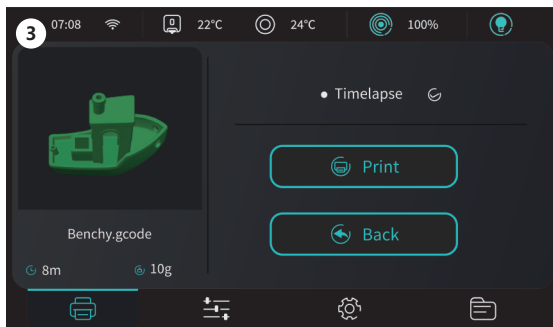

Click "🖨️" to start printing;

*Function can be manually enabled based on your printing requirements.

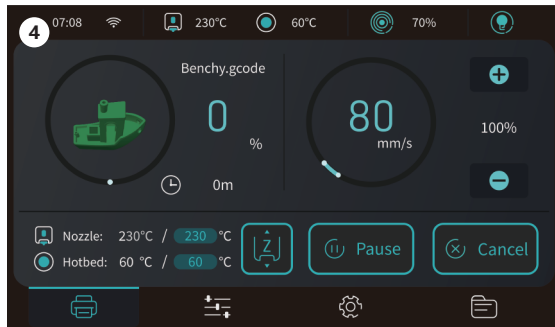

If the nozzle is too low or too high when printing the first layer, you can click "Z" during printing to adjust the height of the nozzle and the adjustment will be automatically saved.

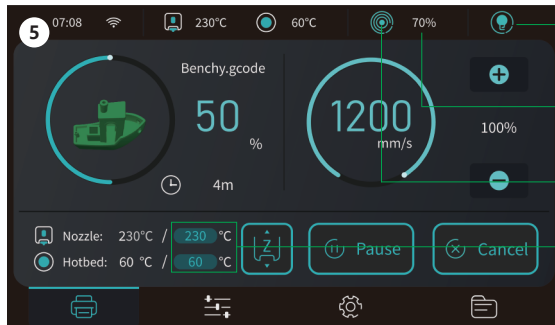
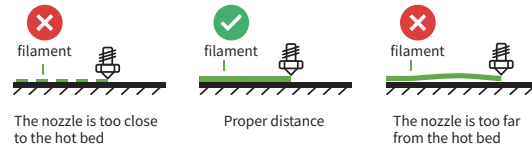

Control the switch of LED lights

Remaining filament weight

Filament drying box status: When it lights up, it means the filament drying box is heating.

The temperature of the nozzle and hot bed can be manually modified during printing.

Please go to flsun official website to download Flsun Slicer :

Official website: <https://flsun3d.com>

Please visit the official Flsun Wiki for more information on machine use, maintenance and FAQs:

<http://wiki.flsun3d.com/en/home>

By scanning the QR code you can choose any channel to get the latest product updates and related news.

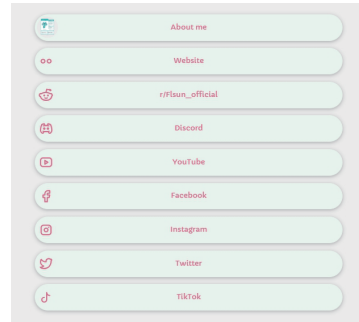

If you need additional assistance, please feel free to contact us:

After-sales e-mail: service@flsun3d.com

Go all the way forward and break through the limitations!

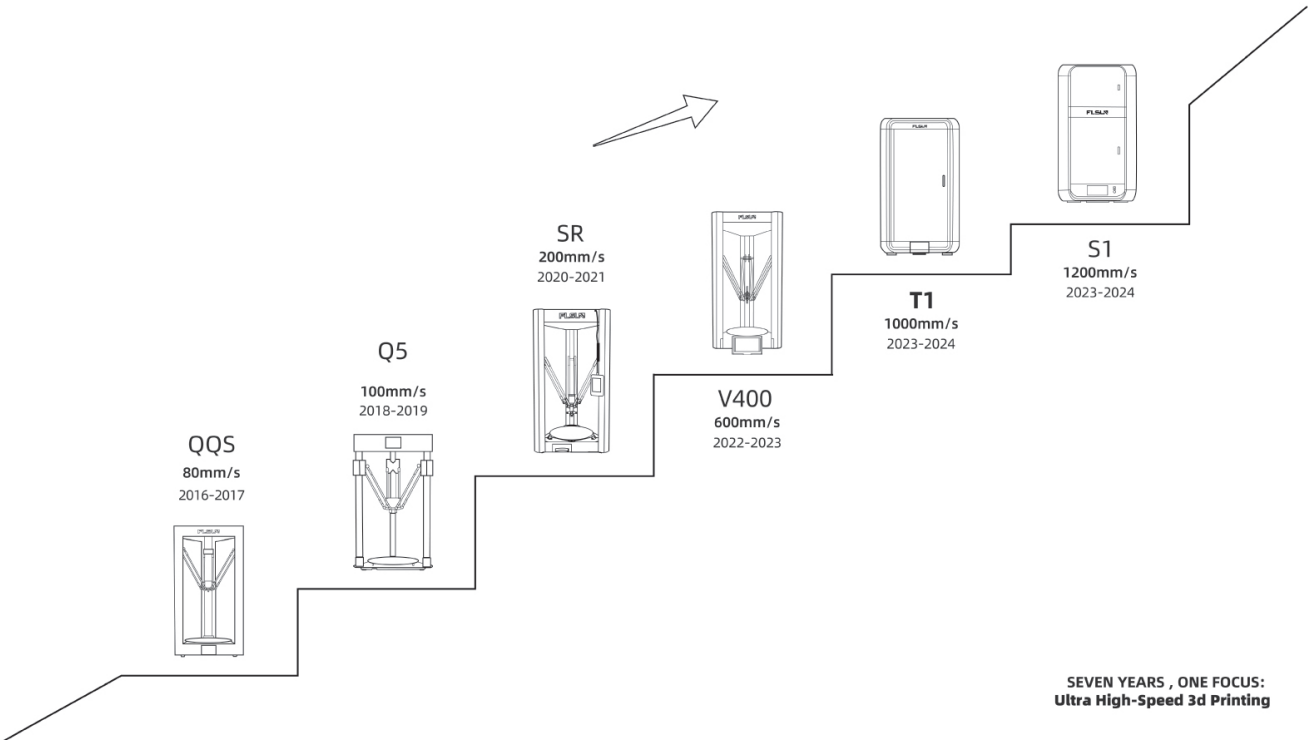

SEVEN YEARS , ONE FOCUS:
Ultra High-Speed 3d Printing



FLSUN

Bring the personalized production capacity to everyone's desktop

www.flsun3d.com