

Cybovac

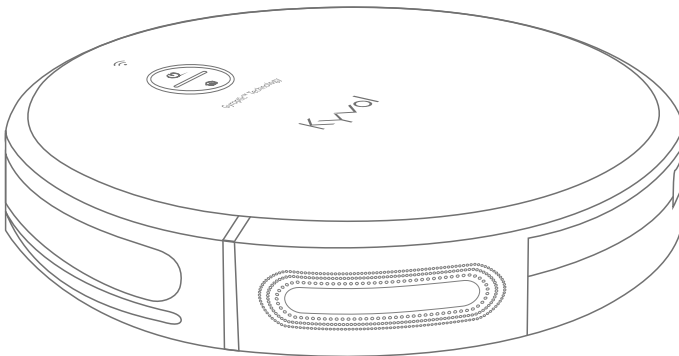

Robot Vacuum Cleaner User Manual

E31

CONTENTS

IMPORTANT SAFETY INSTRUCTIONS	01
BATTERY	02
PACKING LIST	03
PRODUCT OVERVIEW	04
ROBOT VACUUM CLEANER	04
CHARGING BASE	05
REMOTE	05
GETTING STARTED	06
OPERATION GUIDE	08
CLEANING PREPARATION	08
POWER ON/OFF	09
CLEANING MODES	10
Auto Mode	10
Spot Mode	11
Edge Mode	12
AUTO CARPET BOOST	12
MOPPING THE FLOOR	13
TIME SETUP	14

CLEANING SCHEDULE SETUP	15
SLEEP MODE	16
USING THE MAGNETIC STRIP	16
MAINTENANCE AND CARE	18
CLEANING AND REPLACEMENT FREQUENCY	18
DUST BIN AND FILTER	19
SIDE BRUSH	21
MAIN BRUSH	22
SENSORS AND CHARGING CONTACTS	23
ROBOT TOP	24
OMNI-DIRECTIONAL WHEEL	24
WATER TANK AND MOPPING CLOTH	25
SPECIFICATIONS	26
TROUBLESHOOTING GUIDE	27
FREQUENTLY ASKED QUESTIONS	27
A GUIDE TO INDICATORS AND BEEPS	29
Solid Red Indicators	29
Flashing Red Indicators	29

IMPORTANT SAFETY INSTRUCTIONS

READ THESE INSTRUCTIONS BEFORE USING THIS CYBOVAC.

IT IS INTENDED FOR HOUSEHOLD USE ONLY.

- This Cybovac could be used by users aged from 8 years and above, but for the persons with reduced physical, sensory or mental capability, or by people who are lack of related experience and knowledge, only if they have received proper supervision or instructions by a professional who knows how to use the appliance in a safe way and understand the hazards involved.
- DO NOT let children or your pet play with the appliance. Do not allow them to sit or stand on the appliance either.
- DO NOT use the accessories or replacement parts from unauthorized channels. Only use the **ORIGINAL** parts provided by KYVOL. Please directly contact us whenever they are needed.
- DO NOT operate the appliance on the wet surfaces, or in a bathroom, or near a pool. Additionally, do not spill any water on the appliance, or expose it to any moisture, rain or snow.
- DO NOT let the appliance to clean a room where an infant or child is unattended.
- DO NOT utilize the appliance to pick up anything that is burning or smoking, such as cigarettes, matches, or hot ashes, etc., to avoid catching fire.
- DO NOT place anything on the appliance or hit against the appliance.
- DO NOT handle any part of the appliance with wet hands.
- DO NOT operate the appliance on waxed floor, which may result in the damage to the appliance or the floor. It's recommended to use the appliance on any hard or carpeted floors.
- NEVER use the power cable or plug that partly damaged.
- DO NOT allow this appliance to clean anything wet, like paint, chemicals, etc..
- DO NOT utilize the appliance to clean flammable or combustible liquids, such as petrol, or use it in areas where there exists vapor.
- DO NOT apply any fragrance or scented products to the filter of this appliance because the chemicals in such items are flammable which may lead to fire.
- DO NOT operate the appliance in the room where there are open fireplaces, lit candles or fragile objects on the floor or where there are candles on candlesticks, tables, etc., which may accidentally hit or bump into, thus leading to fire or causing damage to the appliance.
- DO NOT operate this appliance in areas where exist exposed electrical outlets on the floor.

- This appliance is designed to be used on floors without scratching them. Before cleaning your whole house, it's advised to perform a pre-test on your floor to ensure that no scratches are made.
- Ensure that everyone in the room is aware of the appliance when cleaning to avoid stepping on it or the tripping hazard.
- Make sure the **Dust Bin** or the **Filter** are in place before using this appliance.
- Remove all power cords and other items that could get tangled in the appliance from the area to be cleaned before use.
- Before cleaning, please pick up some objects like loose clothing or paper due to the limited size of the openings. Otherwise, the openings may be blocked.
- Keep the appliance free of lint, hair, and anything that may reduce airflow.
- Please use two hands to carry the appliance to move it.
- Clean the appliance with a dry or damp cloth.
- The **Power Adapter** of **Charging Base** must be removed from the socket before cleaning or maintaining.
- Cleaning and maintenance shall not be done by the children without any adult supervision.
- Unplug the **Charging Base** when not in use for extended periods.
- We assume no liability or responsibility for any fire, explosion or electrical shock caused by improper operation.

BATTERY

- A rechargeable Li-ion battery is installed in the robot.
- DO NOT attempt to disassemble or replace the battery in the robot by yourself as the incorrect operation might cause overheating, fire or injury.
- DO NOT expose the battery pack inside of the appliance to any fire, heat source, direct sunlight or high temperature, which may result in the risk of explosion.
- DO NOT dispose of this appliance or the battery pack in fire, any water or other liquids to avoid the risk of explosion.
- The Li-ion battery in the robot should be serviced or recycled by an authorized service provider, and must be recycled or disposed of separately from household waste. Dispose of the battery according to your local environmental laws and regulations.

PACKING LIST

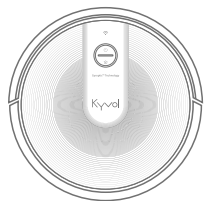

Robot Vacuum Cleaner E31
(Dust Bin Included)

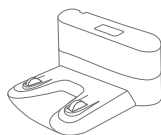

Charging Base



Remote and
AAA Batteries



Cleaning Brush

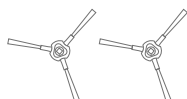

Side Brush x 2



Water Tank (with
Washable Mopping Cloth)



Spare Washable
Mopping Cloth

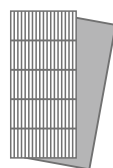

Spare HEPA
and Sponge

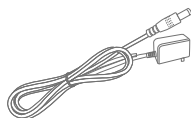

Power Adapter
(for Charging Base)

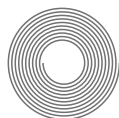

Magnetic Strip
(6.6ft/2m)



3M Adhesive Pads

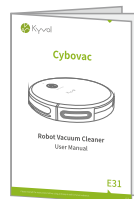

User Manual



User Guide for KYVOL App



Quick Start

PRODUCT OVERVIEW

ROBOT VACUUM CLEANER

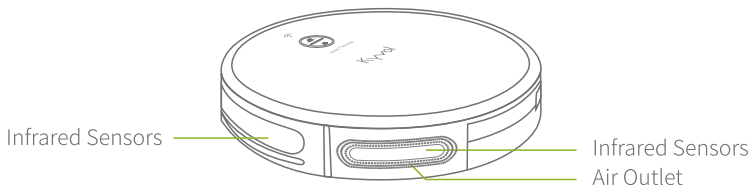
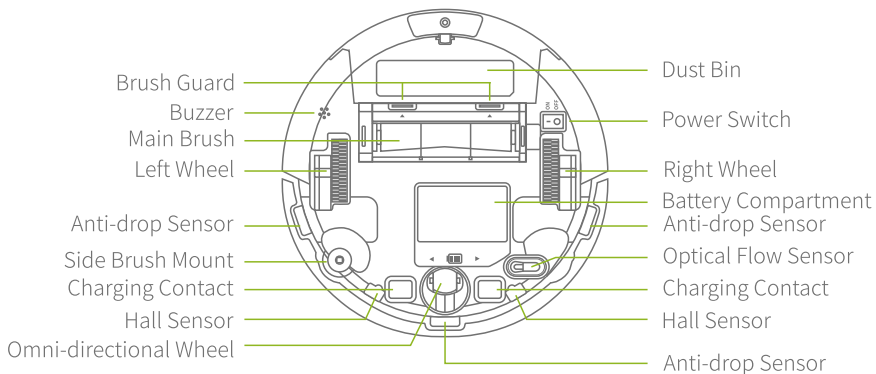
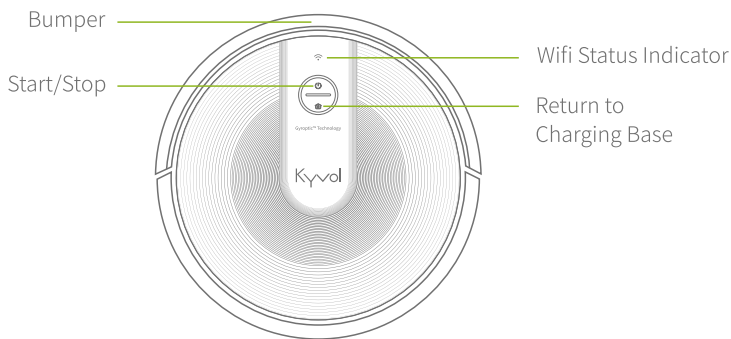

CHARGING BASE

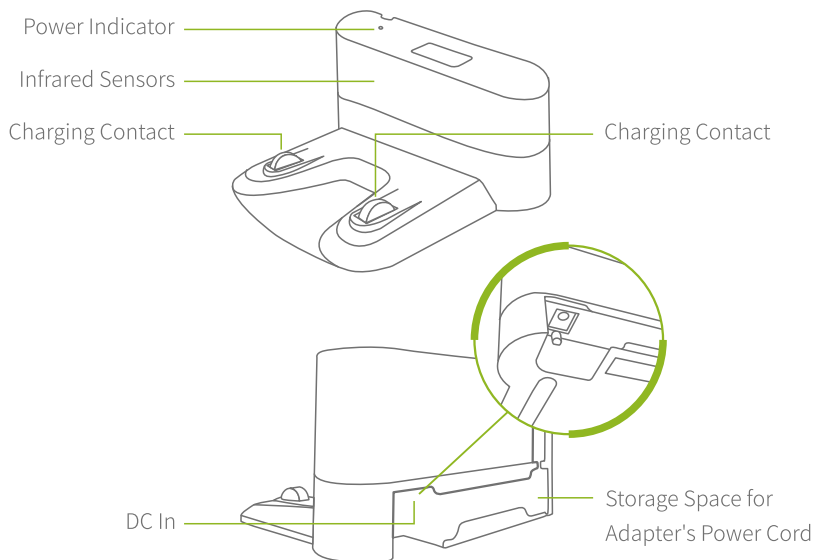

REMOTE

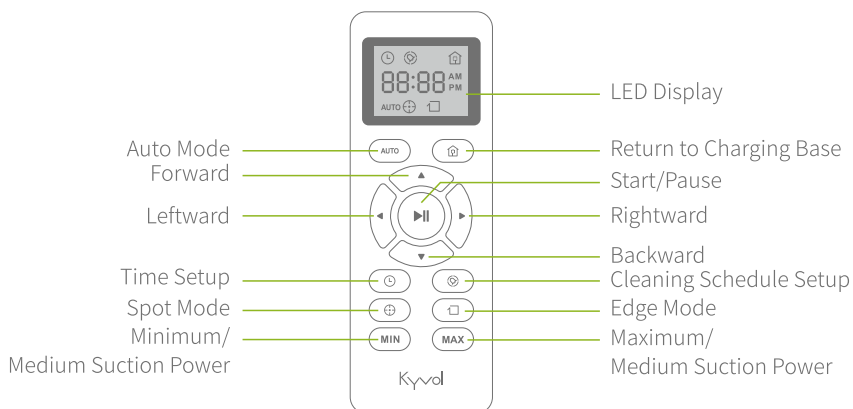

GETTING STARTED

Peel off the sticker that reminds you of discovering the Power Switch.



Remove the protection material from both sides of the robot.



Attach the Side Brush into the Side Brush Mount on the bottom of the robot.

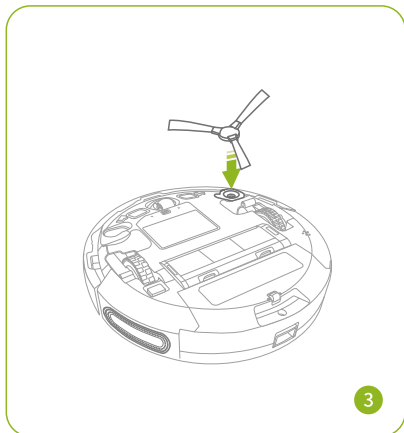

Install the AAA batteries into the Remote.

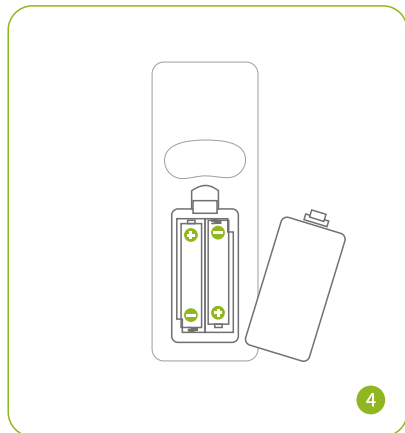

Place the **Charging Base** on a flat surface against the wall, then connect the **Power Adapter** into the base and a socket at room. Remove all the objects within approximately a 1-2m radius of the base.

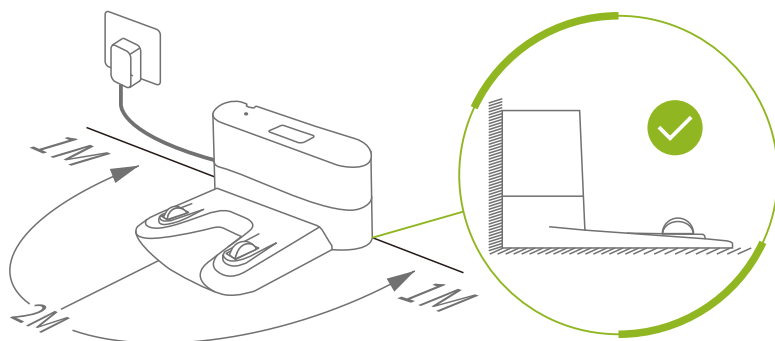

! Notes:

1. Ensure the base is powered, which is indicated by a solid white **Power Indicator** on it.
2. Place the charging base where the robot can easily access.
3. Always keep the **Charging Base** connecting to power to avoid that the robot can't find the **Charging Base** when its battery gets low.
4. It's recommended to tidy any surplus power cord into the **Storage Space** on the back of the base, which may help robot reduce the possibility of getting stuck.

5

Please fully charge your robot before your first use. Manually align the **Charging Contacts** on the bottom of the robot with those on the **Charging Base**.

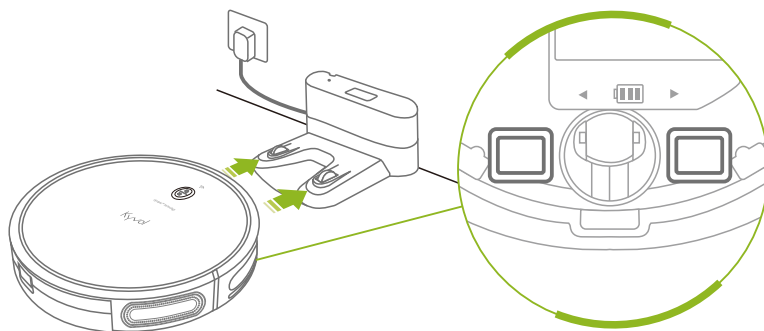

6

Charging:



Pulse orange

Fully Charged:



Solid blue

Low Battery:



Solid orange

Critical Low Battery:



Flash red

! Notes:

1. It takes 6-6.5 hours to reach a full charge, which could last to clean for around 150 minutes with **Auto Mode** and the minimum suction power.
2. The robot will find and return to the **Charging Base** when the battery gets low; while it will not move when the battery gets critical low, please manually get it to charge.
3. To extend the battery's lifespan, please recharge the robot at least once every 3 months if not using for long time.
4. Do not open the battery compartment and replace the battery by yourself. If the robot won't charge, please contact us at support@kyvol.com for further assistance.

7

OPERATION GUIDE

CLEANING PREPARATION

Check and tidy the area to be cleaned to ensure a worry-free operation.

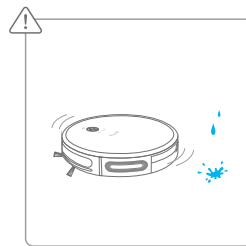
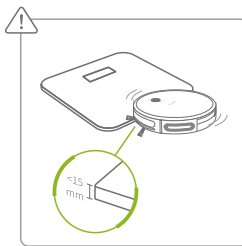
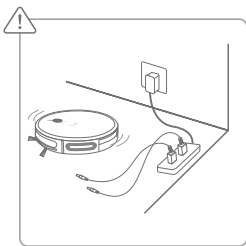

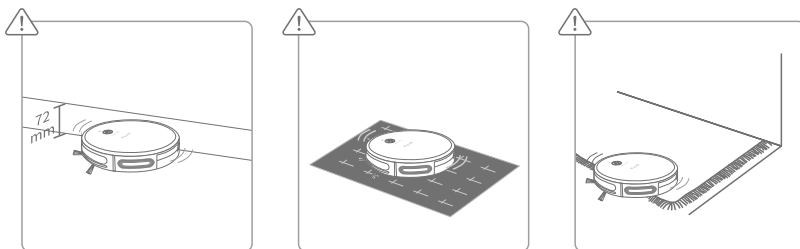

! Notes:

1. Remove any object that may entangle the robot, such as power cords, ropes, etc.
2. The robot can climb to the top of objects with a thickness less than 15mm. Please take the objects away if you do not want the robot to climb them.
3. Do not operate the robot on the wet floor.
4. Keep the robot away from any furniture that may have the space $\leq 72\text{mm}$ (because the thickness of the robot is 72mm) on the bottom. The robot may get stuck if it goes in by accidently. The **Magnetic Strip** could be used in this situation.
5. The robot may not run on certain dark or black colored surfaces since the **Anti-drop Sensors** that recognize an edge or a stair may regard this color as an edge, then the robot will not clean over it.
6. Fold the tasseled edges underneath the area rugs to prevent tangling the robot.

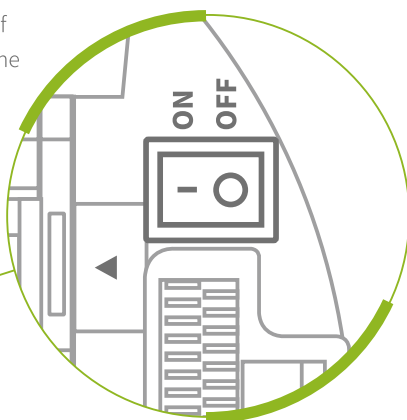
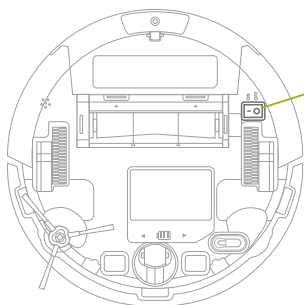

POWER ON/OFF

Press the Power Switch to ON on the bottom of the robot to power it on; to power it off, press the Power Switch to OFF.









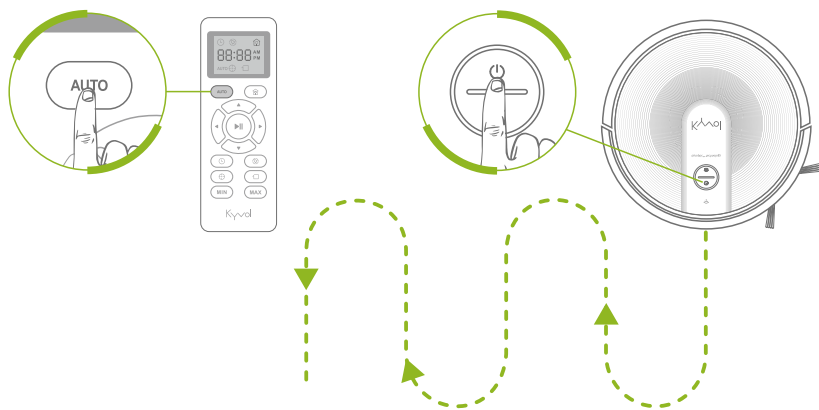



CLEANING MODES

Auto Mode

After powering on, press  on the robot or  on the remote to initiate **Auto Mode** process, in which the robot will clean all accessible space with medium suction power (this is the default level) until the battery gets low.



- * Press  on the robot or  on the remote to pause the cleaning process; press again to resume.
- * Press  on the robot or  on the remote to pause the cleaning process, then press  on the remote to manually adjust the direction of the robot.
- * Press  on the robot or the remote to get it back to the **Charging Base**.
- * Press  /  on the remote to adjust the levels of the suction power. Press  for the medium level; press it again to get back to the minimum level. Press  for the maximum level; press it again to get back to the medium level.

Tips:

- 1 When the battery gets low, the robot will return to the **Charging Base** to make a self-charging. We recommend to fully charge the robot, then operate it as needed. If no cleaning plans, please let the robot always connect with the **Charging Base**.
- 2 If you set a schedule for **Auto Mode**, the robot will beep to respond to the schedule even in low-battery status, but can't perform the cleaning due to the low battery.
- 3 If the robot is not managed to find the **Charging Base** due to obstacles or getting stuck, please manually get it to contact with the **Charging Base**.

Spot Mode

This cleaning mode aims to intensively clean a specific area.

Step 1:



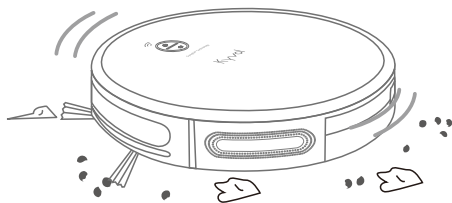



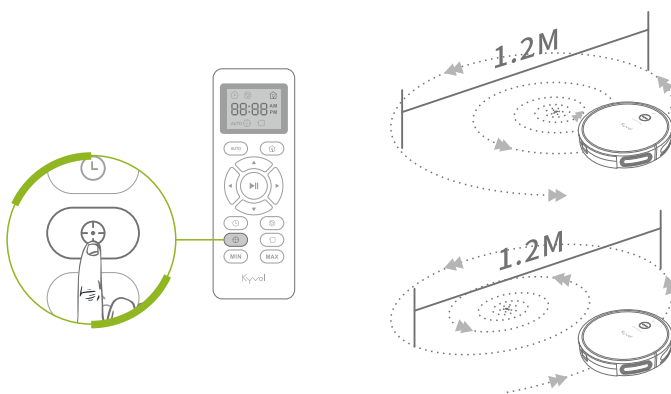

Locate any area where needs to be cleaned intensively, namely there exist much debris or dust, then move the robot to the center of the area.



Step 2:

Press  to initiate the spot cleaning process in a spiral pattern. The maximum diameter of the spiral circle is around 1.2 meter (3.9ft). The process will last around 2 minutes, then the robot will go into **standby mode** if no any operation is resumed.



- * Press  on the robot or  on the remote to pause the current cleaning process; press again to switch to **Auto Mode**. If you'd like to resume spot mode, press  on the robot or  on the remote to pause the auto mode, then press  again.
- * Press  on the robot or  on the remote to pause the cleaning process, then press  on the remote to manually adjust the direction of the robot.
- * Press  on the robot or the remote to get it back to the **Charging Base**.

Tips:







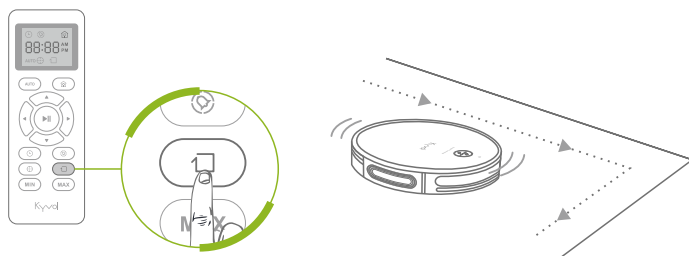

- 1 When the battery gets low, the robot will return to the **Charging Base** to make a self-charging. We recommend to fully charge the robot, then operate it as needed. If no cleaning plans, please let the robot always connect with the **Charging Base**.
- 2 If the robot is not managed to find the **Charging Base** due to obstacles or getting stuck, please manually get it to contact with the **Charging Base**.

Edge Mode

This mode is to thoroughly clean the edges along the wall or any furniture.

Press  on the remote to initiate the edge cleaning process. The robot will clean for around 20 minutes along the edges, then return to the **Charging Base**.



- * Press  on the robot or  on the remote to pause the cleaning process; press again to switch to **Auto Mode**. If you'd like to resume edge mode, press  on the robot or  on the remote to pause the auto mode, then press  again.
- * Press  on the robot or  on the remote to pause the cleaning process, then press  on the remote to manually adjust the direction of the robot.
- * Press  on the robot or the remote to get the robot back to the **Charging Base**.

Tips:

- 1 When the battery gets low, the robot will return to the **Charging Base** to make a self-charging. We recommend to fully charge the robot, then operate it as needed. If no cleaning plans, please let the robot always connect with the **Charging Base**.
- 2 If the robot is not managed to find the **Charging Base** due to obstacles or getting stuck, please manually get it to contact with the **Charging Base**.

AUTO CARPET BOOST

The robot automatically increases the suction power on carpet to provide a deeper clean. When on a hard surface, the robot will return to the medium suction power to provide just the right amount of power without wasting its battery.

Tip:

If the level of the suction power is the maximum level before cleaning on a carpet, the robot will continue cleaning the carpet with the maximum power after moving on the carpet.

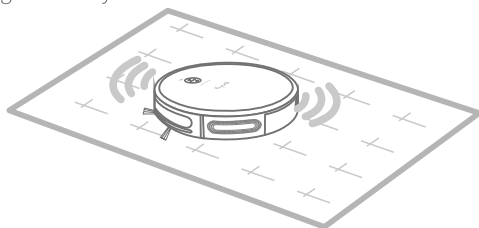

MOPPING THE FLOOR

Step 1:

Fill the Water Tank with water.

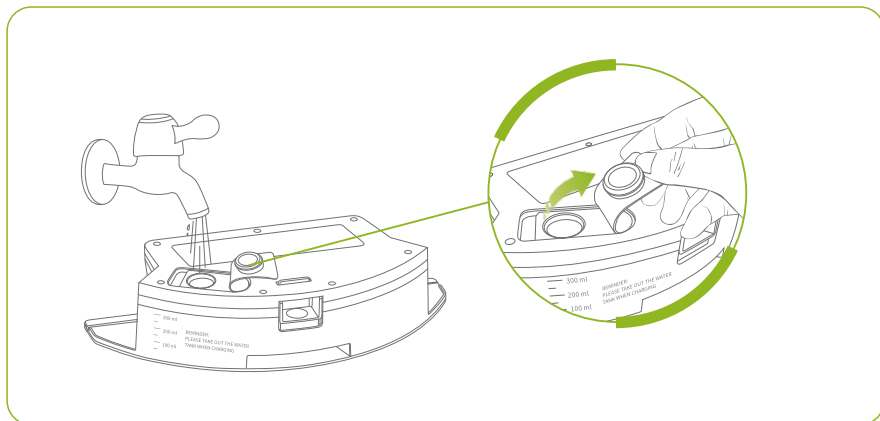

Step 2:

Press and hold the latch down to pull the Dust Bin out.

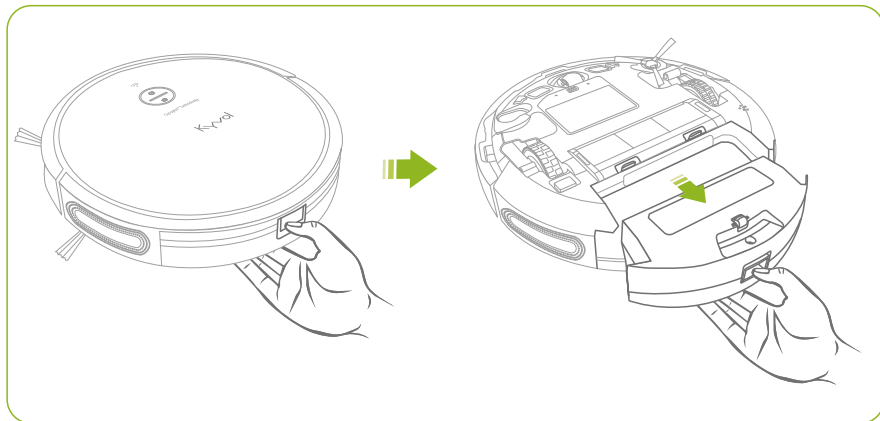

Step 3:

Press and hold the latch down and insert the **Water Tank** into the robot.

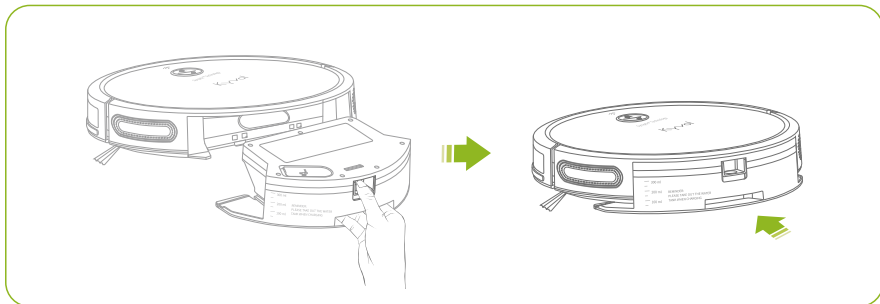
**Step 4:**

Select a cleaning mode to start mopping the floor.



Tip:

Go to **Kyvol App** to adjust the water volume for mopping.

Notes:

1. Take out the **Water Tank** when the robot is charging or not in use.
2. Only use water in the **Water Tank**. Do not use any cleaning solution, even natural ones, which will cause damage to the robot.
3. Do not mop the carpeted floor.
4. The robot cleans best on smooth hard surfaces and may not perform as well on uneven or rough surfaces.
5. Do not leave the robot unattended when using it to mop the floor.

TIME SETUP

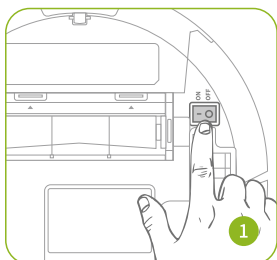

You can set the time in 12-hour clock format.

Power on the robot by pressing the **Power Switch** to ON.

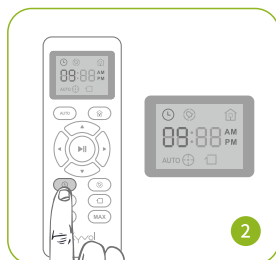

Press  on the remote and the **HOUR** will flash on the LED Display.



Press   to adjust the value of **HOUR**.



Press **▶** to move to the option of **MINUTE**.

Press **▲▼** to adjust the value of **MINUTE**.

Press **⏻** or **▶▶** to save the time you set. A beep from the robot indicates the successful setting.

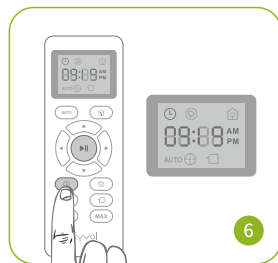
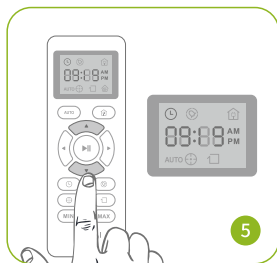
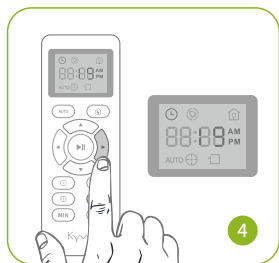

Tip:

Make sure the remote and the robot are as close as possible when setting the time.

CLEANING SCHEDULE SETUP

Important:

Make sure you've set up the time according to your local time before setting a cleaning schedule.

The function of setting cleaning schedules is only available for **Auto Mode**. After setup, your robot will start cleaning at the scheduled time.

Power on the robot by pressing the **Power Switch** to **ON**.

Press **⏻** on the remote to start setting a schedule, the **HOUR** will flash on the LED Display.

Press **▲▼** to adjust the value of **HOUR**.

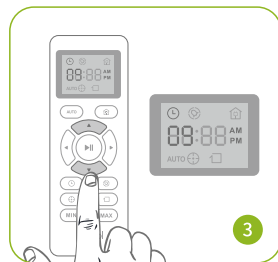
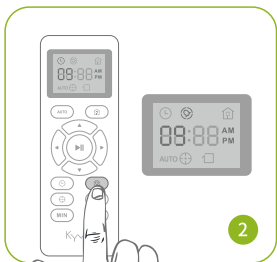
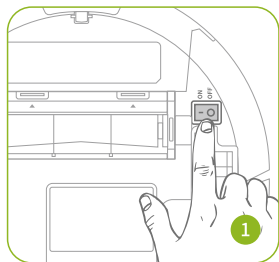

Press **▶** to move to the option of **MINUTE**.

Press **▲▼** to adjust the value of **MINUTE**.

Press **⏻** or **▶▶** to save the setting. A beep from the robot indicates the successful setting.

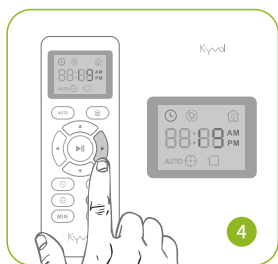

☀ Tips:

- 1 Make sure the option of **AM/PM** is set correctly.
- 2 You can only select from options of **15, 30, 45** and **00** when setting **MINUTE**.
- 3 Make sure the remote and the robot are as close as possible when setting the schedule.
- 4 Only one schedule can be set when using the remote, and the schedule can be cancelled permanently by long pressing **⏻** on the remote. Two beeps from the robot indicate the successful setting.

SLEEP MODE

To reduce battery consumption, the robot will go into the **Sleep Mode** when it is idle for 5 minute; press **⏻** on the robot or any button on the remote to wake it up. Then you can press the corresponding button to operate the robot to clean as needed.

USING THE MAGNETIC STRIP

Magnetic Strip aims to set no-go areas such as pet food bowls or beds, as well as to prevent entering rooms if desired.

Step 1:

Verify the area you do not want the robot to access.

Step 2:

Correctly measure the length and width of the area, then cut the strip to a proper length.



Step 3:

Peel off a piece of 3M Adhesive Pad, then affix it to one side of the Magnetic Strip; so do the other 3M Adhesive Pads.

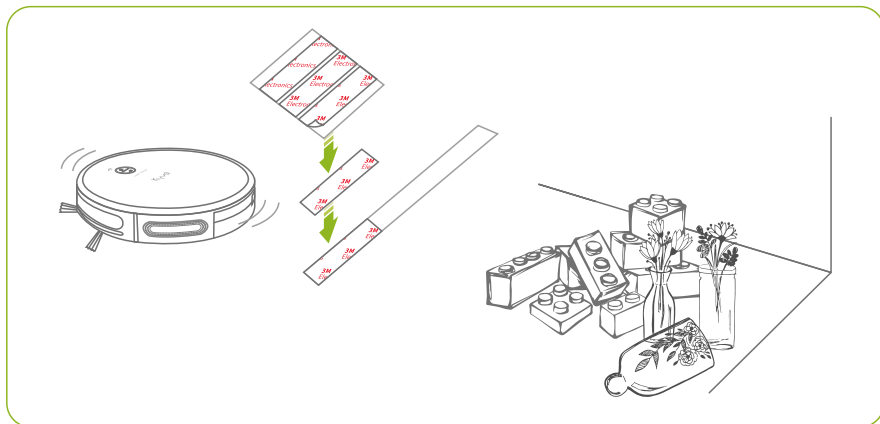

Tip:

The number of the Adhesive Pads varies depending on the strip length.

Step 4:

Peel off the other side of the 3M Adhesive Pads, then utilize them to affix the Magnetic Strip on the floor to make a barrier.

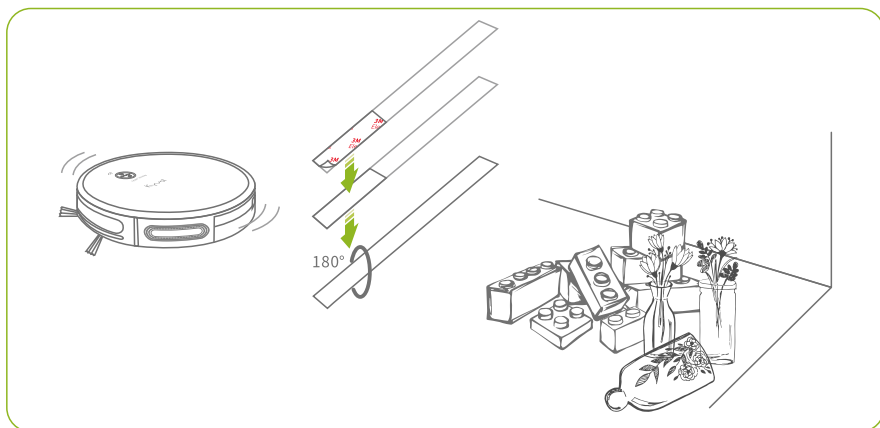

Tips:

- 1 If the strip is rolled up, please remove and affix it again on the floor; otherwise, it may not work effectively. It's not recommended to use strip on the carpet.
- 2 Make sure the strip is affixed on the same surface level as the robot's.
- 3 Keep the strip away from anything that can emit excessive heat.

MAINTENANCE AND CARE

To optimize the performance of your robot, we recommend to perform a regular maintenance and cleaning for some parts in the robot.

CLEANING AND REPLACEMENT FREQUENCY

Part	Cleaning Frequency	Replacement Frequency
Dust Bin	After each use	/
Filter	Once per week (Twice per week if you have pets)	Every 2 months
Side Brush	Once per week	Every 3-6 months or when it's visibly worn
Main Brush	Once every 2 weeks	Every 6-12 months or when it's visibly worn
Brush Guard	Once per month	/
Sensors	Once per month	/
Charging Contacts	Once per month	/
Omni-directional Wheel	Once per month	/
Water Tank	After each use	/
Mopping Cloth	After each use	When it's visibly worn

DUST BIN AND FILTER

Please empty the **Dust Bin** after each use and clean the **Filter** regularly.

Step 1:

Press and hold the latch down to pull the **Dust Bin** out.

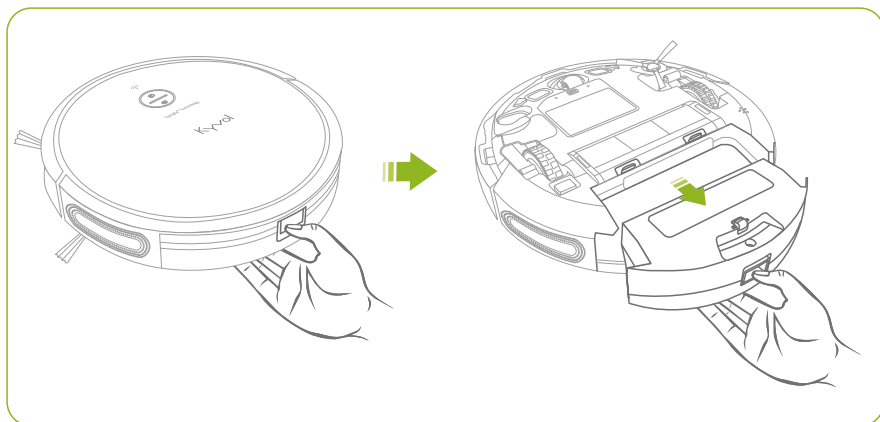

Step 2:

Open the upper cover of the **Dust Bin** to empty the dust into a trash bin.

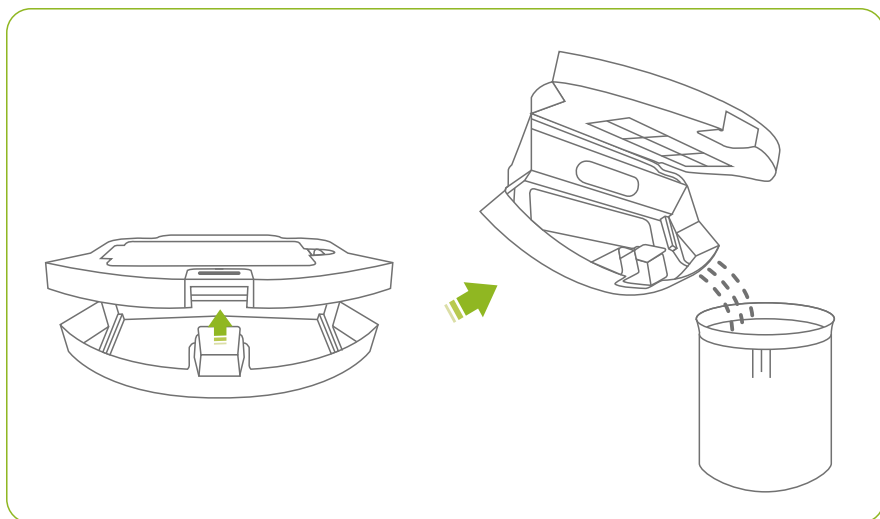

Step 3:

Close the Dust Bin, then open the Filter Compartment.

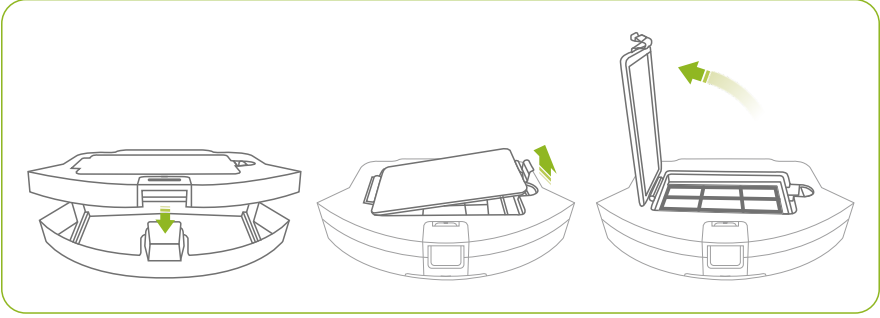

Step 4:

Take the Filter out, then tap the dust into a trash bin.

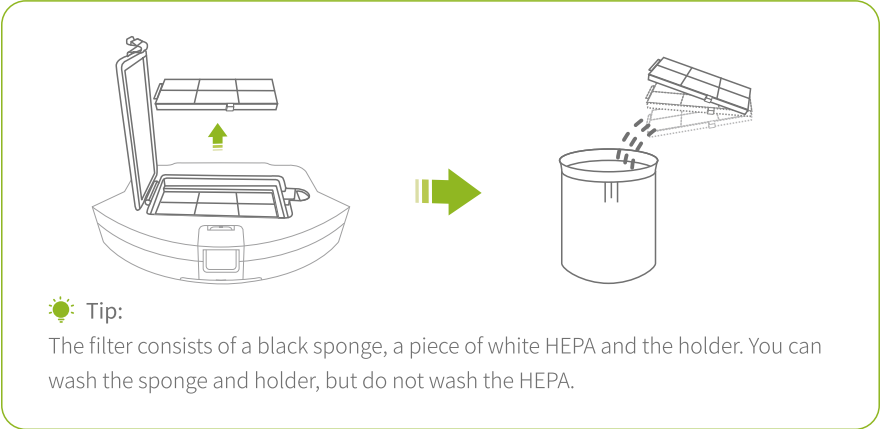

 Tip:

The filter consists of a black sponge, a piece of white HEPA and the holder. You can wash the sponge and holder, but do not wash the HEPA.

Step 5:

Place the Filter into the compartment, then insert the Dust Bin into the robot.

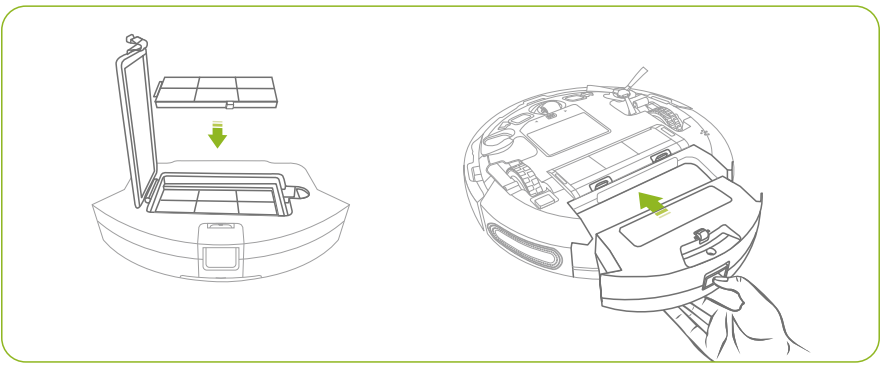

Tips:

- 1 The **Filter** can effectively filter the dust to prevent the dust from entering the inside of the robot, which can help protect the ventilation system of the robot and avoid the secondary air pollution.
- 2 The **Cleaning Brush** () can be used to clean the filter as well.

SIDE BRUSH

Regularly cleaning or replacing the **Side Brush** is recommended since they may become bent or damaged after a period of use.

Step 1:

Pull out the side brush.

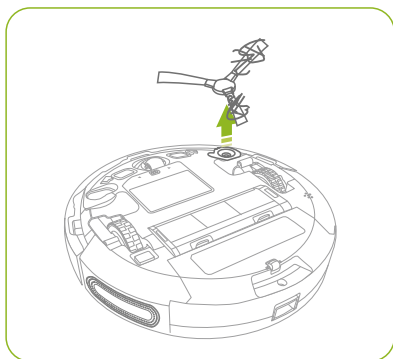

Step 2:

Utilize the blade of the **Cleaning Brush** to remove the hair or debris that is wrapping the brush.

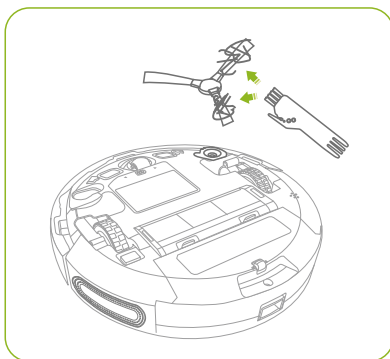

Step 3:

Clean them with a damp cloth.

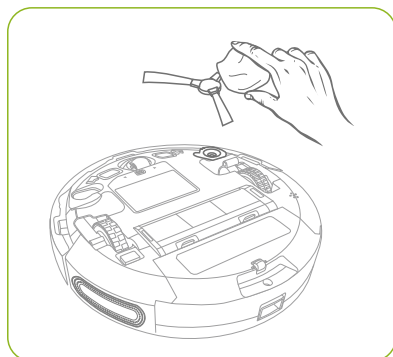

Step 4:

Snap the side brush into place. If the old brush is damaged, you can directly install the new brush.

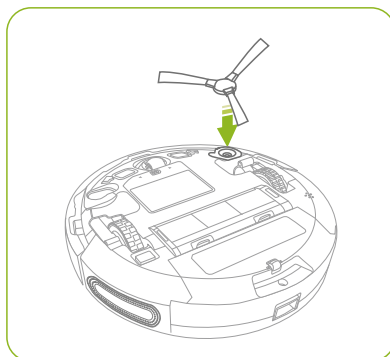

MAIN BRUSH

Step 1:

Turn over your robot to find the Main Brush.

Step 2:

Simultaneously push the latches to remove the Brush Guard over the brush.

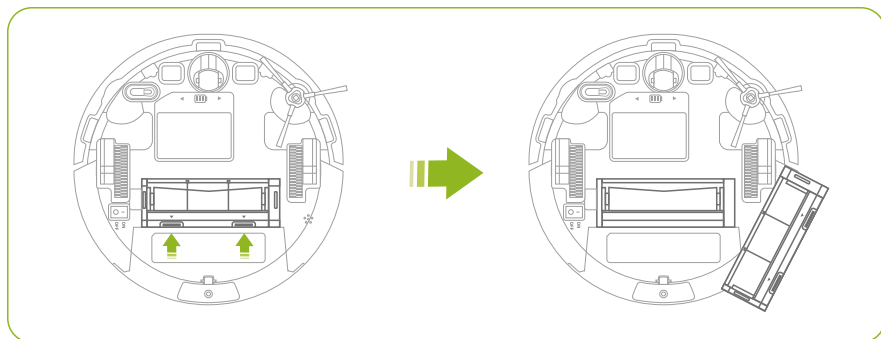

Step 3:

Use the blade of the Cleaning Brush to cut the hair, and use the brush of it to remove the dirt.

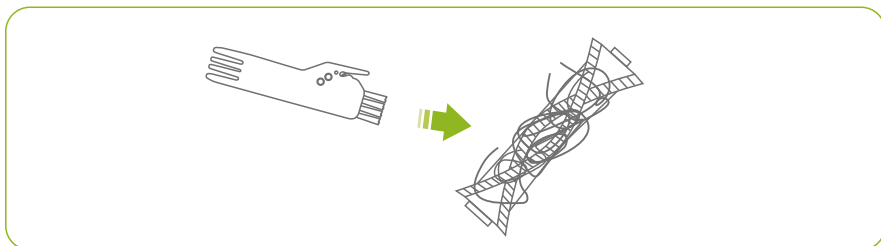

Step 4:

Insert the Main Brush, then install the Brush Guard.

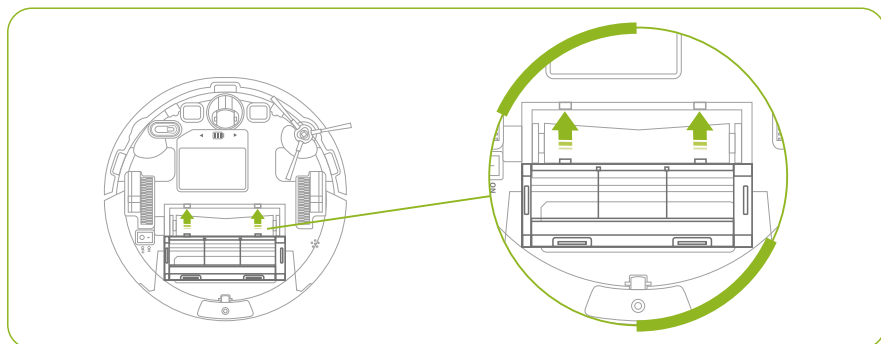

SENSORS AND CHARGING CONTACTS

- 1 Use a damp cloth to clean all sensors on the robot and the Charging Base.

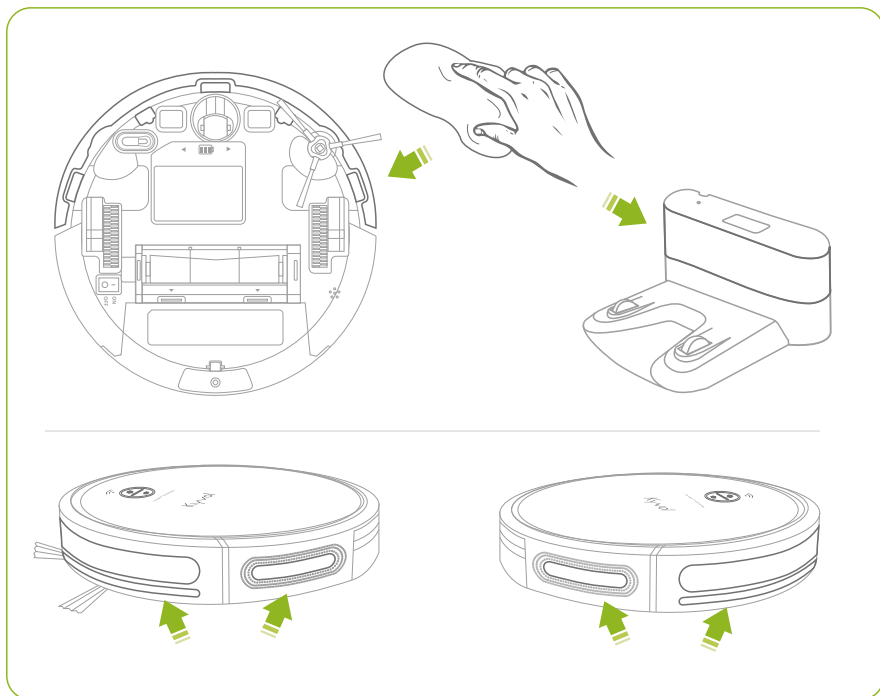

- 2 Use a dry cloth to clean the Charging Contacts on the robot and Charging Base (alcohol is not recommended).

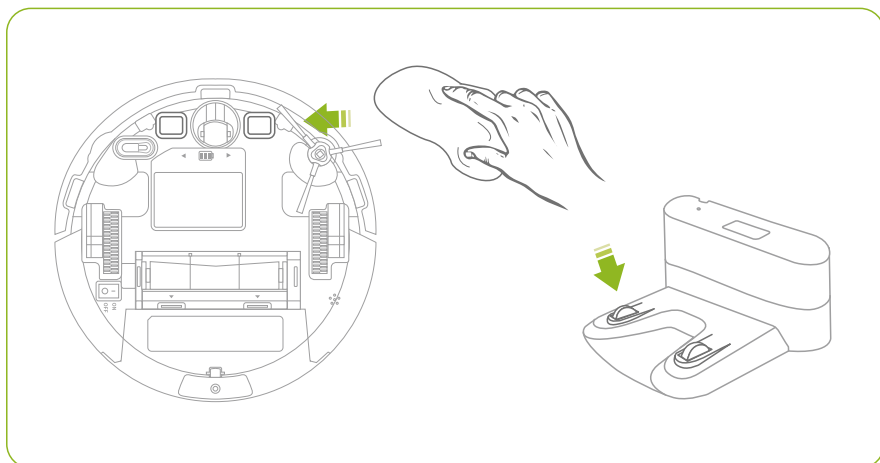

ROBOT TOP

Clean the top of the robot with a damp cloth.

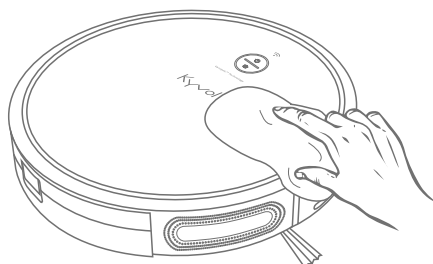

OMNI-DIRECTIONAL WHEEL

The **Omni-directional Wheel** can't be pulled out, please remove any hair or debris that is wrapping the wheel or entangled inside the wheel cavity with the **Cleaning Brush** we provided.

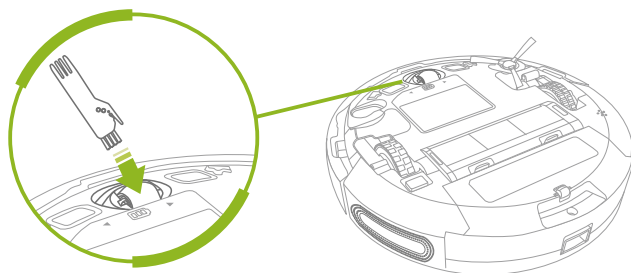

💡 Tip:

Do not clean the Omni-directional Wheel with water.

WATER TANK AND MOPPING CLOTH

Step 1:

Remove the **Mopping Cloth** from the water tank and wash it.

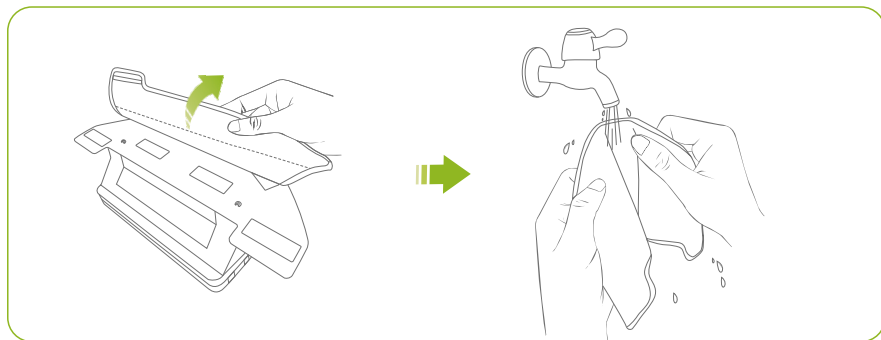

Step 2:

Empty the remaining water and rinse the **Water Tank** to clean it.

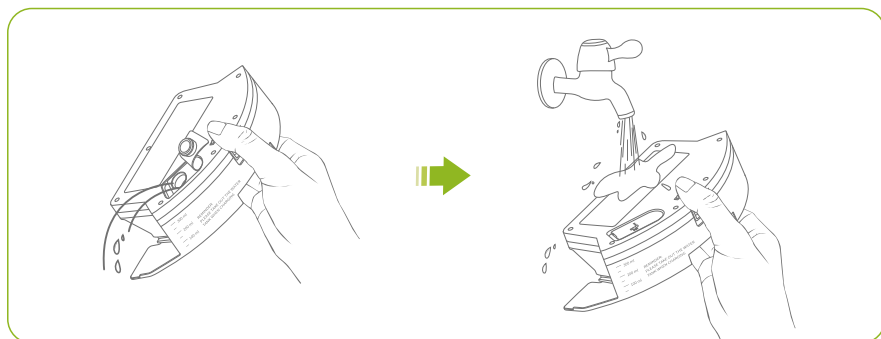

Step 3:

Air-dry the water tank and mopping cloth.

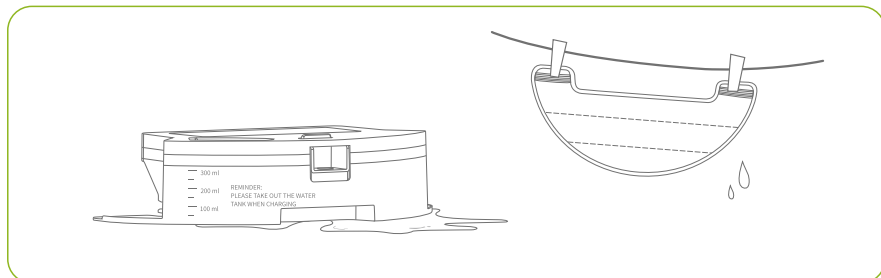

Step 4:

Stick the **Mopping Cloth** and fix it to the bottom of the **Water Tank**.

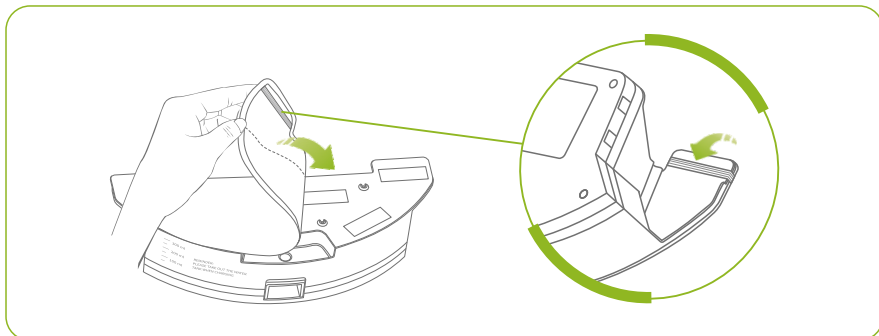
**! Notes:**

1. Do not use hot water or any cleaning solution to clean the water tank, which will cause damage to it.
2. Do not use hot water to clean the mopping cloth.

SPECIFICATIONS

Robot	Power Input	DC 19V $\overline{\text{---}}$ 0.6A
	Power Consumption	28W
	Battery Type	DC 14.4V Li-ion Battery
	Battery Capacity	3200mAh
	Charging Time	6-6.5Hours
	Suction Power	Three Levels
	Capacity of Dust Bin	600ML
	Cleaning Time	150 Minutes for Auto Mode with the minimum suction power on the hard floor after the battery is fully charged
Charging Base	Power Input/Output	DC 19V $\overline{\text{---}}$ 0.6A
Water Tank	Capacity	300ML

TROUBLESHOOTING GUIDE

If you need any further assistance, please feel free to contact us at support@kyvol.com.

FREQUENTLY ASKED QUESTIONS

Q1. The robot doesn't respond.

- * Make sure you press the **Power Switch** to ON.
- * Make sure the battery of your robot is not critical low.
- * Check if the batteries in the remote have enough power when it's controlled by the remote.
- * Make sure the distance between the remote and the robot is within the effective range (5m/16ft) when it's controlled by the remote.

Q2. The remote doesn't work.

- * Check if the batteries in the remote have enough power.
- * Make sure you press the **Power Switch** to ON.
- * Make sure the battery of the robot is not critical low or it doesn't drain completely.
- * Make sure the distance between the remote and the robot is within the effective range.

Q3. The robot stops working suddenly.

- * Verify if the robot is trapped or gets stuck.
- * Check if the battery of the robot is critical low.
- * Make sure you did not pause the robot.

Q4. The robot cannot start the scheduled cleaning.

- * Make sure you press the **Power Switch** to ON.
- * Check if the scheduled time is set correctly(AM/PM).
- * Check if the battery of the robot is low or critical low.
- * Check if you've cancelled the schedule.
- * If the status of the robot is abnormal(see page 29-30), it can't start the scheduled cleaning.

Q5. The suction power is weak.

- * There are three levels of suction power available for this model. Please try to press **(MIN)** / **(MAX)** on the remote to adjust the level.
- * Empty the **Dust Bin** and clean the **Filter**.
- * Replace the HEPA inside of the **Filter**.

Q6. The robot produces loud or sharp noises.

- * The robot will produce some certain sound when cleaning, which is normal. Please arrange your cleaning time to avoid being interrupted by the sound.
- * If a sharp noise is heard, please check if the **Main Brush** or the **Side Brush** is tangled with any objects.
- * Check if the robot collected the objects that can make noise inside of the **Dust Bin**.
- * When the robot needs your help, it will beep. You can check what's happened to it.

Q7. The robot won't charge.

- * Check if the **Power Indicator** on the **Charging Base** lit up.
- * Make sure the **Charging Contacts** on the robot are aligned with those on the **Charging Base**.
- * Clean the **Charging Contacts** with a dry cloth(alcohol is not recommended).

Q8. The robot cannot return to the Charging Base.

- * Remove the obstacles around the **Charging Base** so that the robot can detect where it is.
- * Check if there is a long distance between the robot and the **Charging Base**. If yes, the journey will take more time.
- * Check if the battery of the robot is critical low.
- * Clean the part where there are sensors on the **Bumper** and the **Charging Base**.

Q9. The Main Brush on the bottom of the robot cannot work.

- * Check if the brush is stuck by some objects; if yes, please remove them and clean the brush.
- * Make sure the brush and its guard are installed properly.

Q10. The route created by the robot is not described as instructed.

- * The gyroscope or the optical flow sensor is abnormal. Please place the robot on a flat surface and reboot it; check whether there is dust or oil residue left on the cover of the optical flow sensor.
- * The robot is finding and returning to the **Charging Base**.
- * Please directly contact us.

Q11. The cleaning time becomes shorter or less than 100 minutes.

- * The cleaning time varies with the cleaning mode, the suction power level and the material type of the surface.
- * If the robot is not fully charged, the cleaning time will be shorter.

A GUIDE TO INDICATORS AND BEEPS

When your robot needs help or attention, it will beep and the indicators on it will change accordingly to tell you what to check.



Solid Red Indicators

Beep(s)	Likely Cause	Solution
1 beep	The Left/Right Wheel of your robot is being stucked.	Power off your robot, then remove the objects that are wrapping the wheel.
2 beeps	The Side Brush of your robot is being stucked.	Power off your robot, then remove the the objects that are wrapping the Side Brush .
3 beeps	The suction inlet of your robot is being blocked.	Power off the robot, then remove and empty the Dust Bin . Make sure there is no hair or debris blocking the suction inlet.
4 beeps	The Main Brush on the bottom of your robot is being stucked.	Power off the robot, then remove the objects that are wrapping the Main Brush .

Flashing Red Indicators

Beep(s)	Likely Cause	Solution
1 beep	The gyroscope or the optical flow sensor is abnormal.	Please place the robot on a flat surface and reboot it; check whether there is dust or oil residue left on the cover of the optical flow sensor.

2 beeps	The Bumper of your robot loses the elasticity.	Please gently press the left, middle and right part of the bumper to check whether it can pop out.
3 beeps	The Anti-drop Sensors of the robot are covered or dirty.	Please clean the Anti-drop Sensors with a damp cloth.
4 beeps	The battery of your robot gets critical low.	Please manually get your robot to the Charging Base to fully charge it.

Operation Frequency	IEEE 802.11b/g: 2412 ~ 2472 MHz IEEE 802.11n HT20: 2412 ~ 2472 MHz IEEE 802.11n HT40: 2422 ~ 2462 MHz
Transmit Power(EIRP)	≤ 20dBm

FCC Caution

Any Changes or modifications not expressly approved by the party responsible for compliance could void the user's authority to operate the equipment.

This device complies with part 15 of the FCC Rules. Operation is subject to the following two conditions:

- (1) This device may not cause harmful interference, and
- (2) this device must accept any interference received, including interference that may cause undesired operation.

! Note:

This equipment has been tested and found to comply with the limits for a Class B digital device, pursuant to part 15 of the FCC Rules. These limits are designed to provide reasonable protection against harmful interference in a residential installation. This equipment generates, uses and can radiate radio frequency energy and, if not installed and used in accordance with the instructions, may cause harmful interference to radio communications. However, there is no guarantee that interference will not occur in a particular installation. If this equipment does cause harmful interference to radio or television reception, which can be determined by turning the equipment off and on, the user is encouraged to try to correct the interference by one or more of the following measures:

- Reorient or relocate the receiving antenna.
- Increase the separation between the equipment and receiver.
- Connect the equipment into an outlet on a circuit different from that to which the receiver is connected.
- Consult the dealer or an experienced radio/TV technician for help.

This equipment complies with FCC radiation exposure limits set forth for an uncontrolled environment. This equipment should be installed and operated with minimum distance 20cm between the radiator & your body.

This transmitter must not be co-located or operating in conjunction with any other antenna or transmitter.

ISED Warning

This device complies with Industry Canada licence-exempt RSS standard(s). Operation is subject to the following two conditions:

- (1) this device may not cause interference, and
- (2) this device must accept any interference, including interference that may cause undesired operation of the device.

Le présent appareil est conforme aux CNR d'Industrie Canada applicables aux appareils radio exempts de licence. L'exploitation est autorisée aux deux conditions suivantes :

- (1) l'appareil ne doit pas produire de brouillage, et
- (2) l'utilisateur de l'appareil doit accepter tout brouillage radioélectrique subi, même si le brouillage est susceptible d'en compromettre le fonctionnement.

The device is compliance with RF exposure guidelines, users can obtain Canadian information on RF exposure and compliance. The minimum distance from body to use the device is 20cm.

Le présent appareil est conforme Après examen de ce matériel aux conformité ou aux limites d'intensité de champ RF, les utilisateurs peuvent sur l' exposition aux radiofréquences et la conformité and compliance d'acquérir les informations correspondantes.

La distance minimale du corps à utiliser le dispositif est de 20cm.

CAUTION

RISK OF EXPLOSION IF BATTERY IS REPLACED BY AN INCORRECT TYPE

DISPOSE OF USED BATTERIES ACCORDING TO THE INSTRUCTIONS



The symbol indicates DC voltage



RECYCLING

This product bears the selective sorting symbol for Waste electrical and electronic equipment (WEEE). This means that this product must be handled pursuant to European directive 2012/19/EU in order to be recycled or dismantled to minimize its impact on the environment. This product can be used across EU member states.



CUSTOMER SUPPORT

North America : support@kyvol.com

United Kingdom : support.uk@kyvol.com



[@kyvolglobal](https://www.facebook.com/kyvolglobal)



www.kyvol.com



[@kyvol_global](https://www.instagram.com/kyvol_global)