

# Utility Cart Instruction Manual

V2.0(D)

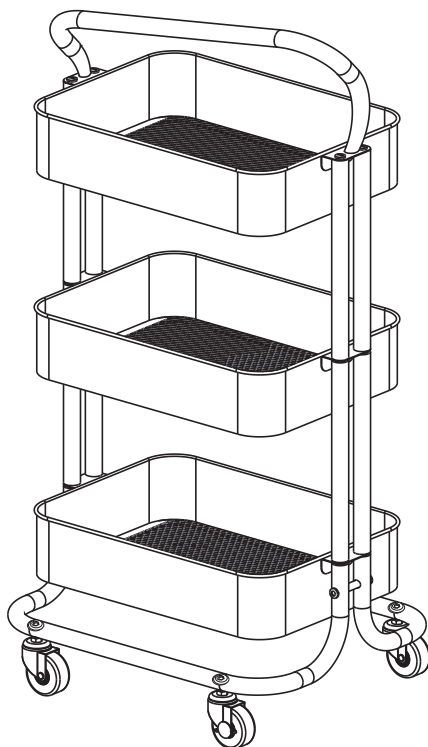

**Model: PIUC03B/PIUC03W**

English	-----	01-03
Français	-----	04-06

Thank you for choosing this product! We strive to provide you with the best quality products and services in the industry. Should you have any issues, please don't hesitate to contact us at

**Technical Support:**







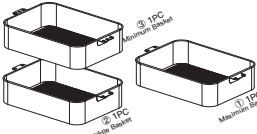
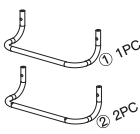
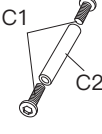

(US/CA) 1-800-556-9829 Mon-Fri 8am - 8pm(CST)

(UK) 44-808-196-3885 Mon-Fri 2pm - 10pm(UTC)

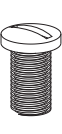
Other Info: [support@pipishell.net](mailto:support@pipishell.net)

Website: [www.pipishellav.com](http://www.pipishellav.com)

## Supplied Parts and Hardware List

 <p><b>Basket</b></p> <p>A 3 PCS</p>	 <p><b>Bent Tube</b></p> <p>B 3 PCS</p>	 <p><b>Bolt</b></p> <p>C 2 PCS</p>	 <p><b>Side Pole</b></p> <p>D 8 PCS</p>	 <p><b>Double Headed Bolt</b></p> <p>E 8 PCS</p>	 <p><b>Bolts</b></p> <p>F 4 PCS</p>
 <p><b>Castor with Brake</b></p> <p>2 PCS</p>	 <p><b>Castor without Brake</b></p> <p>2 PCS</p>	 <p><b>Wrench</b></p> <p>H 1 PC</p>	 <p><b>Allen Key</b></p> <p>J 1 PC</p>	 <p><b>Bolts</b></p> <p>K 2 PCS</p>	 <p><b>M6x10mm Rivet Nut</b></p> <p>L 4 PCS</p>

## ASSEMBLY STEPS

**Step 1** Screw 4 double-headed bolts [E] into the 2 bent tubes [B②], then slide a basket [A①] via the 4 double-head bolts [E].

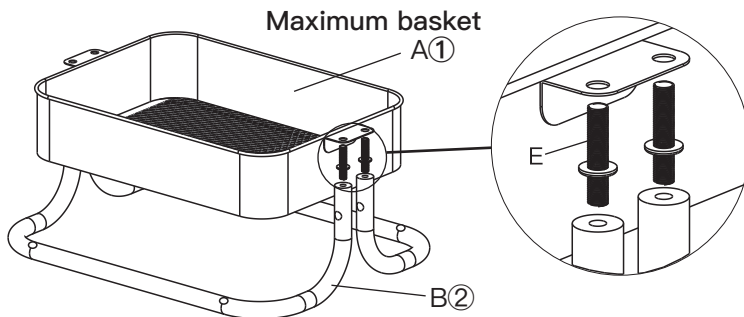

**Step 2** Fix the bolts [C] through the holes of bent tubes to fasten the two bent tubes using allen key [J].

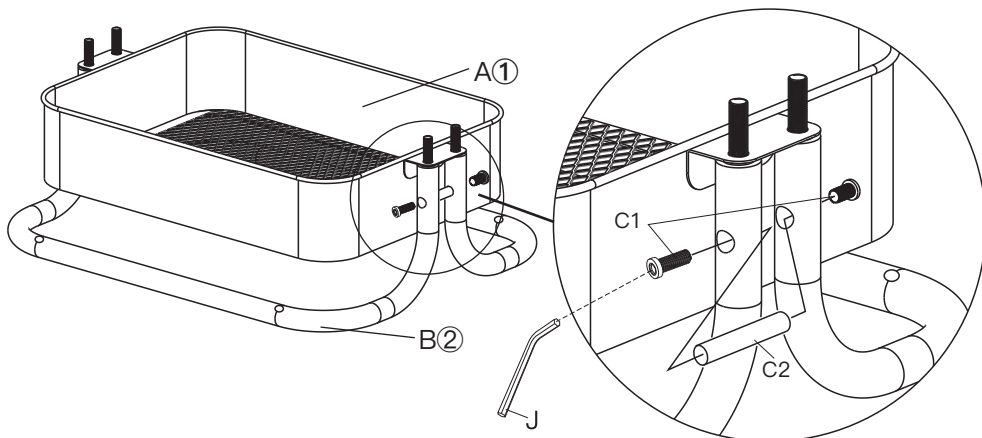

**Step 3** Screw the 4 side poles [D] into the 4 double-headed bolts [E]. Then screw another 4 double-headed bolts [E] to the top of the side poles [D] and slide the second basket [A②] to the double-headed bolts. Finally screw another 4 side poles [D] into the 4 double-headed bolts [E].

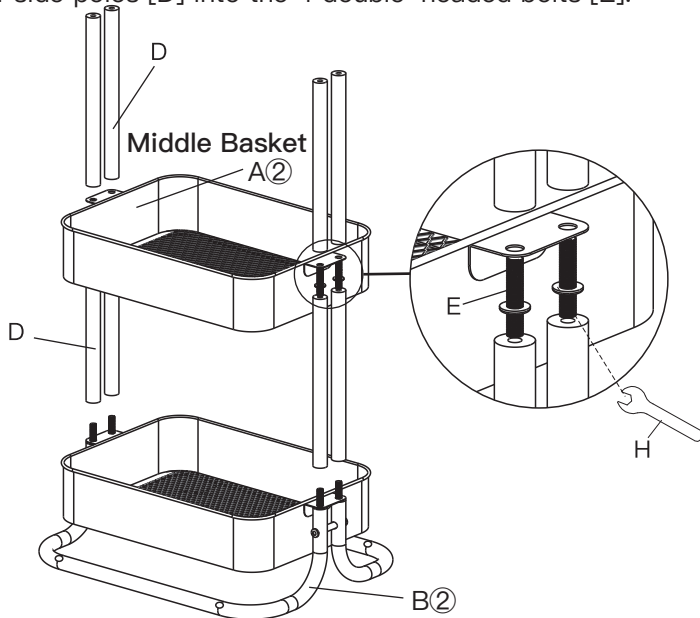

**Step 4** Secure the basket [A③] to the 4 side poles [D] using bolts [F]. Then secure the bent tube [B①] using bolts [K], making sure the holes on bent tube [B①] are aligned with the middle holes on the basket [A③].

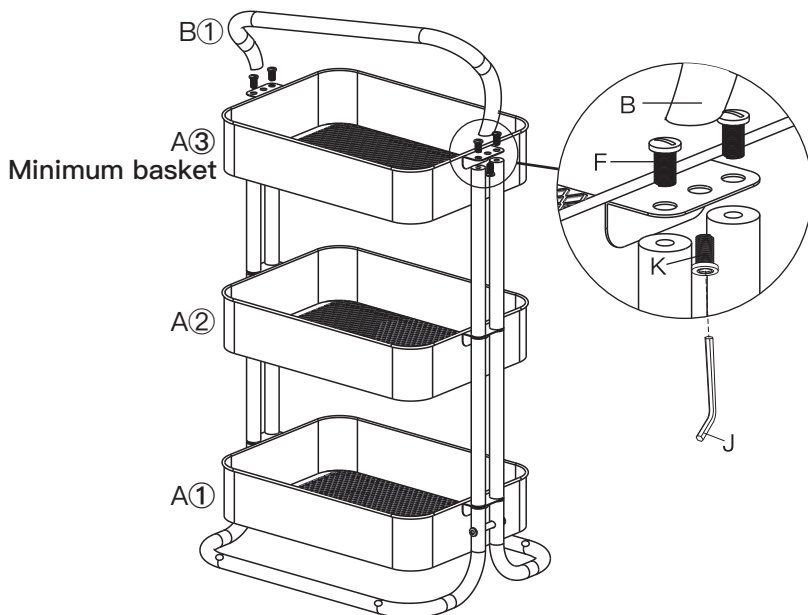

## Step 5

Insert the four rivet nuts [L] into the four holes on the bent tubes [B②]. Fix the rivet nut [L] using Allen key [J] while screwing the castor [G] onto the rivet nut [L] using wrench [H]. Or fix the castor using wrench [H] while tightening the rivet nut [L] using Allen key [J].

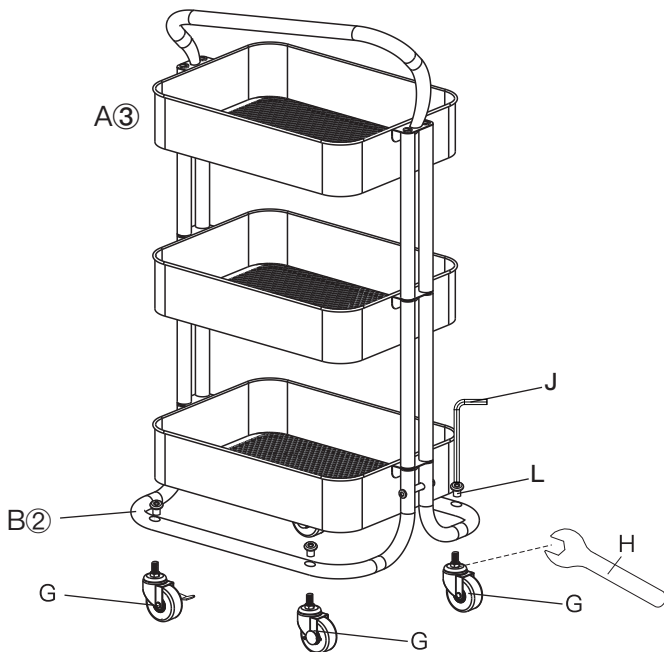

## Step 6

Finished

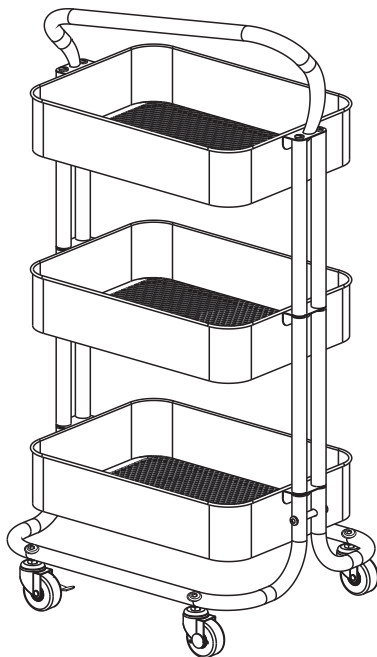

## List des matériels et pièces

<b>Panier</b>  A 3 PCS		<b>tube coudé</b>  B 3 PCS	<b>Boulon C1</b>  C 2 PCS	<b>Poteau latéral</b>  D 8 PCS	<b>Boulon à double tête</b>  E 8 PCS	<b>Boulon</b>  F 4 PCS
<b>Avec roulette frein</b>  2 PCS	<b>Sans roulette frein</b>  2 PCS	<b>Clé</b>  1 PC	<b>clé Allen</b>  J 1 PC	<b>Boulon</b>  K 2 PCS	<b>M6x10mm Écrou rivet</b>  L 4 PCS	

## Étapes montage

**Étape 1** Visser quatres boulons [E] à double tête sur les deux tubes coudés [B(2)], puis baisser le panier [A(1)] par les quatres boulons [E].

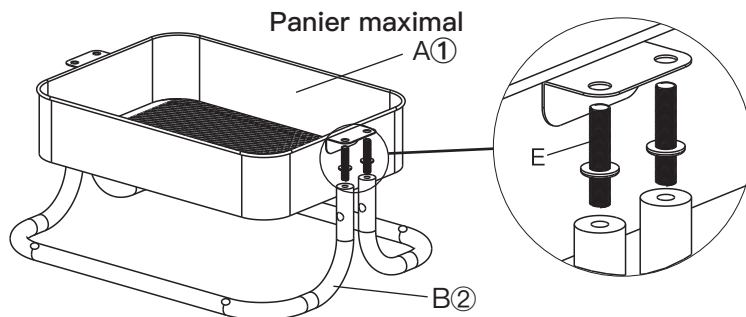

**Étape 2** Fixer les boulons [C] à travers les trous de tubes coudés pour serrer les deux tubes coudés en utilisant clé Allen [J].

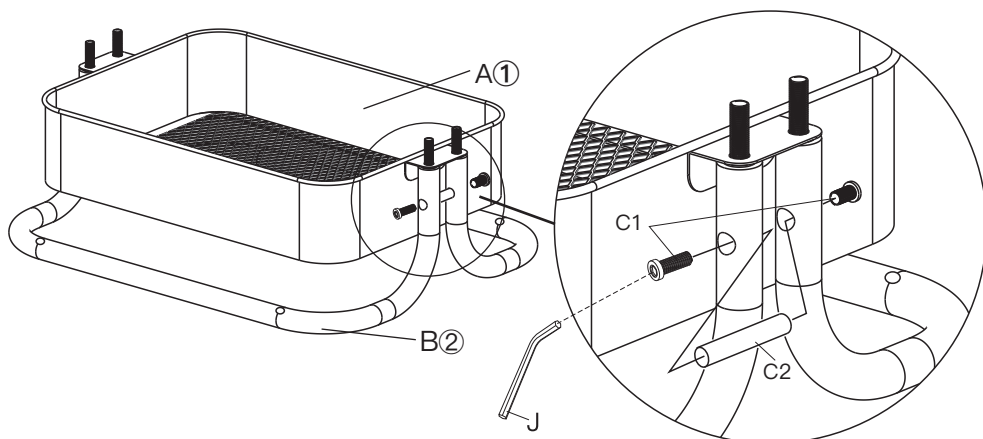

**Étape 3** Visser les quatres poteaux latéraux [D] dans les quatres boulons à double tête [E], puis visser les autres quatres boulons à double tête [E] dans la partie supérieure des poteaux latéraux [D] et baisser la deuxième panier dans les boulons à double tête. Au final, visser les autres quatres poteaux latéraux [D] dans les quatres boulons à double tête [E].

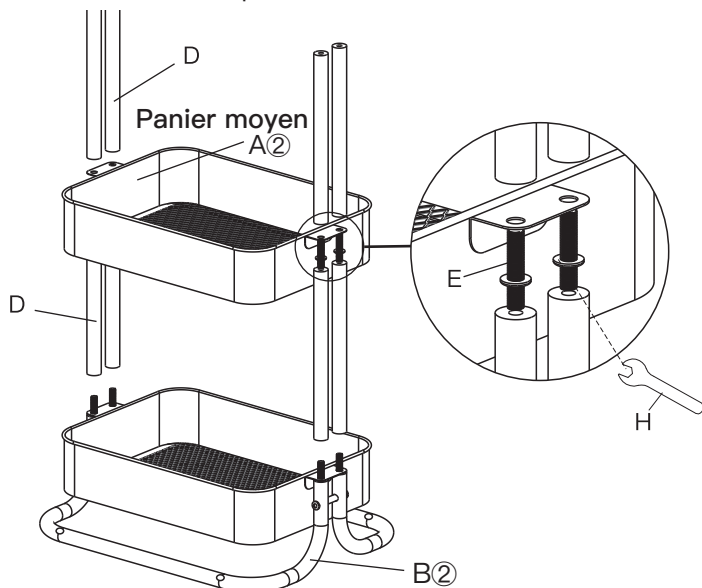

**Étape 4** Fixer la panier [A3] sur les quatres poteaux lateraux [D] en utilisant boulons [F]. Puis bien fixer le tube coudé [B1] en utilisant boulons [K], assurez-vous que les trous sur les tubes coudés sont alignés avec les trous au milieu de la panier [A3]

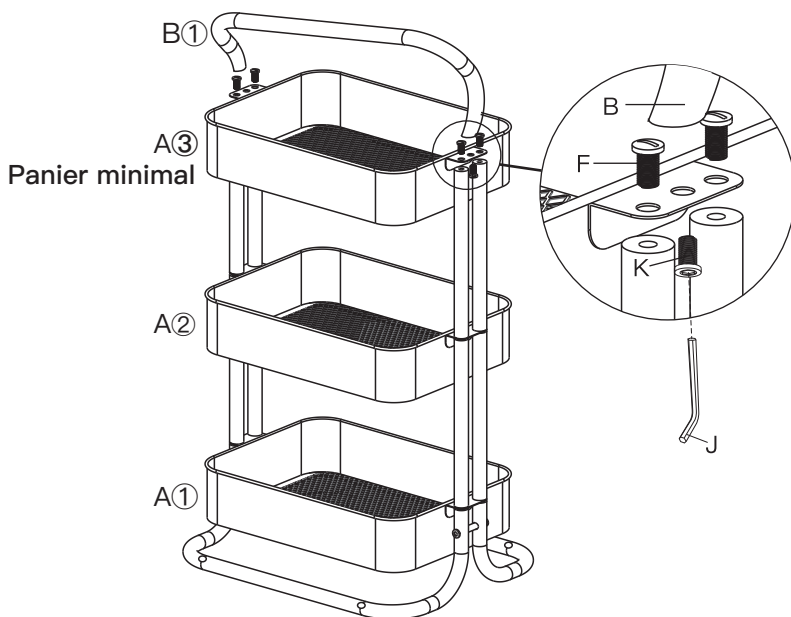

## Étape 5

Insérer les quatre écrous rivet [L] dans les quatre trous des tubes coudés [B②]. Fixer l'écrou rivet en utilisant clé Allen [J] lors que visser la roulette [G] dans l'écrou rivet [L] en utilisant clé [H]. Ou fixer la roulette en utilisant clé [H] lors que serrer le nut revit [L] en utilisant clé Allen.

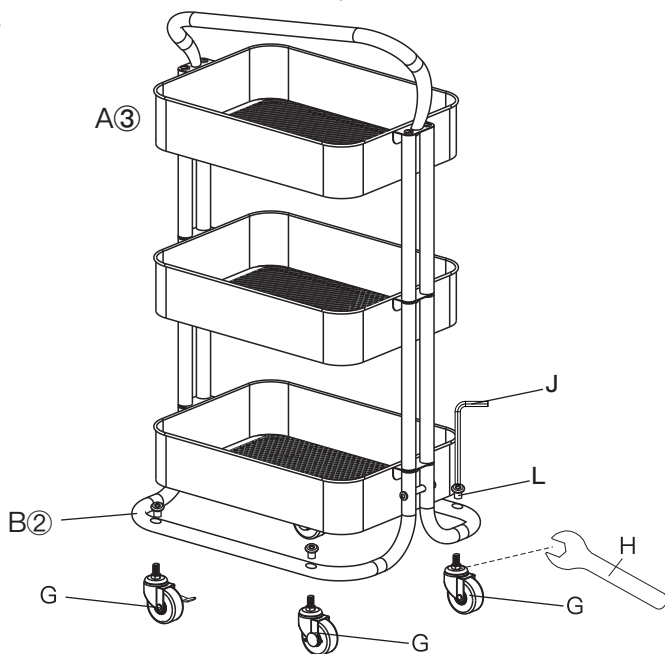

## Étape 6

Fini

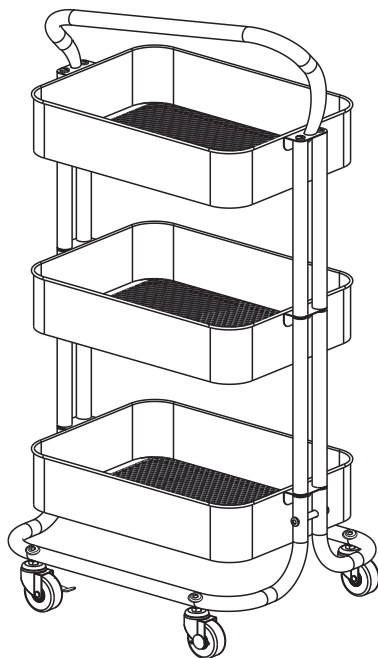

# Thank you again for choosing this product!

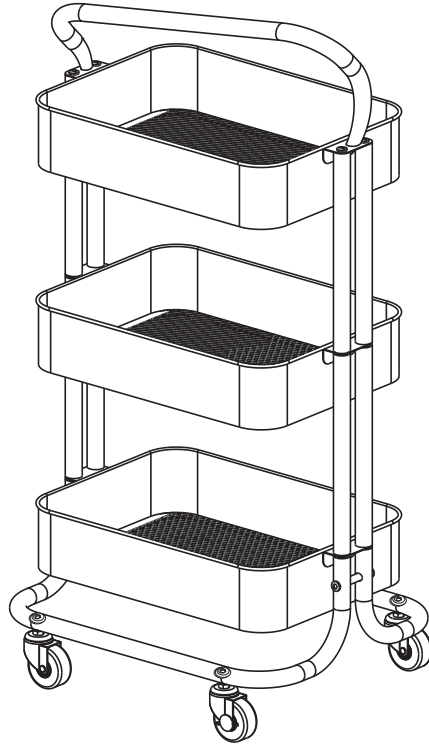

All of us do appreciate your product purchase. We hope that you are as happy with your product as we designing and manufacturing it for you. We strive to provide you with the best quality products and services in the industry. If you have any questions please don't hesitate to contact us at

**Technical Support:**

**(US/CA)1-800-556-9829 Mon-Fri 8am – 8pm(CST)**

**(UK)44-808-196-3885 Mon-Fri 2pm – 10pm(UTC)**

**Other Info: [support@pipishell.net](mailto:support@pipishell.net)**

**Website: [www.pipishellav.com](http://www.pipishellav.com)**