

EN OWNER'S MANUAL /

Instructions for Assembly '5x8 YardMate Plus'
Size 5Ft x 8Ft / 1.7 m x 2.5 m (Approx.)
Ver: 1.0

FR MANUEL D'INSTRUCTION/

Instructions pour l'Assemblage '5x8 YardMate Plus'
Dimension 5Pieds x 8Pieds / 1.7 Mètre x 2.5 Mètre (Approx.)
Ver: 1.0

DE Benutzerhandbuch /

Montageanleitung '5x8 YardMate Plus'
Größe: 5Ft x 8Ft / 1.7 m x 2.5 m (Ca.)
Ver: 1.0

ES MANUAL DEL PROPIETARIO/

Instrucciones de montaje '5x8 YardMate Plus'
Tamaño 5Pies x 8Pies / 1.7 Metros x 2.5 Metros (Aprox.)
Ver: 1.0

PT MANUAL DO PROPRIETÁRIO/

Instruções de montagem '5x8 YardMate Plus'
Tamanho 5pés x 8pés / 1.7 Metro x 2.5 Metro (Aprox.)
Ver: 1.0

NL Gebruiksaanwijzing voor eigenaar/

Instructies voor bouw '5x8 YardMate Plus'
Maat 5 voet x 8 voet / 1.7 Meter x 2.5 Meter (Ongeveer)
Versie: 1.0

CS Příručka uživatele /

Návod k montáži '5x8 YardMate Plus'
Velikost 5 Stopy x 8 Stopy / 1.7 Metr x 2.5 Metr (Přibližně)
Verze : 1.0

SK NÁVOD PRE UŽÍVATELA /

Návod na zloženie '5x8 YardMate Plus'
Velkost' 5Stopa x 8Stopa / 1.7 m x 2.5 m (približne)
Pozri: 1.0

SL PRIROČNIK ZA LASTNIKA /

Navodila za montažo '5x8 YardMate Plus'
Velikost 5Čevljev x 8Čevljev / 1.7 Metrov x 2.5 Metrov (Približno)
Razl: 1.0

HR Gazdinski Priručnik /

Instrukcije za skupštine '5x8 YardMate Plus'
Veličina 5Stopalo x 8 Stopalo/ 1.7 Metar x 2.5 Metar (Približno)
Ver: 1.0

HU FELHASZNÁLÓI KÉZIKÖNYV /

Útmutató az összeszereléshez '5x8 YardMate Plus'
5Láb x 8Láb / 1.7 Méter x 2.5 Méter (Hozzávetőlegesen)
Verzió: 1.0

SV ÄGARENS MANUAL/

Monteringsinstruktioner för '5x8 YardMate Plus'
Storlek 5 fot x 8 fot / 1.7 m x 2.5 m (Ungefär)
Version: 1.0

IT MANUALE DEL PROPRIETARIO /

Istruzioni per l'assemblaggio '5x8 YardMate Plus'
Dimensione 5 Piedi x 8 Piedi / 1.7Metri x 2.5Metri (Circa)
Versione 1.0

PL PODRĘCZNIK UŻYTKOWNIKA /

Instrukcja montażu '5x8 YardMate Plus'
Wymiary 5Stopy x 8Stopy / 1.7 Metr x 2.5 Metr (W przybliżeniu)
Wersja: 1.0

RO MANUAL DE UTILIZARE /

Instrucțiuni de asamblare '5x8 YardMate Plus'
Mărime 5Picioare x 8Picioare / 1.7 Metri x 2.5 Metri (Aprox.)
Ver: 1.0

BG РЪКОВОДСТВО ЗА ПРИТЕЖАТЕЛЯ /

Инструкции за сглобяване '5x8 YardMate Plus'
Размер 5 Фута x 8 Фута / 1.7 Метра x 2.5 Метра (приблизително)
Версия: 1.0

TR KULLANIM KILAVUZU /

Montaj Talimatları '5x8 YardMate Plus'
5Fit x 8Fit / 1.7m x 2.5m (Yaklaşık olarak)
Sürüm: 1.0

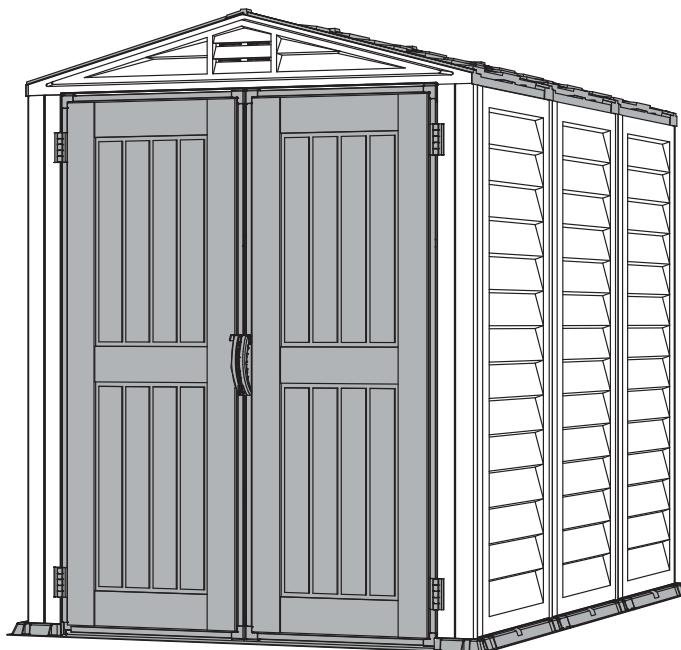
**Model # 35825-1**

EN

Building Dimensions :

Approximate Size	Storage		Exterior Dimension				Interior Dimension		Door Opening		
	Area	Volume	Base Dimension		Roof Edge to Edge		Wall to Wall				
			inch	cm	inch	cm	inch	cm	inch	cm	
5 Ft x 8 Ft	39 1/4 Sq. Ft	236 1/4 Cu.Ft	Width	67 1/4	171	63 1/2	161.1	61 1/4	155.6	52 3/4	134
1.7 m x 2.5 m	3.6 Sq.m	6.7 Cu.m	Depth	98 1/2	250	96 1/4	244.4	92 3/8	234.6		
			Height			82 3/4	209.8	72	183	70 7/8	180

Snow load tested max. 20lbs / sq.foot (As per IP Standard)
 "We recommend to clear snow from the Roof top after each Snowfall."
 A snow depth of more than 10cm can become hazardous!

FR

Dimensions du bâtiment :

Taille approximative	Stockage		Dimension extérieure				Dimension intérieure		Ouverture de porte		
	Secteur	Volume	Dimension de base		Toit de bord au bord		Mur à mur				
			pouce	cm	pouce	cm	pouce	cm	pouce	cm	
5 Pieds x 8 Pieds	39 1/4 Carré pieds	236 1/4 Pieds cube	Largeur	67 1/4	171	63 1/2	161.1	61 1/4	155.6	52 3/4	134
1.7 Mètre x 2.5 Mètre	3.6 Mètre carré	6.7 Mètre cube	Profondeur	98 1/2	250	96 1/4	244.4	92 3/8	234.6		
			Hauteur			82 3/4	209.8	72	183	70 7/8	180

Charge de neige testé max. 20lbs / Carré pieds (conformément à la norme IP) /
 "Nous recommandons d'enlever la neige du Toit après chaque Enneigement."
 Une épaisseur de neige de plus de 10cm peut devenir dangereux!

DE

Gebäude Abmessung:

Ungefähre Größe	Speicher		Außen Abmessung				Innen Abmessung		Türöffnung		
	Bereich	Volumen	Fundament Abmessung		Dach Kante bis Kante		(von Wand zu Wand)				
			inch	cm	inch	cm	inch	cm	inch	cm	
5 Ft x 8 Ft	39 1/4 Sq. Ft	236 1/4 Cu.Ft	Breite	67 1/4	171	63 1/2	161.1	61 1/4	155.6	52 3/4	134
1.7 m x 2.5 m	3.6 Sq.m	6.7 Cu.m	Tiefe	98 1/2	250	96 1/4	244.4	92 3/8	234.6		
			Höhe			82 3/4	209.8	72	183	70 7/8	180

Schneelast max. getestet. 20lbs /sq.Foot (gem. Standard IP)
 "Wir empfehlen liegenden Schnee nach jedem Schneefall vom Dach abzuräumen."
 Eine Schneetiefe von mehr als 10cm kann gefährlich werden!

ES

Medidas de la caseta:

El Tamaño a proximado	Área de almacenaje		Dimensión exterior				Dimensión interior		Abertura de la puerta		
	Área	Volumen	Dimensión de la base		Borde de la azotea al borde		pared a pared				
			Pulgada	cm	Pulgada	cm	Pulgada	cm	Pulgada	cm	
5 Pies x 8 Pies	39 1/4 Pies cuadrados	236 1/4 Pies Cúbicos	Anchura	67 1/4	171	63 1/2	161.1	61 1/4	155.6	52 3/4	134
1.7 Metros x 2.5 Metros	3.6 Metros cuadrados	6.7 Metros Cúbicos	Profundidad	98 1/2	250	96 1/4	244.4	92 3/8	234.6		
			Altura			82 3/4	209.8	72	183	70 7/8	180

Carga de nieve probado max. 20lbs / Pies cuadrados (97,5 kgf/m²)(según el estándar de IP)
 "Se recomienda limpiar la nieve del tejado después de cada nevada."
 Una altura de nieve de más de 10cm puede llegar a ser peligrosa!

PT

Área de Construção:

Dimensão aproximada	Área de Arrumação		Dimensão Exterior				Dimensão Interior		Abertura da Porta		
	Área	Volume	Dimensão da base		Amplitude do Telhado		(Parede a Parede)				
			Polegada	centímetro	Polegada	centímetro	Polegada	centímetro	Polegada	centímetro	
5 pés x 8 pés	39 1/4 Pies quadrado	236 1/4 Pies cúbico	Comprimento	67 1/4	171	63 1/2	161.1	61 1/4	155.6	52 3/4	134
1.7 Metro x 2.5 Metro	3.6 Metro quadrado	6.7 Metro cúbico	Profundidade	98 1/2	250	96 1/4	244.4	92 3/8	234.6		
			Altura			82 3/4	209.8	72	183	70 7/8	180

Carga de neve testado max. 20lbs / Pies quadrado (conforme padrão IP).
 "Recomendamos limpar a neve do topo do telhado após cada queda de neve."
 Uma profundidade de neve de mais de 10cm pode tornar-se perigosa!

NL

Gebouw afmeting:

Benadering Maat	Opslag		Buitenkant afmeting				Binnenkant afmeting		Deur opening		
	Gebied	Volume	Basis afmeting		Dakrand tot rand		Muur tot muur				
			inch	cm	inch	cm	inch	cm	inch	cm	
5 Voet x 8 Voet	39 1/4 Vierkante voet	236 1/4 Kubieke voet	Wijde	67 1/4	171	63 1/2	161.1	61 1/4	155.6	52 3/4	134
1.7 m x 2.5 m	3.6 Vierkante meter	6.7 Kubieke meter	Diepte	98 1/2	250	96 1/4	244.4	92 3/8	234.6		
			Hoogte			82 3/4	209.8	72	183	70 7/8	180

Sneeuw belasting getest max. 20lbs / Vierkante voet (volgens het standaard IP-).

“We raden aan sneeuw uit het dak te verwijderen na elke sneeuwval.”

Een sneeuwdiepte van meer dan 10 cm kan gevaarlijk worden!

CS

Budova rozměr

Přibližné rozměry	Skladování		Vnější rozměr				Vnitřní rozměr		Otevírání dveří		
	Plocha	Objem	Základní rozměr		Na okraj střechy edge		Zdi ke zdi				
			inch	cm	inch	cm	inch	cm	inch	cm	
5 Stopy x 8 Stopy	39 1/4 Čtvereční Stopy	236 1/4 Krychlový Stopy	Šířka	67 1/4	171	63 1/2	161.1	61 1/4	155.6	52 3/4	134
1.7 Metr x 2.5 Metr	3.6 Čtvereční metr	6.7 Krychlový Metr	Hloubka	98 1/2	250	96 1/4	244.4	92 3/8	234.6		
			Výška			82 3/4	209.8	72	183	70 7/8	180

Zkouška zatížení sněhu max. 20lbs / Čtvereční Stopy (podle normy IP).

“Doporučujeme odstranit sníh ze střešního krytu po každém sněžení.”

Možná hloubka sněhu větší než 10 cm může být nebezpečná!

SK

Stavebné rozmer

Približné veľkosti	Sklad		Vonkajší rozmer				Interiér rozmer		Otvorenie dverí		
	Priestor	Objem	Base rozmer		Strešné okraja k okraju		Zdi k múru				
			inch	cm	inch	cm	inch	cm	inch	cm	
5 Stopa x 8 Stopa	39 1/4 Stopa štvorcový	236 1/4 Stopa kubický	Šírka	67 1/4	171	63 1/2	161.1	61 1/4	155.6	52 3/4	134
1.7 m x 2.5 m	3.6 Meter štvorcový	6.7 Meter kubický	Hĺbka	98 1/2	250	96 1/4	244.4	92 3/8	234.6		
			Výška			82 3/4	209.8	72	183	70 7/8	180

Testovanie zaťaženia snehu max. 20lbs / Stopa štvorcový (podľa IP štandardu).

“Odporúčame odstrániť sneh zo strechy po každej snehu.”

Z hĺbky snehu väčšej ako 10 cm sa môže stať nebezpečné!

SL

Zidanje obseg

približno velikost	Skladiščenje		zunanji obseg				notranji obseg		vrata predrtina		
	Območje	Prostorina	osnova obseg		streha rob v rob		obdati obzidati				
			cola	cm	cola	cm	cola	cm	cola	cm	
5 Čevljev x 8 Čevljev	39 1/4 Kvadratnih Čevljev	236 1/4 Kubičnih Čevljev	širina	67 1/4	171	63 1/2	161.1	61 1/4	155.6	52 3/4	134
1.7 Metrov x 2.5 Metrov	3.6 Kvadratnih Metrov	6.7 Kubičnih Metrov	globina	98 1/2	250	96 1/4	244.4	92 3/8	234.6		
			višina			82 3/4	209.8	72	183	70 7/8	180

Snow obremenitev testiran max. 20lbs / Kvadratnih Čevljev (po standardu IP).

“Priporočamo, da počistite sneg z vrha strehe po vsakem sneženju.”

Z globino snega več kot 10 cm lahko postane nevarno!

HR

Zgrada dimenzija

Približno određena mjera	Skladištenje		Vanjski dimenzija				Interijer dimenzija		Vrata Open		
	Područje	Svezak	Temeljiti dimenzija		Krov rub to rub		Zidni to zidni				
			inch	cm	inch	cm	inch	cm	inch	cm	
5 Stopalo x 8 Stopalo	39 1/4 Četvornih Stopalo	236 1/4 Kubni Stopalo	širina	67 1/4	171	63 1/2	161.1	61 1/4	155.6	52 3/4	134
1.7 Metar x 2.5 Metar	3.6 Četvornih Metar	6.7 Kubni Metar	dubina	98 1/2	250	96 1/4	244.4	92 3/8	234.6		
			visina			82 3/4	209.8	72	183	70 7/8	180

Testirano opterećenje max.20lbs / Četvornih Stopalo (prema IP standardu).

“Preporučujemo čišćenje snijega s vrha krova nakon svakog snijega.”

Nema dubine snijega veće od 10 cm može biti opasna!

HU

Építési dimenzió

Hozzávetőleges mérete	Tárolás		Külső méret				A belső dimenzió		Ajtónyitás		
	Terület	Mennyiség	Alap dimenzió		Tető élétől él		A fal és a fal				
			Hüvelyk	cm	Hüvelyk	cm	Hüvelyk	cm	Hüvelyk	cm	
5 Láb x 8 Láb	39 1/4 Négyzet Láb	236 1/4 Köb Láb	Szélesség	67 1/4	171	63 1/2	161.1	61 1/4	155.6	52 3/4	134
1.7 Méter x 2.5 Méter	3.6 Négyzet méter	6.7 Köbméter	Oldalmagasság	98 1/2	250	96 1/4	244.4	92 3/8	234.6		
			Magasság			82 3/4	209.8	72	183	70 7/8	180

A terhelés max. 20lbs / Négyzet Láb (IP-szabvány szerint).

“Javasoljuk, hogy minden hóesést követően tisztítsa meg a havat a tetőtől.”

A 10 cm-nél hosszabb hóvastagság veszélyessé válhat!

SV

Byggnadsdimensioner:

Ungefärlig storlek	Lager		Yttre dimensioner				Inre dimensioner		Dörröppning		
	Area	Volym	Basdimensioner		Tak kant till kant		Vägg till vägg				
			Tum	cm	Tum	cm	Tum	cm	Tum	cm	
5 fot x 8 fot	39 1/4 kvadrat fot	236 1/4 kubik fot	Bredd	67 1/4	171	63 1/2	161.1	61 1/4	155.6	52 3/4	134
1.7 m x 2.5 m	3.6 kvadratmeter	6.7 kubik meter	Djup	98 1/2	250	96 1/4	244.4	92 3/8	234.6		
			Höjd			82 3/4	209.8	72	183	70 7/8	180

Snow last testas max. 20lbs / kvadrat fot (enligt IP-standard).

“Vi rekommenderar att klara snö från taket efter varje snöfall.”

Ett snödjup på mer än 10 cm kan bli farligt!

IT

Dimensioni di Costruzione:

Dimensione approssimativa	Deposito		Dimensione Esterna				Dimensioni Interne		Apertura della Porta		
	Area	Volume	Dimensione della Base		Soffitto da Lato a Lato		Da Muro a Muro				
			Inches	Centimetri	Inches	Centimetri	Inches	Centimetri	Inches	Centimetri	
5 Piedi x 8 Piedi	39 1/4 Piedi Quadrati	236 1/4 Piedi Cubici	Ampiezza	67 1/4	171	63 1/2	161.1	61 1/4	155.6	52 3/4	134
1.7 Metri x 2.5 Metri	3.6 Metri Quadrati	6.7 Metri Cubici	Profondità	98 1/2	250	96 1/4	244.4	92 3/8	234.6		
			Altezza			82 3/4	209.8	72	183	70 7/8	180

Snow carico testato max. 20lbs / Piedi Quadrati (come per IP standard).

“We consigliamo di eliminare la neve dalla tetto del tetto dopo ogni nevicata.”

Una profondità di neve di oltre 10 cm può diventare pericolosa!

PL

Wymiary budowlane:

Przybliżone wymiary	Magazynowa		Wymiary zewnętrzne				Wymiary wewnętrzne		Otwieranie drzwi		
	Powierzchnia	Kubatura	Wymiary fundamentów		Dachu od krawędzi do krawędzi		od ściany do ściany				
			Cal	cm	inch	cm	inch	cm	inch	cm	
5 Stopy x 8 Stopy	39 1/4 Stopy kwadratowy	236 1/4 Stopy sześcienny	Szerokość	67 1/4	171	63 1/2	161.1	61 1/4	155.6	52 3/4	134
1.7 Metr x 2.5 Metr	3.6 Metr kwadratowy	6.7 Metr sześcienny	Głębokość	98 1/2	250	96 1/4	244.4	92 3/8	234.6		
			Wysokość			82 3/4	209.8	72	183	70 7/8	180

Testowane obciążenie śniegiem max. 20lbs (zgodnie ze standardem IP).
 “Po każdym opadzie śniegu zalecamy usuwanie śniegu z dachu”.
 Grubość śniegu powyżej 10 cm może być niebezpieczna!

RO

Cladirea dimensiuni

Dimensiunea aproximativa	Depozitarea		Dimensiunea exterioara				Dimensiunea interne		deschiderea usii		
	Suprafata	Volumul	Baza dimensiuni		Acoperisul marginea la marginea		perete in perete				
			inch	cm	inch	cm	inch	cm	inch	cm	
5 Picioare x 8 Picioare	39 1/4 Picioare pătrați	236 1/4 Picioare cubi	Latimea	67 1/4	171	63 1/2	161.1	61 1/4	155.6	52 3/4	134
1.7 Metri x 2.5 Metri	3.6 Metri pătrați	6.7 Metri cubi	Adancimea	98 1/2	250	96 1/4	244.4	92 3/8	234.6		
			Inaltimea			82 3/4	209.8	72	183	70 7/8	180

Rezultatea de încărcare maximă testată. 20lbs / Picioare pătrați (conform standardului IP).
 “Vă recomandăm să eliminați zăpada din partea superioară a acoperișului după fiecare zăpadă.”
 O adâncime de zăpadă mai mare de 10 cm poate deveni periculoasă!

BG

Сградата измерение

Ориентировачна размер	Съхранение		Външно измерение				Министърът на вътрешните измерение		Вратата отваряне		
	Площ	Обем	База измерение		Покрив край до край		Стената на стената				
			Инча	Сантиметра	Инча	Сантиметра	Инча	Сантиметра	Инча	Сантиметра	
5 Фута x 8 Фута	39 1/4 Квадратни Фута	236 1/4 Кубични Фута	Ширина	67 1/4	171	63 1/2	161.1	61 1/4	155.6	52 3/4	134
1.7 Метра x 2.5 Метра	3.6 Квадратни Метра	6.7 Кубични Метра	Дълбочина	98 1/2	250	96 1/4	244.4	92 3/8	234.6		
			Височина			82 3/4	209.8	72	183	70 7/8	180

Тестване на тежестта на снемане макс. 20lbs / Квадратни Фута (според IP Стандарт).
 “След всеки снеговалеж препоръчваме да изчистите снега от покрива на покрива.”
 Дълбочина на снега повече от 10 см може да стане опасна!

TR

İnşaat boyutu

Tahmini büyüklüğü	Depo		Diş boyutlar				İç boyutu		Kapı açılması		
	Alan	Hacim	Temel boyutundaki		sertliği için harekete		Duvarдан duvara				
			İnç	Santimetre	İnç	Santimetre	İnç	Santimetre	İnç	Santimetre	
5 Fit x 8 Fit	39 1/4 Metre Fit	236 1/4 Kübik Fit	Genişlik	67 1/4	171	63 1/2	161.1	61 1/4	155.6	52 3/4	134
1.7 m x 2.5 m	3.6 Metrekare	6.7 Kübik metre	Derinlik	98 1/2	250	96 1/4	244.4	92 3/8	234.6		
			Yükseklik			82 3/4	209.8	72	183	70 7/8	180

Saat yükü test max. 20lbs / Metre Fit (IP Standardına göre).
 “Her Kar yağışı sonrasında Çatı üstten kar temizlemenizi öneririz.”
 Kar derinliği 10 cm'den fazla tehlikeli olabilir!

EN Tools You Will Need

- | | |
|----------------------------------|-----------------------------|
| 1. Cordless Drill - Philips Head | 6. Tape Measure |
| 2. Screwdriver - Philips Head | 7. Hand Gloves |
| 3. Carpenters Square | 8. Eye Protector |
| 4. 8' Step Ladder | 9. Waterproof Clear Silicon |
| 5. Level - 3ft. | 10. Hammer or Rubber mallet |

FR Outils dont vous aurez besoin

- | | |
|-------------------------------------|-----------------------------------|
| 1. Perceuse sans fil – Tête Philips | 6. Ruban à mesurer |
| 2. Tournevis - Tête Philips | 7. Gants |
| 3. Équerre du Menuisier | 8. Protecteur des Yeux |
| 4. Escabeau 8' | 9. Silicone neutre étanche |
| 5. Niveau - 3ft. | 10. Marteau ou maillet caoutchouc |

DE Benötigte Werkzeuge

- | | |
|---|---------------------------------|
| 1. Akku-Bohrschrauber - Kreuzschlitzbit | 6. Maßband |
| 2. Kreuzschlitz-Schraubenzieher | 7. Handschuhe |
| 3. Winkelmaß | 8. Schutzbrille |
| 4. 8' Leiter | 9. Wasserdichtes klares Silikon |
| 5. Wasserwaage – 1 m | 10. Hammer oder Gummihammer |

ES Herramientas necesarias para el montaje

- | | |
|--|--|
| 1. Atornillador eléctrico con cabeza estrella- | 6. Cinta métrica |
| 2. Destornillador estrella / Philips / Philips | 7. Use guantes de seguridad |
| 3. Gafas protectoras | 8. Escuadra |
| 4. Escalera de 8 peldaños | 9. Silicio transparente a prueba de agua |
| 5. Nivel de 1m | 10. Martillo o mazo de goma |

PT Ferramentas que irá precisar

- | | |
|------------------------------------|--------------------------------------|
| 1. Cordless Berbequim | 6. Fita Métrica |
| 2. Chave de fenda – cabeça estrela | 7. Luvas |
| 3. Esquadro de carpinteiro | 8. Protector Ocular |
| 4. Escadote 8' | 9. Silicone Transparente Impermeável |
| 5. 3ft. Nível | 10. martelo ou malho de borracha |

NL Gereedschappen die u nodig zult hebben

- | | |
|---|------------------------------|
| 1. Snoerloze boormachine met gekruiste kop | 6. Meetlint |
| 2. Snoerloze schroevendraaier met gekruiste kop | 7. Handschoenen |
| 3. Winkelhaak | 8. Oogbescherming |
| 4. Ladder met acht treden | 9. Waterdicht Clear Silicone |
| 5. Waterpas | 10. Hamer of rubberen hamer |

CS Budete potřebovat toto nářadí

- | | |
|---------------------------------|----------------------------|
| 1. Bezdrátová vrtačka - Philips | 6. Svinovací metr |
| 2. Vrták - Philips | 7. Rukavice |
| 3. Tesařské náměstí | 8. Ochranné brýle |
| 4. 8mí stupňový žebřík | 9. Vodotěsný čistý silikon |
| 5. Vodováha - 3ft. | 10. Kladivo nebo kaučuk |

SK Nástroje, ktoré budete potrebovať

- | | |
|--------------------------------------|----------------------------------|
| 1. Bezdrôtová vrtačku - Philips Head | 6. Meter |
| 2. Šraubovák – Philips Head | 7. Rukavice |
| 3. Stolársky meter | 8. Ochrana na oči |
| 4. 8' Rebrík | 9. Vodotesný čistý silikón |
| 5. Zdvihák – 3 stopy. | 10. Kladivo alebo gumená palička |

SL Orodje, ki ga boste potrebovali

- | | |
|------------------------------------|-----------------------------------|
| 1. Brezžična vrtalna- glava Philip | 6. Merilni trak |
| 2. Vijačnik-glava Philip | 7. Rokavice |
| 3. Mizarski kvadrat | 8. zaščitna očala |
| 4. 2438,4 mm dvokraka lestev | 9. Vodoodporni Clear Silikon |
| 5. Nivelirka - 0,91 m | 10. Kladivo za kladivo ali kavčuk |

HR Alati, Trebat će Vam

- | | |
|--------------------------------------|----------------------------------|
| 1. Bežični Svrdlo – Philips Voditelj | 6. Traka Divizor |
| 2. Vijak Vozač - Philips Voditelj | 7. Ručni Rukavice |
| 3. Drvodjelac Četverkut | 8. Oko Zaštitnik |
| 4. 8' Korak Ljestve | 9. Vodonepropusni bistri silikon |
| 5. Razina – 3 stoplo. | 10. Čekić ili gumeni čekić |

HU A szükséges szerszámok

- | | |
|---------------------------------------|-----------------------------|
| 1. Vezeték nélküli fúró – csillagfejű | 6. Mérőszalag |
| 2. Csavarhúzó – csillagfejű | 7. Kesztyűk |
| 3. Ácsderékszög | 8. Szemvédő |
| 4. 8-fokú létra | 9. Vízálló, tiszta szilikon |
| 5. Vízszintmérő. | 10. Hammer vagy gumi sisak |

SV Verktyg du kommer att behöva

- | | |
|--------------------------------------|-------------------------------|
| 1. Sladdlös bormaskin - Philips borr | 6. Måttband |
| 2. Skruvmejsel - krysshuvud | 7. Verktygshandskar |
| 3. Vinkelhake | 8. Ögonskydd |
| 4. 8-fots stege | 9. Vattentät Klar Silikon |
| 5. vattenmått - 3fot. | 10. Hammer eller Gummihammare |

IT Gli Attrezzi di cui Avrai Bisogno

- | | |
|--|--------------------------------------|
| 1. Trapano senza fili – Punta a stella | 6. Metro a Nastro |
| 2. Cacciavite – Punta a stella | 7. Guanti |
| 3. Squadra metallica | 8. Protezione per gli occhi |
| 4. Scala ad 8 pioli | 9. Silicone trasparente impermeabile |
| 5. Livello – 3 piedi | 10. Martello o martello di gomma |

PL Potrzebne narzędzia

- | | |
|---|--------------------------------------|
| 1. Bezprzewodowa wkrętarka – krzyżakowa | 6. Taśma miernicza |
| 2. Śrubokręt krzyżakowy | 7. Rękawice ochronne |
| 3. Kałownik stolarski | 8. Okulary ochronne |
| 4. 8' Drabina składana | 9. Wodoodporny przezroczysty silikon |
| 5. Poziomica – 91,4 cm | 10. Młotek lub młotek gumowy |

RO Instrumentele de care aveți nevoie

- | | |
|-------------------------------------|------------------------------------|
| 1. Șurubelniță – cap Philips | 6. Ruletă de măsurat |
| 2. Mașină de găurit – cap Philips | 7. Mănuși de protecție |
| 3. Echer de dulgherie | 8. Protecție pentru ochi |
| 4. Scară cu trepte de 8' (20.32 cm) | 9. Silicon transparent impermeabil |
| 5. Nivel - 3ft. | 10. Ciocan sau ciocan din cauciuc |

BG Инструменти, които ще ви трябват

- | | |
|---|------------------------------|
| 1. Безжична бормашина - с глава Philips | 6. Рулетка |
| 2. Отвертка – с глава Philips | 7. Ръкавици |
| 3. Прав ъгъл | 8. Маска за очите |
| 4. Стълба – 20 см (8') | 9. Водоустойчив ясен силикон |
| 5. Нивелир – 1 м (3ft). | 10. Чук или гумен чук |

TR İhtiyaç duyacağınız aletler

- | | |
|------------------------------------|-------------------------------|
| 1. Kablosuz Matkap- Philips Başlık | 6. Mezura |
| 2. Tornavida-Philips Başlık | 7. Eldiven |
| 3. Marangoz gönyesi | 8. Göz Koruyucu |
| 4. 8 Basamaklı Merdiven | 9. Su geçirmez Şeffaf Silikon |
| 5. Seviye- 91,5 cm. | 10. Çekiç veya Kauçuk tokmak |

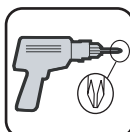

1



2



3



4



5

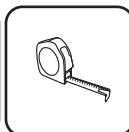

6



7



8

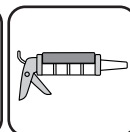

9

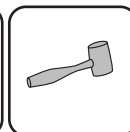

10

EN Parts List

FR Liste des pièces

DE Teilleiste

ES La Lista de Partes

PT Lista de Peças

NL Onderdelenlijst

CS Seznam součástí

SK Zoznam častí

SL Seznam delov

HR Dijelovi Lists

HU Alkatrésztlista

SV Komponentlista

IT Lista delle varie parti

PL Lista części

RO Lista elementelor componente

BG Списък на частите

TR Parça Listesi

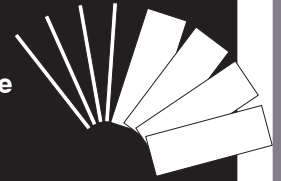

- EN** 1. Check all parts prior to installation.
2. Before starting installation, please refer to Safety & Precautions.

- FR** 1. Vérifier toutes les pièces avant l'installation.
2. Avant de commencer l'installation, référez-vous svp à Sécurité et Précautions.

- DE** 1. Prüfen Sie alle Teile vor der Montage.
2. Lesen Sie vor dem Aufbau die Sicherheitsanweisungen.

- ES** 1. Verifique todo el despiece antes del montaje.
2. Antes de comenzar el montaje, consulte el apartado de seguridad y precauciones.

- PT** 1. Confirme todas as peças antes da instalação.
2. Antes de iniciar a instalação, cheque item "Segurança e Cuidados".

- NL** 1. Controleer vooraf of alle onderdelen aanwezig zijn.
2. Voordat u begint met installeren, verwijzing naar veiligheid voorschriften.

- CS** 1. Než začnete s montáží, zkontrolujte všechny součásti.
2. Před montáží si prosím přečtete Bezpečnost a bezpečnostní opatření.

- SK** 1. Skontrolujte všetky časti pred inštaláciou.
2. Skôr ako začnete s inštaláciou, prečítajte si Bezpečnosť a bezpečnostné opatrenia.

- SL** 1. Pred montažo preverite vse dele.
2. Pred začetkom namestitve, glejte VARNOST & VARNOSTNI UKREPI.

- HR** 1. Provjera svih dijelova prije instalacije.
2. Prije nego Vi počete instalaciju, molim vas pogledajte Sigurnost i mjere opreza

- HU** 1. Ellenőrizzen minden alkatrészt az összeszerelés megkezdése előtt.
2. Az összeszerelés megkezdése előtt kérjük vegye figyelembe a biztonsági utasításokat.

- SV** 1. Kolla alla delar före installationen.
2. innan man startar installationen ska man läsa igenom säkerhet & försiktighetsåtgärder.

- IT** 1. Controlla tutte le parti prima dell'installazione.
2. Prima di incominciare con l'istallazione, per favore leggi attentamente I punti illustrati nel paragrafo Sicurezza ed Installazione.

- PL** 1. Sprawdź wszystkie części zanim przystąpisz do montażu.
2. Przed rozpoczęciem instalacji należy przeczytać rozdział Bezpieczeństwo i środki ostrożności.

- RO** 1. Verificați toate părțile componente înainte de instalare.
2. Înainte de a începe asamblarea, consultați capitolul. Măsuri de siguranță și protecție.

- BG** 1. Проверете всички части преди монтажа.
2. Преди започване на монтажа, моля разгледайте Безопасност и Защита.

- TR** 1. Kurulumdan önce tüm parçaları kontrol ediniz.
2. Montaja başlamadan önce lütfen Güvenlik ve Önlemler kısmına bakınız.





	FCLR	1
	FCRR	1
	CMR	5
	CCR	2
	VRF01	2
	VRF02	4
	VRF03	4
	VRF04	1
	VRA06	2
	VRA07	2
	VJA01	2
	VCF01	1
	VCB03	2
	VCB04	2
	VRA12	2
	VRA13	1
	VRF06	2
	VRF07	2
	VRF08	4
	VRF09	6
	WPE1	8
	RPF1	3
	RPF2	3
	FPF1	1
	FPF2	1
	DLE	1
	DRE	1
	BPF1	1
	BPF2	1
	BPF3	1

	FDCL	1
	FDCR	1
	FCC	4
	FMC	5
	CCF	4
	RJ	4
	PPG	40
	PPGL	2
	PIN	40
	PINL	2
	CMF	2
	L	1
	R	1
	LH↑	2
	RH↑	2
	BPS	22
	BP	42
	S1	97
	S2	18
	S5	22
	S7	44
	SGC1	20
	F1	8
	S6	8
	PW	20

-  **1** → # 10-33
- 2** → # 34-45
- 3** → # 46-50
- 4** → # 51-53

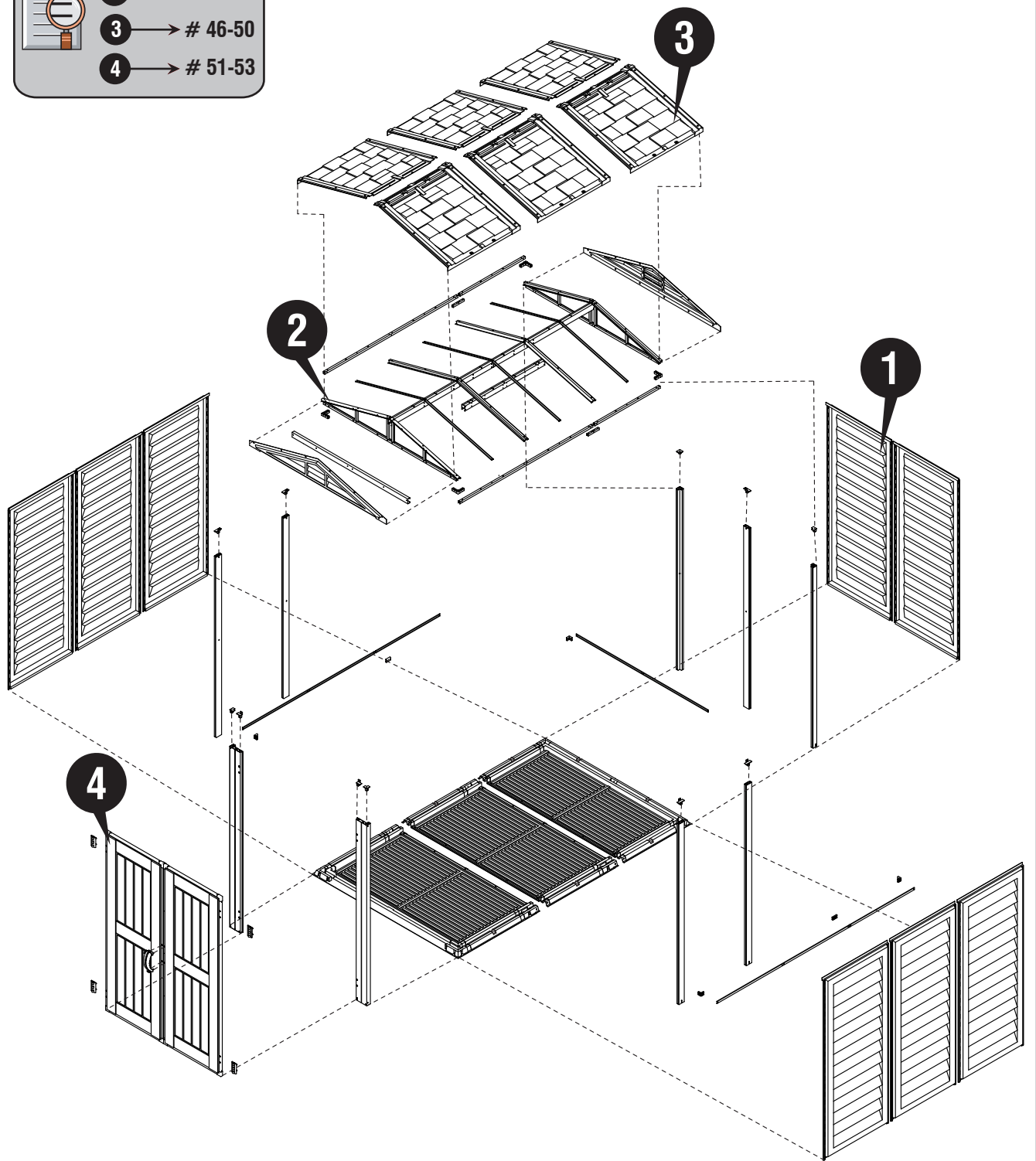



EN Walls & Columns	CS Zdi a kolumny	IT Pareti & Colonne
FR Murs et colonnes	SK Steny a stĺpy	PL Ściany i Kolumny
DE Wände und Säulen	SL Stene in stebri	RO Pereți și stâlpi
ES Columnas y paredes	HR Zidovi i Kolumne	BG Стени & Колони
PT Paredes e Colunas	HU Falak és oszlopok	TR Duvarlar & Sütunlar
NL Panelen en stijlen	SV Väggar & Kolumner	

1

- EN** 1. Set the Torque limit of your Screw drill to #3 or #4 to ensure the Screws do not strip the Metal reinforcements.
2. It is important that these instructions are followed step by step.
3. Don't install under windy conditions.
4. All parts are clearly marked and care should be taken to use the correct one.
5. If you are building the shed against a wall, build it 2.5 ft. away then slide it in. (Only for Duramax foundation & Wooden foundation)

- FR** 1. Réglez la limite de couple de votre perceuse Vis à n # 3 ou n # 4 pour s'assurer que les vis ne supprime pas les renforts métalliques
2. Il est important que ces instructions soient suivies pas à pas.
3. Ne pas installer sous conditions de vent.
4. Toutes les pièces sont clairement identifiées et il convient de veiller à utiliser la bonne.
5. Si vous construisez le hangar contre un mur, le construire à un écart de 2,5 pi, puis le glisser. (ceci n'est applicable pour la Fondation Duramax Fondation en bois).

- DE** 1. Stellen Sie das Drehmoment Ihres Akkuschaubers auf Stufe 3 oder 4. Dies verhindert ein Überdrehen der Schrauben.
2. Diese Anleitung muss unbedingt Schritt für Schritt befolgt werden.
3. Die Montage nicht bei windigem Wetter vornehmen.
4. Alle Teile sind deutlich gekennzeichnet und es ist darauf zu achten, dass die richtige verwendet wird.
5. Wenn Sie den Schuppen an einer Wand bauen, bauen sie es 2,5 Fuß weg, dann schieben Sie es ein. (Nur für Duramax Fundament & Holzfundament)

- ES** 1. Establecer el límite de par de su taladro tornillo de # 3 y # 4 para que no traspasa los refuerzos metálicos
2. Es importante que estas instrucciones se sigan paso a paso.
3. No instale en días de mucho viento.
4. Recuerde que todas las piezas están marcadas para su correcto montaje.
5. Si usted está construyendo la caseta contra una pared, móntela a una distancia 2.5 pies (75cm) y una vez montada deslícela hacia la pared. (esto sólo es aplicable para la estructura de kit de suelo Duramax).

- PT** 1. Defina o limite de Torque de sua broca parafuso para # 3 ou # 4 para garantir que os parafusos não tira os reforços de metal.
2. É importante que estas instruções sejam seguidas passo a passo.
3. Não instale sob condições com forças ventanosas.
4. Todas as peças estão claramente marcadas e deve-se tomar cuidado para usar a correta.
5. Se você está construindo o galpão contra uma parede, construa-o a 2,5 pés de distância para então encostá-lo na mesma. (Apenas para o Duramax fundação e base de madeira)

- NL** 1. Stel de Torque limiet van uw Schroef boormachine op # 3 en # 4 om de schroeven zorgen niet strip de Metal versterkingen.
2. Het is belangrijk dat volgende instructies stap voor stap worden gerespecteerd.
3. Nooit de schuur installeren onder winderige omstandigheden.
4. Alle onderdelen zijn duidelijk gemarkeerd en er moet op worden gelet dat de juiste wordt gebruikt.
5. Als u het schuur tegen muur aan het bouwen bent, bouwt u maar de schuur op 70cm afstand en schuif die er tegen de muur aan. (Alleen voor Duramax foundation & Houten foundation)

- CS** 1. Nastavte mezní hodnotu točivého momentu vrtacího vrtáku na #3 nebo #4, abyste zajistili, že šrouby neztáhnou kovové výztuhy.
2. Je důležité aby jste tento návod sledovali krok za krokem.
3. Nemontujte při větrném počasí.
4. Všechny díly jsou jasně označeny a je třeba dbát na správnou funkci.
5. Pokud stavíte přístřešek proti zdi, postavte ji 70cm stranou a poté jí přisuňte. (Pouze pro Duramax založení a dřevěné základy)

- SK** 1. Nastavte limit krútiaceho momentu vrtacieho vrtáka na #3 alebo #4, aby ste zaistili, že skrutky nezaberajú kovové výztuhy.
2. Je nutné dodržiavať tieto inštrukcie krok za krokom.
3. Neinštalujte za veterných podmienok.
4. Všetky časti sú zreteľne označené a treba dbať na to, aby boli použité správne.
5. Ak budujete múru, postavte ju 2,5 stóp. preč, a potom ju zasunúť. (Len pre Duramax založenie a drevené základy)



- SL** 1.Za omejitev vrtilnega momenta vijahnega vijaka nastavite #3 ali #4, da zagotovite, da vijaki ne ojačitijo kovinskih ojačitev.
2.Pomembno je, da sledite opisanim navodilom korak za korakom.
3.Montaže ne izvijajte, kadar piha močen veter.
4.Vsi deli so jasno označeni in pazite na pravilno uporabo.
5.Če se gradi skladišče proti steni, ga graditi 2,5 ft. stran, nato pa ga potisnite v. (samo za Duramax temelj in leseno osnovo)

- HR** 1.Postavite granicu zakretnog momenta Vašeg vijčanog bušilica na #3 ili #4 kako biste osigurali da vijci ne skidaju metalna pojačanja.
2.To je važno da ovih instrukcije su slijedili korak po korak.
3.Nemojte instalirati pod vjetrovitim uvjetima.
4.Svi dijelovi su jasno označeni i treba voditi brigu o ispravnom korištenju.
5.Ako gradite proliveno zid, izgradite ga 2,5 m. daleko, a zatim ga gurnite. (Samo za Duramax zaklade i drveni temelja)

- HU** 1.Állítsa a csavarhúzó nyomatékhatárait #3 vagy #4-re, hogy a csavarok ne csavarják le a fém vasalatokat
2.Fontos, hogy az itt következő instrukciókat lépésről lépésre betartsa.
3.Szeles időben ne végezzen összeszerelést.
4.Minden alkatrész egyértelműen megjelölve, és gondoskodni kell a helyes használatáról.
5.Ha egy fészket építesz a falhoz, építsd meg 2,5 métert. távolítsa el, majd csúsztassa be. (Csak a Duramax Alapítvány és a Fa Alapítvány)

- SV** 1.Ställ in momentskruven på din skruvborr till #3 eller #4 för att säkerställa att skruvarna inte slår av metallförstärkningarna.
2.Det är viktigt att dessa instruktioner följs steg för steg.
3.Installera inte när det är blåsigt.
4.Alla delar är tydligt märkta och försiktighet bör vidtas för att använda rätt.
5.Om du bygger ett skjul mot en vägg, bygg det 2,5 ft. bort och skjut in den. (Endast för Duramax Foundation & Wooden stiftelse)

- IT** 1. Impostare il limite di coppia della fresa a vite a #3 o #4 per assicurare che le viti non striscia i rinforzi metallici
2.E' molto importante che queste istruzioni vengano seguite passo dopo passo.
3.Non installare in presenza di forte vento.
4.Tutte le parti sono chiaramente contrassegnate e occorre prestare attenzione per utilizzare quella corretta.
5.Se si sta costruendo il capannone contro un muro, costruirlo 2,5 ft. via, poi farlo scorrere in.
(Solo per Duramax Foundation e Fondazione di legno)

- PL** 1.Ustaw moc wkrętarki na #3 lub #4, aby upewnić się, że wkręty nie uszkodzą metalowych wzmocnień.
2.Bardzo ważne jest, by dokładnie stosować się do niniejszej instrukcji.
3.Nie należy montować w przypadku silnego wiatru.
4.Wszystkie części są wyraźnie oznaczone i należy zachować ostrożność, aby użyć właściwego.
5.Jeśli budujesz szopę przy ścianie, zbuduj ją 0,8 m dalej, a następnie wsuń. (Tylko dla fundamentów Duramax i fundamentów drewnianych)

- RO** 1.Setați limita de cuplu a burghiului dvs. de șurub la #3 sau #4 pentru a vă asigura că șuruburile nu lărgesc armăturile metalice.
2.Este importantă respectarea pas cu pas a acestor instrucțiuni.
3.Nu instalați dacă vântul atinge viteze mari.
4.Toate părțile sunt marcate în mod clar și trebuie să se țină seama de utilizarea celei corecte.
5.Dacă construiți vapoarașul pe perete, construiți-l la o distanță de 2,5 ft, apoi glisați-l. (Doar pentru fundația Duramax & fundație din lemn)

- BG** 1.Нагласете границата на въртящия момент на винтовата витла до #3 или #4, за да се уверите, че винтовете не изрязват металните подсилвания.
2.Важно е да следвате инструкциите стъпка по стъпка.
3.Да не се монтира при ветровито време.
4.Всички части са ясно маркирани и трябва да се внимава да се използва правилната.
5.Ако сте изградане на навес срещу стена, изградане то на 2,5 фута далеч след това го плъзнете инча (Само за Duramax фондация & дървени основи)

- TR** 1.Vidaların Metal takviyeleri soymadığından emin olmak için Vidalı matkabınızın Moment sınırını #3 veya #4'e ayarlayın.
2.Talimatların sırasıyla uygulanması önemlidir.
3.Rüzgarlı havalarda kurmayınız.
4.Tüm parçalar açıkça işaretlenmiştir ve doğru olanı kullanmak için özen gösterilmelidir.
5.Bir duvara kulübe bina varsa, o 2.5 ft kurmak. uzakta bir biçimde kaydırın. (Yalnızca Duramax vakıf ve Ahşap vakıf için)





- EN** DuraMax sheds are best installed on a raised level ground or a concrete foundation. If the shed is installed at ground level, ensure that there is proper water drainage sloping away from the shed so rain water does not pool and get inside the shed. For heavy rain areas, place the shed on a raised foundation which will have minimum outside dimensions of 102 3/8" x 70 7/8" (2600mm x 1800mm).
- FR** Les remises DuraMax sont mieux installées sur un sol surélevé ou sur une fondation en béton. Si le hangar est installé au niveau du sol, assurez-vous qu'il y a un drainage adéquat de l'eau en pente loin du hangar afin que l'eau de pluie ne s'accumule pas et ne pénètre pas dans le hangar. Pour les zones de fortes pluies, placez la remise sur une fondation surélevée qui aura des dimensions extérieures minimales de 102 3/8" x 70 7/8" (2600mm x 1800mm).
- DE** DuraMax-Schuppen werden am besten auf einem erhöhten Boden oder einem Betonfundament installiert. Wenn der Schuppen in Bodennähe installiert ist, stellen Sie sicher, dass eine ordnungsgemäße Wasserableitung vom Schuppen abfällt, damit sich kein Regenwasser ansammelt und in den Schuppen gelangt. Stellen Sie den Schuppen bei starkem Regen auf ein erhöhtes Fundament mit minimalen Außenabmessungen von 102 3/8" x 70 7/8" (2600mm x 1800mm).
- ES** Los cobertizos DuraMax se instalan mejor en un terreno nivelado o en una base de concreto. Si el cobertizo se instala a nivel del suelo, asegúrese de que haya un drenaje de agua adecuado en una pendiente que se aleje del cobertizo para que el agua de lluvia no se acumule y entre en el cobertizo. Para áreas de lluvia intensa, coloque el cobertizo sobre una base elevada que tendrá unas dimensiones exteriores mínimas de 102 3/8" x 70 7/8" (2600mm x 1800mm).
- PT** Os galpões DuraMax são mais bem instalados em um terreno elevado ou em uma fundação de concreto. Se o galpão for instalado no nível do solo, certifique-se de que haja drenagem de água adequada inclinando-se para longe do galpão para que a água da chuva não se acumule e entre no galpão. Para áreas de chuva forte, coloque o galpão em uma fundação elevada que terá dimensões externas mínimas de 102 3/8" x 70 7/8" (2600mm x 1800mm).
- NL** DuraMax-loodsen kunnen het beste worden geïnstalleerd op een verhoogde, vlakke ondergrond of op een betonnen fundering. Als de schuur op de begane grond wordt geïnstalleerd, zorg er dan voor dat er een goede waterafvoer is die wegloopt van de schuur, zodat regenwater niet in de schuur terechtkomt. Plaats bij zware regenval de schuur op een verhoogde fundering met een minimale buitenafmeting van 102 3/8" x 70 7/8" (2600mm x 1800mm).
- CS** Prístřešky DuraMax se nejlépe instalují na vyvýšený rovný podklad nebo na betonový základ. Pokud je bouda instalována na úrovni terénu, zajistěte, aby z ní byl dostatečný odtok vody, aby se srážková voda nehromadila a nedostala se do boudy. V oblastech se silným deštěm umístěte boudu na vyvýšený základ, který bude mít minimální vnější rozměry 102 3/8" x 70 7/8" (2600mm x 1800mm).
- SK** Búdy DuraMax sa najlepšie inštalujú na vyvýšený rovný podklad alebo na betónový základ. Ak je buda inštalovaná na úrovni terénu, zabezpečte dostatočný odtok vody od budy, aby sa dažďová voda nehromadila a nedostala sa do budy. V prípade silných dažďových plôch umiestnite buda na vyvýšený základ, ktorý bude mať minimálne vonkajšie rozmery 102 3/8" x 70 7/8" (2600mm x 1800mm).
- SL** DuraMax lope je najbolje namestiti na povišani tleh ali betonski podlagi. Če je lopa nameščena na tleh, poskrbite, da bo odtok vode pravilno nagnjen stran od lope, da se deževnica ne bo združila in vstopila v lopo. Za območja z močnim dežjem postavite lopo na dvignjen temelj, ki bo imel najmanjše zunanje mere 102 3/8" x 70 7/8" (2600mm x 1800mm).
- HR** DuraMax šupe najbolje je instalirati na povišenom tlu ili betonskom temelju. Ako je šupa postavljena u razini tla, pobrinite se da postoji odgovarajuća odvodnja vode koja se kosi od šupe kako se kišnica ne bi udružila i ušla u šupu. Za područja s jakim kišom, postavite šupu na povišeni temelj koji će imati minimalne vanjske dimenzije od 102 3/8" x 70 7/8" (2600mm x 1800mm).
- HU** A DuraMax fészereket a legjobban egy magasra emelt talajra vagy egy beton alapra lehet felszerelni. Ha a fészert talajszinten van felszerelve, győződjön meg arról, hogy megfelelő vízelvezetés van-e lejtve az istállótól, hogy az esővíz ne gyűljön össze és ne kerüljön a fészerbe. Heves esőzések esetén helyezze az istállót egy megemelt alapra, amelynek legkisebb külső méretei 102 3/8" x 70 7/8" (2600mm x 1800mm).
- SV** DuraMax-skjulet installeras bäst på en upplyft mark eller en betongfundament. Om skjulet installeras på marknivå, se till att det finns korrekt vattendränning lutande bort från skjulet så att regnvatten inte slår sig samman och kommer in i skjulet. För kraftiga regnområden, placera skjulet på ett upphöjt underlag som har minsta utvändiga dimensioner på 102 3/8" x 70 7/8" (2600mm x 1800mm).
- IT** I capannoni DuraMax si installano al meglio su un terreno rialzato o su una fondazione in calcestruzzo. Se il capannone è installato a livello del suolo, assicurarsi che vi sia un adeguato drenaggio dell'acqua in pendenza dal capannone in modo che l'acqua piovana non si accumuli e penetri all'interno del capannone. Per le aree con forti piogge, posizionare il capannone su una fondazione rialzata che avrà dimensioni esterne minime di 102 3/8" x 70 7/8" (2600mm x 1800mm).

PL Szopy DuraMax najlepiej instalować na podwyższonym poziomym gruncie lub na betonowym fundamencie. Jeśli szopa jest zainstalowana na poziomie gruntu, upewnij się, że jest odpowiedni odpływ wody, który spływa z dala od szopy, aby woda deszczowa nie gromadziła się i nie dostawała się do szopy. W przypadku intensywnych opadów deszczu należy umieścić szopę na podwyższonym fundamencie o minimalnych wymiarach zewnętrznych 102 3/8" x 70 7/8" (2600mm x 1800mm).

RO Depozitele DuraMax se instalează cel mai bine pe un teren înălțat sau pe o fundație din beton. Dacă magazia este instalată la nivelul solului, asigurați-vă că există o scurgere adecvată a apei înclinată de la magazie, astfel încât apa de ploaie să nu se strângă și să pătrundă în interiorul magaziei. Pentru zonele cu ploi abundente, așezați magazia pe o fundație ridicată, care va avea dimensiuni exterioare minime de 102 3/8" x 70 7/8" (2600mm x 1800mm).

BG Бараките DuraMax се инсталират най-добре на повдигнато ниво или върху бетонна основа. Ако навесът е монтиран на нивото на земята, уверете се, че има подходящ дренаж за вода, наклонен от навеса, така че дъждовната вода да не се обединява и да влиза вътре в навеса. За места с обилен дъжд поставете навеса върху повдигната основа, която ще има минимални външни размери от 102 3/8" x 70 7/8" (2600mm x 1800mm).

TR DuraMax hangarlar en iyi şekilde yükseltilmiş bir zemine veya beton bir temel üzerine kurulur. Hangar zemin seviyesinde kuruluysa, yağmur suyunun havuza girip kulübenin içine girmemesi için kulübeden uzağa doğru eğimli uygun su tahliyesi olduğundan emin olun. Şiddetli yağmurlu alanlar için, kulübeyi minimum 102 3/8" x 70 7/8" (2600mm x 1800mm) dış boyutları olan yükseltilmiş bir temel üzerine yerleştirin.

EN Parts needed

FR Pièces nécessaires

DE Benötigte Teile

ES Piezas necesarias

PT Peças Necessárias

NL Onderdelen nodig

CS Potřebné součásti

SK Potrebné časti

SL Dele, ki jih boste potrebovali

HR Dijelovi potreban

HU Szükséges részek

SV Delar som behövs

IT Parti occorrenti

PL Niezbędne elementy

RO Elementele componente necesare

BG Необходими части

TR Gerekli parçalar

VCF01	1	BPF3	1
VCB03	2	BP	18
VCB04	2	CCF	4
FCRR	1	CMF	2
CMR	5	BPS	22
CCR	2	S1	13
FCLR	1	S2	6
WPE1↑	8	S5	22
BPF1	1		
BPF2	1		

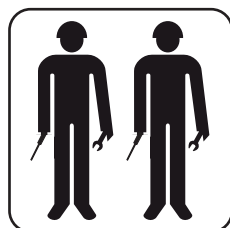

EN Two people needed.

FR Deux personnes nécessaires.

DE Zwei Personen benötigt.

ES Dos personas son necesarias para el montaje

PT Duas pessoas necessárias.

NL Er zijn twee mensen nodig.

CS Dva lidé potřebovali.

SK Dvaja ľudia potrebovali.

SL Potrebovali sta dve osebi.

HR Potrebne su dvije osobe.

HU Két emberre volt szükség.

SV Två personer behövde.

IT Sono necessarie due persone.

PL Potrzebne są dwie osoby.

RO Au nevoie de doi oameni.

BG Нужни са двама души.

TR İki kişiye ihtiyaç vardı.

1

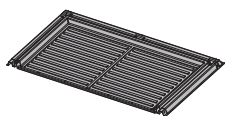

BPF2 (x1)

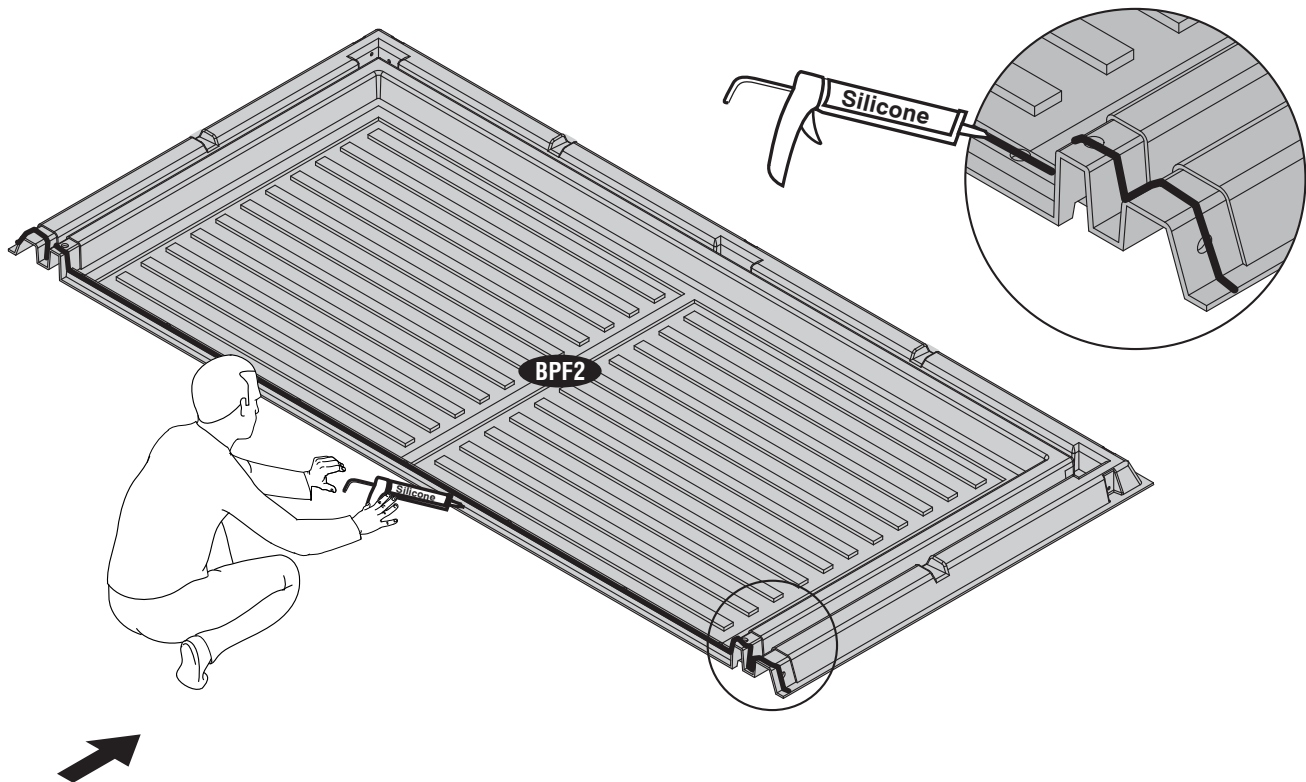
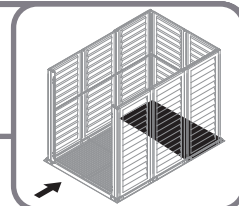

- EN Apply Silicone on the floor overlapping area (Silicone not included).
- FR Appliquez du silicone sur la zone de recouvrement du sol (silicone non inclus).
- DE Tragen Sie Silikon auf den Bodenüberlappungsbereich auf (Silikon nicht im Lieferumfang enthalten).
- ES Tragen Sie Silikon auf den Bodenüberlappungsbereich auf (Silikon nicht im Lieferumfang enthalten).
- PT Aplique Silicone na área de sobreposição do piso (Silicone não incluído).
- NL Breng siliconen aan op het overlappende gedeelte van de vloer (siliconen niet inbegrepen).
- CS Silikon naneste na překrývající se podlahu (silikon není součástí balení).
- SK Silikón naneste na prekrývajúcu sa plochu podlahy (silikón nie je súčasťou dodávky).
- SL Nanesite silikon na tla, ki se prekrivajo (Silikon ni priložen).
- HR Nanesite podlogu prekrivanja Silikon (Silikon nije uključen).
- HU Vigyen fel szilikonot az átfedő padlóra (a szilikon nem tartozék).
- SV Applicera silikon på golvetts överlappande område (silikon ingår inte).
- IT Applicare silicone sull'area di sovrapposizione del pavimento (silicone non incluso).
- PL Nałóż silikon na obszar nakładania się podłogi (nie zawiera silikonu).
- RO Aplicați silicon pe podea suprapusă (silicon nu este inclus).
- BG Нанесете силикон върху припокриващата се област (Силиконът не е включен).
- TR Zemin örtüşen alana Silikon uygulayın (Silikon dahil değildir).

2



BPF3 (x1)



BP (x9)

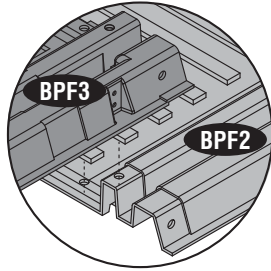
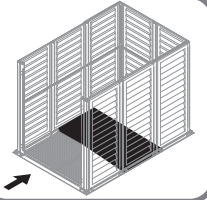

1

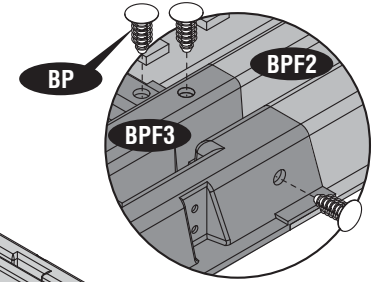

2

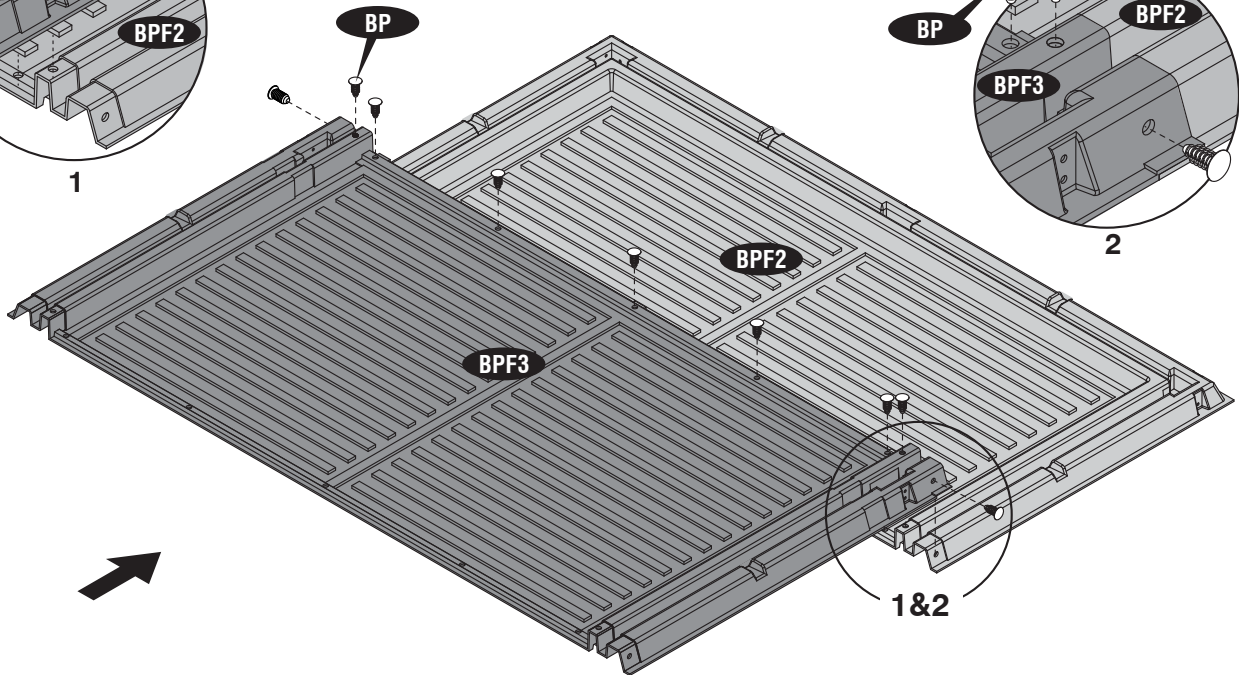

1&2



EN Use Same color Plugs(BP).

FR Utilisez les bouchons de même couleur (BP).

DE Verwenden Sie die gleichen Farbstopfen (BP).

ES Utilice tapones del mismo color (BP).

PT Use os plugues da mesma cor (BP).

NL Gebruik pluggen in dezelfde kleur (BP).

CS Použijte zástrčky stejné barvy (BP).

SK Použite zástrčky rovnakej farby (BP).

SL Uporabite iste barvne vtiče (BP).

HR Upotrijebite utikače iste boje (BP).

HU Használjon azonos színű dugókat (BP).

SV Använd samma färgpluggar (BP).

IT Utilizzare spine dello stesso colore (BP).

PL Użyj wtyczek tego samego koloru (BP).

RO Folosiți fișe de aceeași culoare (BP).

BG Използвайте едни и същи цветни щепсели (BP).

TR Aynı renkteki Fişleri (BP) kullanın.

3

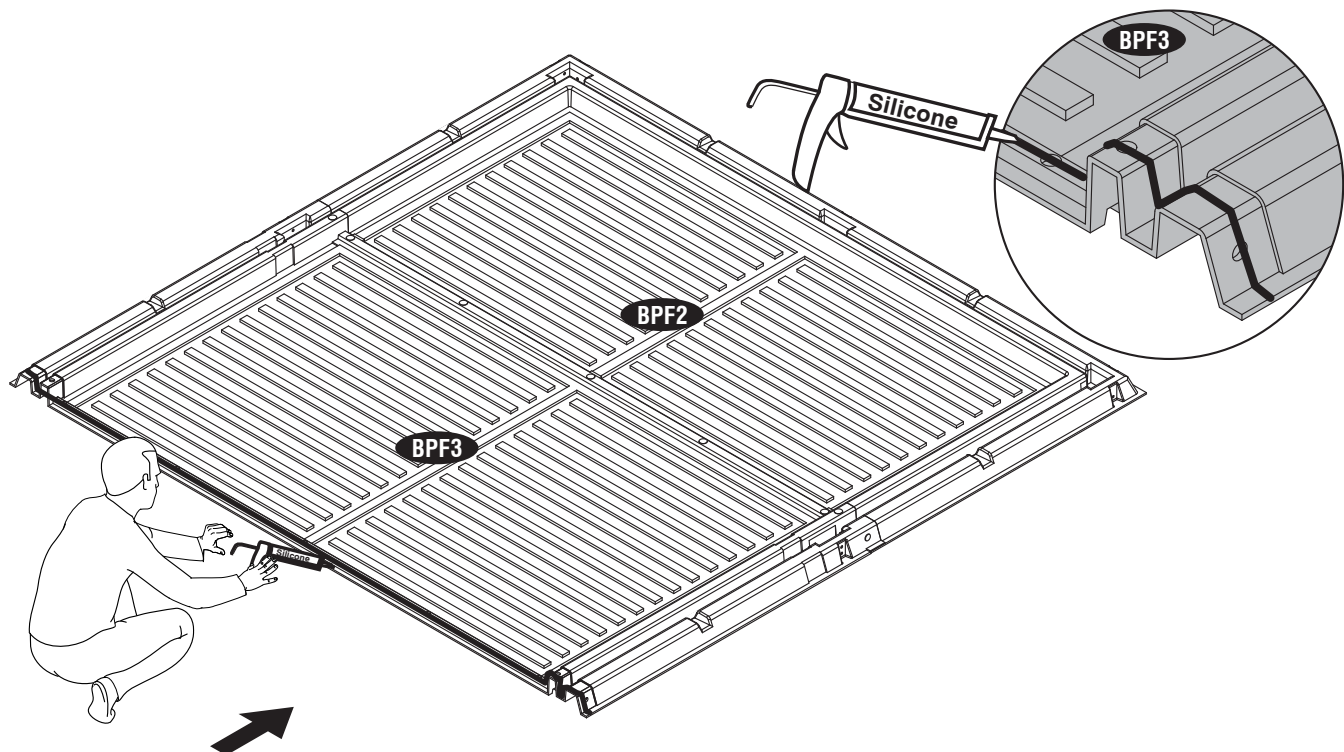
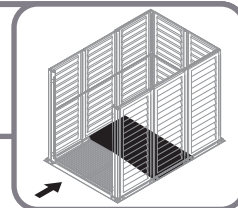

- EN Apply Silicone on the floor overlapping area (Silicone not included).
- FR Appliquez du silicone sur la zone de recouvrement du sol (silicone non inclus).
- DE Tragen Sie Silikon auf den Bodenüberlappungsbereich auf (Silikon nicht im Lieferumfang enthalten).
- ES Tragen Sie Silikon auf den Bodenüberlappungsbereich auf (Silikon nicht im Lieferumfang enthalten).
- PT Aplique Silicone na área de sobreposição do piso (Silicone não incluído).
- NL Breng siliconen aan op het overlappende gedeelte van de vloer (siliconen niet inbegrepen).
- CS Silikon naneste na překrývající se podlahu (silikon není součástí balení).
- SK Silikón naneste na prekrývajúcu sa plochu podlahy (silikón nie je súčasťou dodávky).
- SL Nanesite silikon na tla, ki se prekrivajo (Silikon ni priložen).
- HR Nanesite podlogu prekrivanja Silikon (Silikon nije uključen).
- HU Vigyen fel szilikonot az átfedő padlóra (a szilikon nem tartozék).
- SV Applicera silikon på golvet's överlappande område (silikon ingår inte).
- IT Applicare silicone sull'area di sovrapposizione del pavimento (silicone non incluso).
- PL Nałóż silikon na obszar nakładania się podłogi (nie zawiera silikonu).
- RO Aplicați silicon pe podea suprapusă (silicon nu este inclus).
- BG Нанесете силикон върху припокриващата се област (Силиконът не е включен).
- TR Zemin örtüşen alana Silikon uygulayın (Silikon dahil değildir).

4



BPF1 (x1)



BP (x9)

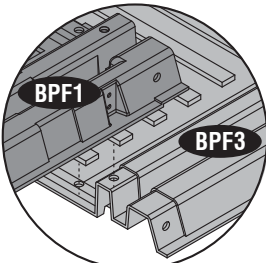
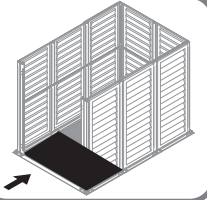

1

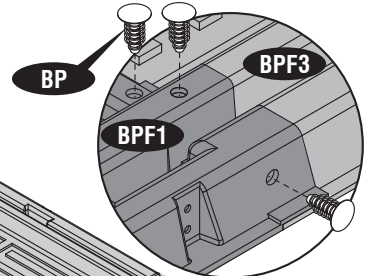

2

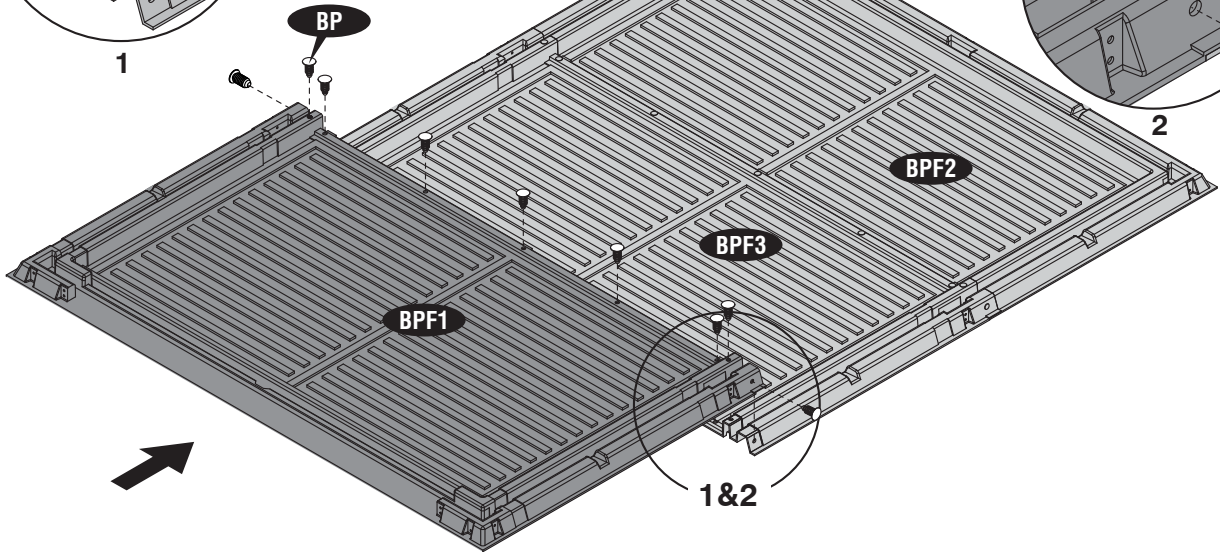

1&2



EN Use Same color Plugs(BP).

FR Utilisez les bouchons de même couleur (BP).

DE Verwenden Sie die gleichen Farbstopfen (BP).

ES Utilice tapones del mismo color (BP).

PT Use os plugues da mesma cor (BP).

NL Gebruik pluggen in dezelfde kleur (BP).

CS Použijte zástrčky stejné barvy (BP).

SK Použite zástrčky rovnakej farby (BP).

SL Uporabite iste barvne vtiče (BP).

HR Upotrijebite utikače iste boje (BP).

HU Használjon azonos színű dugókat (BP).

SV Använd samma färgpluggar (BP).

IT Utilizzare spine dello stesso colore (BP).

PL Użyj wtyczek tego samego koloru (BP).

RO Folosiți fișe de aceeași culoare (BP).

BG Използвайте едни и същи цветни щепсели (BP).

TR Aynı renkteki Fişleri (BP) kullanın.

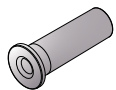

BPS (x22)

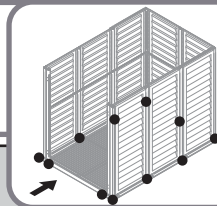

- EN** Insert the Sleeves (BPS) into all holes of the Base Pallet as shown in fig.
- FR** Insérez les manchons (BPS) dans tous les trous de la palette de base comme indiqué sur la fig.
- DE** Setzen Sie die Hülsen (BPS) in alle Löcher der Basispalette ein, wie in Abb.
- ES** Inserte las mangas (BPS) en todos los orificios de la plataforma base como se muestra en la fig.
- PT** Insira as mangas (BPS) em todos os orifícios da paleta base, conforme mostrado na fig.
- NL** Steek de hoezen (BPS) in alle gaten van de basispallet zoals getoond in afb.
- CS** Vložte rukávy (BPS) do všech otvorů základní palety, jak je znázorněno na obr.
- SK** Vložte rukávy (BPS) do všetkých otvorov základnej palety, ako je znázornené na obr.
- SL** Vstavite rokave (BPS) v vse luknje osnovne palete, kot je prikazano na sl.
- HR** Umetnite rukave (BPS) u sve rupe osnovne palete kao što je prikazano na sl.
- HU** Helyezze be a hüvelyeket (BPS) az alaplapp minden lyukába, ahogy az ábra mutatja.
- SV** För in hylsorna (BPS) i alla hål på baspallen som visas i fig.
- IT** Inserire le Maniche (BPS) in tutti i fori del Base Pallet come mostrato in fig.
- PL** Włóż rękawy (BPS) do wszystkich otworów palety podstawowej, jak pokazano na rys.
- RO** Introduceți manșoanele (BPS) în toate găurile paletului de bază așa cum se arată în fig.
- BG** Поставете втулките (BPS) във всички отвори на основния палет, както е показано на фиг.
- TR** Manşonları (BPS) Şekil 2'de gösterildiği gibi Taban Paletinin tüm deliklerine yerleştirin.

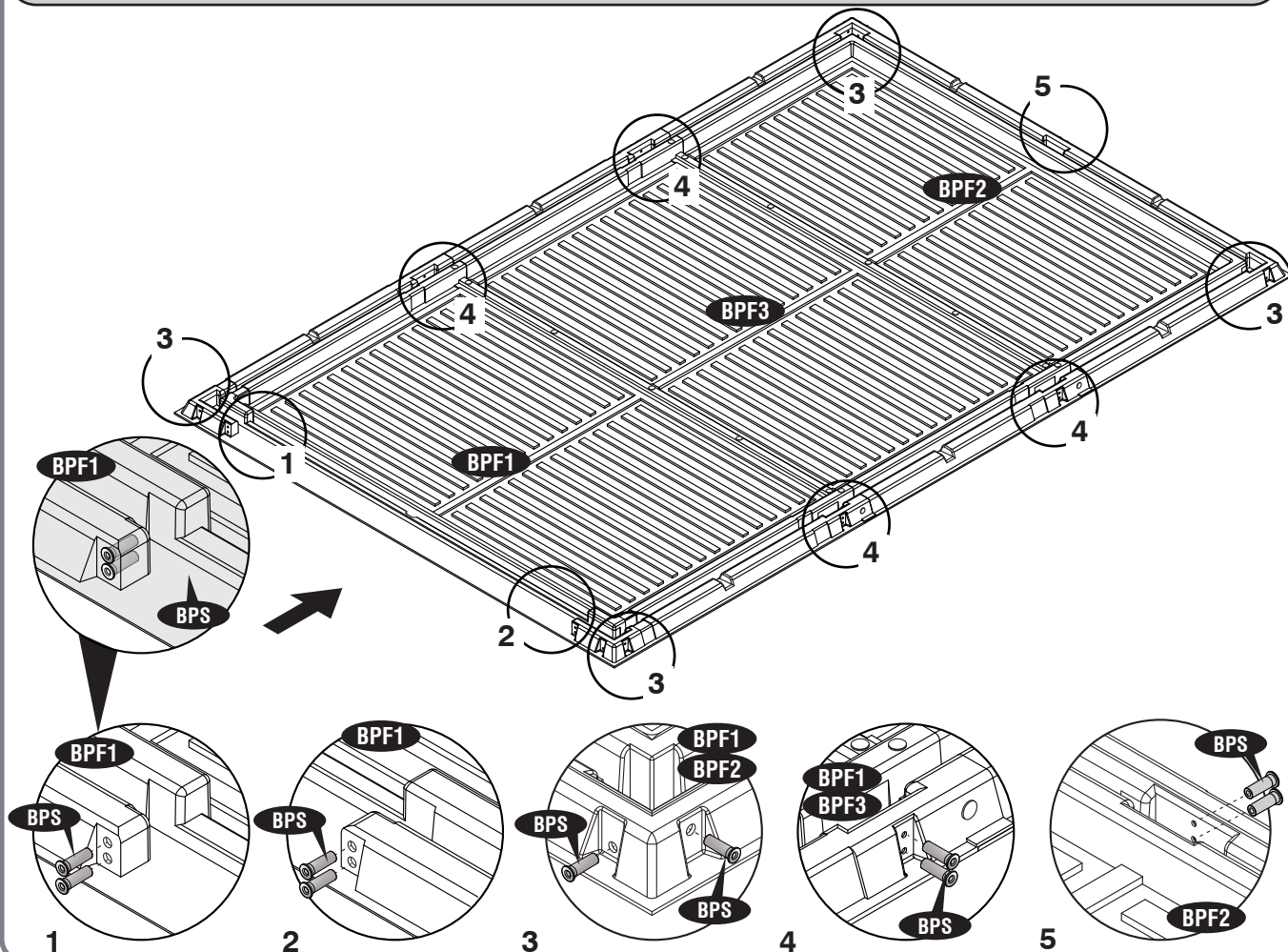

- EN Column & Panel Assembly method
- FR Colonne et méthode de montage panneau
- DE Montageverfahren für Säulen und Paneele
- ES Columna y el método de montaje de Panel
- PT Método de montagem de colunas e painéis
- NL Kolom en paneelmontage methode
- CS Metoda sestavení sloupců a panelů
- SK Metóda zhromažďovania stĺpcov a panelov
- SL Metoda zbiranja stolpcev in plošč
- HR Metoda montaže stupaca i panela
- HU Az oszlop és a panel összeszerelési módszer
- SV Kolonn- och panelmonteringsmetod
- IT Metodo di assemblaggio di colonne e pannelli
- PL Metoda montażu kolumn i paneli
- RO Coloana & metoda de asamblare panou
- BG Метод за сглобяване на колони и панели
- TR Sütun ve Panel Montaj yöntemi



- EN Lock the panel into the column from top to bottom.
- FR Verrouiller le panneau dans la colonne de haut en bas.
- DE Verriegeln Sie das Panel von oben nach unten in die Säule.
- ES Trabe el panel en la columna de arriba a abajo.
- PT Método de montagem de colunas e painéis
- NL Kolom en paneelmontage methode.
- CS Metoda sestavení sloupců a panelů.
- SK Metóda zhromažďovania stĺpcov a panelov.
- SL Metoda zbiranja stolpcev in plošč.
- HR Metoda montaže stupaca i panela.
- HU Az oszlop és a panel összeszerelési módszer.
- SV Kolonn- och panelmonteringsmetod.
- IT Metodo di assemblaggio di colonne e pannelli.
- PL Zablockuj panel w kolumnie od góry do dołu.
- RO Coloana & metoda de asamblare panou.
- BG Метод за сглобяване на колони и панели.
- TR Sütun ve Panel Montaj yöntemi.

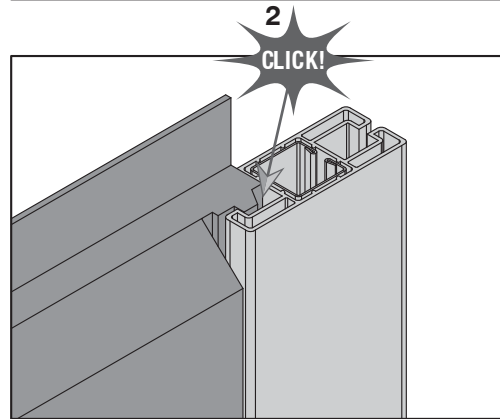
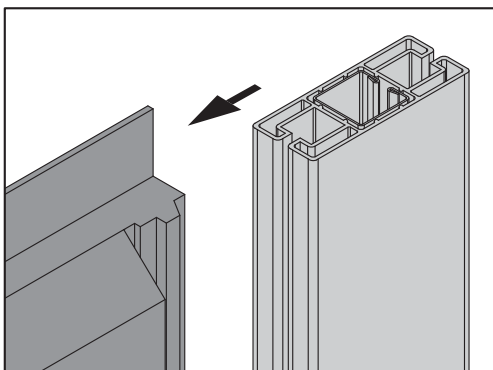
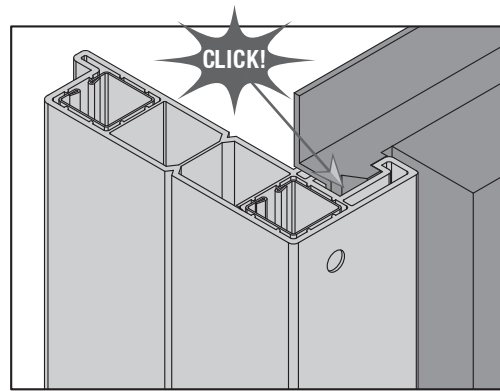
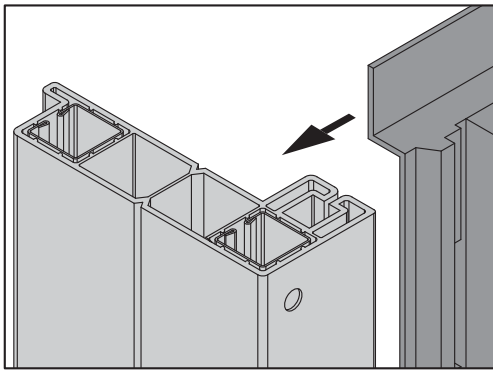
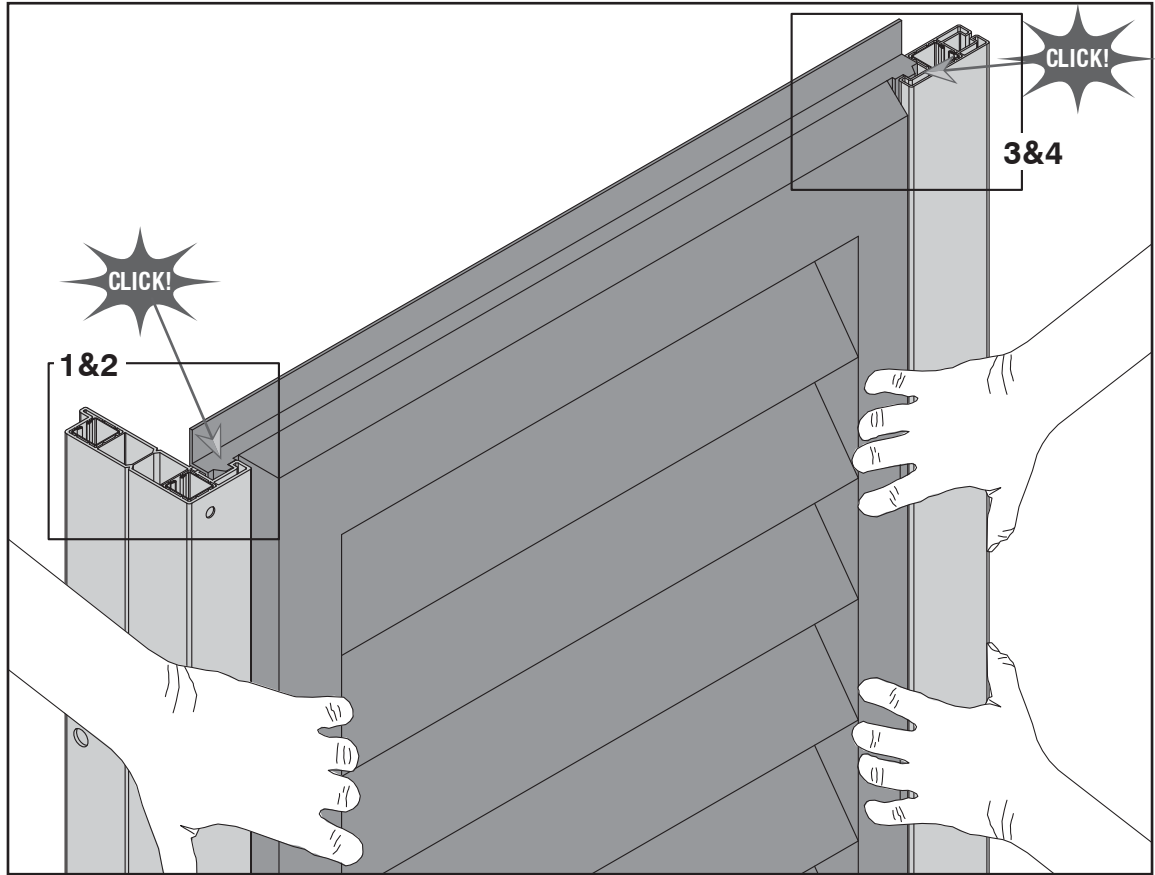

6

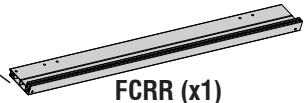

FCRR (x1)



S5 (x4)

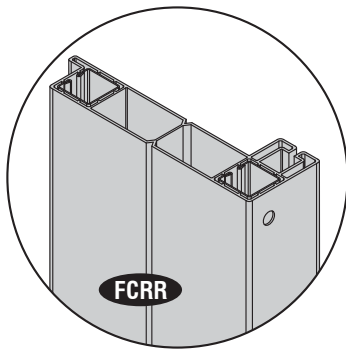
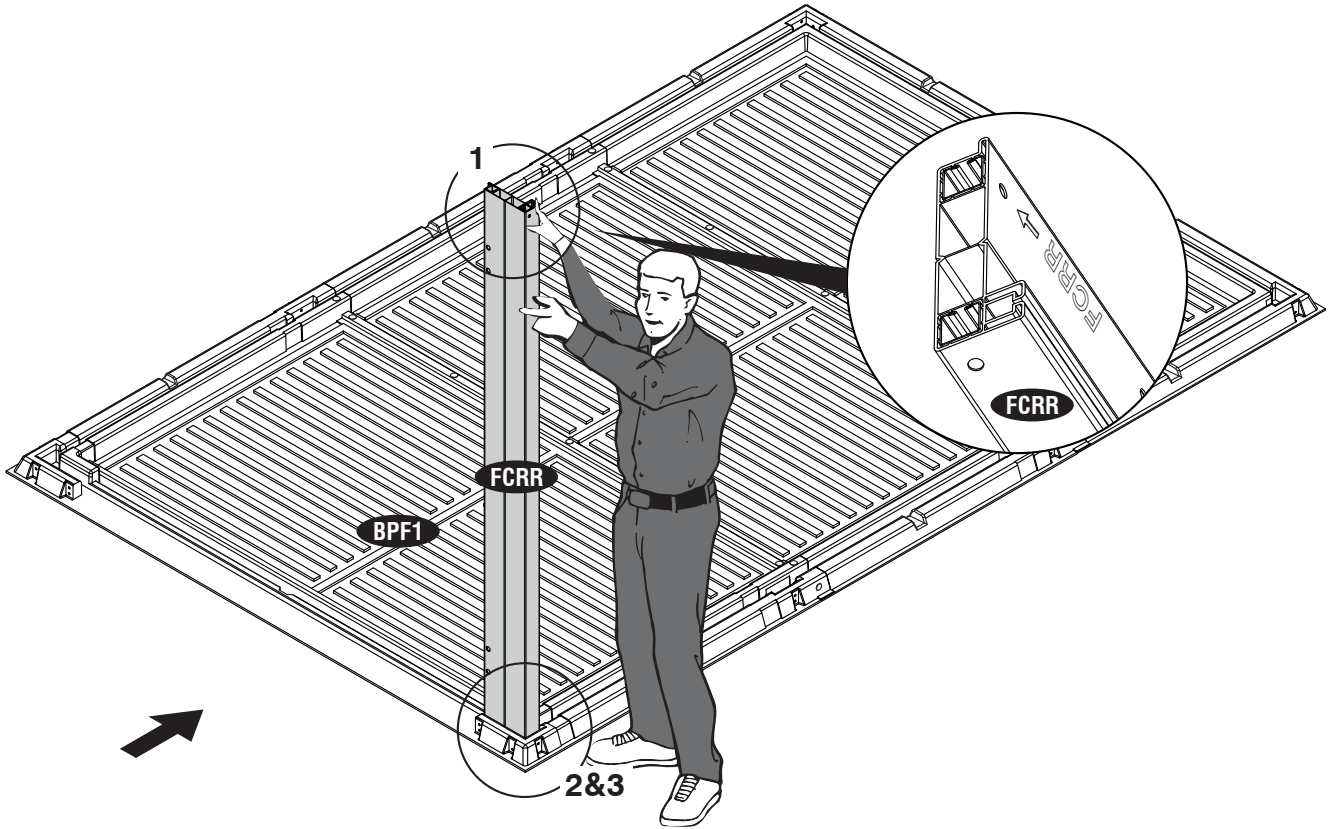
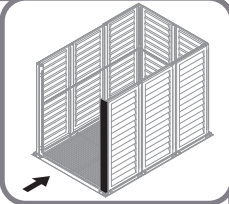

1

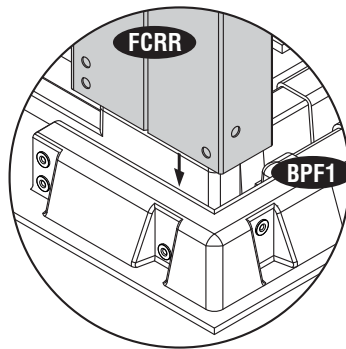

2

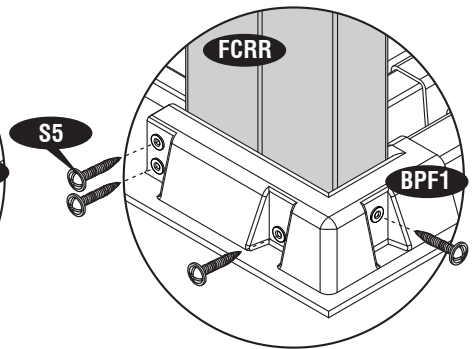

3

7

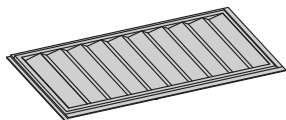

WPE1↑ (x1)

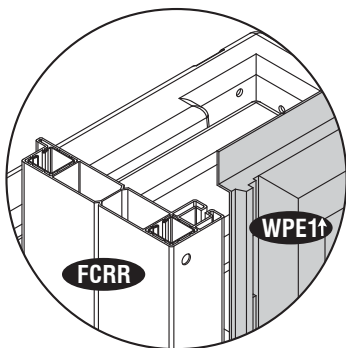
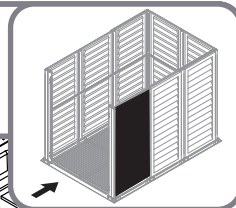

1

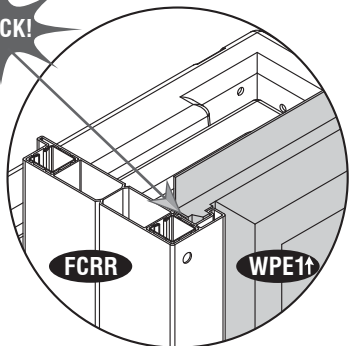

2

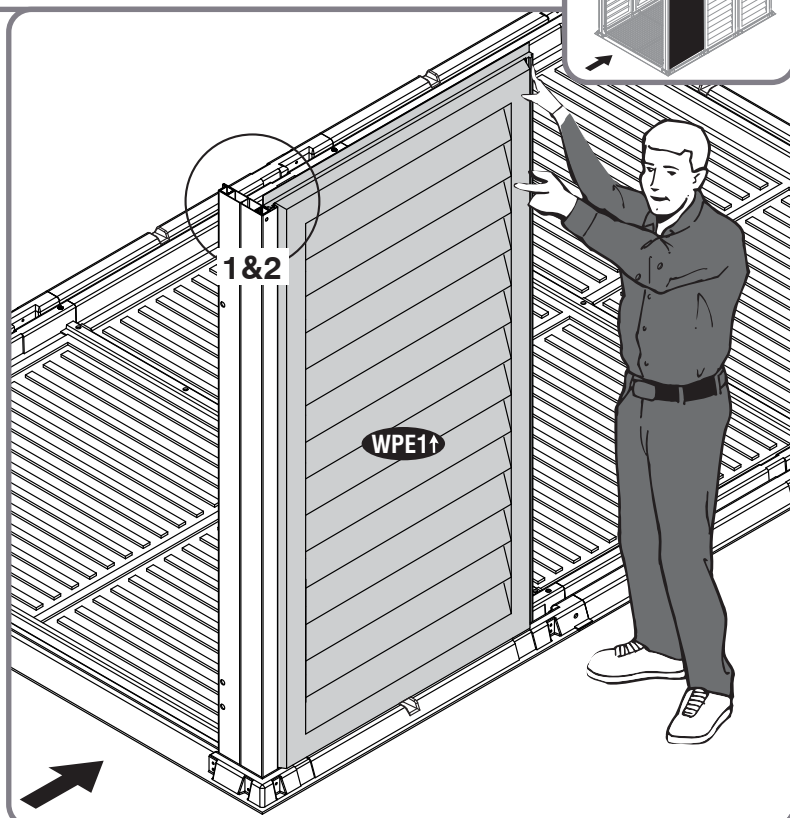

8



CMR (x1)



S5 (x2)

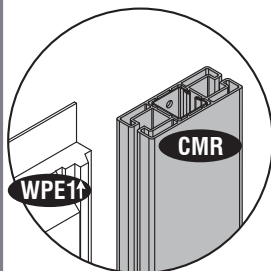
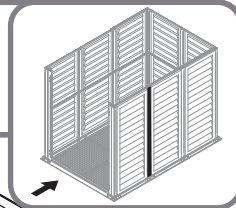

1

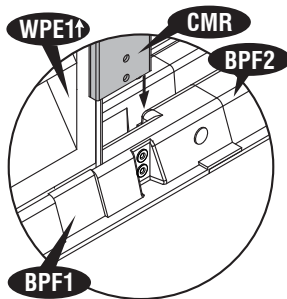

2

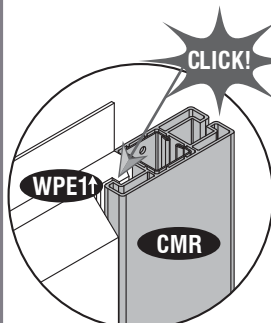

3

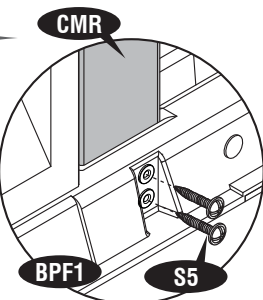

4

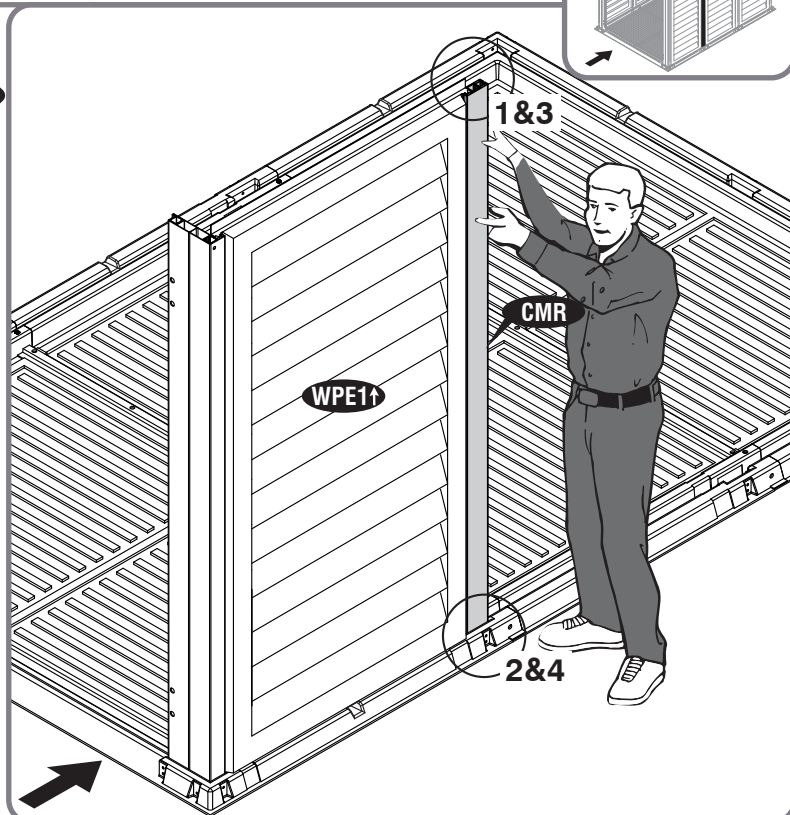

9

VCB03(x1)

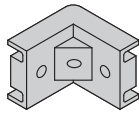

CCF (x1)



S2 (x1)



S1 (x2)

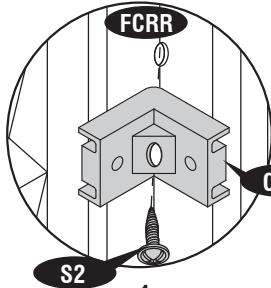
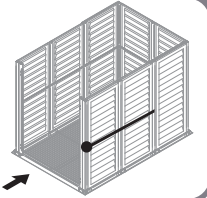

S2

1

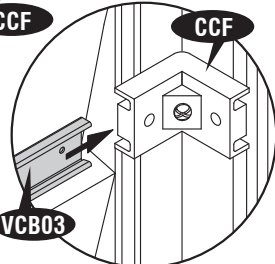

2

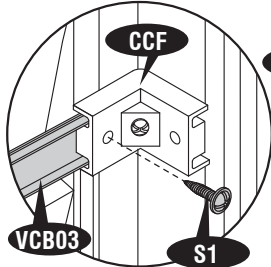

3

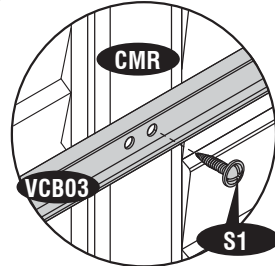

4

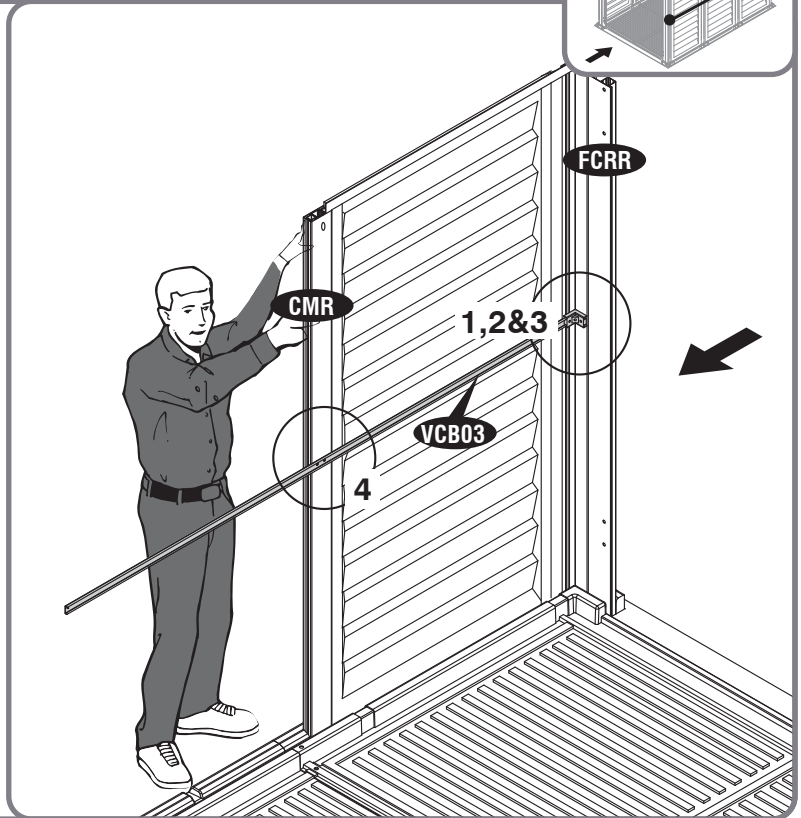

10

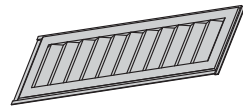

WPE1↑ (x1)

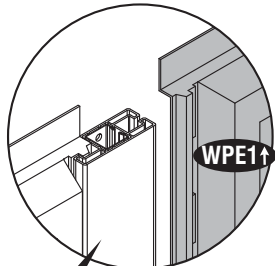
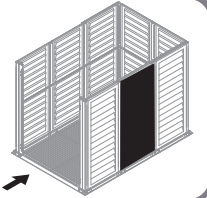

1

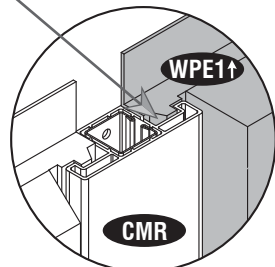

2

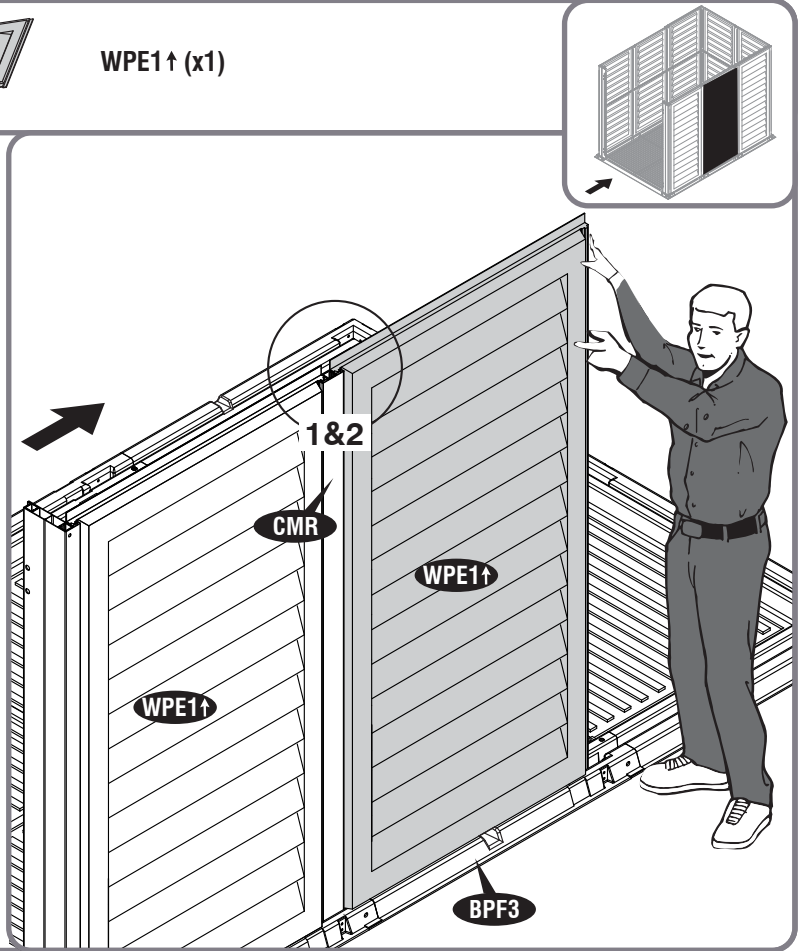

11

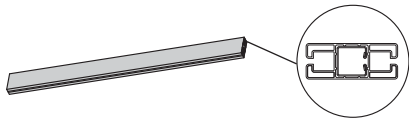

CMR (x1)



S5 (x2)

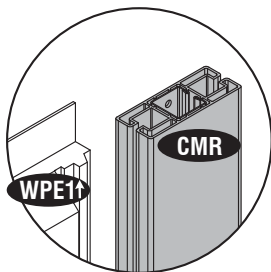
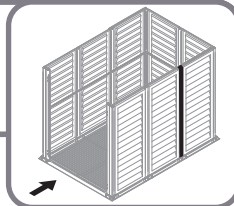

1

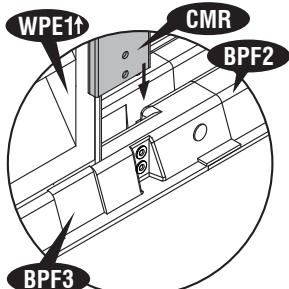

2

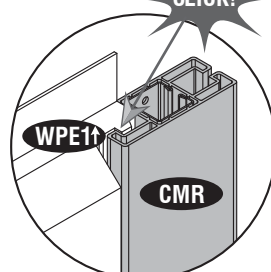

3

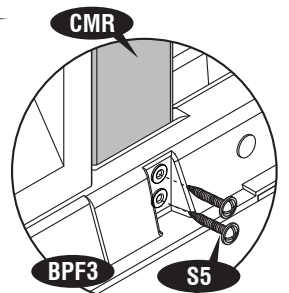

4

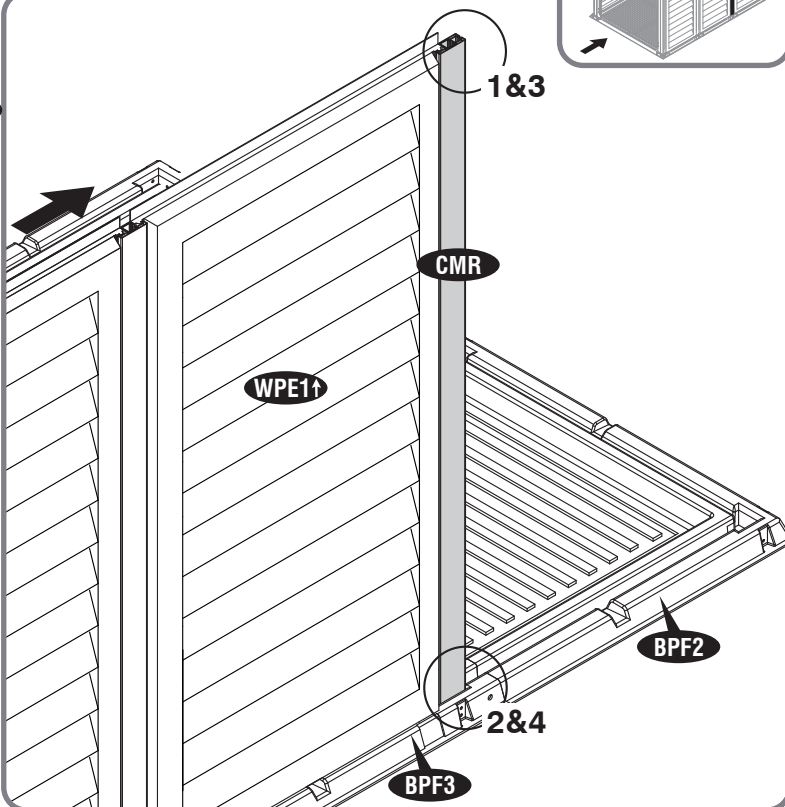

12

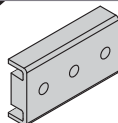

CMF (x1)



S2 (x1)



S1 (x1)

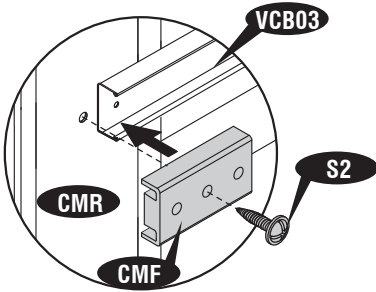
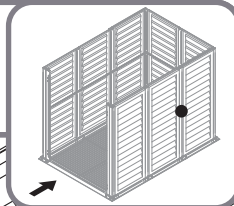

1

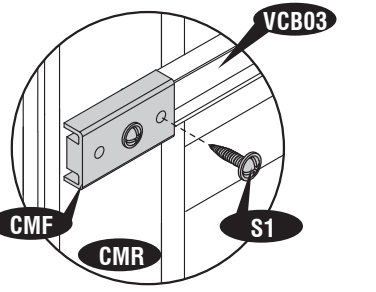

2

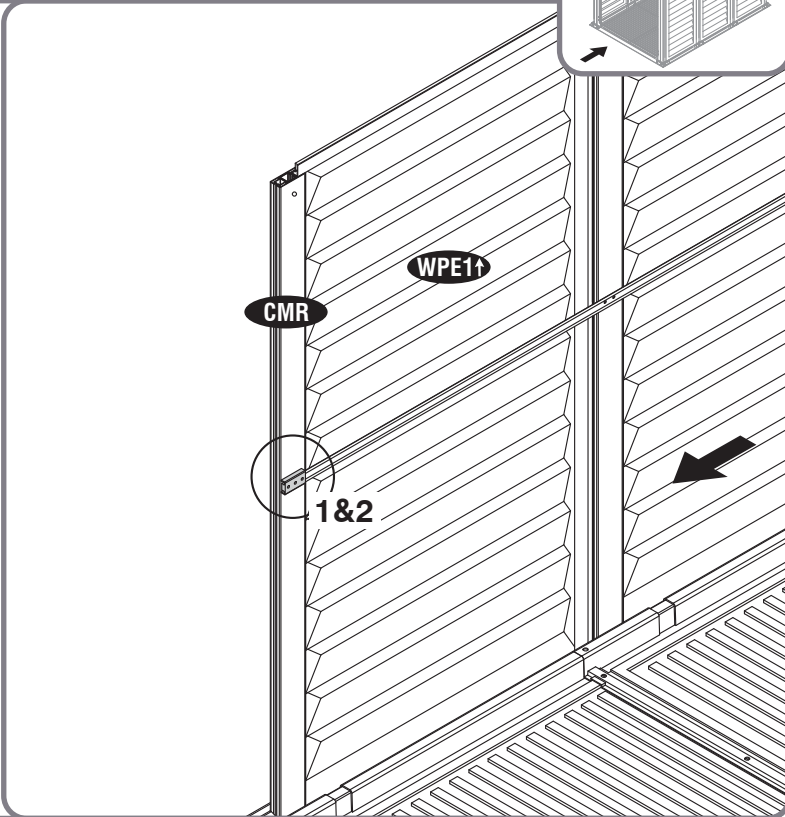

13

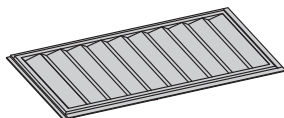

WPE1↑ (x1)

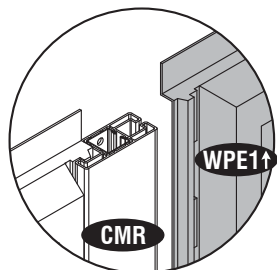
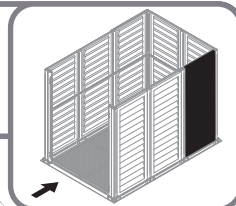

1

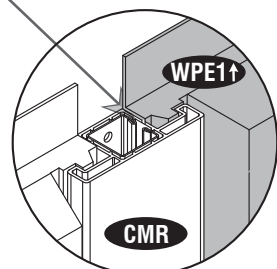

2

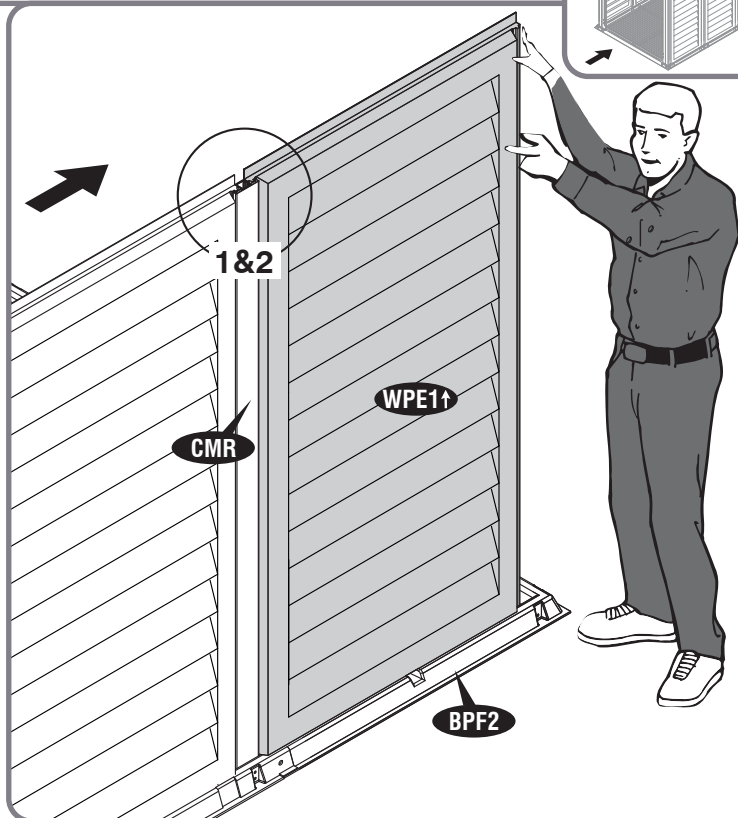

14

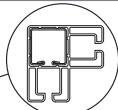
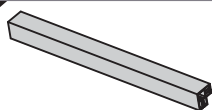

CCR (x1)



S5 (x2)

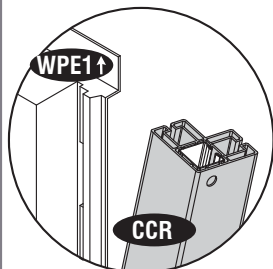
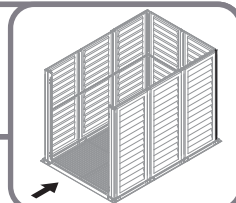

1

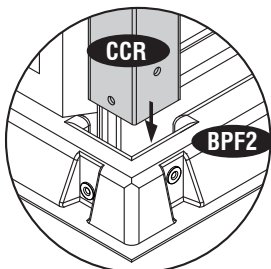

2

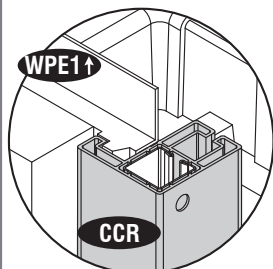

3

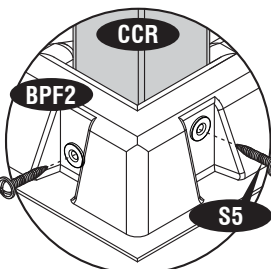

4

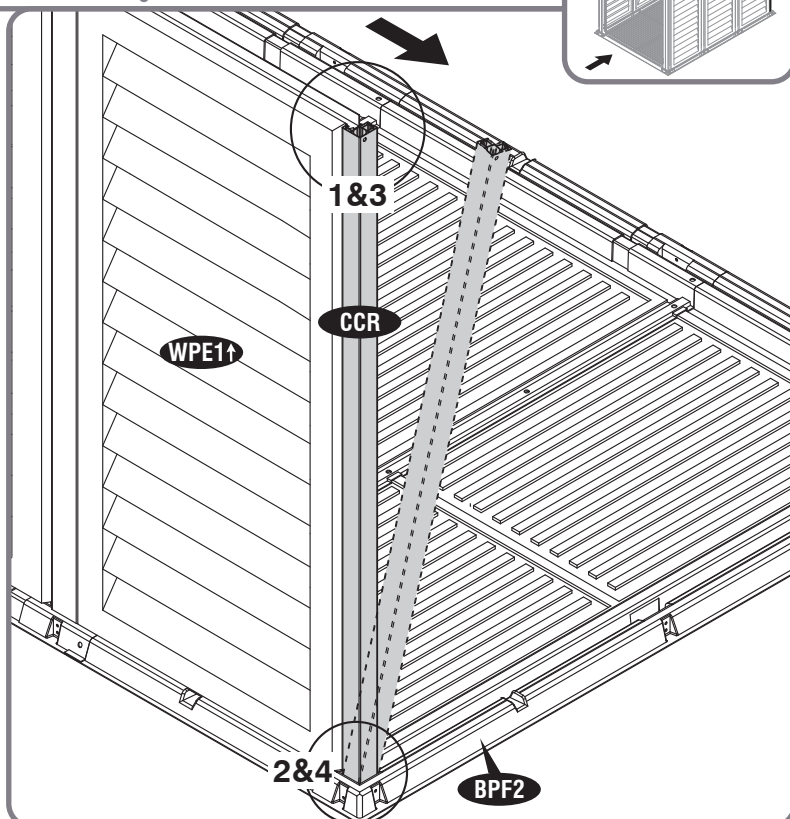

25

15

VCB04(x1)

CCF (x1)

S2 (x1)

S1 (x2)

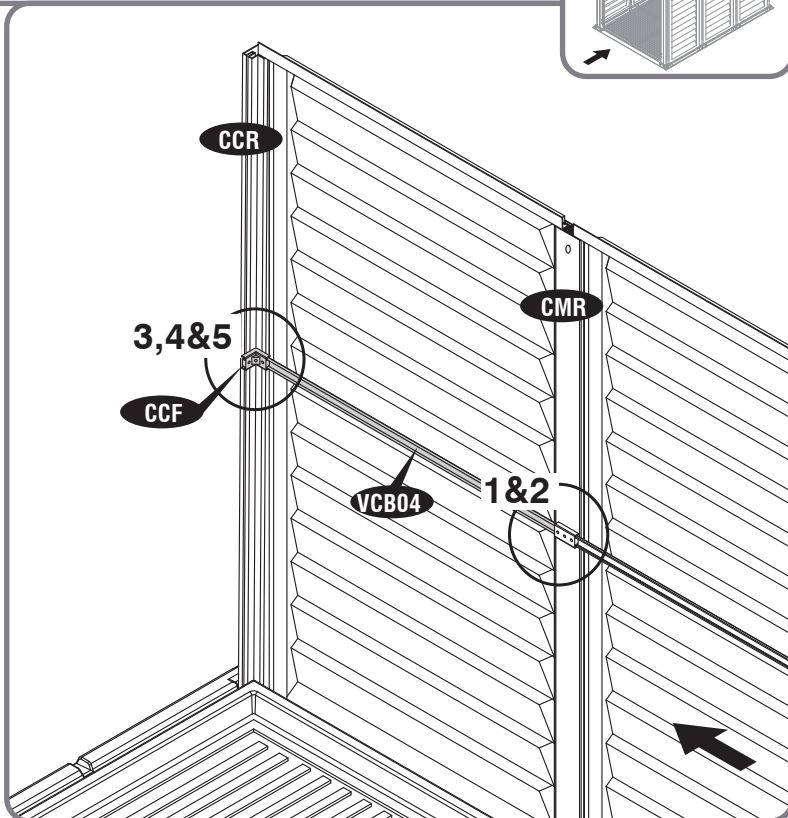
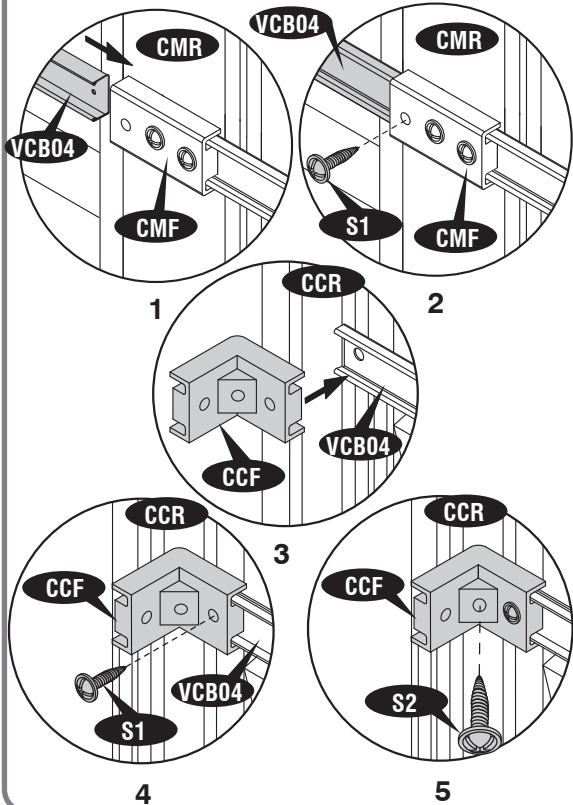

16

WPE1↑ (x1)

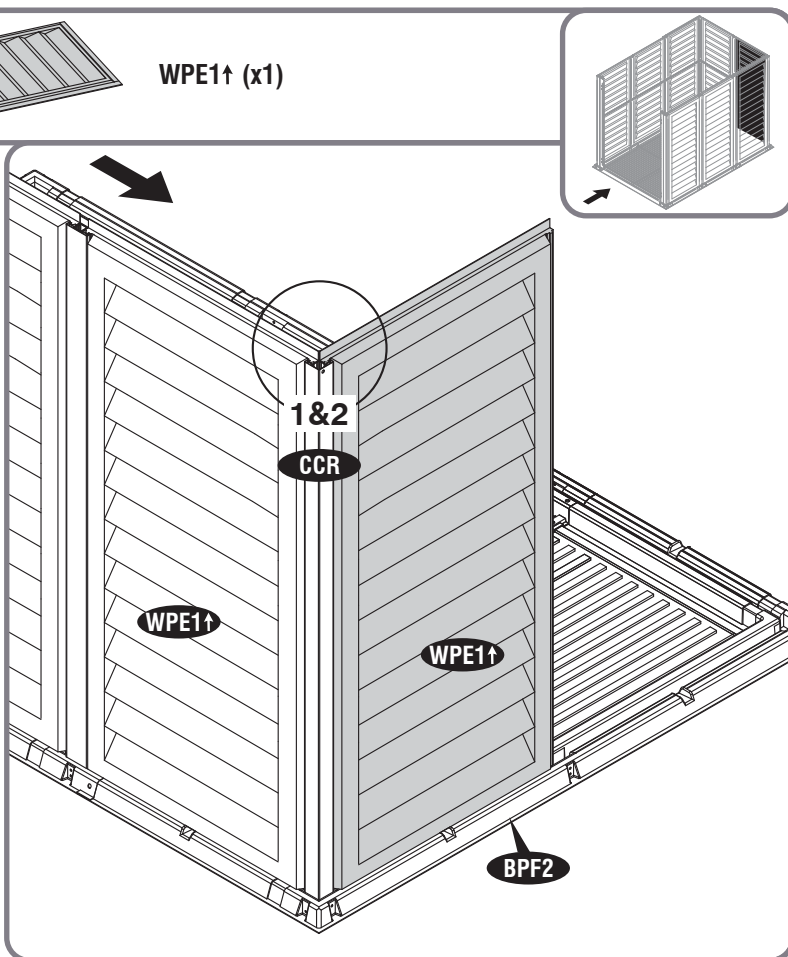
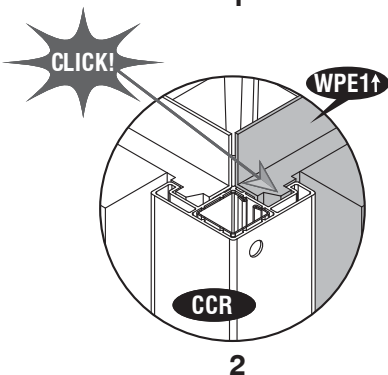
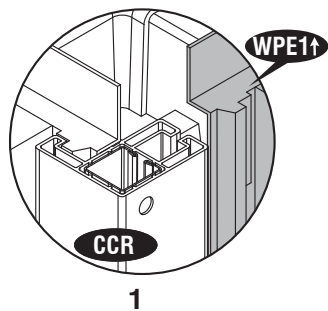

17

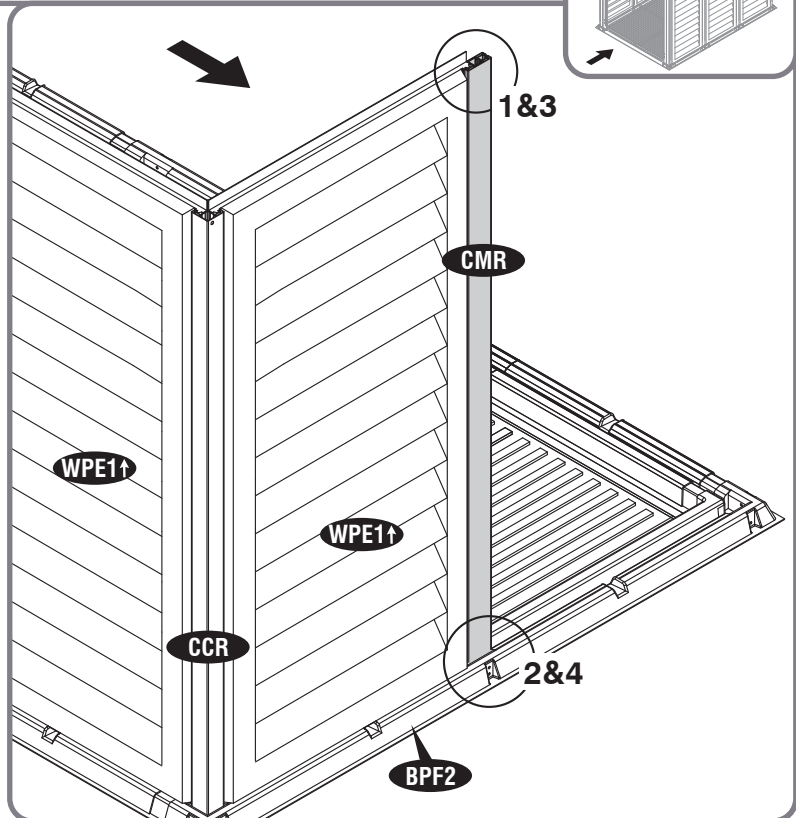
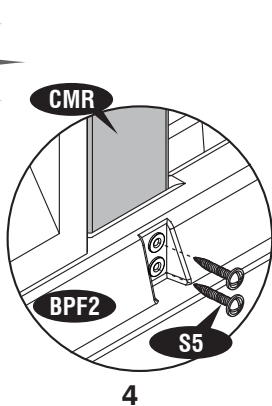
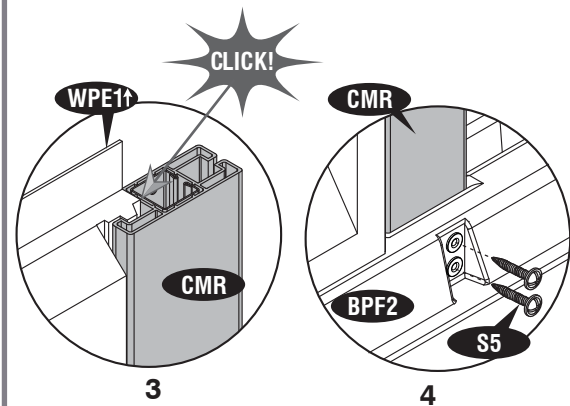
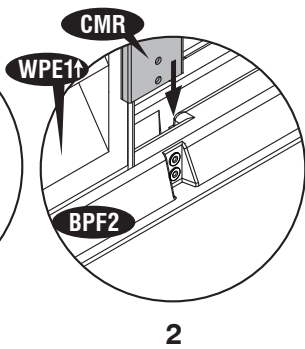
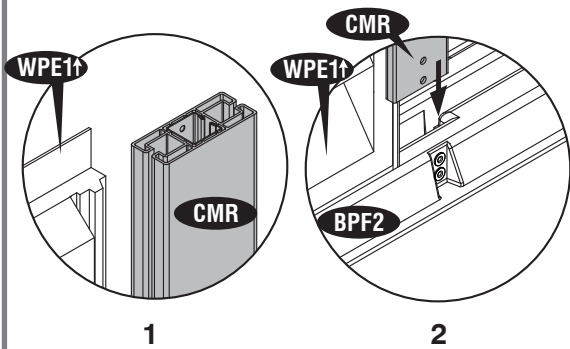
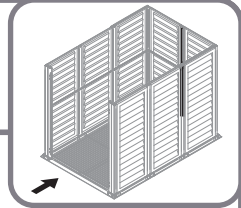
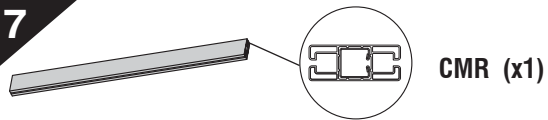

18

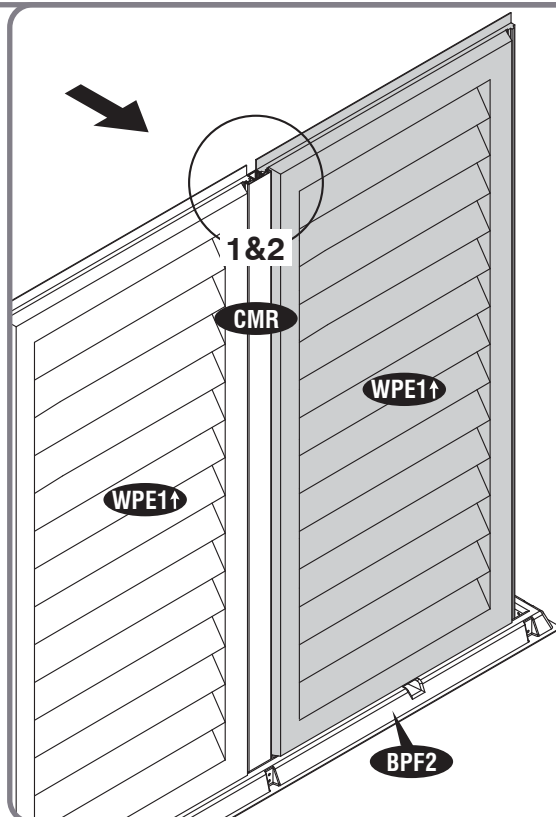
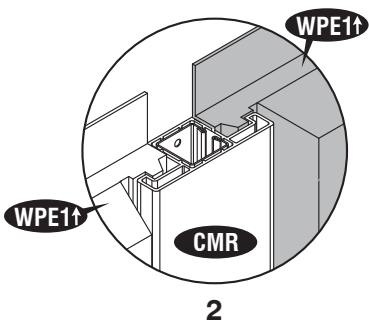
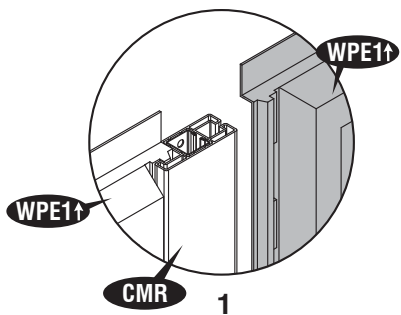
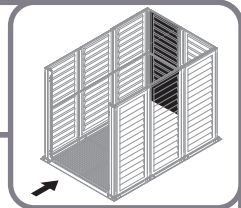
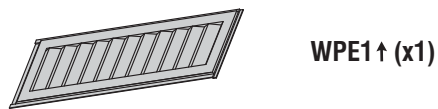

19

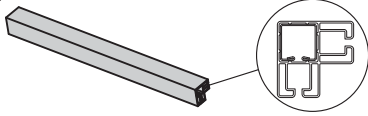

CCR (x1)



S5 (x2)

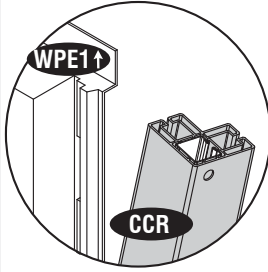
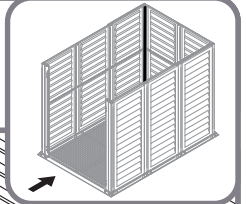

1

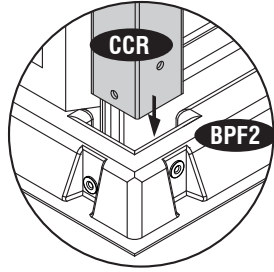

2

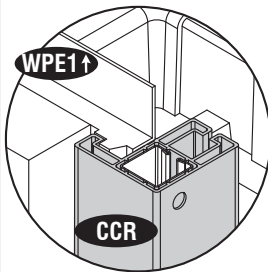

3

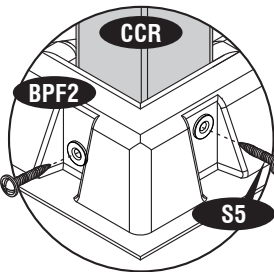

4

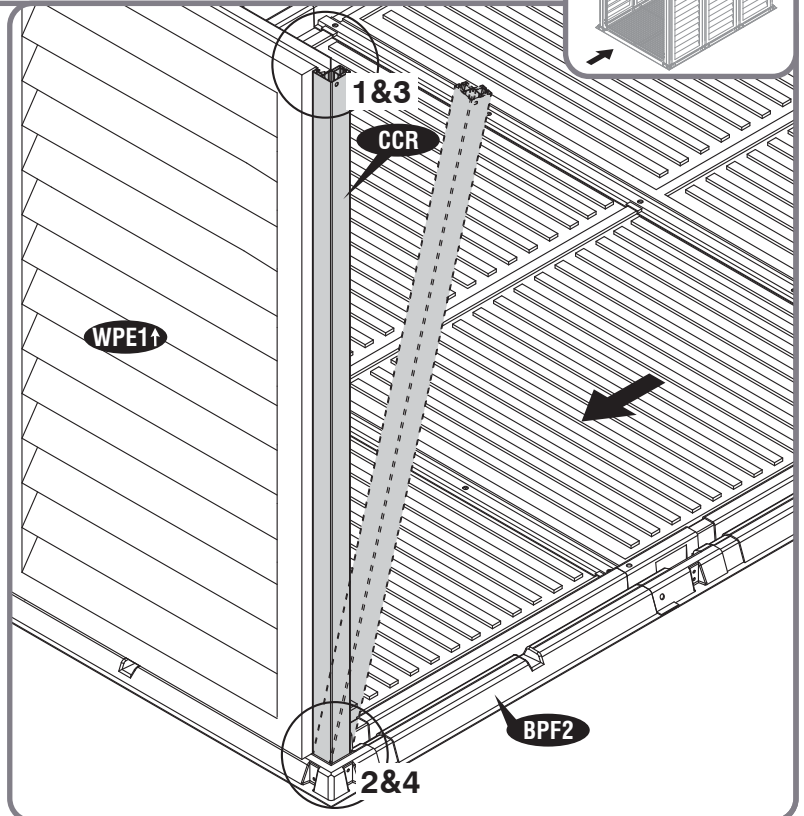

20



VCF01 (x1)



S1 (x2)

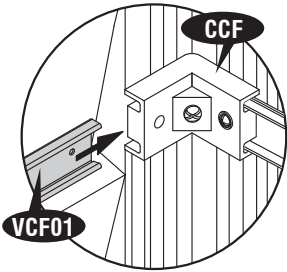
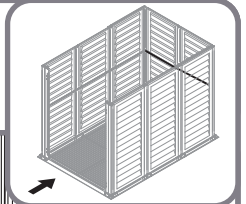

1

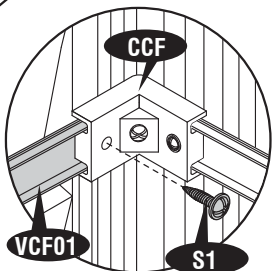

2

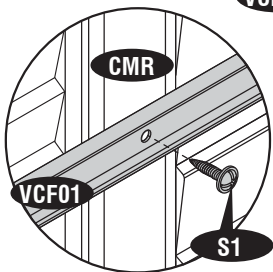

3

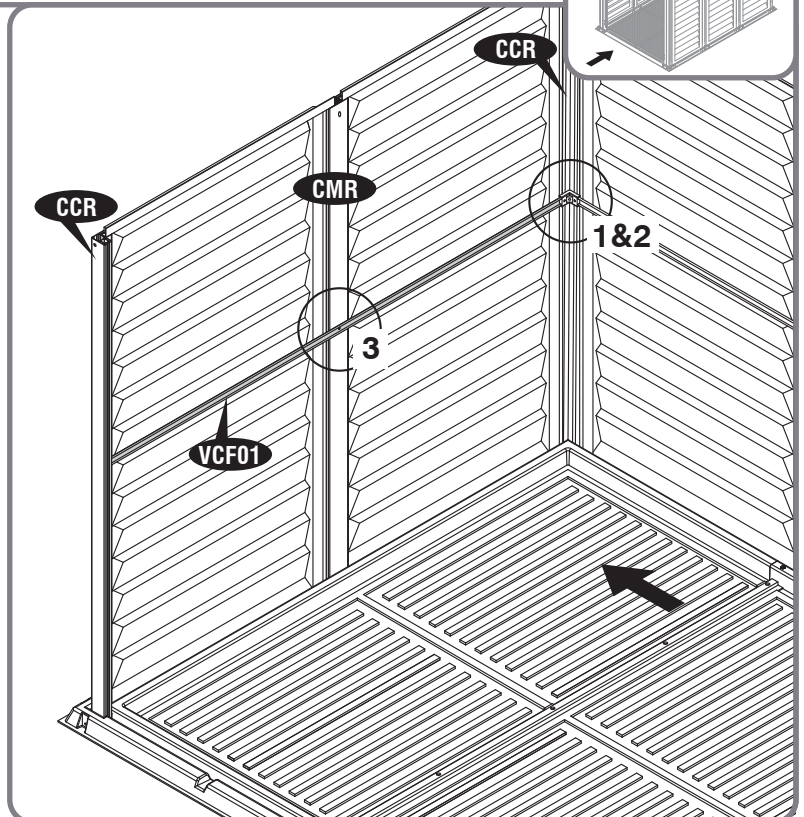

28

21

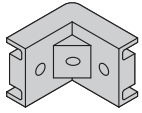

CCF (x1)



S2 (x1)



S1 (x1)

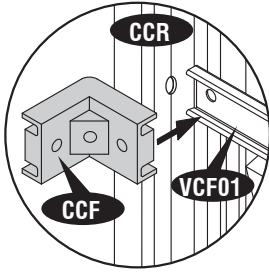
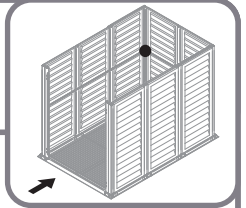

1

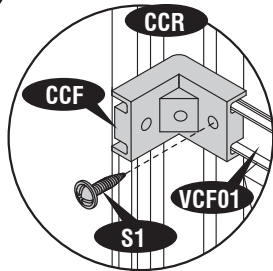

2

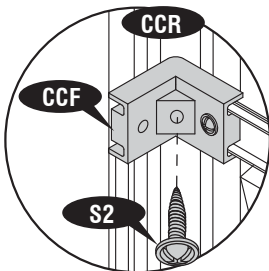

3

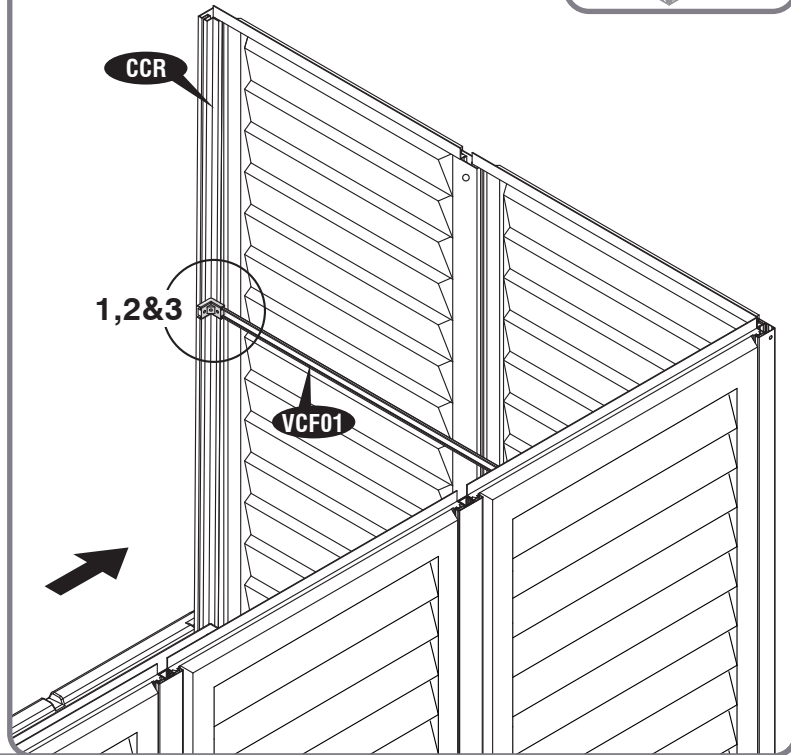

22

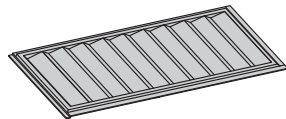

WPE1↑ (x1)

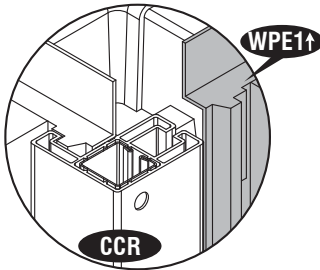
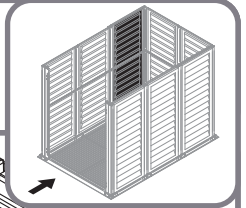

1

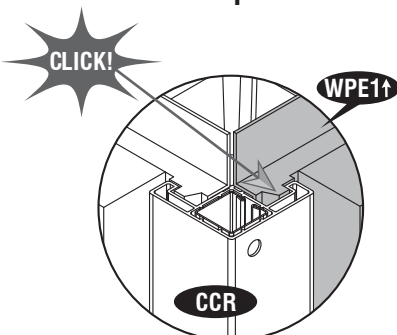

2

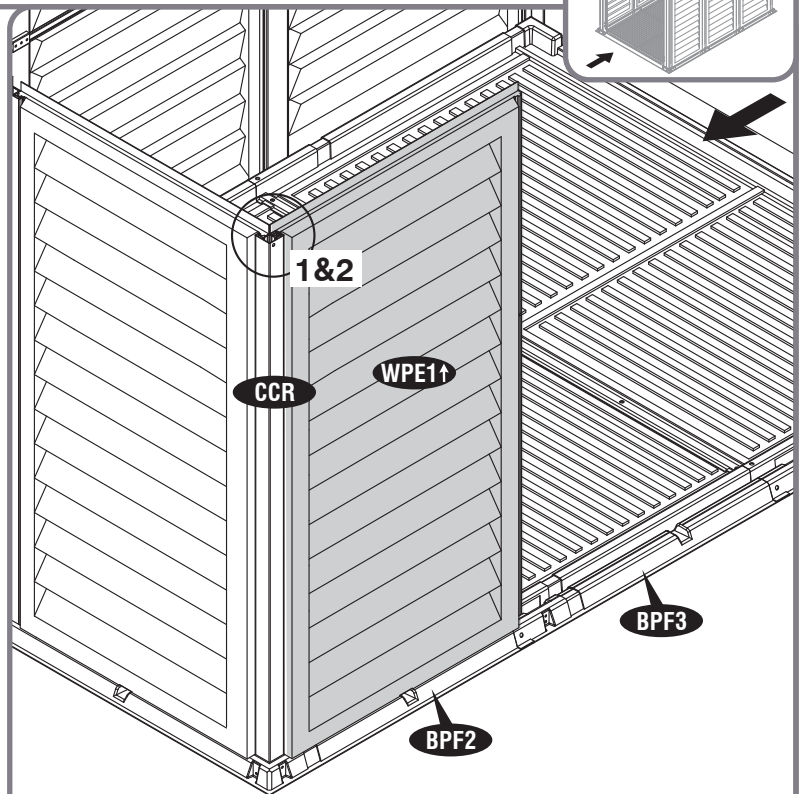

29

23

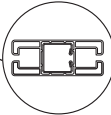
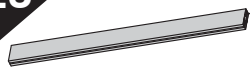

CMR (x1)



S5 (x2)

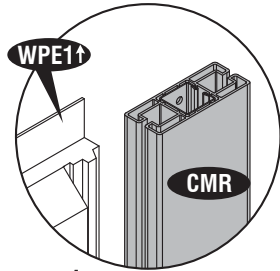
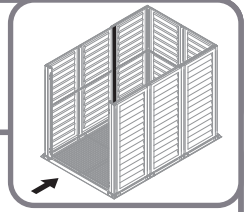

1

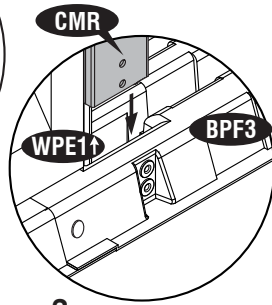

2

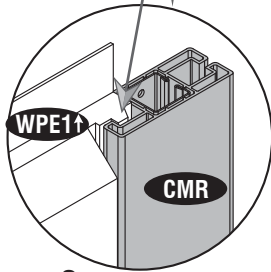

3

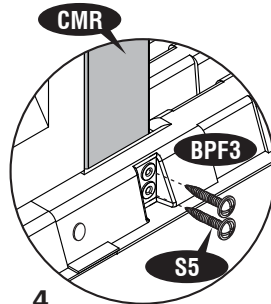

4

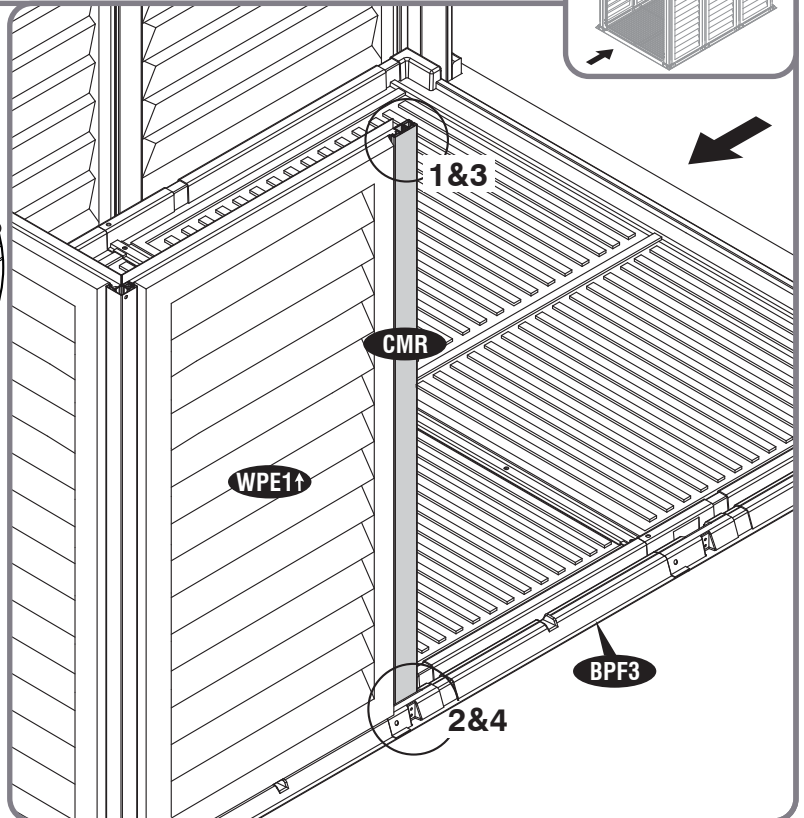

24

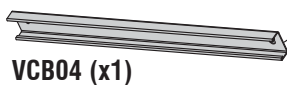

VCB04 (x1)

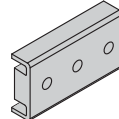
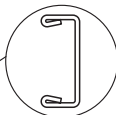

CMF (x1)



S2 (x1)



S1 (x2)

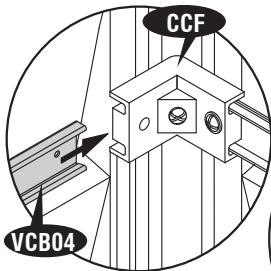
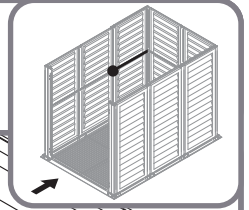

1

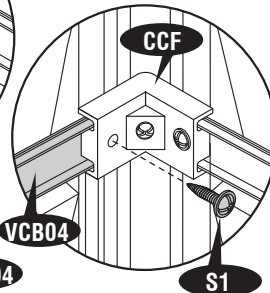

2

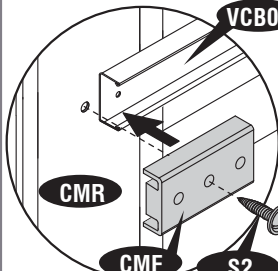

3

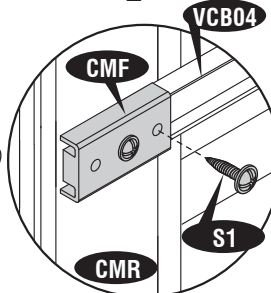

4

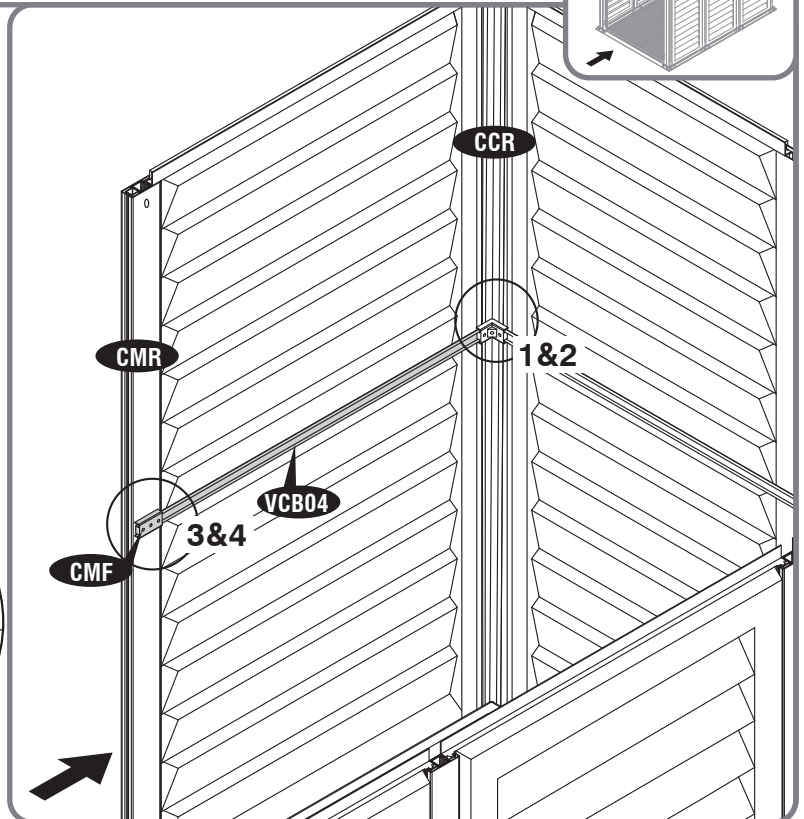

30

25

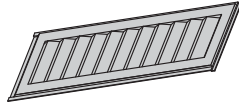

WPE1↑ (x1)

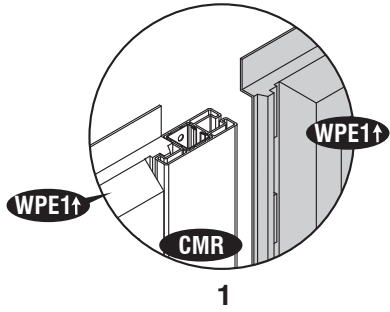
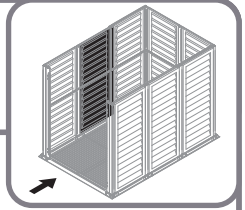

1

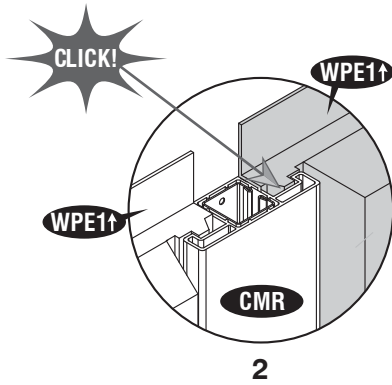

2

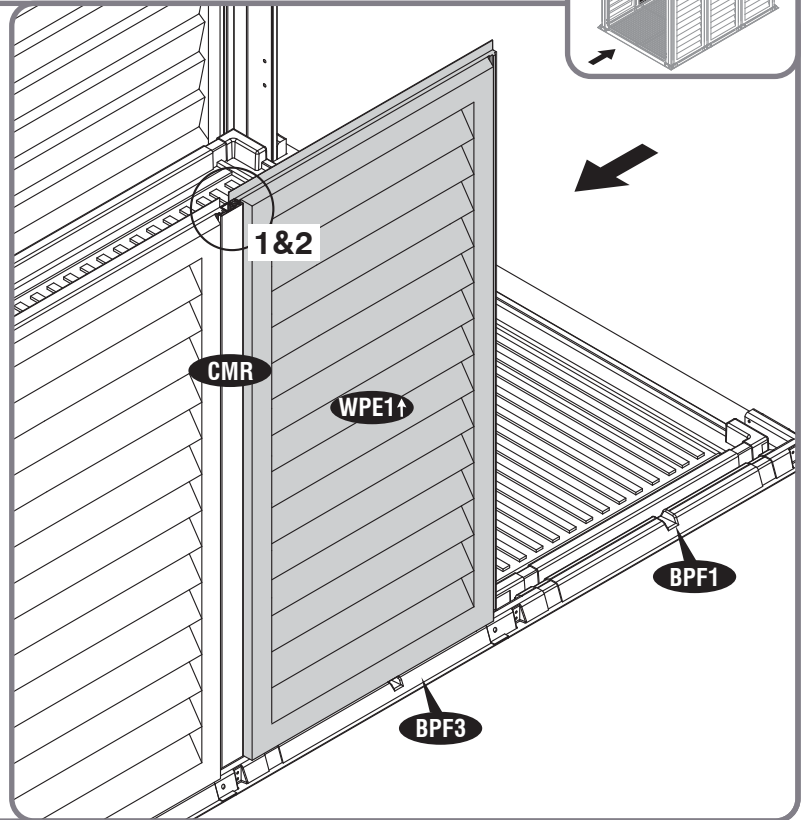

26

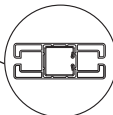
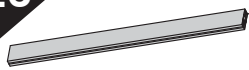

CMR (x1)



S5 (x2)

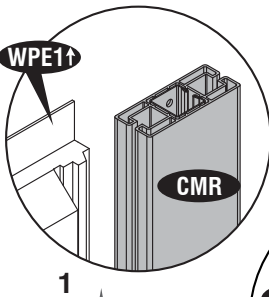
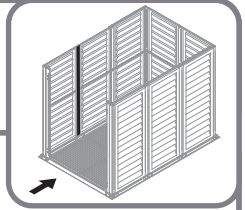

1

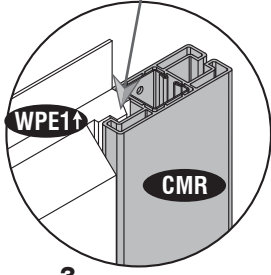

3

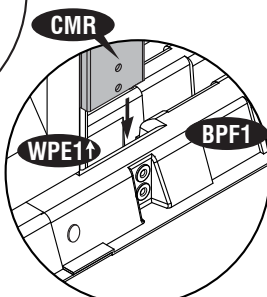

2

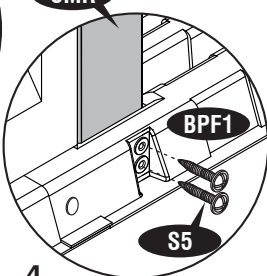

4

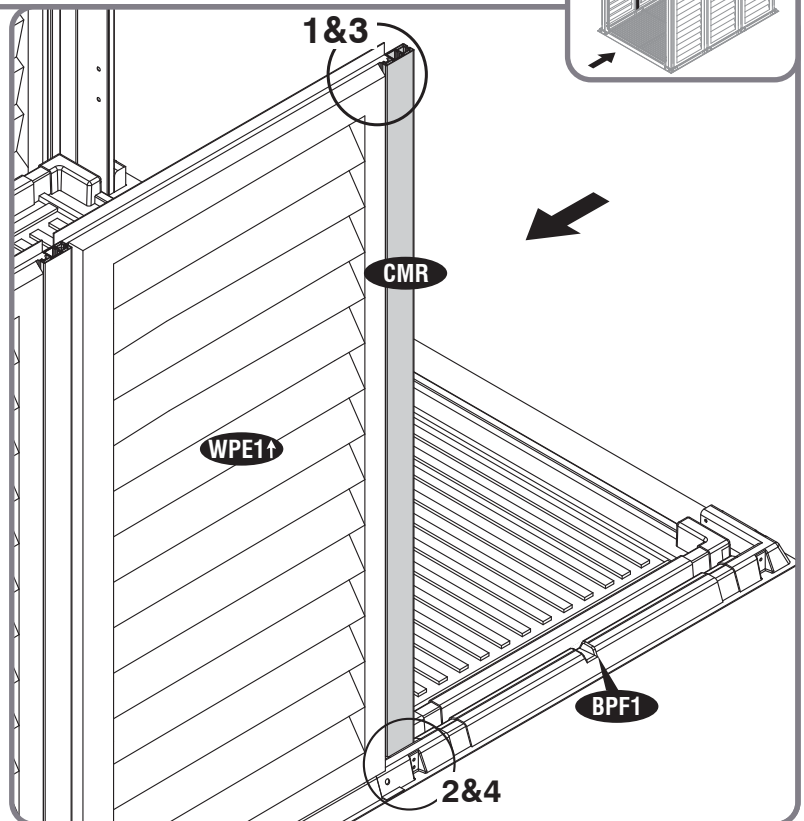

31

27



VCB03 (x1)



S1 (x2)

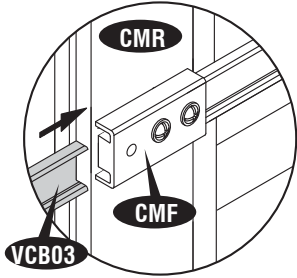
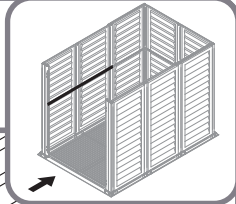

1

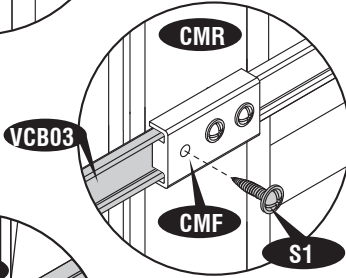

2

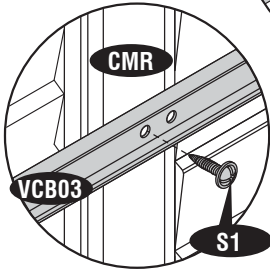

3

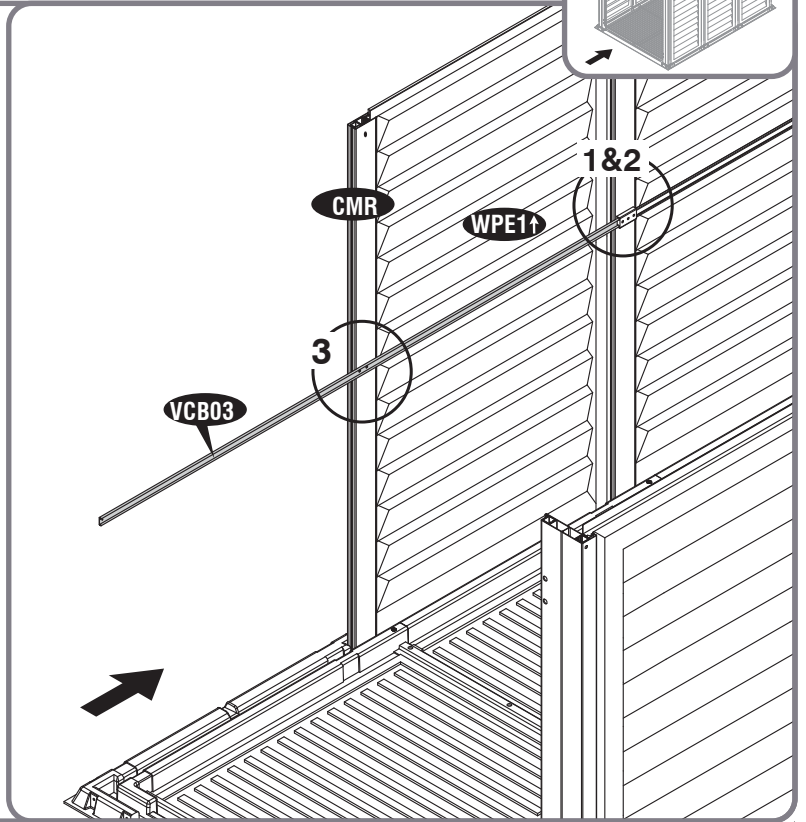

28

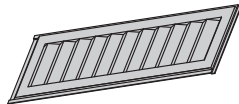

WPE1↑ (x1)

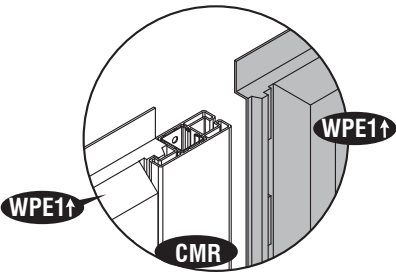
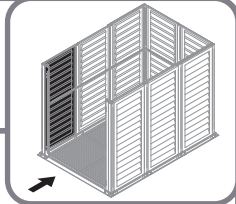

1

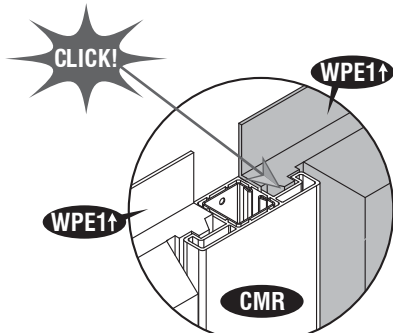

2

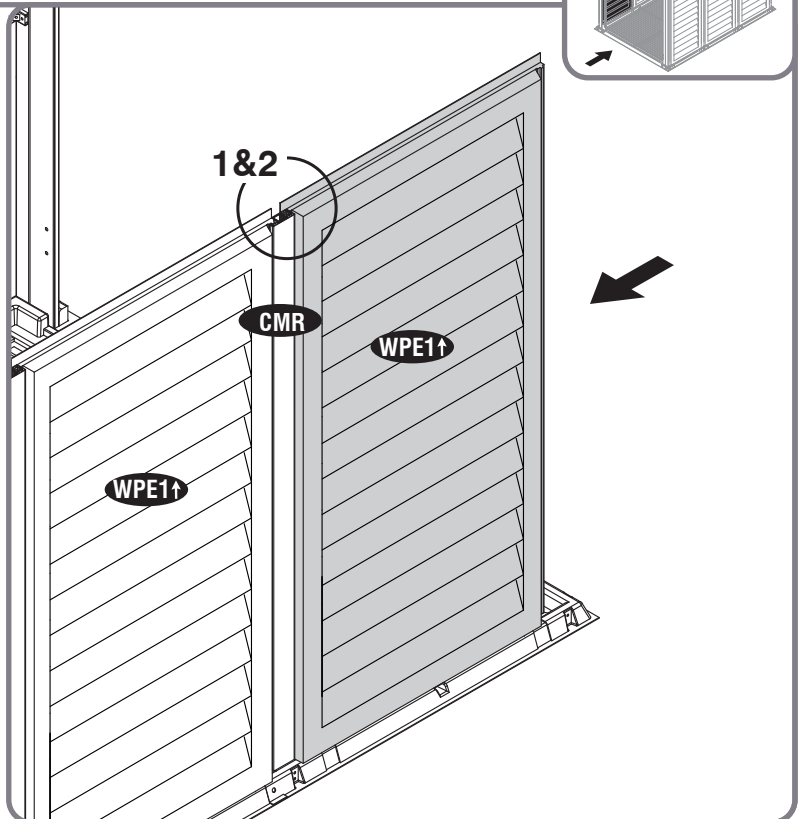

32

29

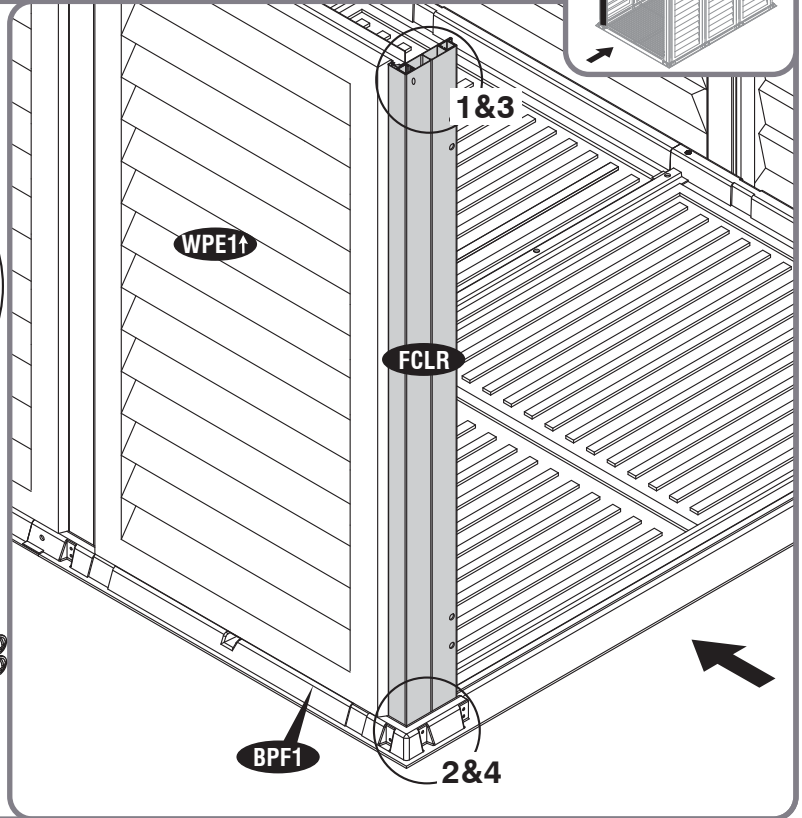
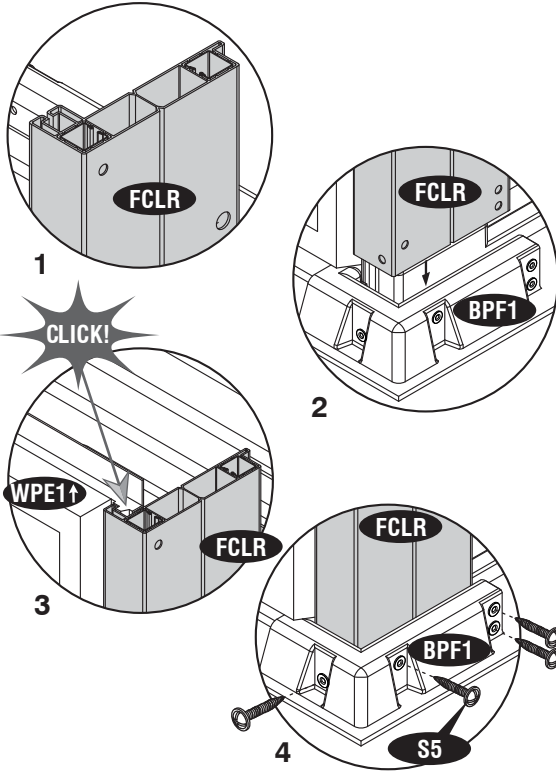
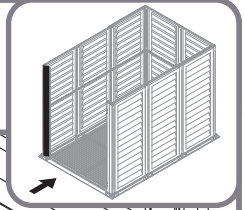
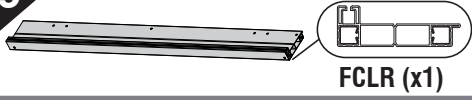

30

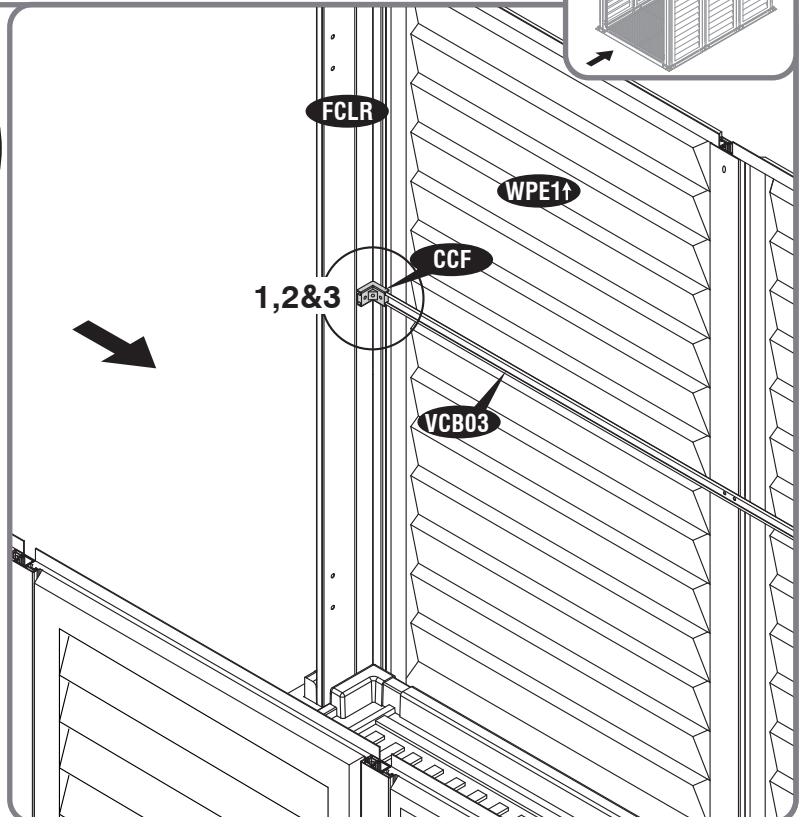
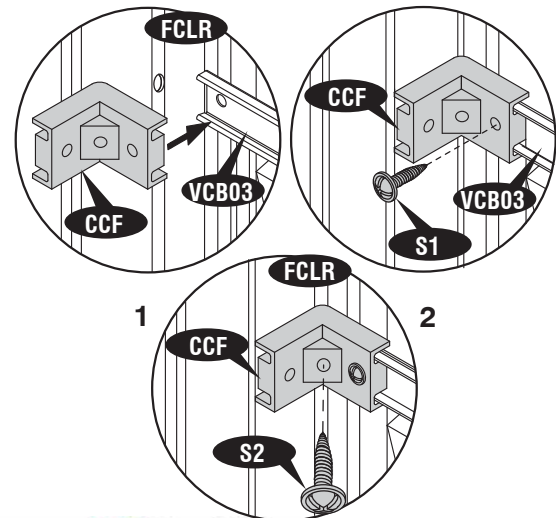
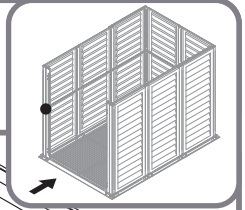
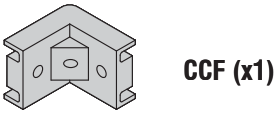

33



2

- | | | |
|-------------------------|-------------------------|--------------------------|
| EN Roof Structures | CS Střešní konstrukce | IT Strutture di tetto |
| FR Structure Du Toit | SK Strešné konštrukcie | PL Struktura dachu |
| DE Dachkonstruktionen | SL Strešne Konstrukcije | RO Structuri de acoperiș |
| ES Estructuras de techo | HR Krovne konstrukcije | BG Покривни конструкции |
| PT Estrutura do Telhado | HU Tetőszerkezetek | TR Çatı yapıları |
| NL Dakconstructies | SV Takstrukturer | |

- | | | |
|-----------------------|-----------------------------------|-----------------------------------|
| EN Parts needed | CS Potřebné součásti | IT Parti occorrenti |
| FR Pièces nécessaires | SK Potrebne časti | PL Niezbędne elementy |
| DE Benötigte Teile | SL Dele, ki jih boste potrebovali | RO Elementele componente necesare |
| ES Piezas necesitadas | HR Dijelovi potreban | BG Необходими части |
| PT Peças Necessárias | HU Szükséges részek | TR Gerekli parçalar |
| NL Onderdelen nodig | SV Delar som behövs | |

VRF01	2	VRA12	2	FDCR	1
VRF02	4	VRA13	1	FCC	4
VRF03	4	VRF06	2	FMC	5
VRF04	1	VRF07	2	RJ	4
VRA06	2	VRF08	4	S1	84
VRA07	2	VRF09	6	S2	4
VJA01	2	FDCL	1	S7	44



1

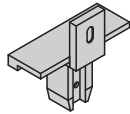

FMC (x5)



S1 (x5)

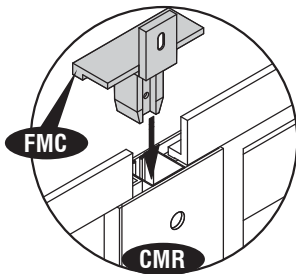
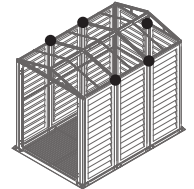

1

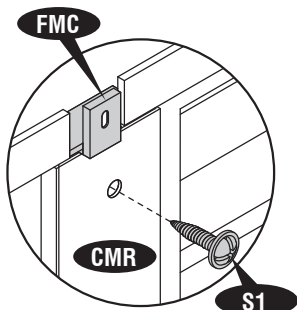

2

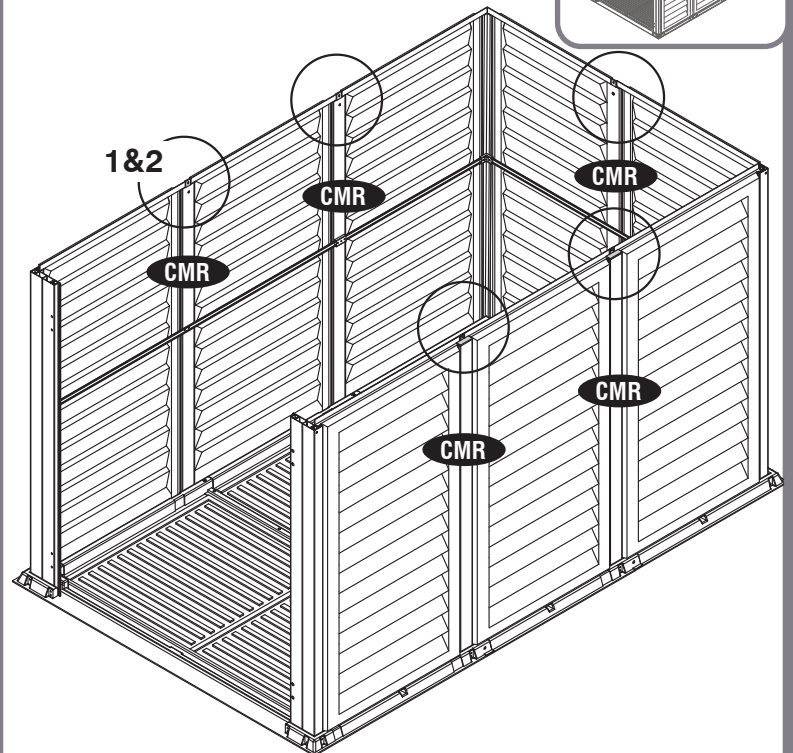

2

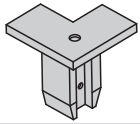

FCC (x4)



S1 (x4)

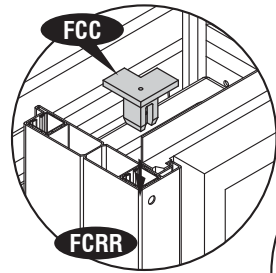
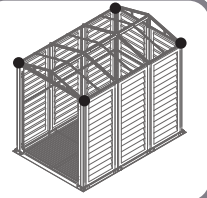

1

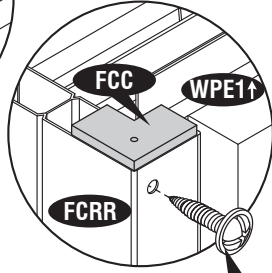

2

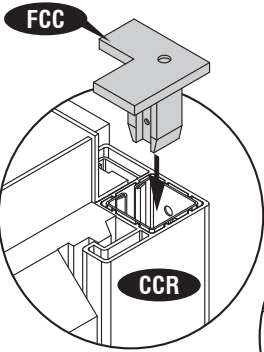

3

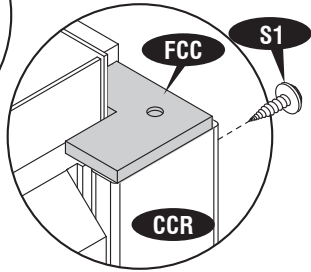

4

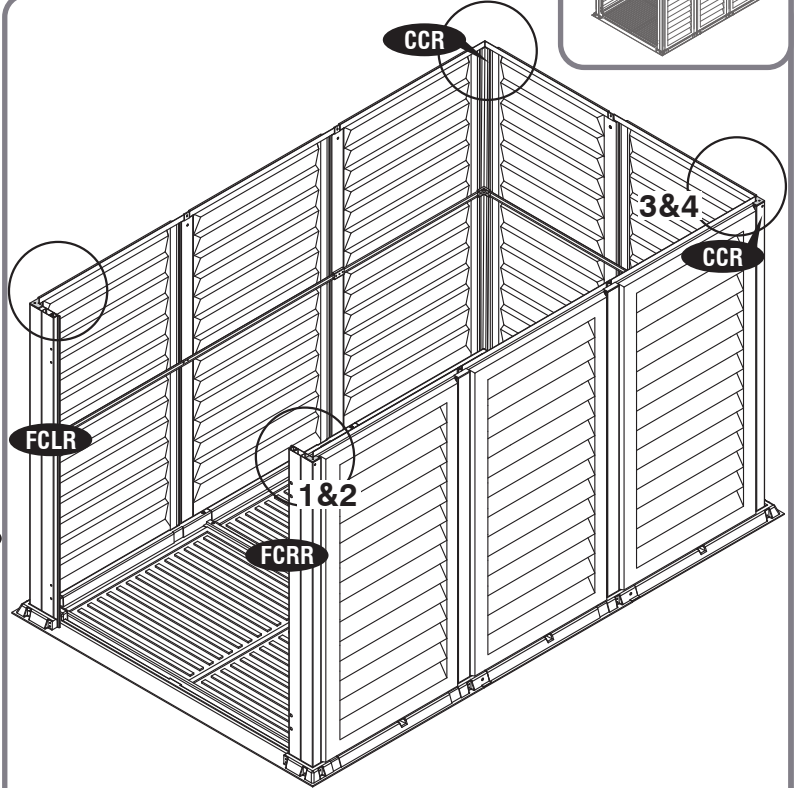

3



FDCL (x1)

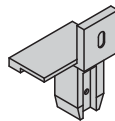

FDCR (x1)



S1 (x2)

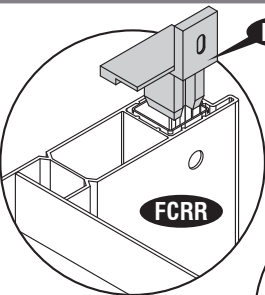
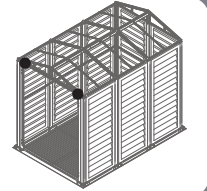

1

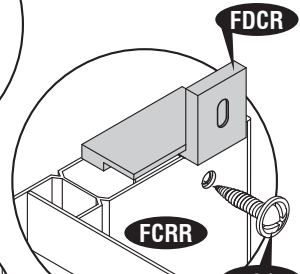

2

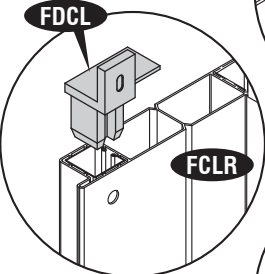

3

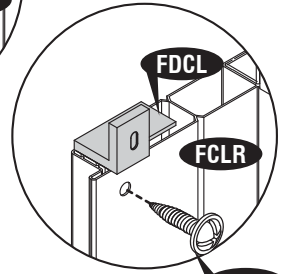

4

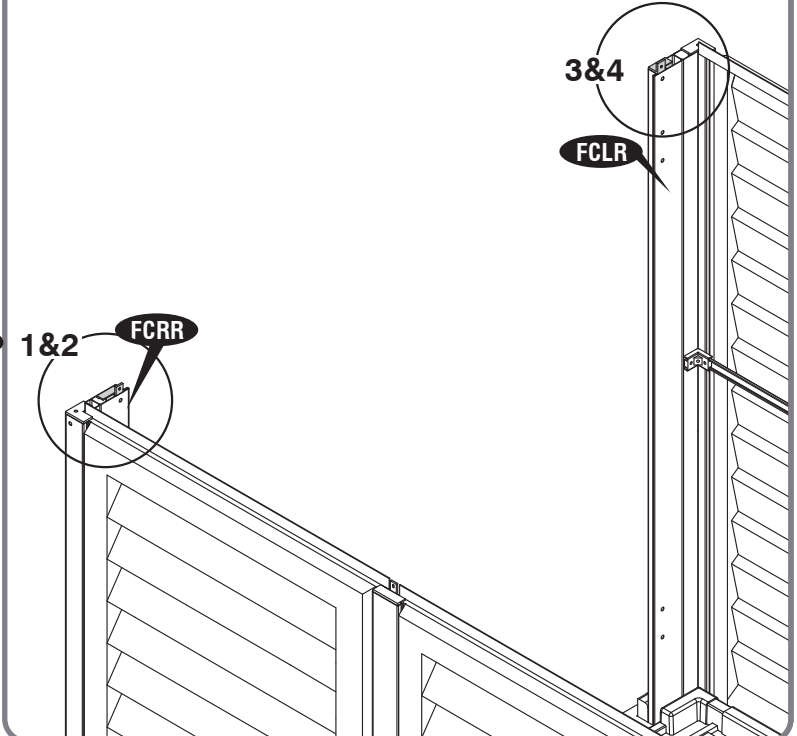

- | | | | |
|----|--------------------------------------|----|---------------------------------|
| EN | Roof Structure Assembly | HR | Sklop krovne konstrukcije |
| FR | Assemblage De La Structure Du Toit | HU | Tetőszerkezet szerelvény |
| DE | Dachkonstruktion Montage | SV | Takkonstruktion |
| ES | Montaje de la estructura de techo | IT | Assemblea tetto della struttura |
| PT | Armação da Estrutura do Telhado | PL | Montaż konstrukcji dachu |
| NL | Dakconstructie montage kit | RO | Coinneamh Structar Deil |
| CS | Montážní souprava střešní konstrukce | BG | Покривна конструкция събрание |
| SK | Montáž konštrukcie strechy | TR | Çatı Yapısı Meclisi |
| SL | Sestavni Deli Strešne Konstrukcije | | |

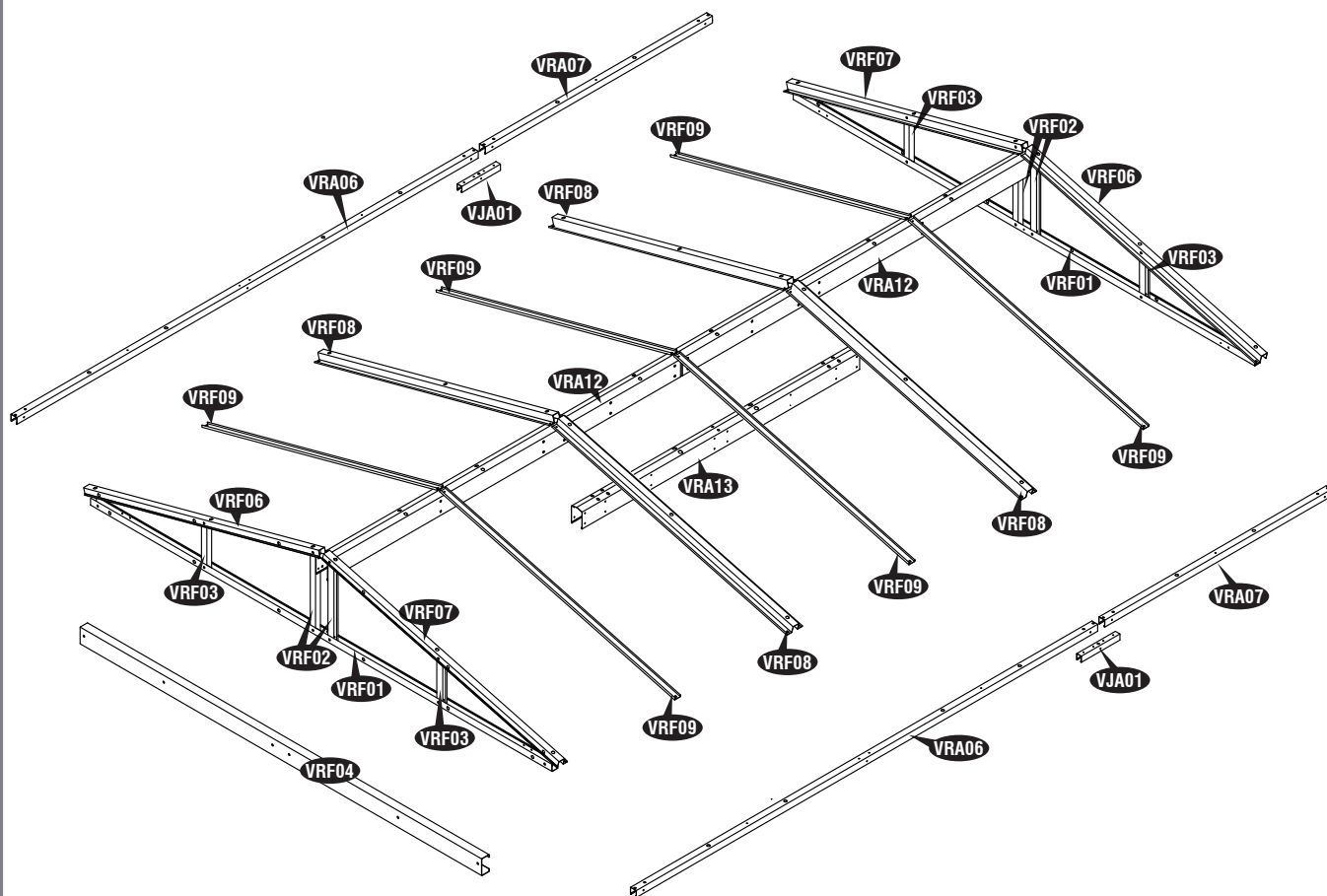

EN Front Roof Structure Assembly

FR Assemblage De La Structure Avant Du Toit

DE Vordere Dachkonstruktion Montage

ES Montaje de la estructura de techo frontal

PT Armação da Estrutura do Telhado Frontal

NL Voorste dakconstructie montage kit

CS Montážní souprava přední střešní konstrukce

SK Montáž konštrukcie prednej strechy

SL Sestavni Del Prednje Strešne Konstrukcije

HR Prednja sklopa krovne konstrukcije

HU Első tetőszerkezet szerelvény

SV Frammonterad takkonstruktion

IT Assemblea anteriore tetto della struttura

PL Montaż konstrukcji dachu przedniego

RO Frontul șarpanta Adunarea

BG Предна покривна конструкция събрание

TR Ön Çatı Yapısı Kompleksi

A

4



VRF01 (x1)

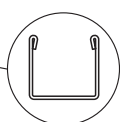

VRF02 (x2)
VRF03 (x2)

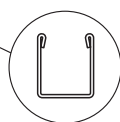

S1 (x4)

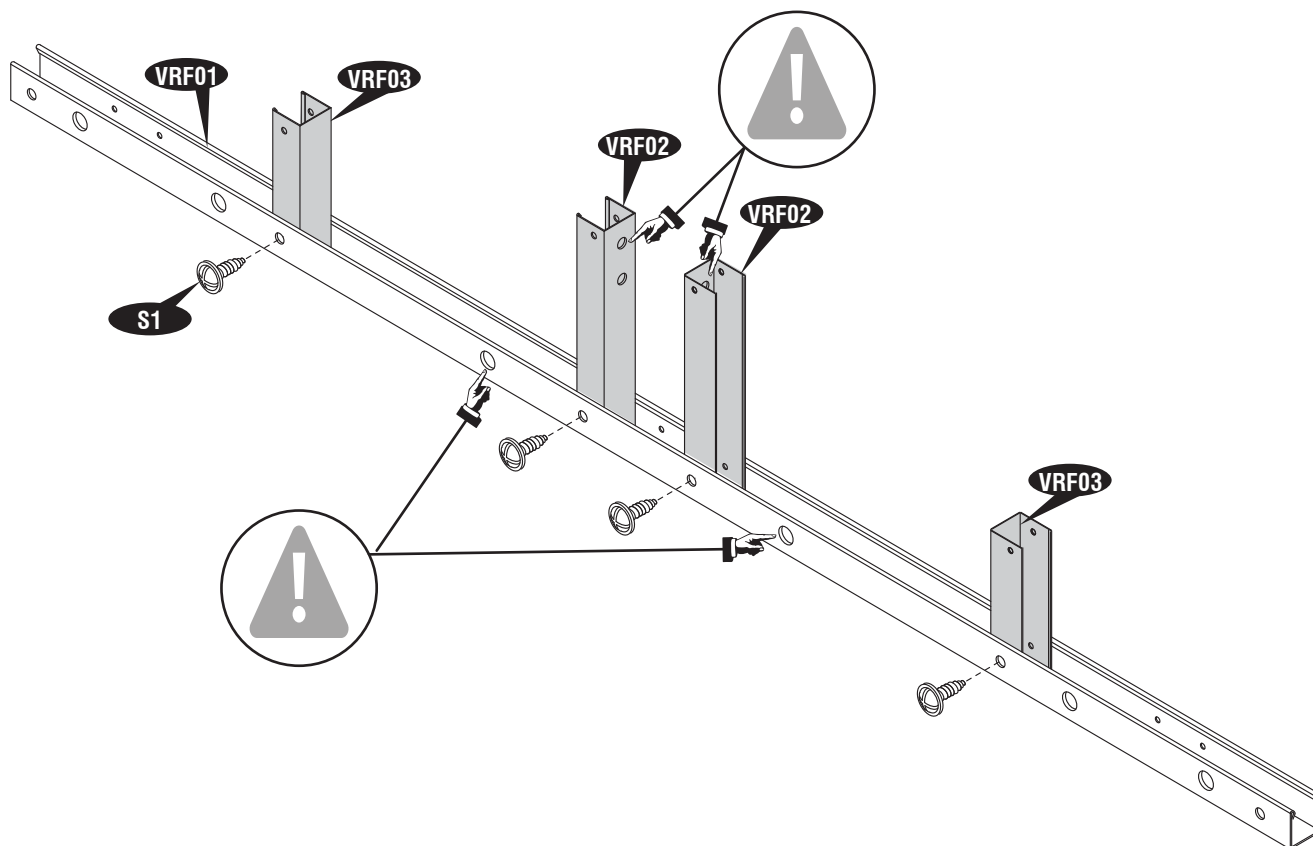
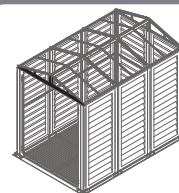

5

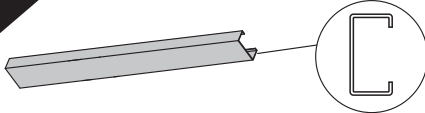

VRF04 (x1)



S1 (x6)

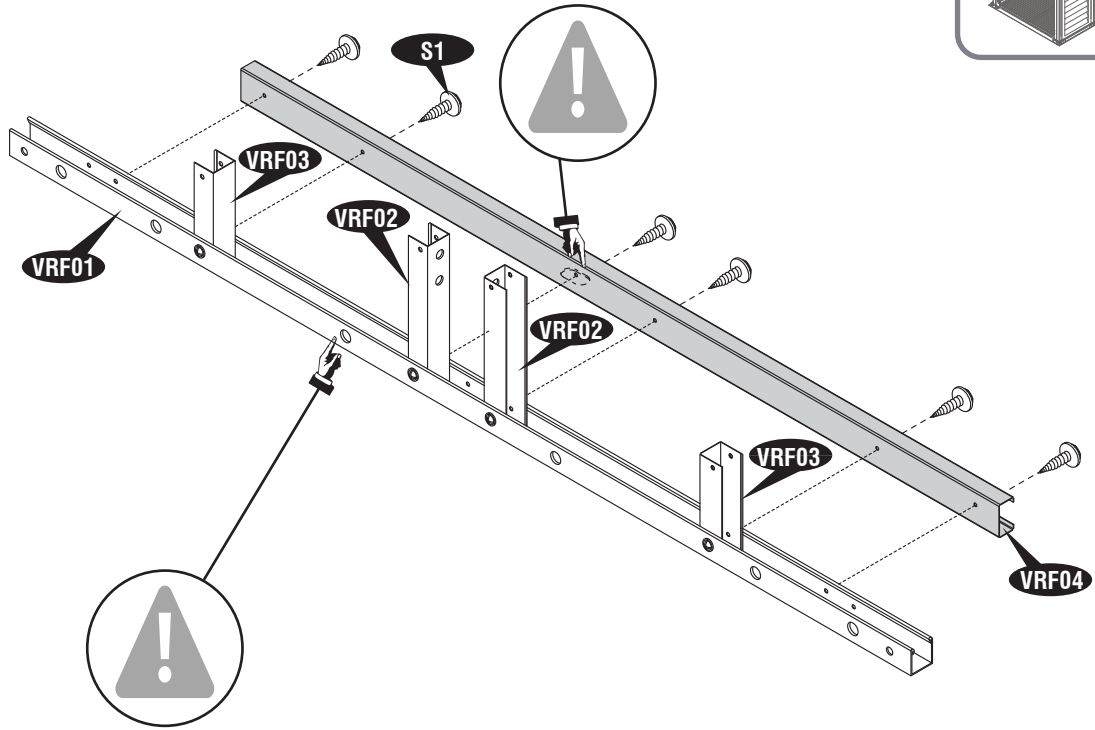
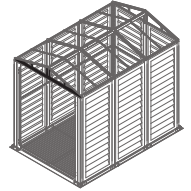

6

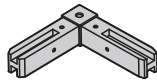

RJ (x2)



S1 (x2)

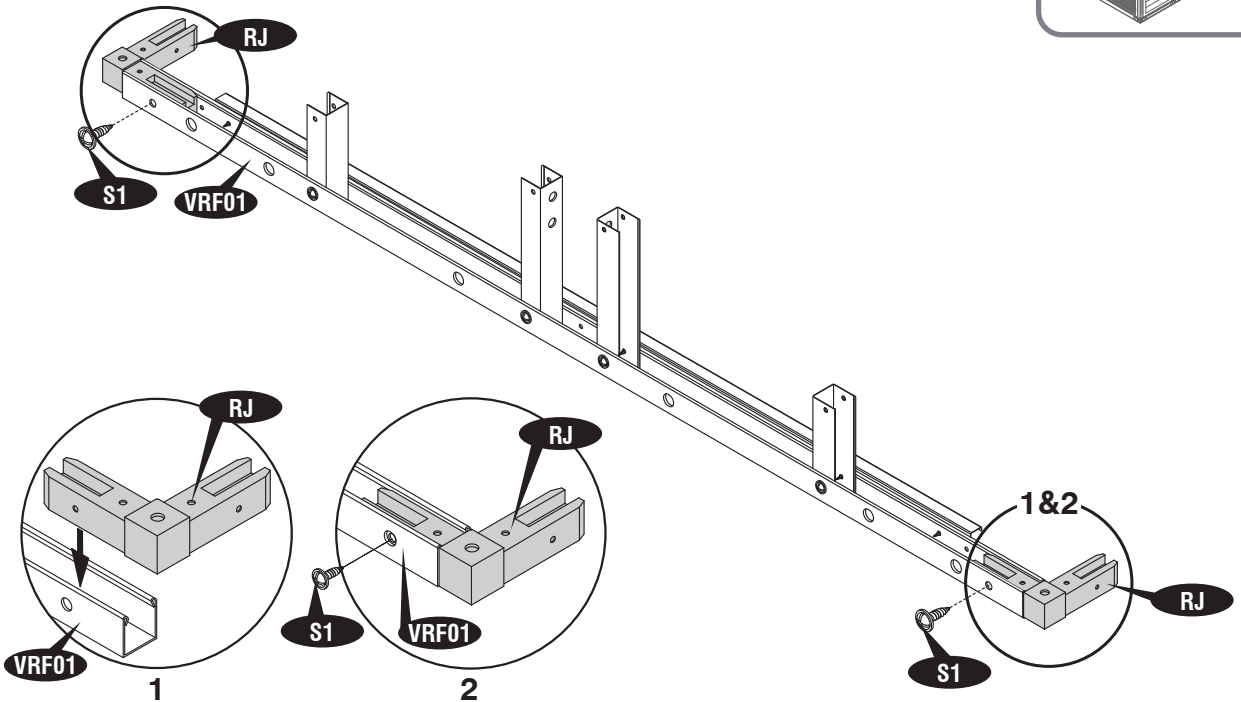
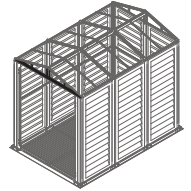

- | | | | | |
|----------|--|--|--|--|
| EN | Back Roof Structure Assembly | HR | Sastavni dio krovne strukture | |
| FR | Assemblage De La Structure Arriere Du Toit | HU | Vissza Tetőszerkezet szerelvény | |
| DE | Hintere Dachkonstruktion Montage | SV | Bakre takkonstruktion | |
| ES | Montaje de la estructura de techo trasera | IT | Assemblea Struttura posteriore del tetto | |
| B | PT | Armação da Estrutura do Telhado Traseiro | PL | Montaż tylniej konstrukcji dachu |
| | NL | Achter dakconstructie montage kit | RO | Structura de asamblare Înapoi acoperiș |
| | CS | Montážní souprava zadní střešní konstrukce | BG | Структура събрание Обратно Покрив |
| | SK | Zadné strešné koňtrukcie Montáž | TR | Arka Çatı Yapısı Kompleksi |
| | SL | Sestavni Del Zadnje Strešne Konstrukcije | | |

7

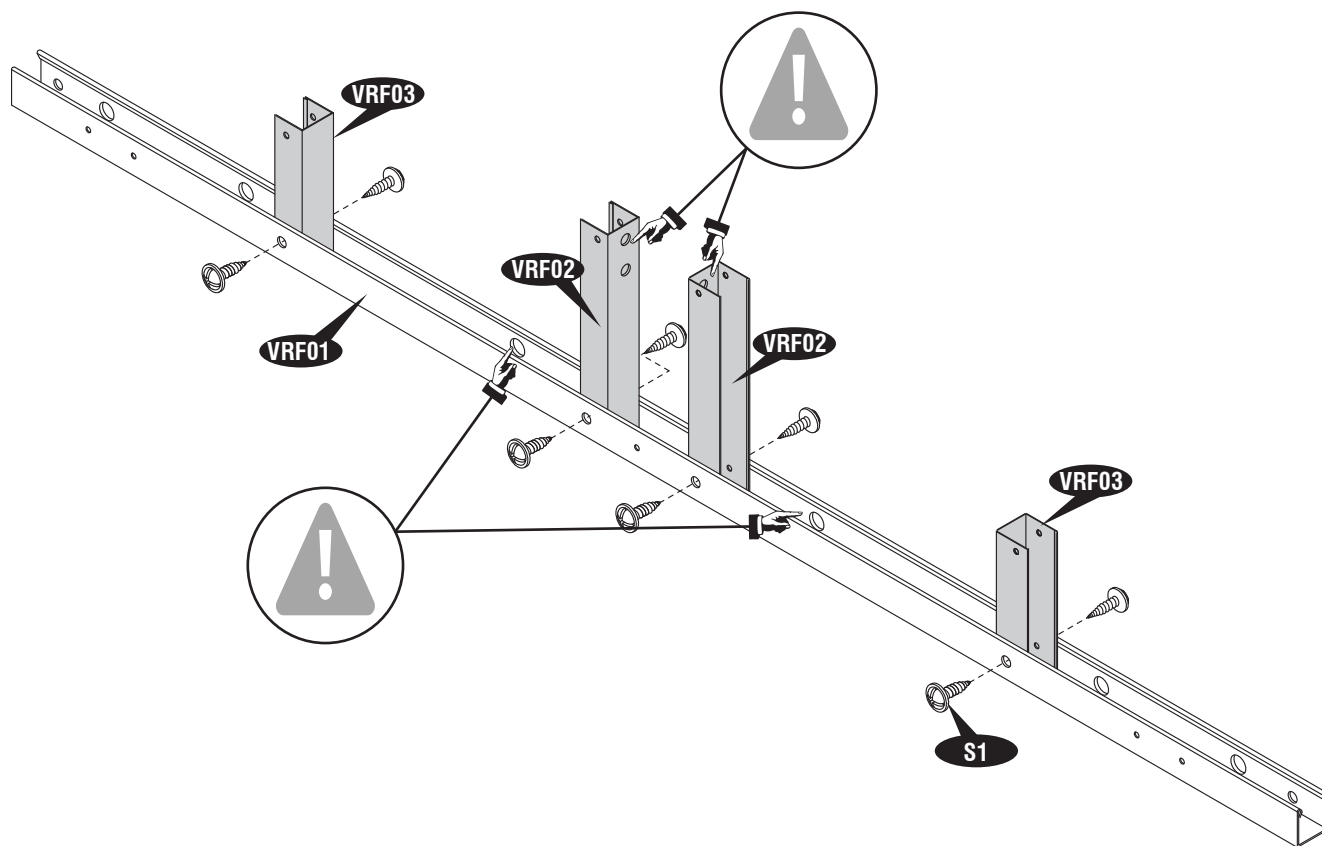
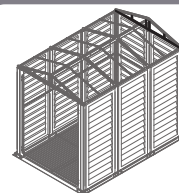
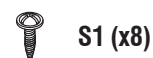
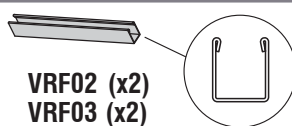
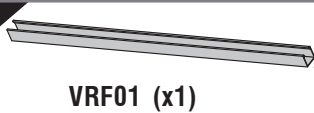

8

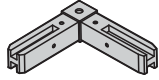

RJ (x2)



S1 (x2)

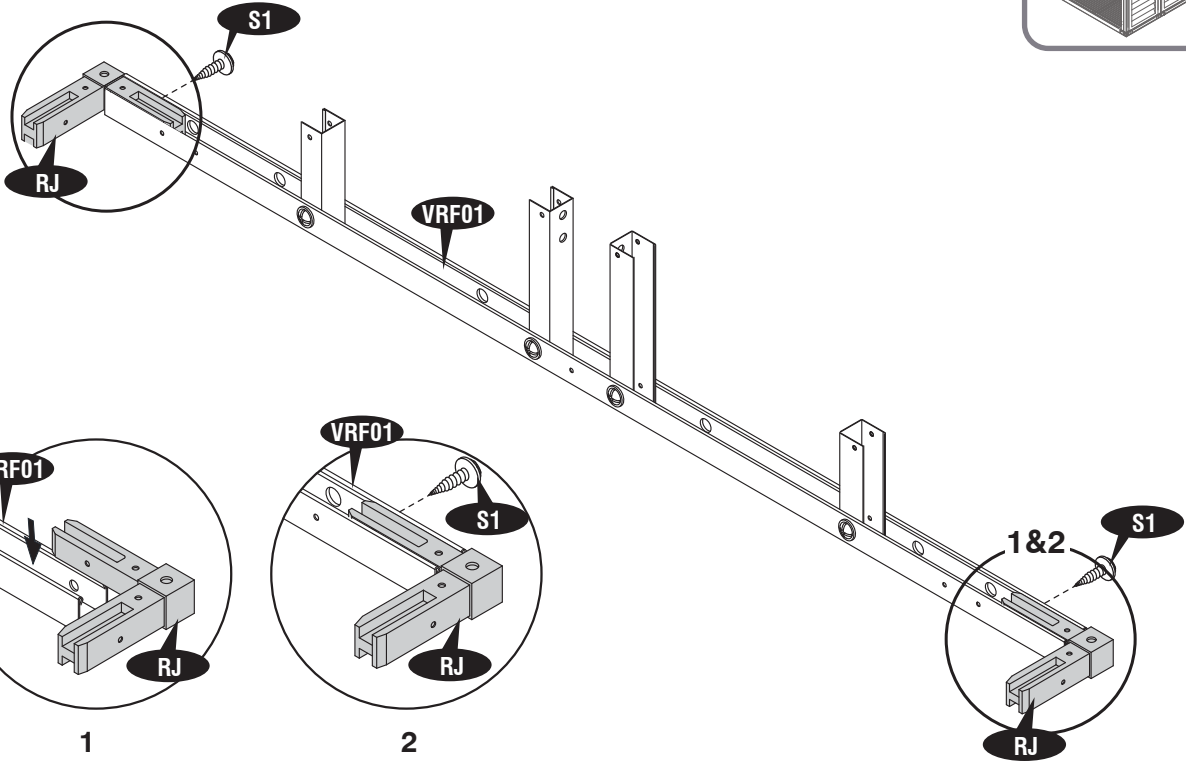
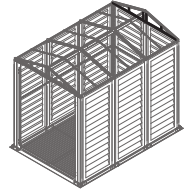

9

VRA06 (x2)

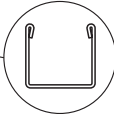

VRA07 (x2)

VJA01 (x2)

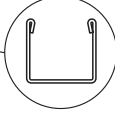

S1 (x4)

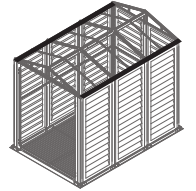

x2

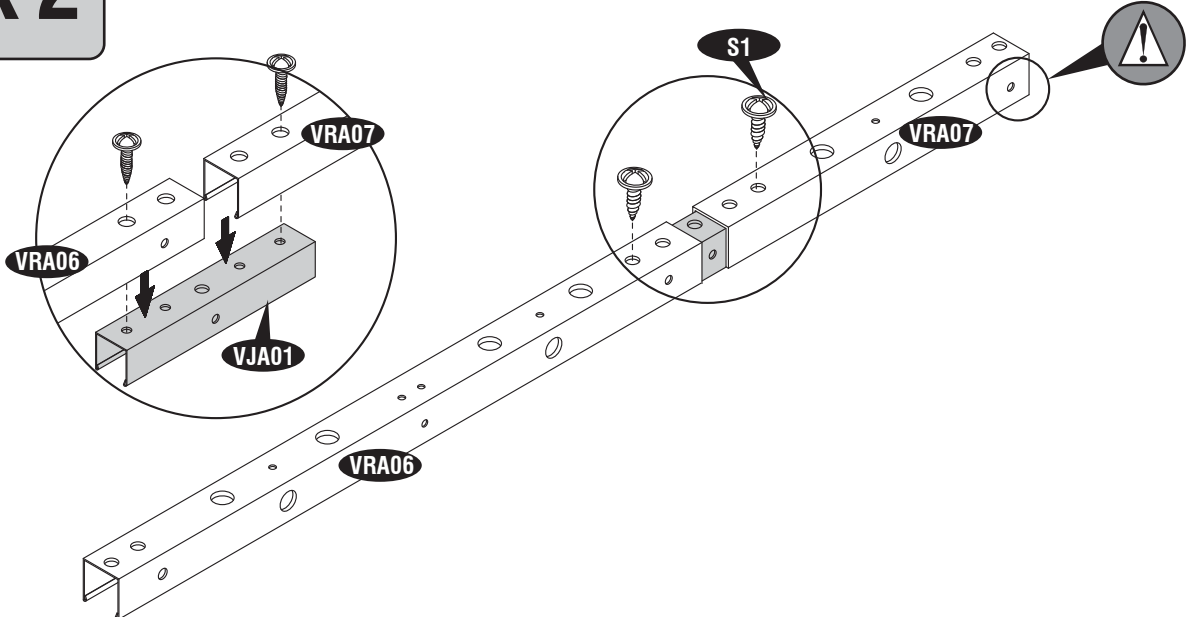

10

VRA12 (x2)

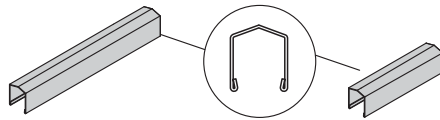

VRA13 (x1)

S7 (x24)

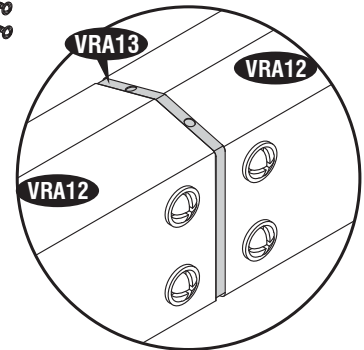
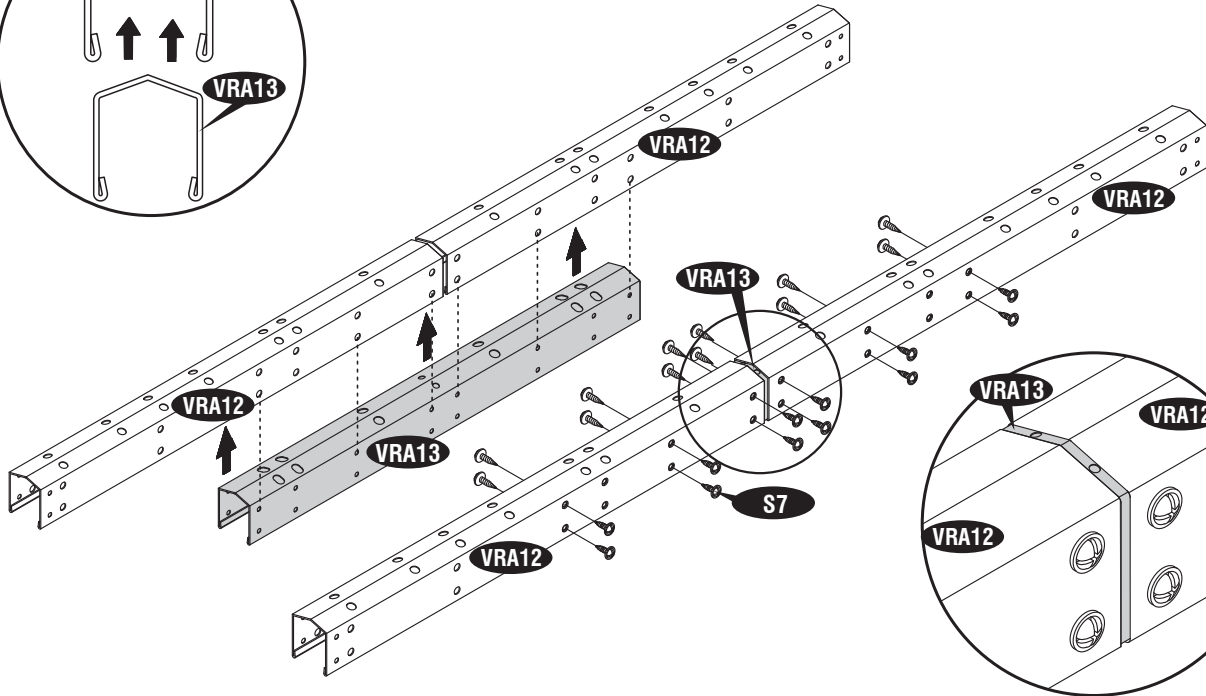
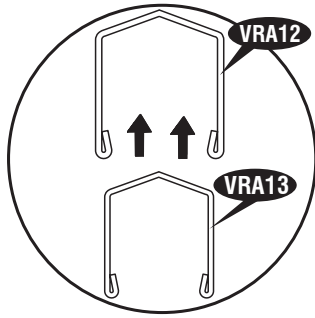
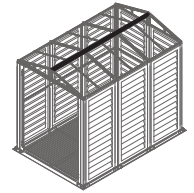

11

A (x1)

S1 (x2)

S2 (x2)

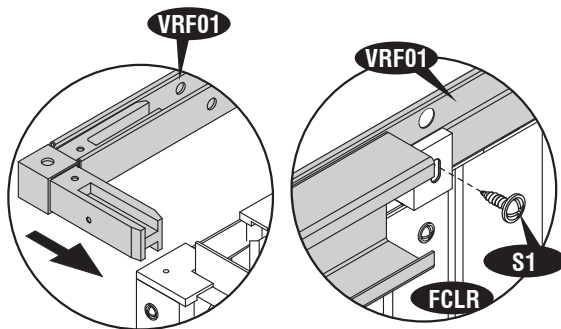
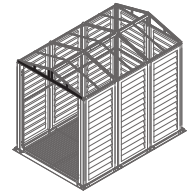

1

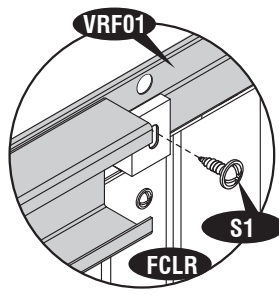

2

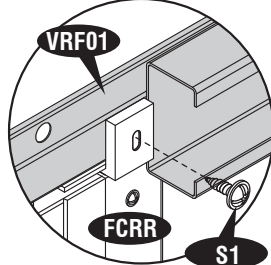

3

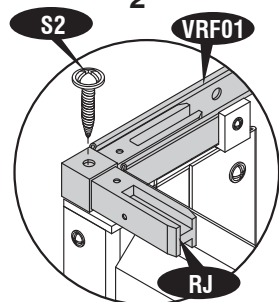

4

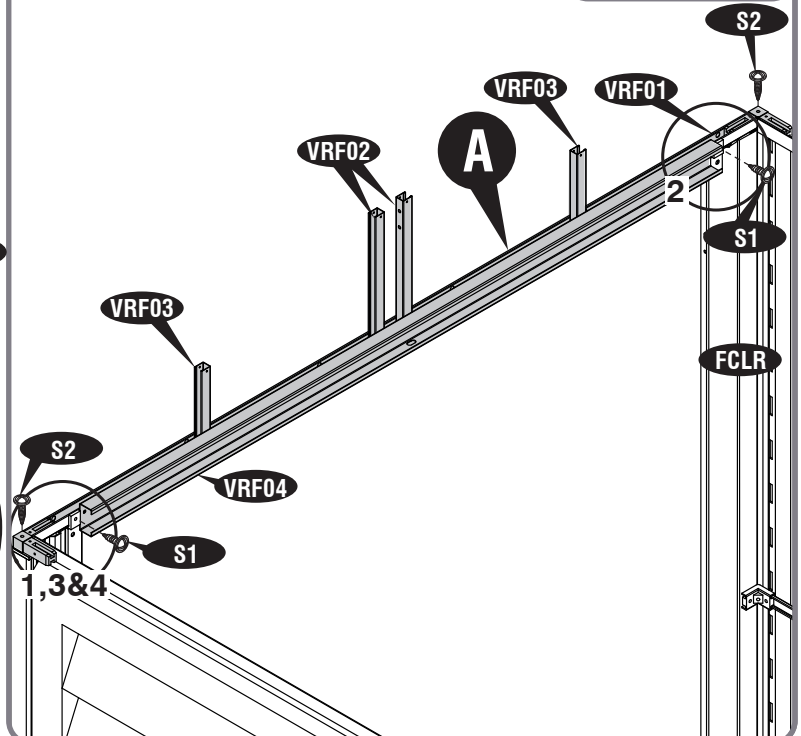

12

B (x1)

S1 (x1)

S2 (x2)

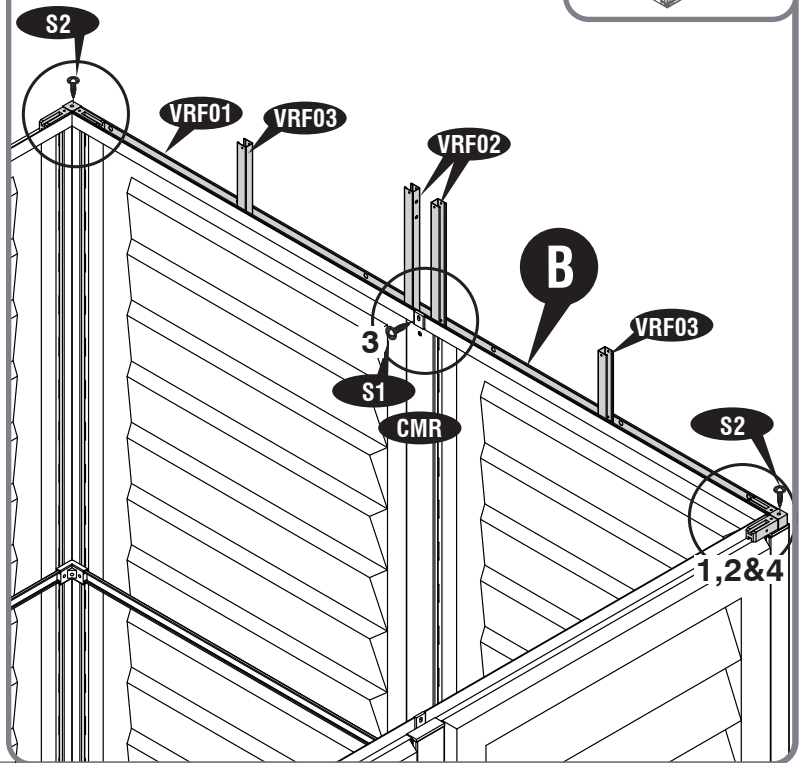
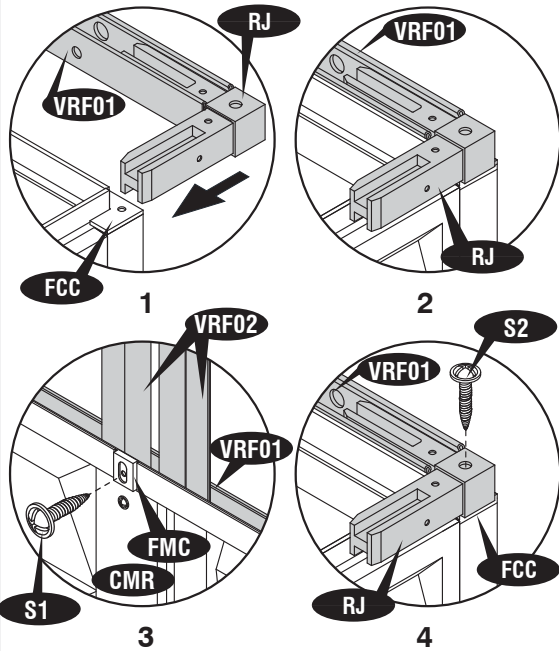
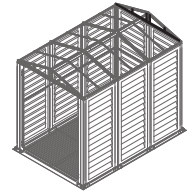

13

S1 (x4)

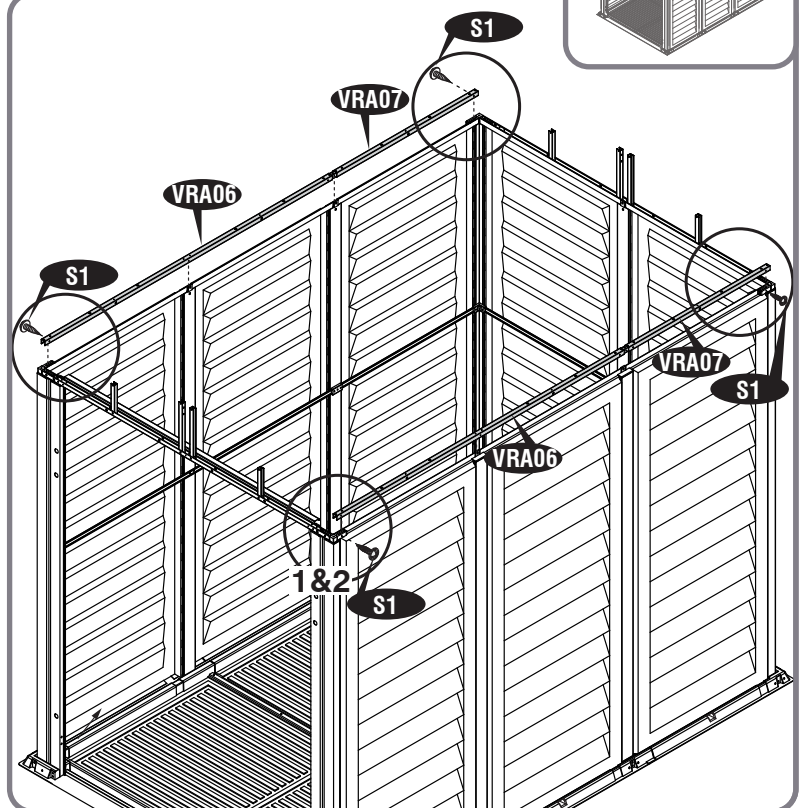
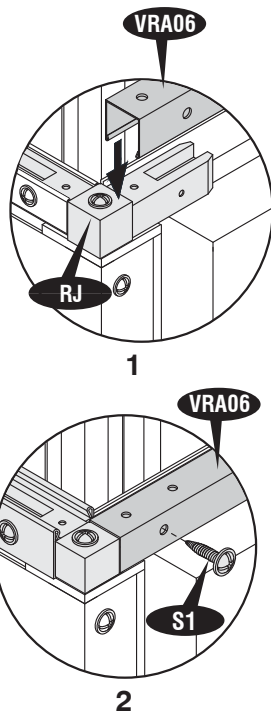
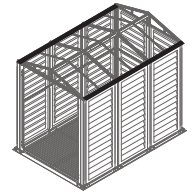

14

S1 (x4)

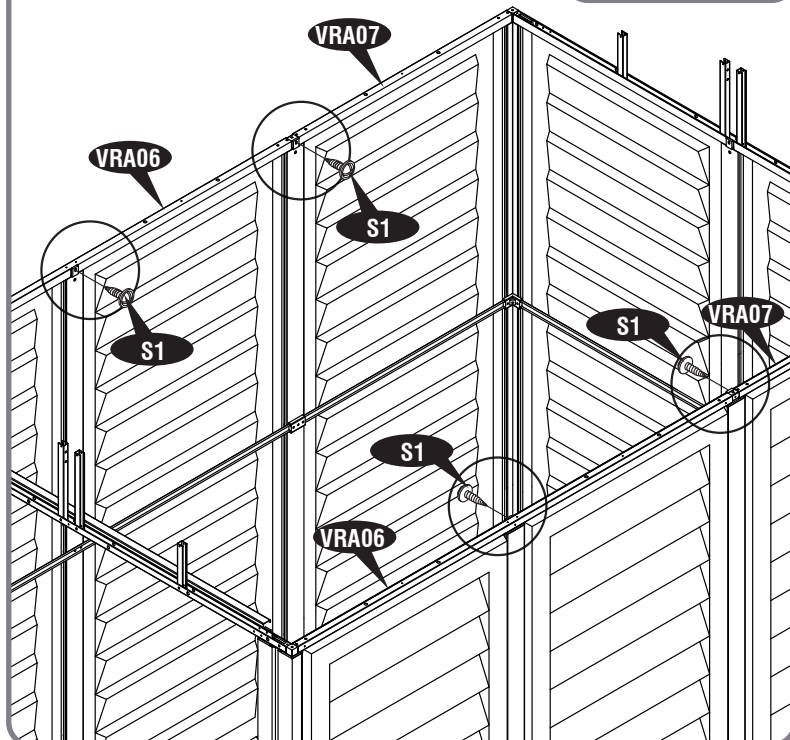
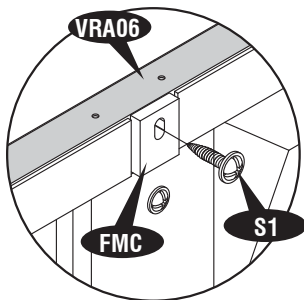
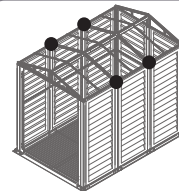

15

S1 (x8)

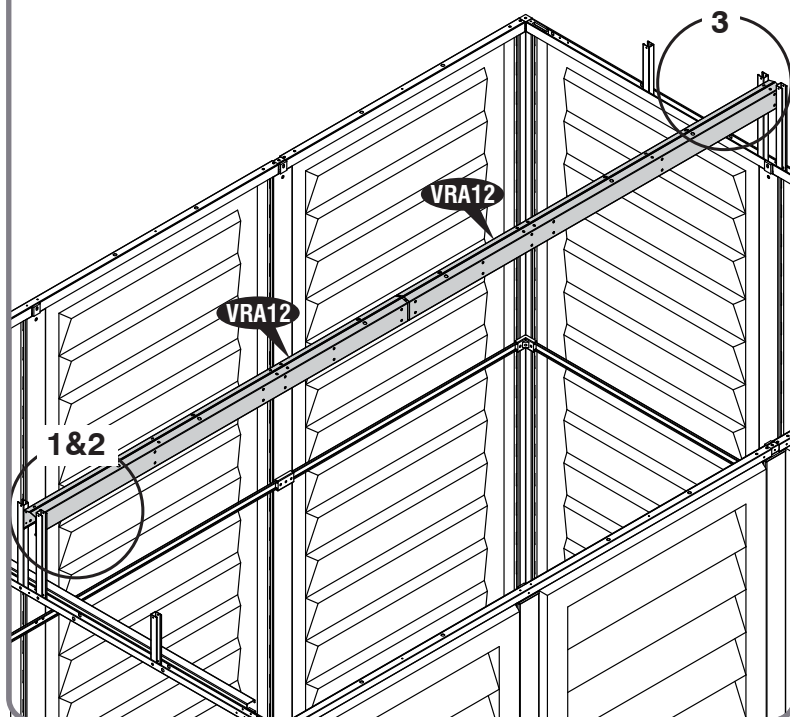
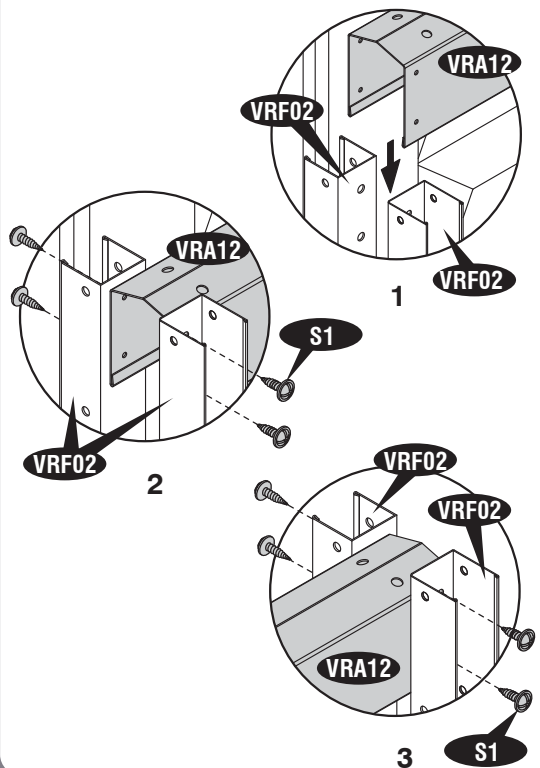
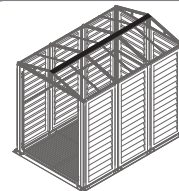

16

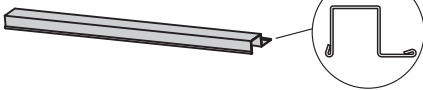

VRF06 (x1)
VRF07 (x1)

S1 (x10)

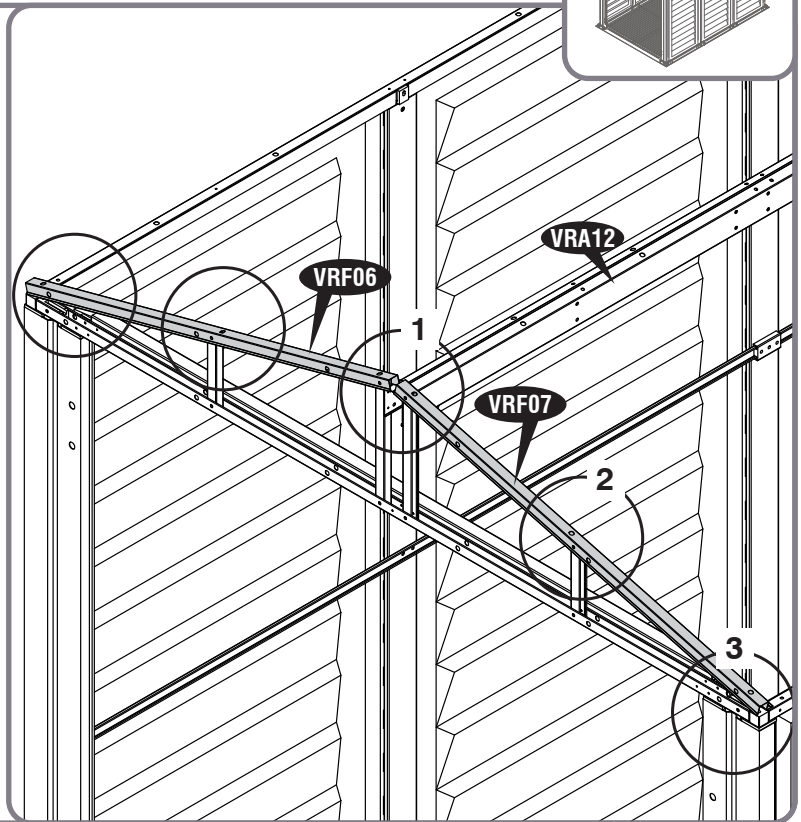
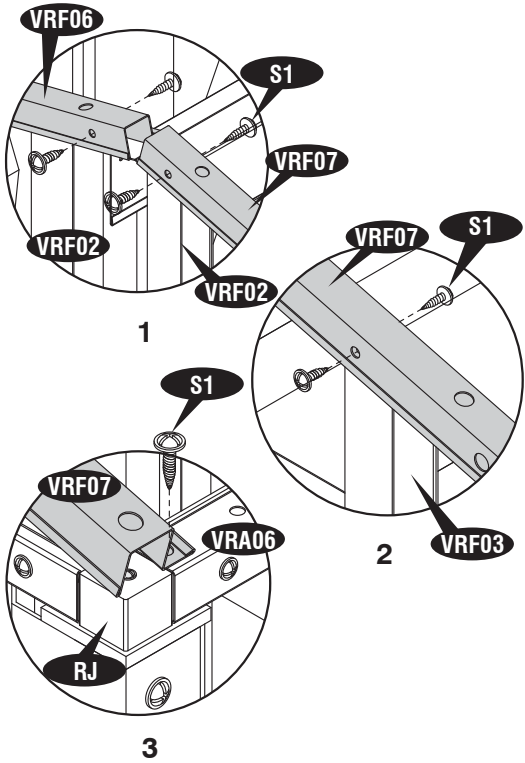
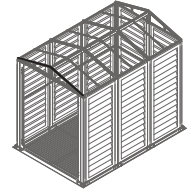

17

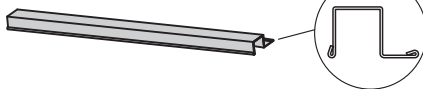

VRF06 (x1)
VRF07 (x1)

S1 (x10)

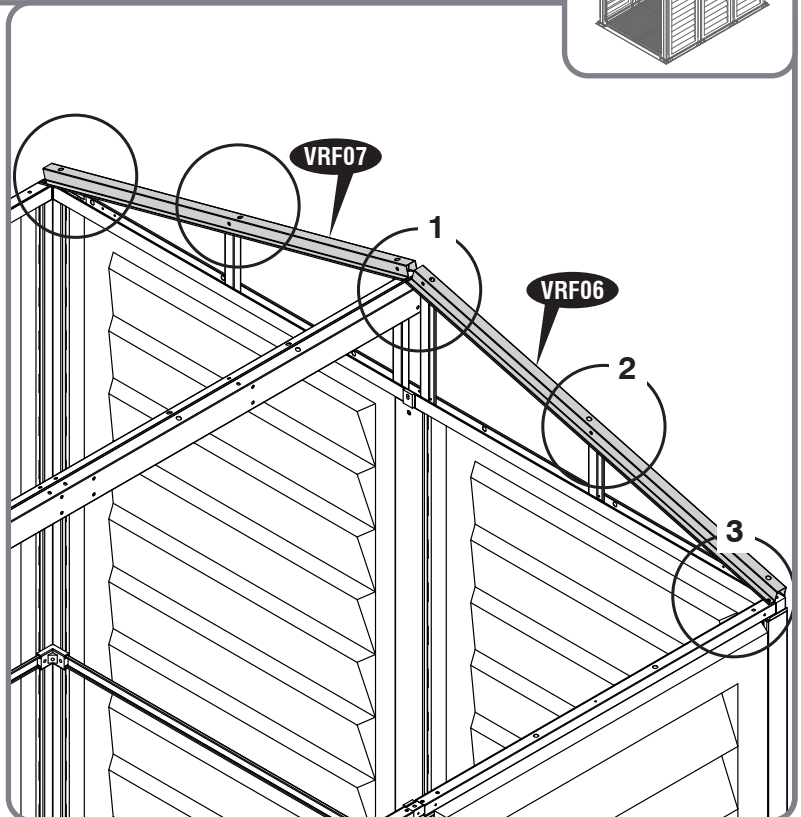
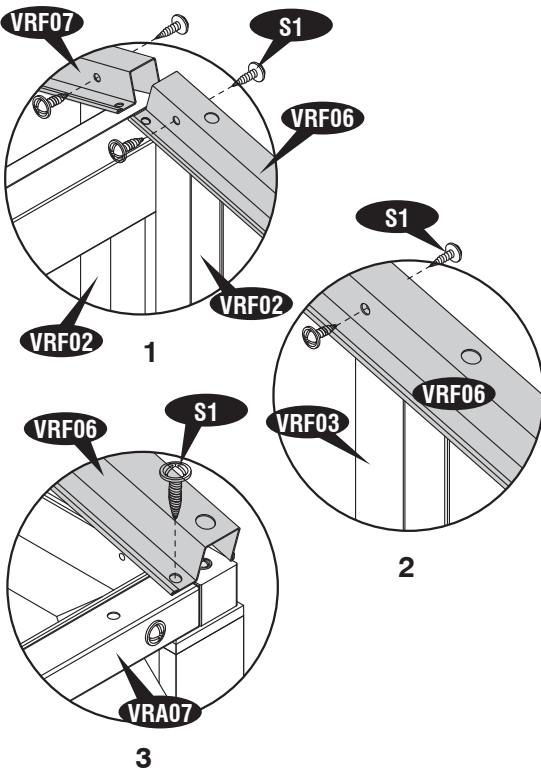
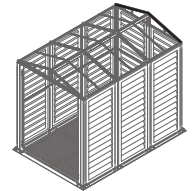

18

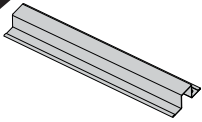

VRF08 (x4)

S1 (x8)

S7 (x8)

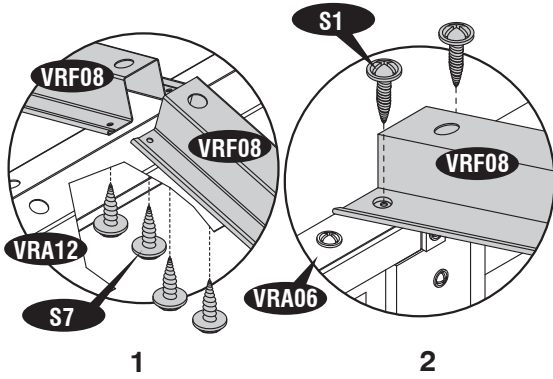
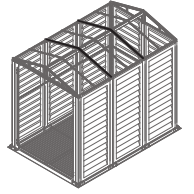

1

2

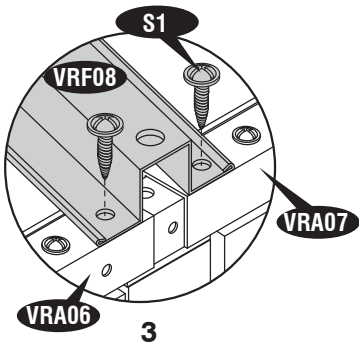

3

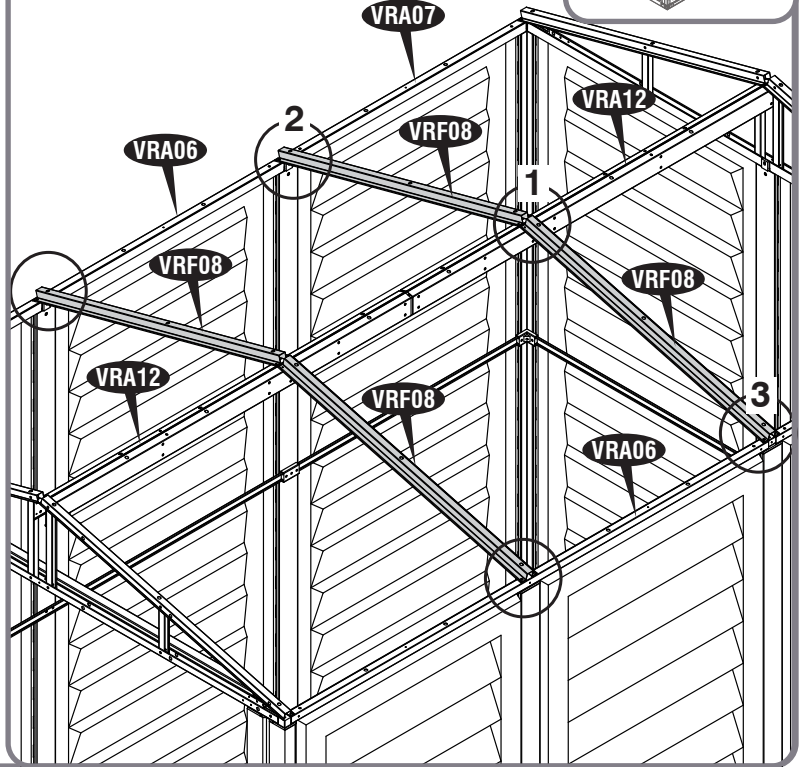

19

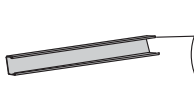

VRF09 (x6)

S7 (x12)

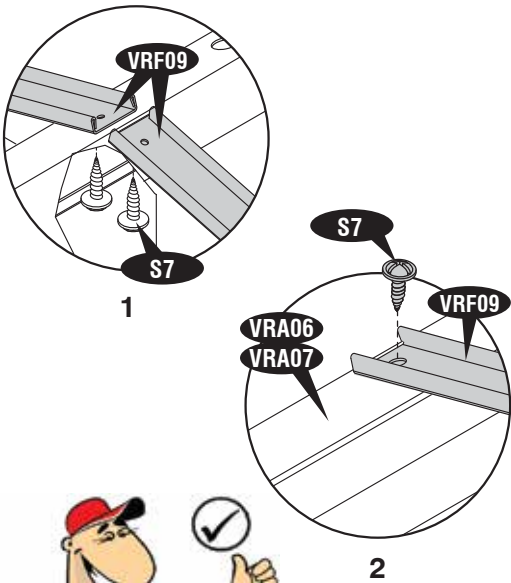
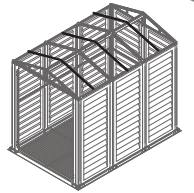

1

2

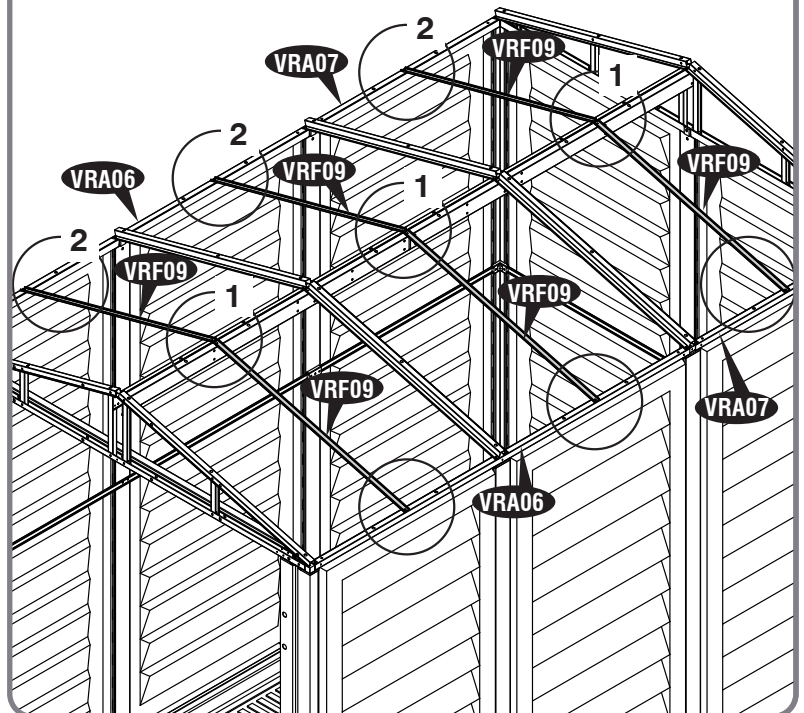

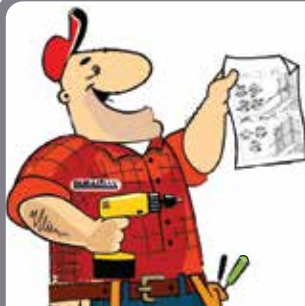

3

- | | | |
|------------------------|-------------------|------------------------|
| EN Roof Panels | CS Střešní panely | IT Pannelli del tetto |
| FR Planches de Toiture | SK Strešné panely | PL Panele dachowe |
| DE Dachplatten | SL Strešni Paneli | RO Panouri de acoperiș |
| ES Paneles de techo | HR Krovne ploče | BG Покривни панели |
| PT Painéis do Telhado | HU Tetőpanelek | TR Çatı Panelleri |
| NL Dakpanelen | SV Takpaneler | |

- | | | |
|-----------------------|-----------------------------------|-----------------------------------|
| EN Parts needed | CS Potřebné součásti | IT Parti occorrenti |
| FR Pièces nécessaires | SK Potřebné části | PL Niezbędne elementy |
| DE Benötigte Teile | SL Dele, ki jih boste potrebovali | RO Elementele componente necesare |
| ES Piezas necesitadas | HR Dijelovi potreban | BG Необходими части |
| PT Peças Necessárias | HU Szükséges részek | TR Gerekli parçalar |
| NL Onderdelen nodig | SV Delar som behövs | |

RPF1	3	PPG	40
RPF2	3	PIN	40
FPF1	1	PPGL	2
FPF2	1	PINL	2
BP	24		



- EN Use a screwdriver to align the holes.
Insert roof plugs into roof panels only as indicated.
- FR Utilisez un tournevis pour aligner les trous.
Inserez les chevilles de plastique dans les panneaux de toiture uniquement. comme indiqué.
- DE Richten Sie die Löcher mit einem Schraubendreher aus.
Setzen Sie die Dachstopfen nur wie angegeben in die Dachverkleidungen ein.
- ES Utilizar un destornillador para alinear los agujeros.
Inserte tapones de techo en paneles del techo sólo como se indica.
- PT Use uma chave de fenda para alinhar os orifícios.
Insira os bujões do telhado nos painéis do telhado apenas como indicado.
- NL Gebruik een schroevendraaier om de gaten uit te lijnen.
Plaats dakdoppen alleen in dakpanelen zoals aangegeven.
- CS Vyrovnajte otvory pomocí šroubováku.
Střešní zátky zasuněte do střešních panelů pouze tak, jak je uvedeno.
- SK Pomocou skrutkovača zarovnajate otvory.
Strešné zátky zasuněte do strešných panelov len tak, ako je uvedený.
- SL Z izvijačem poravnajte luknje.
Vstavite strešne vtiče v strešne plošče samo, kot je navedeno.
- HR Pomoću odvijača poravnajte rupe.
Umetnite krovne čepove u krovne ploče samo kako je naznačeno.
- HU Használja a csavarhúzóval a lyukakat.
A tetőcsatlakozót csak a jelzett módon tegye a tetőpanelekre.
- SV Använd en skruvmejsel för att anpassa hålen.
Sätt in takpluggarna endast i takpaneler enligt anvisningarna.
- IT Utilizzare un cacciavite per allineare i fori.
Inserire i tappi del tetto nei pannelli del tetto solo come indicato.
- PL Użyj śrubokręta, aby wyrównać otwory.
Włóżć kołki dachowe do paneli dachowych tylko tak, jak wskazano.
- RO Folosiți o șurubelniță pentru alinierea găurilor.
Introduceți dopurile de acoperiș în panourile de acoperiș numai așa cum este indicat.
- BG Използвайте отвертка, за да подравните отворите.
Поставете покривните тапи в покривните панели само както е посочено.
- TR Delikleri hizalamak için bir tornavida kullanın.
Tavan tapalarını sadece belirtildiği gibi tavan panellerine yerleştirin.



- EN Use Same color Plugs(BP).
- FR Utilisez les bouchons de même couleur (BP).
- DE Verwenden Sie die gleichen Farbstopfen (BP).
- ES Utilice tapones del mismo color (BP).
- PT Use os plugues da mesma cor (BP).
- NL Gebruik pluggen in dezelfde kleur (BP).
- CS Použijte zástrčky stejné barvy (BP).
- SK Použite zástrčky rovnakej farby (BP).
- SL Uporabite iste barvne vtiče (BP).
- HR Upotrijebite utikače iste boje (BP).
- HU Használjon azonos színű dugókat (BP).
- SV Använd samma färgpluggar (BP).
- IT Utilizzare spine dello stesso colore (BP).
- PL Użyj wtyczek tego samego koloru (BP).
- RO Folosiți fișe de aceeași culoare (BP).
- BG Използвайте едни и същи цветни щепсели (BP).
- TR Aynı renkteki Fişleri (BP) kullanın.



1

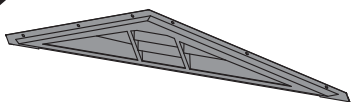

FPF1 (x1)



BP (x12)

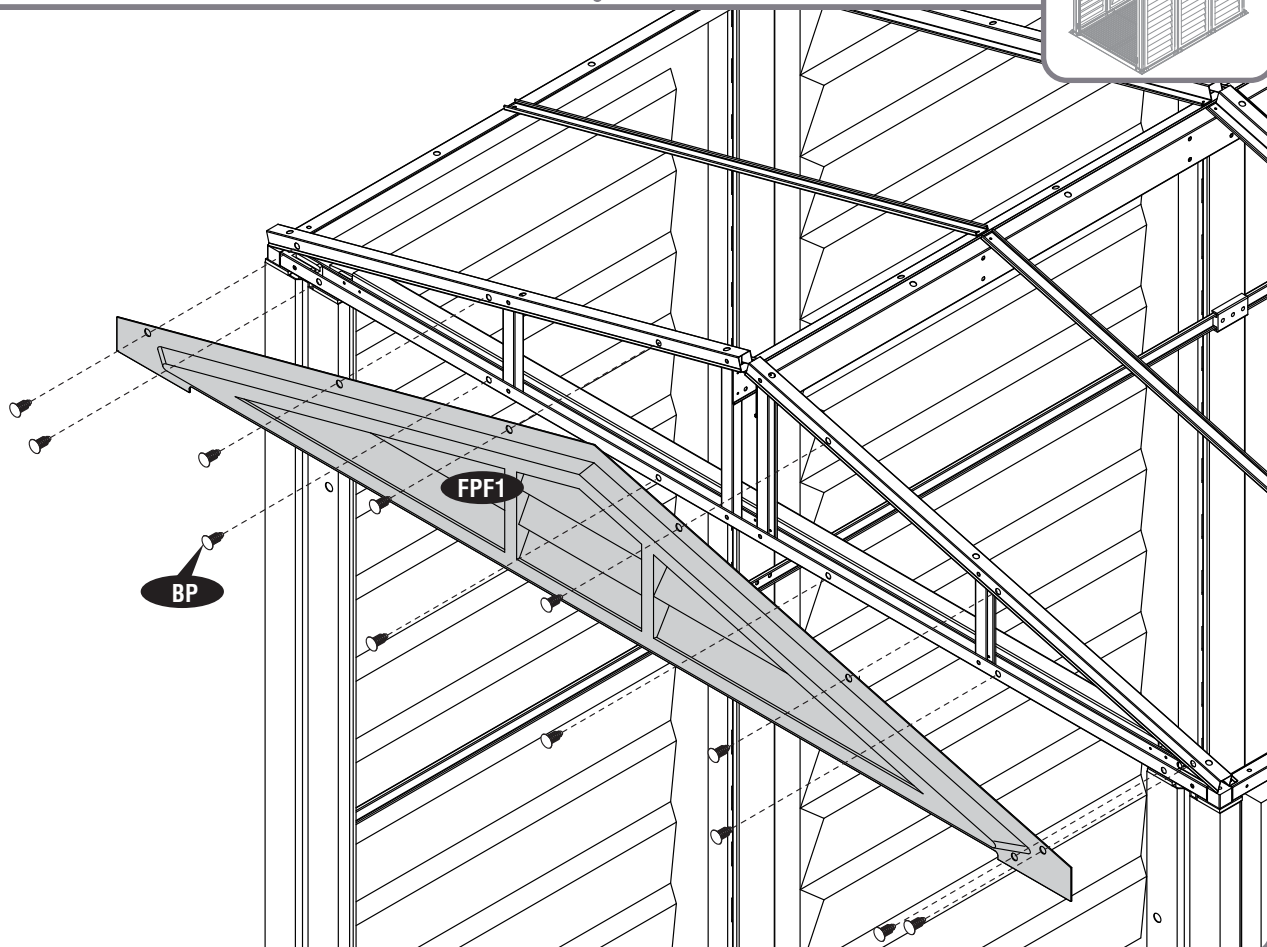
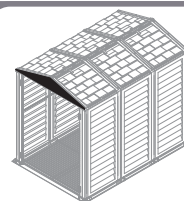

2

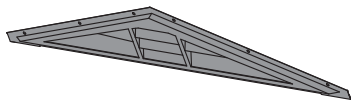

FPF2 (x1)



BP (x12)

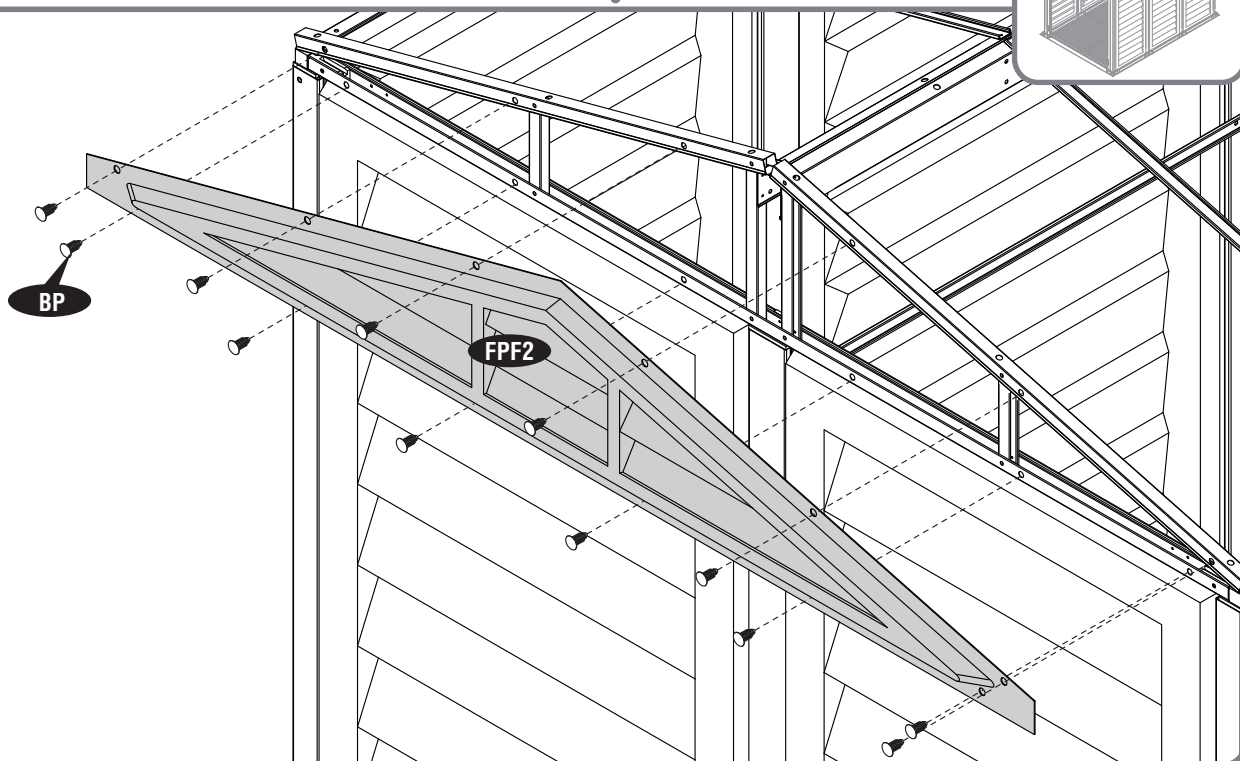
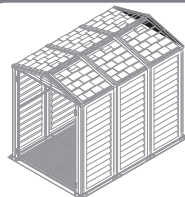

- EN** Start from front left side roof panel going back.
Apply silicone into the holes before inserting the pins (Silicone not included).
- FR** Commencez par le panneau de toit avant gauche en remontant.
Appliquez de la silicone dans les trous avant d'insérer les broches (silikon nicht enthalten).
- DE** Beginnen Sie mit der Dachverkleidung vorne links und gehen Sie zurück.
Anwenden Silikon in die Löcher vor dem Einsetzen der Stifte (Silikon nicht enthalten).
- ES** Comience desde el panel del techo frontal izquierdo hacia atrás.
Aplicar silicona en los agujeros antes de insertar los pasadores (Silicona no incluido).
- PT** Comece pelo painel do lado esquerdo do painel frontal voltando.
Aplique silicone nos orifícios antes de inserir os pinos (Silicone não incluído).
- NL** Begin vanaf het linker voorpaneel aan de achterkant.
Breng siliconen aan in de gaten voordat u de pinnen inbrengt (siliconen niet inbegrepen).
- CS** Začňte od levého předního bočního střešního panelu zpět.
Před vložením kolíků naneste silikon do otvorů (silikon není součástí balení).
- SK** Začnite od ľavého predného bočného strešného panelu smerom späť.
Pred zasunutím kolíkov naneste silikón na otvory (silikón nie je súčasťou balenia).
- SL** Začnite od sprednje leve bočne strešne plošče, ki se vrača nazaj.
Preden vstavite zatiče, v luknje nanosite silikon (Silikon ni priložen).
- HR** Krenite s prednje lijeve bočne krovne ploče prema natrag.
Nanesite silikon u rupe prije umetanja igle (Silikonski dio nije uključen).
- HU** Indítsa el a bal oldali tetőpanelt visszafelé.
A tuk behelyezése előtt szilikont kell behelyezni a lyukba (a szilikon nem tartozék).
- SV** Börja från vänster takpanel framåt gå tillbaka.
Applicera silikon i hålen innan du sätter in stiften (Silikon ingår inte).
- IT** Inizia dal pannello del tetto sul lato anteriore sinistro tornando indietro.
Applicare il silicone nei fori prima di inserire i perni (non in silicone).
- PL** Rozpocznij od lewego przedniego panelu dachowego wracając.
Nałóż silikon w otwory przed włożeniem szpilek (nie zawiera silikonu).
- RO** Începeți de la panoul acoperișului din fața din stânga, înapoi
Aplicați siliconul în găuri înainte de a introduce pini (siliconul nu este inclus).
- BG** Започнете от предния ляв страничен панел на покрива, който се връща назад.
Нанесете силикон в отворите преди да поставите щифтовете (Силиконът не е включен).
- TR** Sol ön tavan panelinden başlayarak geri dönün.
Pimleri takmadan önce deliklere silikon uygulayın (Silikon dahil değildir).

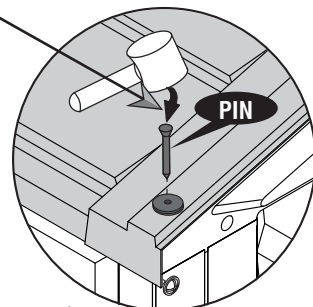
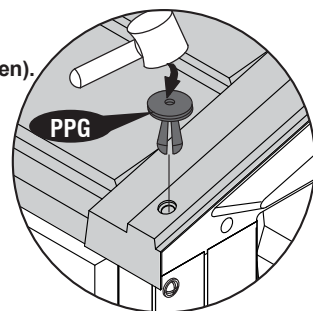

3

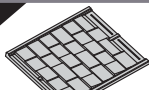

RPF1 (x1)



PPG (x4)



PIN (x4)

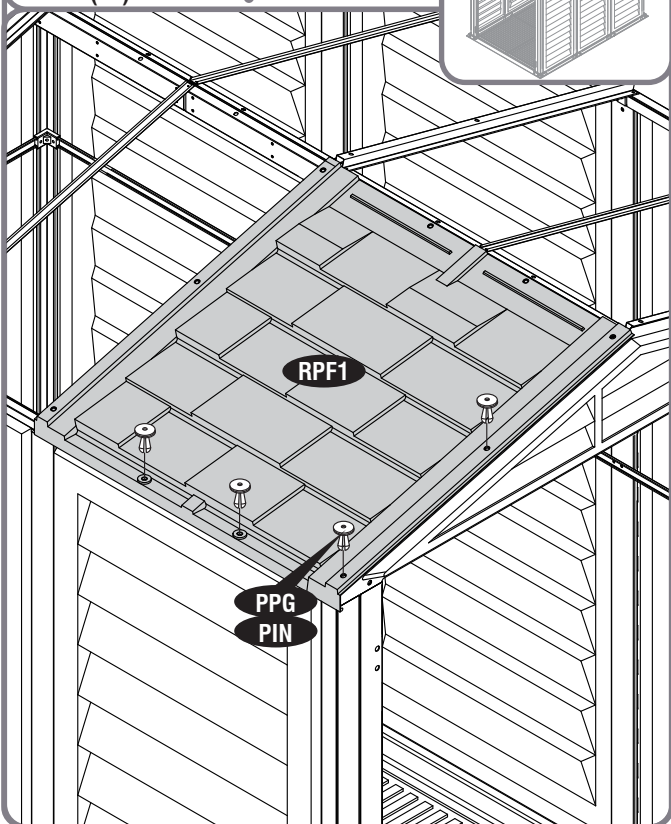
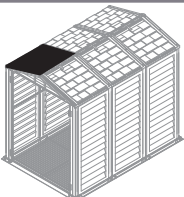

4

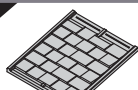

RPF1 (x1)



PPG (x4)



PIN (x4)

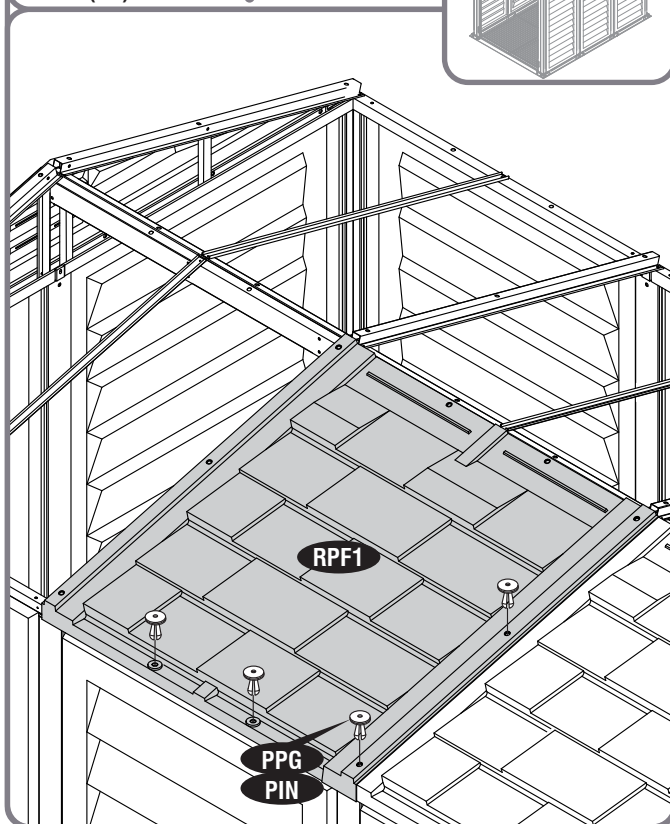
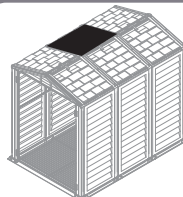

5

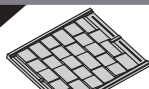

RPF1 (x1)



PPG (x6)



PIN (x6)

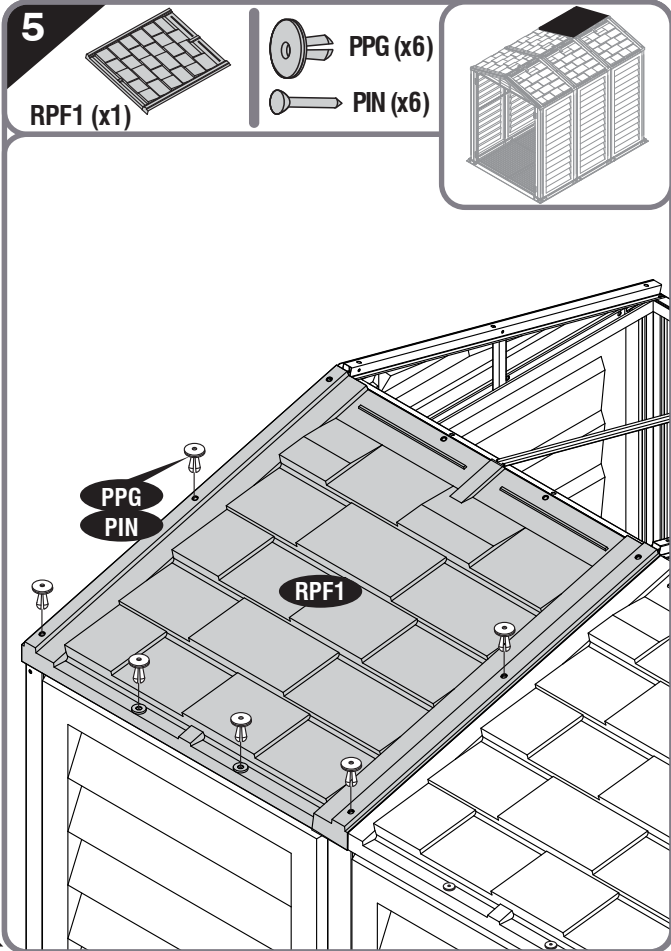
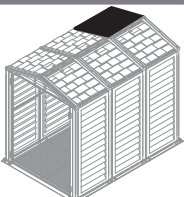

6

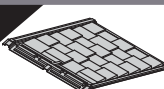

RPF2 (x1)



PPG (x8)



PIN (x8)

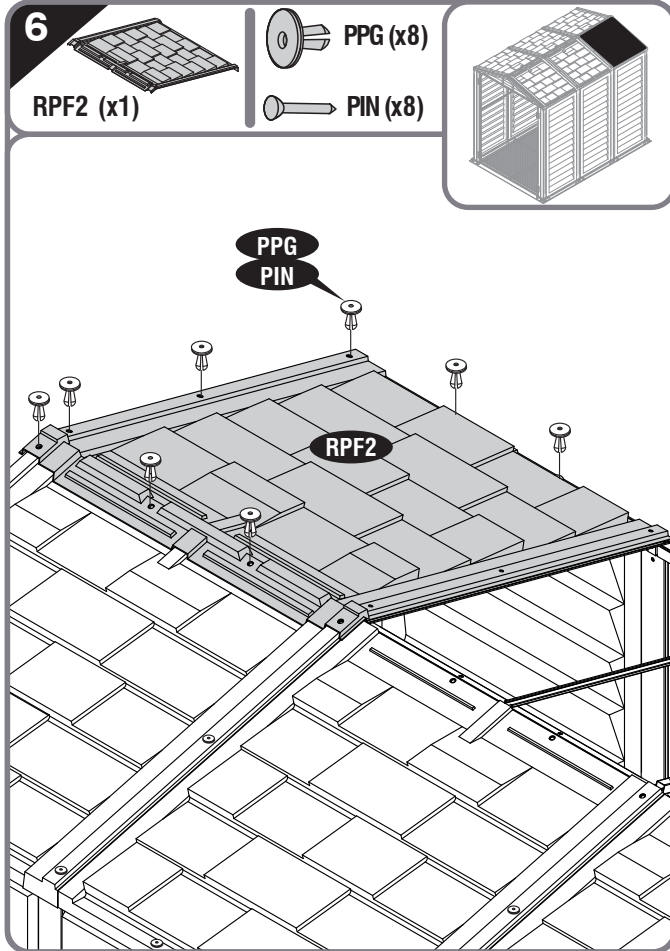
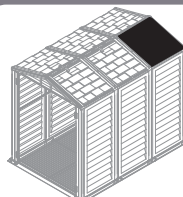

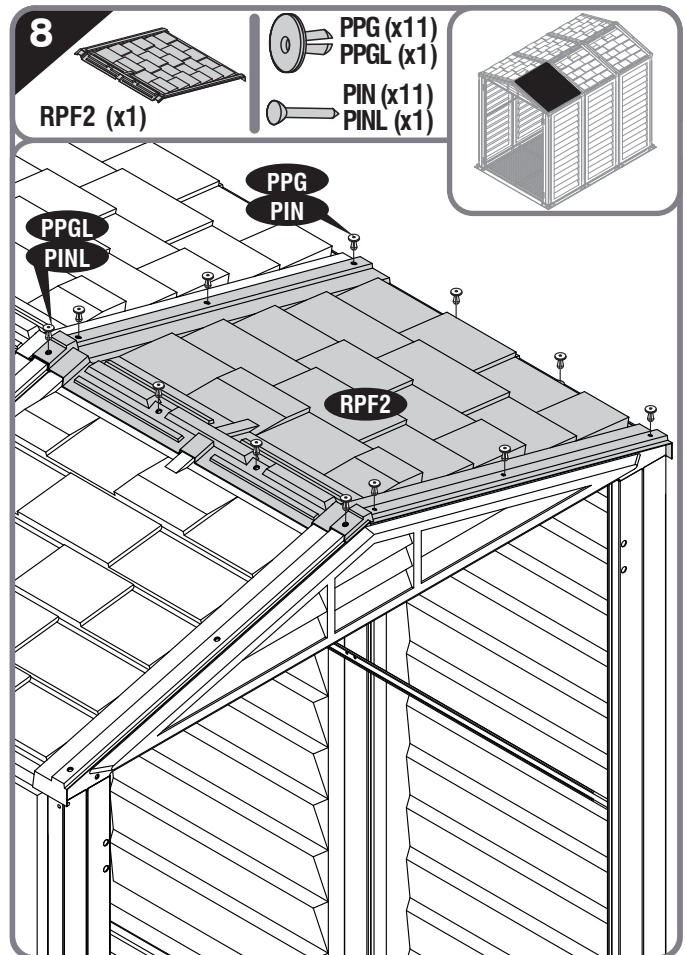
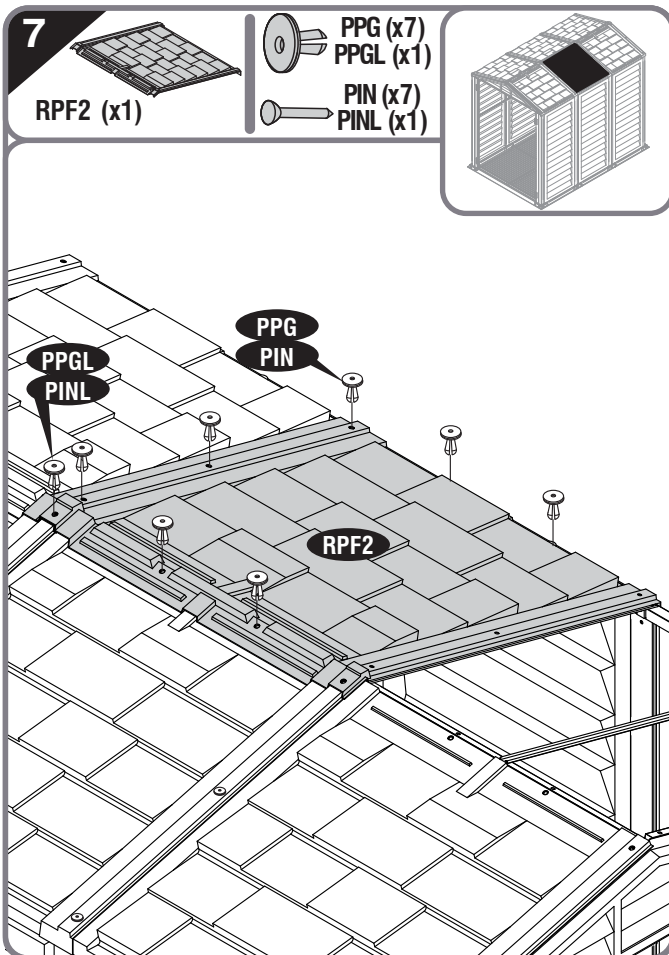

EN Apply silicone around the roof plugs. (Silicone not included).

FR Appliquez du silicone autour des bouchons de toit. (Silicone non inclus).

DE Tragen Sie Silikon um die Dachstopfen auf (Silikon nicht im Lieferumfang enthalten).

ES Aplique silicona alrededor de los tapones del techo (silicona no incluida).

PT Aplique silicone ao redor das tampas do telhado (Silicone não incluído).

NL Breng siliconen aan rond de dakpluggen. (Siliconen niet inbegrepen).

CS Okolo střešních zátek naneste silikon (silikon není součástí balení).

SK Silikón naneste na strešné zátky (silikón nie je súčasťou dodávky).

SL Okoli strešne čepe nanesite silikon (Silikon ni priložen).

HR Nanesite silikon oko krovnih čepova. (Silikon nije uključen).

HU Vigyen fel szilikonot a tetőcsavarok körül (a szilikon nem tartozék).

SV Applicera silikon runt takpropparna (silikon ingår inte).

IT Applicare silicone attorno ai tappi del tetto (silicone non incluso).

PL Nałóż silikon wokół kołków dachowych (nie zawiera silikonu).

RO Aplicați silicon în jurul dopurilor de acoperiș. (Silicon nu este inclus).

BG Нанесете силикон около тапите на покрива. (Силиконът не е включен).

TR Tavan tapalarının çevresine silikon uygulayın (Silikon dahil değildir).

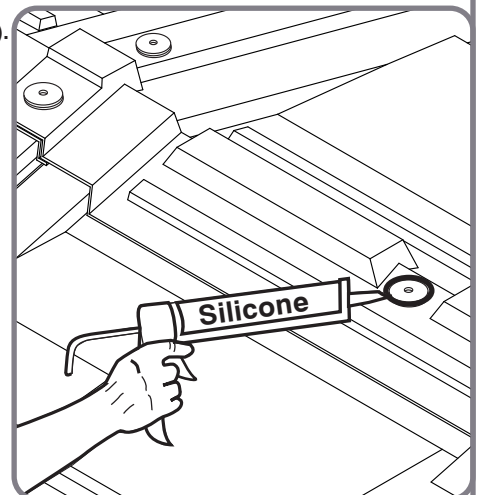



4

EN Door	CS Dveře	IT Porta
FR Porte	SK Dvere	PL Drzwi
DE Die Tür	SL Vrata	RO Ușa
ES La puerta	HR Vrata	BG Врата
PT Porta	HU Ajtó	TR Kapı
NL De deur	SV Dörr	

EN Parts needed	CS Potřebné součásti	IT Parti occorrenti
FR Pièces nécessaires	SK Potřebné části	PL Niezbędne elementy
DE Benötigte Teile	SL Dele, ki jih boste potrebovali	RO Elementele componente necesare
ES Piezas necesitadas	HR Dijelovi potreban	BG Необходими части
PT Peças Necessárias	HU Szükséges részek	TR Gerekli parçalar
NL Onderdelen nodig	SV Delar som behövs	

DLE	1
DRE	1
LH ↑	2
RH ↑	2
L	1
R	1
SGC1	20
PW	20

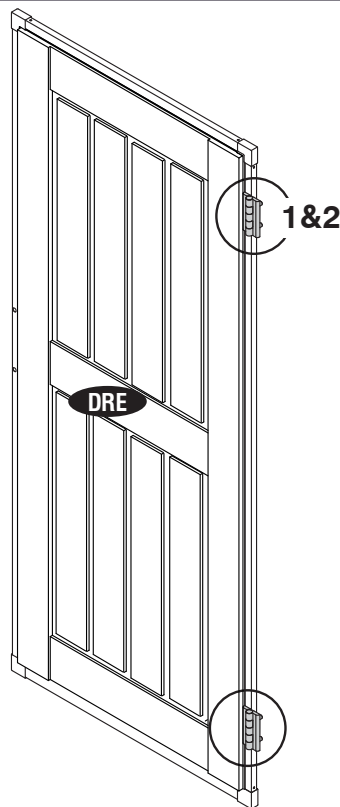
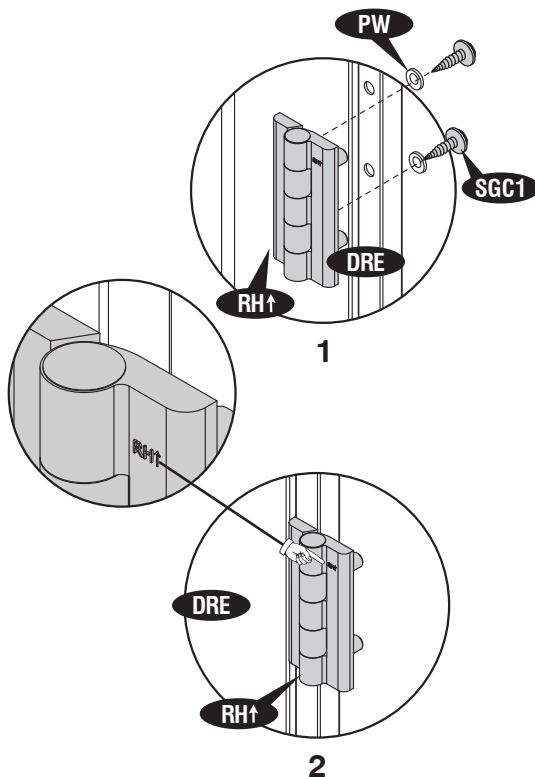
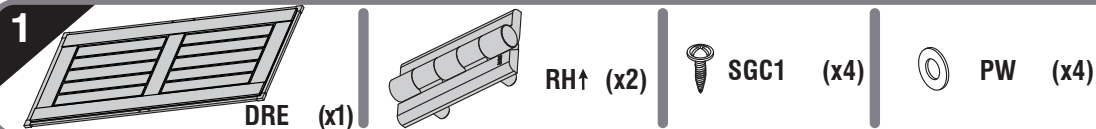

EN Right Door
FR Porte droite
DE Rechte Tür
ES Puerta derecha
PT Porta direita
NL Rechter deur
CS Právě dveře
SK Právě dvere
SL Desna vrata
HR Desna vrata
HU Jobb ajtó
SV Höger dörr
IT Porta Destra
PL Prawe drzwi
RO Usa dreapta
BG Дясна врата
TR Sağ kapı

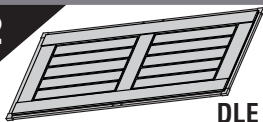
2

DLE (x1)

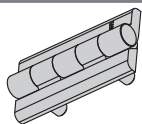

LH↑ (x2)



SGC1 (x4)



PW (x4)

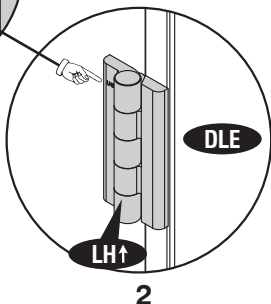
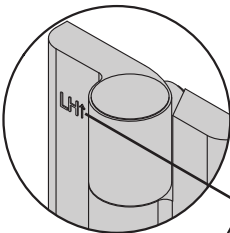
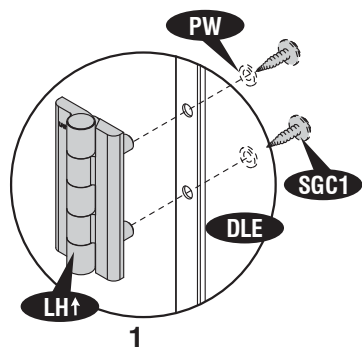
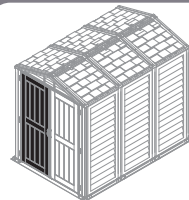

1&2

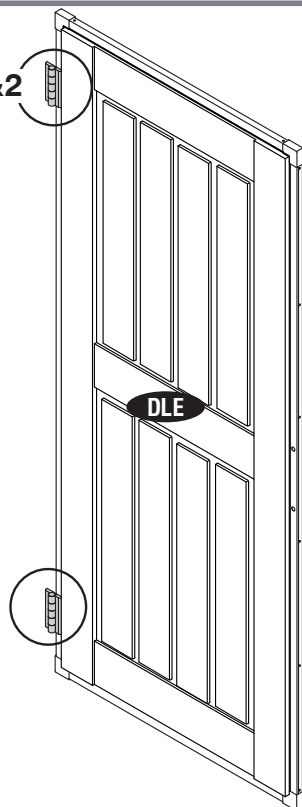

- EN Left Door
- FR Porte gauche
- DE Linke Tür
- ES Puerta izquierda
- PT Porta esquerda
- NL Linker deur
- CS Levé dveře
- SK Ľavé dvere
- SL Leva vrata
- HR Lijeva vrata
- HU Bal ajtó
- SV Vänster dörr
- IT Porta Sinistra
- PL Lewe drzwi
- RO Usa stanga
- BG Лява врата
- TR Sol kapı

**3**

SGC1 (x8)



PW (x8)

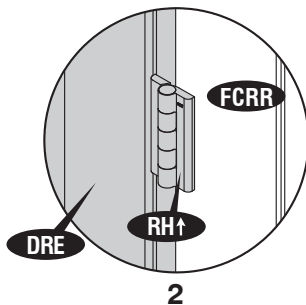
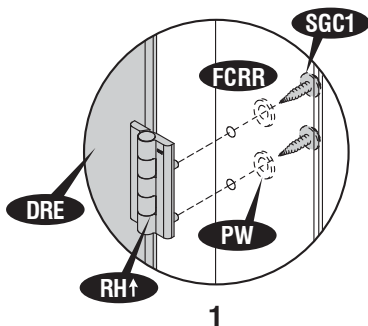
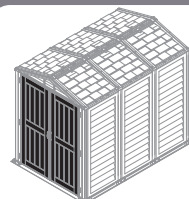

1&2

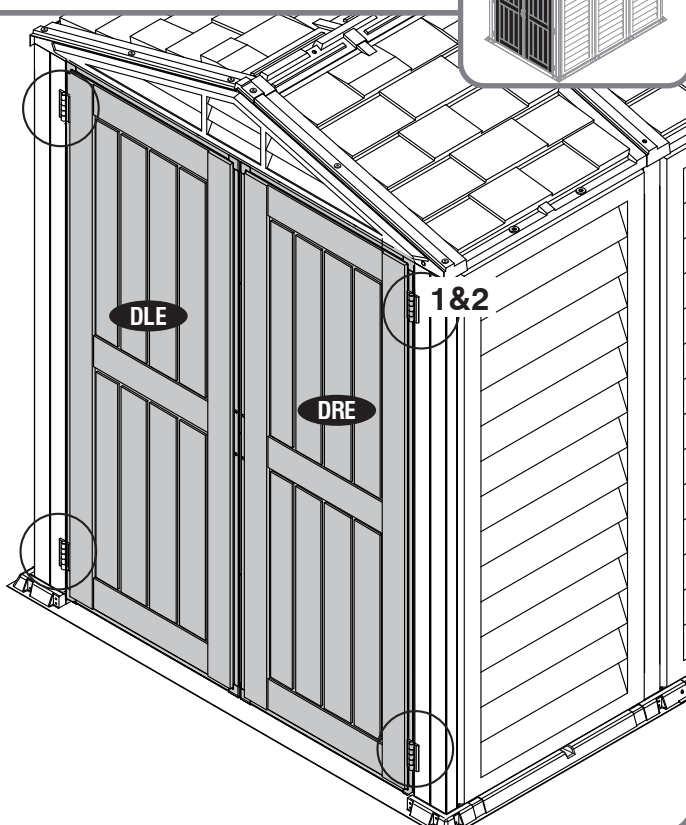

4

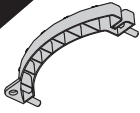

L (x1)



R (x1)



SGC1 (x4)



PW (x4)

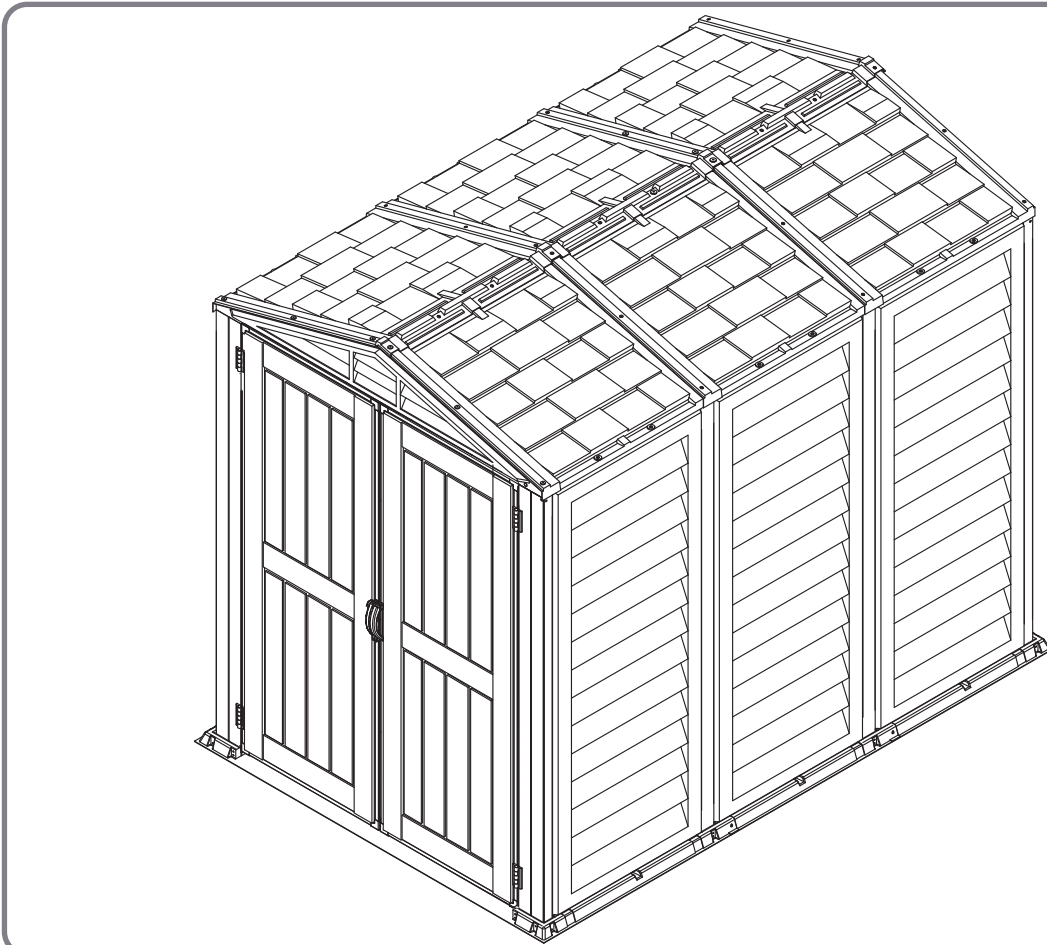
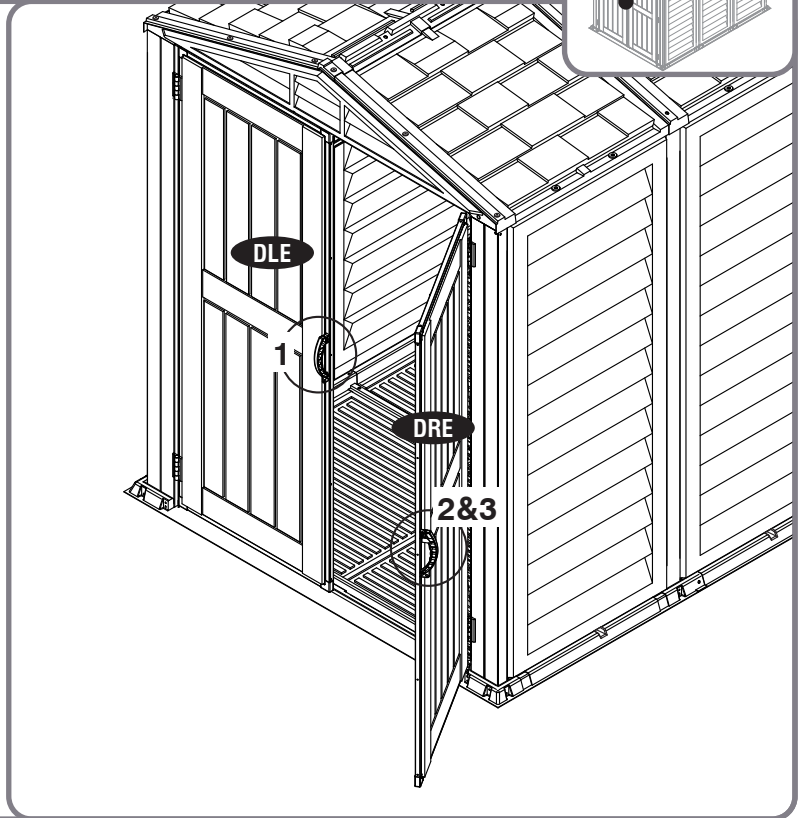
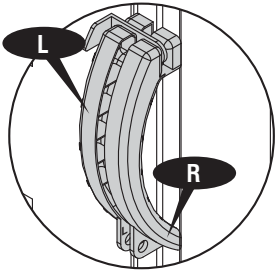
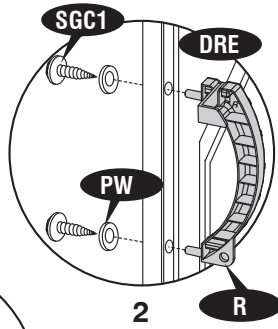
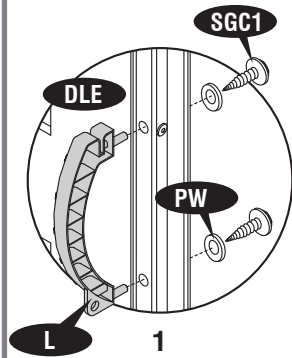
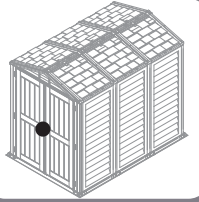

EN Assembly on Concrete Platform	CS Montáž na betonové plošině	IT Montaggio su piattaforma in calcestruzzo
FR Assemblage sur plate-forme en béton	SK Montáž na betónovú plošinu	PL Montaż na betonowej platformie
DE Montage auf Betonplattform	SL Montaža na betonsko ploščad	RO Adunarea pe platforma de beton
ES Montaje sobre la base de hormigón	HR Montaža na betonskoj platformi	BG Монтаж на бетонна платформа
PT Montagem em plataforma de concreto	HU Szerelés beton felületen	TR Beton platform üzerine montaj
NL Montage op betonplatform	SV Montering på betongplattform	



EN Parts needed	CS Potřebné součásti	IT Parti occorrenti
FR Pièces nécessaires	SK Potrebné časti	PL Niezbędne elementy
DE Benötigte Teile	SL Dele, ki jih boste potrebovali	RO Elementele componente necesare
ES Piezas necesitadas	HR Dijelovi potreban	BG Необходими части
PT Peças Necessárias	HU Szükséges részek	TR Gereklî parçalar
NL Onderdelen nodig	SV Delar som behövs	

S2	8
S6	8
F1	8



EN To ensure that your shed withstands high winds, we recommended to use this floor option. A concrete pad or a large size concrete patio stone squares is recommended for suitable floor base. Make sure it is firm and level and will allow drainage away from the site. Make a level concrete foundation, that has an outside dimension of 102 3/8" x 70 7/8" (2600mm x 1800mm).

For a concrete pad base, prepare a level bed for a firm footing layer of crushed stone. The concrete pad should then be poured to a thickness of 4 inches (100mm) to 5 inches (125mm). Allow to dry thoroughly for at least 48 hours. Manufacturer is not responsible for the choice and construction of the foundation.

Align the shed, make dia. 5.0mm holes on the base then mark the concrete through holes on the base and drill concrete with suitable concrete bit to accept Dia 6mm wall plug.

FR Pour vous assurer que votre hangar résiste à des vents violents, nous avons recommandé d'utiliser cette option de plancher. Une dalle de béton ou une grande taille concrètes dalles de patio de est recommandé pour base appropriée au sol. Assurez-vous qu'il est ferme et niveau et permettre un bon drainage du site. Faire niveau fondation en béton, qui a une dimension extérieure de 102 3/8" x 70 7/8" (2600mm x 1800mm).

Pour une dalle en béton, préparer une couche de graviers de nive au. La dalle doit faire entre 10 et 12.5 cm. Le tampon de béton doit ensuite être coulé sur une épaisseur de 4 pouces (100 mm) à 5 pouces (125 mm). Laisser sécher complètement pendant au moins 48 heures. Le fabricant n'est pas responsable du choix et de la construction des fondations.

Aligner le hangar, faire dia. 5,0mm trous sur la base puis marquer le béton à tr avers les trous sur la base et le béton de forage avec bit de béton approprié pour accepter Dia 6mm bouchon mural.

DE Um sicherzustellen, dass Ihr Schuppen hohen Winden standhält, empfiehlt es sich, diese Bodenoption zu benutzen. Dieser Geräteschuppen sollte auf einem festen Untergrund (wie zum Beispiel einer Betonfläche oder Waschbetonplatten) aufgebaut werden. Stellen Sie sicher, dass eine Entwässerung der Aufstellfläche gewährleistet ist. Erstellen sie ein ebenes Betonfundament, mit den Außenmaßen 102 3/8" x 70 7/8" (2600mm x 1800mm).

Füllen Sie eine Kiesschicht ein und verdichten Sie diese (ggf. mit einer Rüttelplatte). Giesen Sie den Beton gleichmäßig ein, die Dicke sollte 100mm bis 125mm betragen. Anschließend mindestens 48 Stunden trocknen lassen.

Der Hersteller ist nicht für die Auswahl des Fundaments verantwortlich.

Richten Sie den Schuppen aus, bohren Sie Löcher mit einem Durchmesser von 5,0 mm in die Basis und markieren Sie die Beton-Durchgangslöcher in der Basis. Bohren Sie den Beton mit einem geeigneten Betonbohrer, um einen Dübel mit einem Durchmesser von 6 mm aufzunehmen.

ES Para asegurarse de que su cobertizo resiste vientos fuertes, se recomienda utilizar esta opción baja. Un cojín concreto o los cuadrados concretos del tamaño grande de una piedra del patio se recomiendan para la base conveniente para el suelo. Asegúrese de que sea firme y llana y que permita drenaje lejos del sitio. Hacer una fundación nivel concreto que tiene una dimensión fuera de 102 3/8" x 70 7/8" (2600mm x 1800mm) cobertizo para Básico.

Para una base concreta del cojín, prepare una cama llana para una capa de pie firme de la piedra machacada. El cojín concreto se debe entonces verter a un grueso de 4 pulgadas (100mm) a 5 pulgadas (125mm). Permita secarse a fondo por lo menos 48 horas. El fabricante no es responsable de la opción y de la construcción de la fundación.

Alinear el cobertizo, hacer dia. 5.0mm agujeros en la base a continuación, marque el hormigón a través de l os agujeros en la base y taladre el hormigón con el bit de hormigón adecuado pa ra aceptar Dia 6mm tapón de pared.

PT Para garantir que o seu galpão resiste a ventos fortes, recomendamos usar esta opção de andar. Um bloco de concreto ou um quadrados de pedra de pátio de concreto de tamanho grande é recomendado para base apropriado do assoalho. Certifique-se que é firme e nivelada e permitirá drenagem longe do local. Fazer base de uma fundação de concreto nível, que tem uma dimensão exterior de 102 3/8" x 70 7/8" (2600mm x 1800mm).

Em um bloco de concreto, preparar uma cama de nível para uma camada firme de brita. O base de concreto deve ser derramado em seguida a uma espessura de 4 polegadas (100mm), 5 polegadas (125mm). Deixe para secar completamente pelo menos 48 horas. Fabricante não é responsável pela escolha e construção da Fundação.

Alinhe o galpão, faça furos com diâmetro de 5,0 mm na base e marque o concreto através dos furos na base e perfure o concreto com o bit de concreto adequado para aceitar o plugue de diâmetro de 6 mm.

NL Om ervoor te zorgen dat uw schuur bestand is tegen hoge winden, raden wij u aan deze vloeroptie te gebruiken. Een concrete pad of een groot formaat concrete patio stenen pleinen wordt aanbevolen voor geschikt woord basis. Zorg ervoor dat het is stevig en niveau en drainage zal toestaan weg van de site. Een niveau concrete stichting, die een externe dimensie van 102 3/8"x 70 7/8" (2600mm x1800mm).
 Voor betonnen blok basis, bereid een gelijke vlakke voor e en vlak ondergrondslaag van keistenen. De betonnen blok moet dan worden gegoten tot een dikte van 4 inches (100 mm) tot 5 inches (125 mm). Laat het drogen tenminste 48uren. De bouwer is niet verantwoordelijk voor de keuze van constructie van de fundering.
 Lijn het schuurtje uit, maak gaten met een diameter van 5,0 mm op de basis en markeer het beton door gaten in de basis en boor beton met een geschikte betonbeitel om een 6 mm muurplug te accepteren.

CS Abyste zajistili, že váš haly odolává silnému větru, doporučujeme použít tuto podlahu. Pro vhodnou podlahovou základnu se doporučuje betonová podložka nebo velké betonové terasové čtverce. Ujistěte se, že je pevný a rovný a umožní odvodnění od místa. Vytvořte hladký betonový podklad, který má vnější rozměr 102 3/8"x 70 7/8" (2600mm x1800mm).
 U betonové podložky připravte rovnou lůžko pro pevnou podkladovou vrstvu drčeného kamene. Betonová vložka by měla být nalita do tloušťky od 100 palců do 5 palců (125 milimetrů). Nechte důkladně vyschnout po dobu nejméně 48 hodin. Výrobce nezodpovídá za volbu a výstavbu nadace.
 Vyrovnajte kůlnu, na základně udělejte otvory o průměru 5,0 mm a poté označte betonové otvory otvory na základně a vyvrtejte beton vhodným betonovým vrtákem, aby bylo možné přijmout průměr 6mm hmoždinky.

SK Aby ste zabezpečili, že vaša haly odolá vysokému vetru, odporúčame použiť túto podlahovú možnosť. Na vhodnú podlahovú základňu sa odporúča betónová podložka alebo veľké betónové terasové kamenné štvorce. Uistite sa, že je pevný a rovný a umožní odvodnenie z miesta. Vytvorte základový betónový základ, ktorý má vonkajší rozmer 102 3/8"x 70 7/8" (2600mm x1800mm).
 Pre betónové podložky pripravte hladkú vrstvu pre pevnú základovú vrstvu drveného kameňa. Betónová podložka by mala byť potom naliata do hrúbky 4 palce (100 mm) až 5 palcov (125 mm). Nechajte dôkladne vysušiť aspoň 48 hodín. Výrobca nie je zodpovedný za výber a výstavbu nadácie.
 Zarovnajete kôľnu, na základni dajte priemer 5,0 mm a potom označte betón cez otvory na základni a vyvrtajte betón vhodným betónovým vrtákom, aby sa akceptoval priemer 6 mm hmoždinky.

SL Da bi zagotovili, da bo vaša hiša odtegnila visoke vetrove, smo priporočili, da uporabite to možnost. Za primerne talne podlage je priporočljiva betonska podloga ali betonski trgi z velikimi površinami. Prepričajte se, da je čvrsta in raven ter omogočila drenažo stran od mesta. Izdelajte ravno betonsko podlago, ki ima zunanjo dimenzijo dimenzij 102 3/8"x 70 7/8" (2600mm x1800mm).
 Za betonsko podlago pripravite ravno posteljo za trdno podlago iz drobljenega kamna. Betonsko ploščo je treba nato vliti do debeline 4 palcev (100 mm) do 5 palcev (125 mm). Pustite, da se temeljito posuši najmanj 48 ur. Proizvajalec ni odgovoren za izbiro in gradnjo temeljev.
 Poravnajte skladišče, naredite odprtine premera 5,0 mm na dnu in nato označite beton skozi luknje na dnu in zvrtejate beton z ustreznim betonским bitjem, da boste sprejeli stensko vtičnico premera 6 mm.

HR Da bismo osigurali da vaš prolaz izdrži jak vjetar, preporučujemo da upotrijebite tu podu. Za pogodnu podnu bazu preporučuje se betonska podloga ili velike kamene ploče od betona. Pobrinite se da je čvrsta i razina i omogućit će odvod daleko od stranice. Izradite temeljni betonski temelj koji ima vanjsku dimenziju od 102 3/8"x 70 7/8" (2600mm x1800mm).
 Za betonsku podlogu, pripremite krevet na razini za čvrsto podnožje slomljenog kamena. Betonsku podlogu treba zatim izliti na debljinu od 100 mm do 125 inča. Ostavite temeljito suhom najmanje 48 sati. Proizvođač nije odgovoran za odabir i izgradnju zaklade.
 Poravnajte šup, napravite rupe promjera 5,0 mm na postolju, zatim označite beton kroz rupe na bazi i izbušite beton odgovarajućim komadom betona da biste prihvatili zidni utikač promjera 6 mm.

HU Annak érdekében, hogy a fészér ellenálljon a magas szeleknek, javasoljuk, hogy használja ezt a padlót. Betonpárna vagy nagyméretű betonpadló kőpadok ajánlottak megfelelő padlóalapra. Győződjön meg arról, hogy szilárd és vízszintes, és lehetővé teszi a vízelvezetést távol a helyszíntől. Végezzünk el egy szintetikus alapot, amely 102 3/8"x 70 7/8" (2600mm x1800mm).
 Betonpárnás aljzat esetén készítsen egy szintes ágyat egy szilárd alapozórétre. A betonpárnát ezután 100 mm-es és 125 mm-es vastagságúra kell önteni. Legalább 48 órán keresztül hagyja alaposan száradni. A gyártó nem vállal felelősséget az alapítvány kiválasztásához és megépítéséért.
 Igazítsa a fészket, helyezze át az átmérőjű 5,0 mm-es lyukakat az alaplapon, majd jelölje meg a betont az alaplapon lévő lyukakon, és fúrjon be betont a megfelelő betonbevonattal, hogy elfogadja a 6 mm-es átmérőjű fali dugót.

SV För att säkerställa att din skjul tål hög vind rekommenderar vi att du använder det här golvalternativet. En betongkudde eller en stor betongplattformens stenplattor rekommenderas för lämplig golvyta. Se till att den är fast och jämn och gör det möjligt att dränera bort från platsen. Gör en jämn betongfundament, som har en yttre dimension av 102 3/8"x 70 7/8" (2600mm x1800mm).
 För en betongplatta bas, förbereda en nivå säng för ett fast fotskikt av krossad sten. Betongplattan ska sedan hällas till en tjocklek av 4 tum (100 mm) till 5 tum (125 mm). Låt torka noggrant i minst 48 timmar. Tillverkaren ansvarar inte för valet och byggandet av stiftelsen.
 Rikta ut skuren, gör hål på 5,0 mm i basen och markera betongens genomgående hål på botten och borra betong med lämplig betongbit för att ta emot 6 mm väggplugg.

IT Per garantire che il tuo capannone sopporta venti elevati, abbiamo consigliato di utilizzare questa opzione a pavimento. Si consiglia un tappetino in calcestruzzo o un quadrato in pietra di cemento in grande formato per una base adatta. Assicurarsi che sia stabile e livellato e permettere drenare lontano dal sito. Realizzare una base di calcestruzzo di livello, che ha una dimensione esterna di 102 3/8"x 70 7/8" (2600mm x1800mm).
 Per una base di rilievo in calcestruzzo, preparare un letto a livello per un solido strato di pietra schiacciata. Il tappetino di calcestruzzo deve quindi essere versato ad uno spessore da 100 mm a 125 centimetri. Lasciare asciugare accuratamente per almeno 48 ore. Il produttore non è responsabile della scelta e della costruzione della fondazione.
 Allineare il capannone, praticare fori di diametro 5,0 mm sulla base, quindi contrassegnare i fori passanti del calcestruzzo sulla base e forare il calcestruzzo con una punta di cemento adatta per accettare il tappo a muro del diametro di 6 mm.

PL Aby mieć pewność, że Twoja szopa wytrzyma silne wiatry, zalecamy skorzystanie z tej opcji podłogi. Jako odpowiednią podstawę podłogową zaleca się betonową podkładkę lub duże betonowe kwadraty tarasowe. Upewnij się, że fundament jest twardy i równy oraz umożliwia drenaż z dala od miejsc pracy. Wykonaj równy fundament betonowy o wymiarach zewnętrznych 102 3/8"x 70 7/8" (2600mm x1800mm) dla podstawowej szopy.
 W przypadku podkładki betonowej należy przygotować równe podłoże na mocną warstwę podłoża z tłucznia kamiennego. Betonową podkładkę należy następnie wylać do grubości od 4 cali (100 mm) do 5 cali (125 mm). Pozostawić do całkowitego wyschnięcia na co najmniej 48 godzin. Producent nie ponosi odpowiedzialności za wybór i budowę fundamentu.
 Wyrównaj szopę, wykonaj otwory o średnicy 5,0 mm na podstawie, a następnie zaznacz betonowe otwory w podstawie i wywierć beton odpowiednim bitem betonowym, aby przyjąć kołek ścienny o średnicy 6 mm.



RO Pentru a vă asigura că vaporul dvs. rezistă unor vânturi puternice, am recomandat să folosiți această opțiune pentru podea. Un tampon de beton sau o pătrată de piatră din beton de dimensiuni mari este recomandată pentru o bază adecvată pentru podea. Asigurați-vă că este ferm și la nivel și va permite scurgerea departe de site. Asigurați o fundație de beton de nivel, care are o dimensiune exterioară de 102 3/8" x 70 7/8" (2600mm x 1800mm). Pentru o bază de beton, pregătiți un pat de nivel pentru un strat ferm de piatră zdrobită. Plăcuța de beton trebuie apoi turnată la o grosime de 4 inci (100 mm) până la 5 inci (125 mm). Lăsați-l să se usuce bine timp de cel puțin 48 de ore. Producătorul nu este responsabil pentru alegerea și construirea fundației. Aliniați magazia, faceți diametrul de 5,0 mm pe bază, apoi marcați betonul prin orificiile de pe bază și forțați betonul cu un bit adecvat de beton pentru a accepta un diametru de 6 mm.

BG За да сте сигурни, че Вашата барака издържа високи ветрове, препоръчваме да използвате тази опция за пода. За подходяща подова основа се препоръчва използването на бетонна подложка или големи бетонни квадратни плочки. Уверете се, че тя е здрава и равна и ще позволи дренаж далеч от мястото. Направете нивелирана бетонна основа, която има външен размер от 102 3/8" x 70 7/8" (2600mm x 1800mm).

За бетон основа на подложка, подгответе ниво легло за твърда основа слой от натрошен камък. След това бетонната подложка трябва да се излива на дебелина от 4 инча (100 mm) до 5 инча (125 mm). Оставете да изсъхне напълно за поне 48 часа. Производителят не носи отговорност за избора и изграждането на основата.

Подравнете навеса, направете отвори с диаметър 5.0 mm на основата, след което маркирайте бетона през отворите на основата и пробийте бетон с подходящ бетонен бит, за да приемете щепсел с диаметър 6 mm.

TR Sundağunuzdan yüksek rüzgarlara dayanıklı olmasını sağlamak için bu zemin seçeneğini kullanmanızı öneririz. Uygun taban tabanı için beton bir yastık veya büyük boy bir beton bahçe avlusu karosu önerilir. Sert ve sağlam olduğundan ve drenajın yerinden uzaklaşmasına izin vereceğinden emin olun. Basic Shed için dış boyut 102 3/8" x 70 7/8" (2600mm x 1800mm). Beton pad taban için, ezilmiş taştan sağlam bir taban tabakası için düz bir yatak hazırlayın. Beton pedi daha sonra 4 inç (100mm) ila 5 inç (125mm) arasındaki bir kalınlığa dökülmelidir. En az 48 saat boyunca iyice kurumasına izin verin. Üretici, vakfın seçimi ve yapımı için sorumlu değildir. Kanadı hizalayın, tabanda 5.0 mm delikler açın, daha sonra tabanda delikler arasından betonu işaretleyin ve 6 mm çaplı dübel çapını kabul etmek için betonu uygun bir beton bit ile açın.



F1 (x8)



S2 (x8)



S6 (x8)

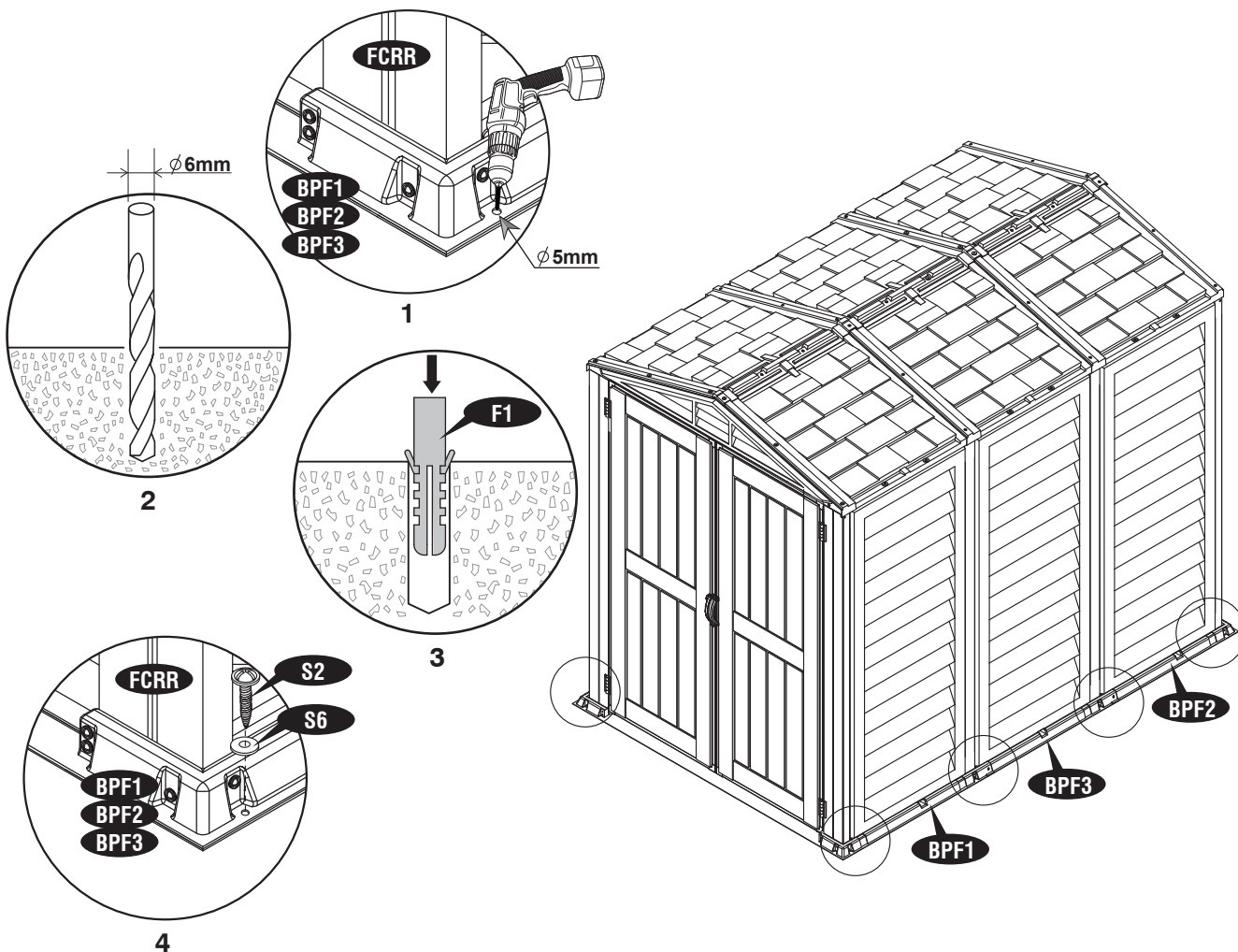

EN High wind area installation instructions	HR Visoke instalacije za instalaciju vjetra
FR Instructions pour une installation dans des zones de vent violent	HU Magas szélterületi szerelési útmutató
DE Starke Windbereiche Installationsanweisungen	SV Installationsanvisningar för hög vindområde
ES Instrucciones de instalación de la zona con fuertes vientos	IT Istruzioni per l'installazione dell'area vento forte
PT Instruções de Instalação para Áreas de Ventos Fortes	PL Instrukcja instalacji w obszarze wysokiego wiatru
NL Harde wind gebied installatie instructies	RO Instrucțiuni de instalare a zonelor eoliene
CS Instalační souprava pro oblasti se silným větrem	BG Високи инструкции за инсталиране на вятърна
SK Veľké pokyny na inštaláciu vetra	TR Yüksek rüzgar alanı kurulum talimatları
SL Navodila za montažo za območja z močnimi vetrovi	



- EN To ensure that your shed withstands high winds, you will need the following reinforcement.
- FR Pour être sûr que votre abri supportera des vents violents, vous devrez vous équiper des renforts suivants
- DE Um sicherzustellen, dass Ihr Schuppen starken Wind standhält, brauchen Sie die folgende Verstärkung.
- ES Para asegurarse de que su cubierta resiste a vientos fuertes, se necesita el siguiente refuerzo.
- PT Para garantir que seu galpão resista a ventos fortes, você precisará do seguinte reforço.
- NL Om ervoor te zorgen dat uw schuur bestand is tegen harde wind, heeft u de volgende versterking nodig.
- CS Aby bylo zajištěno, že vaše bouda odolává silnému větru, budete potřebovat následující vyztužení.
- SK Aby ste zabezpečili, že vaša haly odolá vysokým vetrom, budete potrebovať nasledovné zosilnenie.
- SL Da bi zagotovili, da bo vaša hiša trajala z močnim vetrom, boste potrebovali naslednjo ojačitev.
- HR Da bi se osiguralo da vaš prolaz izdrži jak vjetar, trebat će vam sljedeće pojačanje.
- HU Annak biztosítására, hogy a fészer ellenálljon a magas szeleknek, a következő megerősítésre lesz szüksége.
- SV För att säkerställa att dina skjul tål höga vindar behöver du följande förstärkning.
- IT Per garantire che il tuo capannone resista a forti venti, avrai bisogno del seguente rinforzo.
- PL Aby upewnić się, że twoja szopa wytrzyma silne wiatry, będziesz potrzebować następującego wzmocnienia.
- RO Pentru a vă asigura că vaporul dvs. rezistă la vânturi puternice, veți avea nevoie de armarea următoare.
- BG За да сте сигурни, че вашата барака издържа високи ветрове, ще ви трябва следната подсилване.
- TR Kulübünüzün yüksek rüzgarlara dayanmasını sağlamak için, aşağıdaki takviyeye ihtiyacınız olacaktır.



EN Parts needed (Not included)	CS Potřebné součásti (není součástí balení)	IT Parti occorrenti (non incluso)
FR Pièces nécessaires (non inclus)	SK Potrebne časti (nie je súčasťou balenia)	PL Niezbędne elementy (nie wliczone)
DE Benötigte Teile (Nicht enthalten)	SL Potrebni deli (niso vključene)	RO Elementele componente necesare (Nu este inclus)
ES Piezas necesitadas (no incluida)	HR Dijelovi potreban (nije uključeno)	BG Необходими части (не е включен)
PT Peças Necessárias (não incluído)	HU Szükséges részek (nem tartozék)	TR Gerekli parçalar (dahil değildir)
NL Onderdelen nodig (niet inbegrepen)	SV Delar som behövs (ingår ej)	

S4	Dia. 4.2 x 16mm. (5/32" x 5/8")	16



- EN** To ensure that your shed will withstand high winds, you need to anchor on the concrete foundation. Align the shed, mark the concrete at the holes in the Foundation Profiles and drill concrete with suitable concrete bit to accept Dia 6mm wall plug. (Follow the assembly step in page 54-56).
- FR** Pour vous assurer que votre hangar va résister aux vents violents, il fallait ancrer sur le foundation. Align béton du hangar, marquer le béton au niveau des trous dans les profils de fondation et forage de béton avec foret à béton adapté à accepter diamètre prise murale de 6 mm. (Suivez l'étape d'assemblage en pages 54-56).
- DE** Um sicherzustellen, dass Ihr Schuppen starken Winden widerstehen kann, müssen Sie auf dem Betonfundament verankern. Richten Sie den Schuppen aus, markieren Sie den Beton an den Löchern in den Fundamentprofilen und bohren Sie Beton mit geeignetem Betonstück, um den 6 mm Wanddübel zu akzeptieren. (Folgen Sie dem Montageschritt auf Seite 54-56).
- ES** Para asegurarse de que su caseta puede soportar fuertes vientos, es necesario anclar a la base de hormigón. Alinee el cobertizo, marque en el hormigón la marca para hacer los agujeros de los perfiles de cimentación y taladre el hormigón con broca adecuada 6mm (Sigue la etapa de montaje en la página 54-56).
- PT** Para garantir que seu galpão irá suportar ventos fortes, você precisa ancorar na fundação de concreto. Alinhe o galpão, marque o concreto nos orifícios dos perfis de fundação e perfure o concreto com o bit de concreto adequado para aceitar o plugue de parede de diâmetro de 6 mm. (Siga o passo de montagem na página 54-56)
- NL** Om ervoor te zorgen dat uw schuur bestand is tegen harde wind, moet u op de betonnen fundering steunen. Lijn de schuur uit, markeer het beton op de gaten in de funderingsprofielen en boor beton met een geschikte betonstaal om de 6 mm-muurplug van Dia te bevestigen. (Volg de montagestep op pagina 54-56).
- CS** Aby bylo zajištěno, že vaše bouda odolá vysokým větrům, je třeba kotvitě na betonovém podkladu. Připojte kůlnu, vyznačte beton v dírách v profilech základové vrstvy a vrtáním betonu vhodným betonovým břitem, abyste přijali zásuvku se zásuvkou Dia 6mm. (Postupujte podle kroku sestavení na straně 54-56).
- SK** Aby ste zabezpečili, že vaša budova bude odolávať vysokému vetru, musíte zakotviť na betónovom podklade. Pripevniť kôlnu, označiť betón v otvoroch základových profilov a vyvrtávať betón s vhodným betónovým bičom, aby ste prijímali nástennú zátku Dia 6 mm. (Postupujte podľa kroku montáže na strane 54-56).
- SL** Da bi zagotovili, da bo vaša hiša vzdržala visoke vetrove, morate sidrati na betonskem temelju. Potegnite vrelo, označite beton na luknjah v temeljnih profilih in izvrtajte beton z ustreznim betonom, da sprejmete vtičnico Dia 6mm. (Sledite korak montaže na strani 54-56).
- HR** Kako bi se osiguralo da će vaš prolaz izdržati visoke vjetrove, morate se sidriti na betonskoj podlozi. Pričvrstite prolivenu ploču, označite beton na rupama u profilima podloge i izbušite beton s odgovarajućim betonskim zupčanjem da biste prihvatili zidni utikač Dia 6 mm. (Slijedite korak montaže na stranici 54-56).
- HU** Annak érdekében, hogy a fészér ellenálljon a magas szélnek, meg kell horgonni a beton alapon. Align a fészér, jelölje a beton az lyukak az alapítvány profilok és fúrni beton megfelelő beton bit elfogadni Dia 6 mm-es fali dugó. (Kövessen a szerelési lépést az 54-56. oldalon).
- SV** För att säkerställa att ditt skjul tål höga vindar, måste du ankre på betongfundamentet. Passa skuren, markera betongen i hålen i stiftprofilerna och borra betong med lämplig betongbit för att ta emot Dia 6mm väggkontakt. (Följ monteringssteget på sidan 54-56).
- IT** Per garantire che il tuo capannone resista a forti venti, è necessario ancorare sulle fondamenta in calcestruzzo. Allineare il capannone, contrassegnare il cemento nei fori dei profili di fondazione e forare il calcestruzzo con una punta di cemento adatta per accettare il tappo a muro da 6 mm. (Seguire la fase di assemblaggio a pagina 54-56).
- PL** Aby mieć pewność, że szopa wytrzyma silne wiatry, musisz zakotwić ją na betonowym fundamencie. Wyrównaj szopę, zaznacz otwory na betonie przez profile fundamentowe, następnie wywierć beton odpowiednim wiertłem do betonu, pasującym do kołków rozporowych o średnicy 6 mm. (Wykonaj etap montażu na stronach 54-56).
- RO** Pentru a vă asigura că vaporul dvs. va rezista la vânturi puternice, trebuie să vă ancorați pe fundația de beton. Alinați șopronul, marcați betonul în găurile din Profilele de fundație și forțați betonul cu un șurub de beton adecvat pentru a acționa fișa de perete Dia 6mm. (Urmați pașii de asamblare de la pagina 54-56).
- BG** За да сте сигурни, че вашата барака ще издържи на силни ветрове, трябва да закрепите на бетонната основа. Направете заграждението, маркирайте бетона в отворите в профилите на основата и пробийте бетон с подходящ бетон, за да приемиете 6 мм стена. (Следвайте стъпката за монтаж на стр. 54-56).
- TR** Kulübünüzün yüksek rüzgara dayanacağından emin olmak için, beton temel üzerine demirlemeniz gerekir. Döşemeyi hizalayın, Betonu Temel Profillerdeki deliklerden işaretleyin ve Dia 6mm duvar fişini kabul etmek için betonu uygun bir beton ile delin. (Sayfa 54-56'teki montaj adımı izleyin).

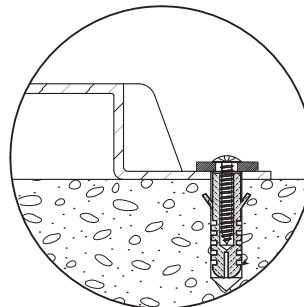



- EN** Attach each Side Panel (WPE1↑) on top to the Roof Structure (VRF01,VRA06,VRA07). Using a dia. 3mm (1/8") drill with a power drill, make two equal distance holes on the Side Panel through the Roof Structure. Drive a self tapping screw (S4) through the Side Panel to the Roof Structure. Repeat this for every Side Panel. See blowup.
- FR** Fixez chaque panneau latéral (WPE1↑) au-dessus de la structure de toit (VRF01,VRA06,VRA07). Avec un foret de 3 mm (1/8") et une perceuse électrique, percez deux trous à égale distance sur le panneau latéral dans la structure de toit. Insérez une vis autotaraudeuse (S4) à travers le panneau latéral dans la structure de toit. Répétez cette opération avec chaque panneau latéral. Voir l'agrandissement.
- DE** Befestigen Sie jede Seitenwand (WPE1↑) oben an der Dachstruktur (VRF01,VRA06,VRA07). Mit einem dia. 3mm (1/8 ") bohren mit einer Bohrmaschine, machen Sie zwei Löcher mit gleichem Abstand auf der Seitenplatte durch die Dachkonstruktion. Fahren Sie eine selbstschneidende Schraube (S4) durch die Seitenwand zur Dachkonstruktion. Wiederholen Sie dies für jedes Side Panel. Siehe Vergrößerung.
- ES** Fije cada panel lateral (WPE1↑) en la parte superior de la estructura del tejado (VRF01,VRA06,VRA07). Usando un día. 3 mm (1/8 ") perforo con un taladro eléctrico, hacer dos agujeros a la misma distancia en el panel lateral a través de la estructura del techo. Introduzca un tornillo auto-roscante (S4) a través del panel lateral a la estructura del techo. Repita esto para cada panel lateral. Ver ampliación.
- PT** Posicione cada painel lateral (WPE1↑) na parte superior da estrutura de telhado (VRF01,VRA06,VRA07). Usando uma furadeira 3mm (1/8") de alto desempenho, fazer dois furos igual distância do painel lateral por meio da estrutura do telhado. Dirigir um parafuso auto escutas (S4) através do painel lateral para a estrutura do telhado. Repita o processo para cada painel lateral. Veja ampliar.
- NL** Bevestigt de zijpanelen (WPE1↑) geplaatst aan de dakconstructie (VRF01,VRA06,VRA07). Met een diameter 3mm(1/8") boor, maak met een boormachine twee soortgelijke gaatjes op de Basis "U" kanaal via het zijpaneel. Zet een zelftappende schroef (S4) door de Basis "U" kanaal om het zijpaneel te bevestigen. Herhaal dit voor elke zijpaneel. Zie blowup.
- CS** Připojte každý boční panel (WPE1↑) na vrcholu na střešní konstrukci (VRF01,VRA06,VRA07). Použitím prům. 3mm (1/8") vrtáku s vrtáčkou, udělat dvě stejné vzdálenosti děr na bočním panelu přes střešní konstrukci. Zavřete samořezný šroub (S4) přes postranním panelu na střešní konstrukci . Tento postup opakujte pro každý boční panel. Viz blowup.
- SK** Pripojte každý bočný panel (WPE1↑) hore na konštrukciu strechy (VRF01,VRA06,VRA07). Pomocou dia. Vrtáčka 3 mm (1/8 ") s výkonným vrtákom vytvára dva bočné otvory na bočnom paneli cez strešnú konštrukciu. Pohnite samořeznú skrutku (S4) cez bočný panel k strešnej konštrukcii. Zopakujte to pre každý bočný panel. Pozri fúkanie.
- SL** Pritrdite posamezni Stranski Panel (WPE1↑) na vrhu na strešno konstrukcijo (VRF01,VRA06,VRA07). Z uporabo 3mm (1/8") vrtanja z vrtalnim strojem, narediti dve luknji enake razdalje na stranski plošči skozi strešno konstrukcijo. Pričvrstite samovrezni vijak (S4) skozi stranski plošči na strešno konstrukcijo. To ponovite za vsako stranico. Oglejte si povečavo.
- HR** Pričvrstite svaku bočnu ploču (WPE1 ↑) na vrh na krovnu strukturu (VRF01,VRA06,VRA07). Korištenje dijaprojeksije. Izbušite 3 mm (1/8 inča) bušilicom za snagu i napravite dvije rupe za jednake udaljenosti na bočnoj ploči kroz krovnu strukturu. Vozite vijak za samolijepljivanje (S4) kroz bočnu ploču na krovnu strukturu. Ponovite ovo za svaku bočnu ploču. Pogledajte blowup.
- HU** Csatlakoztassa a tetőszerkezethez tartozó minden oldallapot (WPE1↑) tetejére (VRF01,VRA06,VRA07). Dia. 3 mm-es (1/8 ") fúrógépet fúróval, készítsen két egyenlő távolságot az oldallapon a tetőszerkezeten keresztül. Hajtsa be az önmetsző csavart (S4) az oldalsó panelen keresztül a tetőszerkezethez. Ezt ismétlje meg minden oldallaphoz. Lásd a fűjást.
- SV** Fäst varje sidopanel (WPE1↑) ovanpå takkonstruktionen (VRF01,VRA06,VRA07). Använda en bild 3 mm (1/8 ") borrh med en kraftborr, gör två lika distanshål på sidopanelen genom takstrukturen. Kör en självtagsskruv (S4) genom sidopanelen till takstrukturen. Upprepa detta för varje sidopanel. Se uppblåsning.
- IT** Attaccare ciascun pannello laterale (WPE1↑) in cima alla struttura del tetto (VRF01,VRA06,VRA07). Utilizzando un dia. Trapano da 3mm (1/8 ") con trapano elettrico, creare due fori uguali per la distanza sul pannello laterale attraverso la struttura del tetto. Guidare una vite autofilettante (S4) attraverso il pannello laterale fino alla struttura del tetto. Ripeti questo per ogni pannello laterale. Vedi l'ingrandimento.
- PL** Przymocuj każdy panel boczny (WPE1 ↑) na dole do profilu U (VRF01,VRA06,VRA07) . Za pomocą wiertła śr. 3mm (1/8 ") wykonaj dwa otwory o równej odległości w profilu U (ceownik) podstawy przez panel boczny. Wkręć wkręt samogwintujący (S4) przez podstawę ceownika do panelu bocznego. Powtórz to dla każdego panelu bocznego. Zobacz powiększenie.
- RO** Ataşaţi fiecare panou lateral (WPE1↑) deasupra structurii acoperişului (VRF01,VRA06,VRA07). Folosind dia. 3 mm (1/8 ") cu un burghiu de foraj, faceti doua gauri de distanta egale pe panoul lateral prin structura de acoperis. Conduceţi un şurub de autoapăsare (S4) prin panoul lateral la structura acoperişului. Repetaţi acest lucru pentru fiecare panou lateral. Vezi lovitura.
- BG** Прикрепете всеки страничен панел (WPE1↑) нагоре към конструкцията на покрива (VRF01,VRA06,VRA07). Използвайте ди. 3 мм (1/8 ") тренировка с мощност пробиване, направи две равни отвори дистанция на страничния панел през покривната конструкция. Задвижете винт (S4) чрез страничния панел към конструкцията на покрива. Повторете това за всеки страничен панел. Вижете издуването.
- TR** Her bir Yan Paneli (WPE1↑) üstünü Çatı Yapısına (VRF01,VRA06,VRA07) takın. Bir dia kullanma 3 mm (1/8 ") matkapla delin, Yan Panelde Çatı Yapısı ile iki eşit mesafe deliği yapın. Yan Panelden Çatı Yapısına bir kendinden kılavuzlu vida (S4) sürün. Her bir Yan Panel için bunu tekrarlayın. Patlama bakın.a



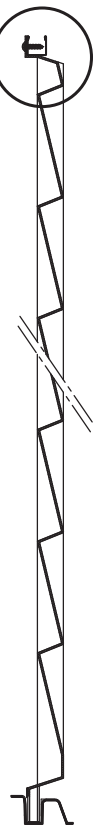
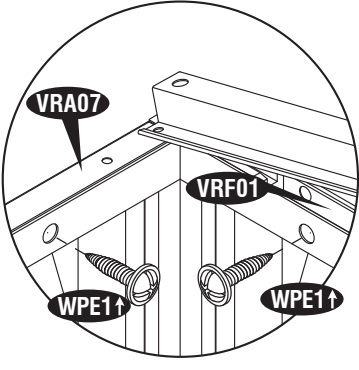
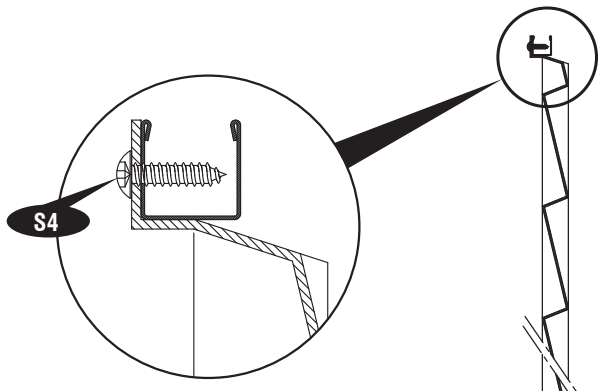
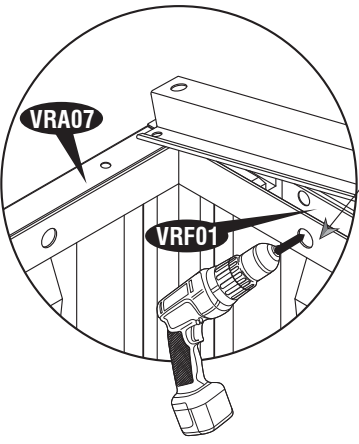
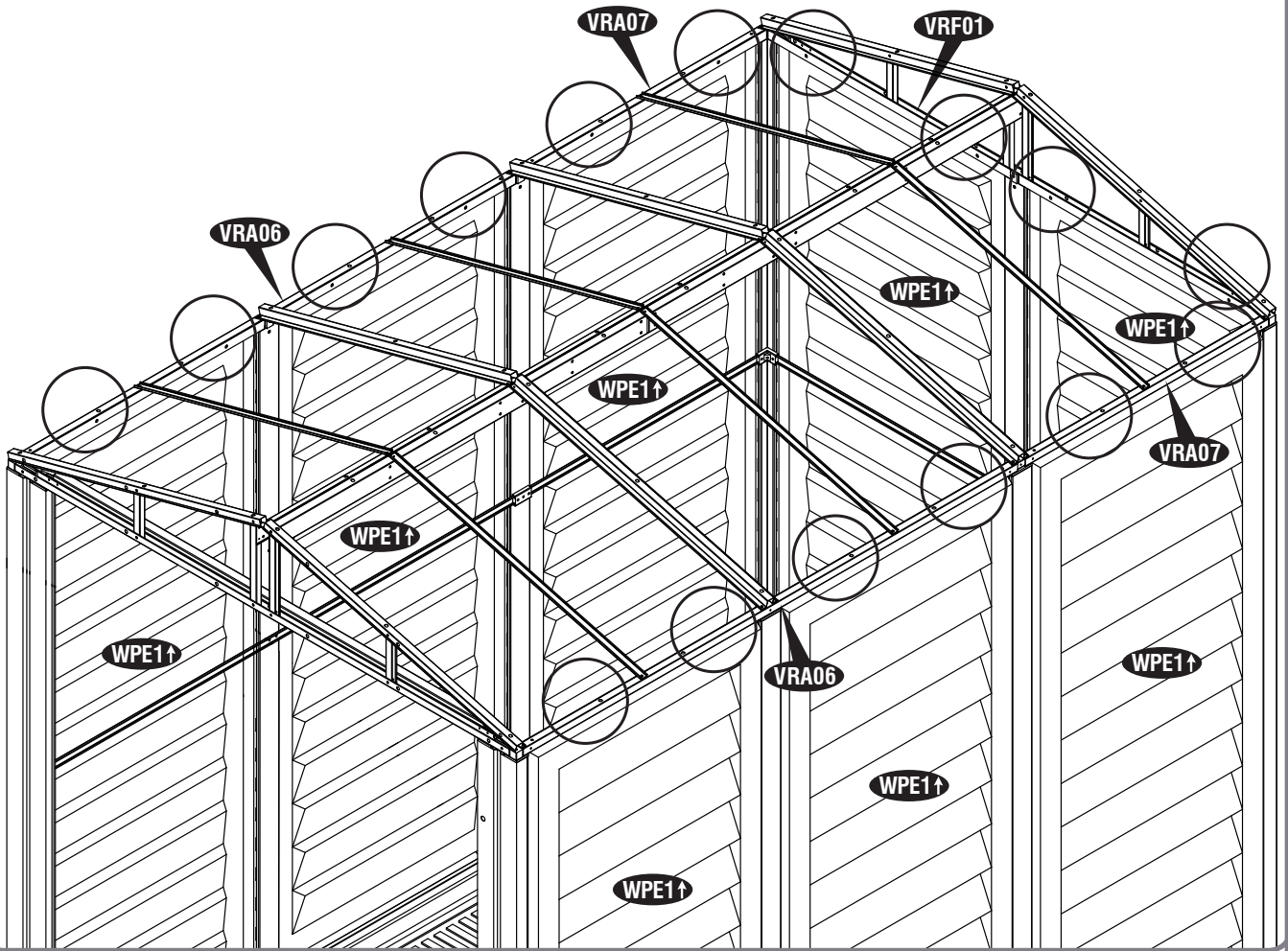

EN Important Warranty Information

FR Informations Importantes Concernant La Garantie

DE Wichtige Informationen zur Gewährleistung

ES Información importante sobre la garantía

PT Importantes Informações de Garantia

NL Belangrijke Informatie over de garantie

CS Důležitá informace o záruce

SK Dôležitá informácie o záruke

SL Pomembne Garancijske Informacije

HR Važne informacije o jamstvu

HU Fontos jótállási információk

SV Viktig garantiinformation

IT Informazioni importanti sulla garanzia

PL Ważne informacje gwarancyjne

RO Informații importante privind garanția

BG Важна информация за гаранцията

TR Önemli Garanti Bilgileri



EN The 'DURAMAX' shed has been tested and passed high wind loads in a controlled laboratory environment when installed with the high wind installation guidelines. Natural high wind areas create wind at unpredictable speeds that are very difficult to capture accurately by location. As such we cannot guarantee the performance of the shed in these extreme situations

FR Le hangar 'DURAMAX' a été testé et passé des charges de vent élevées dans un environnement de laboratoire contrôlé lorsqu'il est installé avec les directives d'installation de haute vent. Naturelles, les zones de vents forts créent vent à des vitesses imprévisibles qui sont très difficiles à saisir avec précision par emplacement. En tant que tel, nous ne pouvons pas garantir la performance de la foule dans ces situations.

DE Das "DURAMAX" -Haus wurde getestet und hat hohe Windlasten in einer kontrollierten Laborumgebung bestanden, wenn es mit den Richtlinien für hohe Windinstallationen installiert wurde. Natürliche Starkwindgebiete erzeugen Wind mit unvorhersehbaren Geschwindigkeiten, die aufgrund des Standorts nur schwer erfasst werden können. Daher können wir die Leistung des Schuppens in diesen extremen Situationen nicht garantieren.

ES La caseta 'DURAMAX' ha sido probada y aprobado para cargas de viento en un entorno controlado de laboratorio, cuando se instala con las pautas de instalación de vientos fuertes. Espacios naturales de vientos crean viento a velocidades impredecibles que son muy difíciles de capturar con precisión la ubicación. Por lo tanto, no podemos garantizar el correcto funcionamiento de la caseta en tales situaciones extremas.

PT O galpão 'DURAMAX' foi testado e passou por altas cargas de vento em um ambiente de laboratório controlado quando instalado com as diretrizes de instalação de alta energia eólica. As áreas naturais de ventos fortes criam vento a velocidades imprevisíveis que são muito difíceis de capturar com precisão por localização. Como tal, não podemos garantir o desempenho do galpão nessas situações extremas

NL Het 'DURAMAX'-schuurtje is getest en heeft hoge windbelastingen doorstaan in een gecontroleerde laboratoriumomgeving, indien geïnstalleerd met de richtlijnen voor hoge winden. Natuurlijke windrijke gebieden creëren wind met onvoorspelbare snelheden die zeer moeilijk nauwkeurig op locatie kunnen worden vastgelegd. Als zodanig kunnen we de prestaties van de schuur in deze extreme situaties niet garanderen

CS Ústředna DURAMAX byla testována a prošla vysokým zatížením větrem v kontrolovaném laboratorním prostředí, když byla instalována s pokyny pro větrnou instalaci. Přirozené větrné plochy vytvářejí vítr při nepředvídatelných rychlostech, které je velmi obtížné přesně zachytit podle místa. Jako takové nemůžeme zaručit výkon haly v těchto extrémních situacích

SK Dúchadlá "DURAMAX" boli testované a prešli vysokou záťažou vetra v kontrolovanom laboratórnom prostredí, keď sú inštalované so smernicami pre vysoký vietor. Prírodné oblasti s vysokým vetrom vytvárajú vietor pri nepredvídateľných rýchlostiach, ktoré sa veľmi ťažko zachytia presne podľa miesta. Ako taký nemôžeme zaručiť výkonnosť kólne v týchto extrémnych situáciách

SL Preskus "DURAMAX" je bil preizkušeni in prešel velike obremenitve vetra v nadzorovanem laboratorijskem okolju, če je bil nameščen s smernicami za visoko vetrove. Naravni viri vetra ustvarijo veter ob nepredvidljivih hitrostih, ki jih je zelo težko natančno zajemati glede na lokacijo. Kot taka ne moremo zagotoviti učinkovitosti skladišča v teh skrajnih razmerah

HR Prostor "DURAMAX" je testiran i prošao velike opterećenja vjetrom u kontroliranom laboratorijskom okruženju kada je instaliran s visokim smjernicama za instalaciju vjetra. Prirodni visoki vjetrojevi stvaraju vjetar na nepredvidljivim brzinama koje su vrlo teško točno snimiti po lokaciji. Kao takav ne možemo jamčiti izvedbu prolivenih u ovim ekstremnim situacijama

HU A DURAMAX fészerét ellenőrzött laboratóriumok környezetben tesztelték, és nagy szélterhelést vezettek be, amikor a nagy szélszélkapási irányelvekkel telepítették. A természeti nagy szélterületek olyan kiszámíthatatlan sebességű szélszélkapást hoznak létre, amelyet nagyon nehéz rögzíteni helyesen a helyszínen. Így nem garantálhatjuk a fészer teljesítményét ebben a szélszélkapás helyzetben

SV DURAMAX-skjulet har testats och passerat höga vindbelastningar i en kontrollerad laboratoriemiljö när den installerats med riktlinjerna för hög vindkraft. Naturliga höga vindområden skapar vind med oförutsägbara hastigheter som är mycket svåra att fånga noggrant på plats. Som sådan kan vi inte garantera skurets prestanda i dessa extrema situationer

IT Il capannone 'DURAMAX' è stato testato e ha superato carichi di vento elevato in un ambiente di laboratorio controllato quando installato con le linee guida per l'installazione del vento forte. Le aree naturali del vento forte creano vento a velocità imprevedibili che sono molto difficili da catturare con precisione in base alla posizione. Pertanto non possiamo garantire le prestazioni del capannone in queste situazioni estreme





- PL** Szopa "DURAMAX" została przetestowana i przeszła duże obciążenia wiatrem w kontrolowanym środowisku laboratoryjnym, gdy zainstalowano ją zgodnie z wytycznymi dotyczącymi instalacji wiatrowej. Naturalne obszary o dużym natężeniu wiatru wytwarzają wiatr o nieprzewidywalnych prędkościach, które są bardzo trudne do uchwycenia dokładnie według lokalizacji. W związku z tym nie możemy zagwarantować wykonania szopy w tych ekstremalnych sytuacjach.
- RO** Dulapul "DURAMAX" a fost testat și a fost încercat cu încercături puternice de vânt într-un mediu de laborator controlat atunci când este instalat cu instrucțiunile de instalare a vântului. Zonele naturale cu vânt puternic creează vânt la viteze imprevizibile, care sunt foarte greu de capturat cu precizie în funcție de locație. Ca atare, nu putem garanta performanța magazinului în aceste situații extreme
- BG** Тръбопроводът "DURAMAX" е тестван и преминава в силно натоварване от вятър в контролирана лабораторна среда, когато е инсталиран с насоките за вятърна инсталация. Природните високи ветрови зони създават вятър при непредсказуеми скорости, които са много трудни за улавяне по точно местоположение. Като такива не можем да гарантираме изпълнението на навеса в тези крайни ситуации
- TR** "DURAMAX" dökümü, yüksek rüzgar tesisatı kurallarına göre kurulduğunda kontrollü bir laboratuvar ortamında yüksek rüzgar yüklerini test etti ve geçti. Doğal yüksek rüzgarlı bölgeler, konuma göre hassas bir şekilde yakalanması çok zor olan, öngörülemeyen hızlarda rüzgar yaratır. Bu nedenle, bu olağanüstü durumlarda kulübenin performansını garanti edemeyiz.



- EN** "For dismantling the Shed, Customer has to follow instructions manual in reverse direction."
- FR** " Pour le démantèlement du hangar, client doit suivre le manuel d'instructions dans le sens inverse."
- DE** In Gebieten mit starken Schneefällen oder starkem Wind empfehlen wir das nachstehende Zubehör.
- ES** "Para el desmantelamiento de la nave, cliente tiene que seguir instrucciones en sentido contrario".
- PT** "Para desmontar o galpão, cliente tem de seguir o manual de instruções em sentido reverso".
- NL** "Voor de ontmanteling van de schuur, klant heeft te volgen instructiehandleiding in omgekeerde richting."
- CS** 'Pro demontáž přístřešku musí zákazník postupovat podle pokynů v opačném směru.'
- SK** 'Pri demontáži prístrešku musí zákazník postupovať podľa pokynov v opačnom smere.'
- SL** 'Za demontažo skladišča mora naročnik slediti priročniku v obratni smeri.'
- HR** 'Za demontažu zida, korisnik mora slijediti priručnike za upute u obrnutom smjeru.'
- HU** 'A fészter lebontásához az Ügyfélnek vissza kell követnie az utasításokat.'
- SV** 'För att demontera Shed måste kunden följa instruktionsboken i omvänd riktning.'
- IT** 'Per lo smontaggio del capannone, il cliente deve seguire manualmente le istruzioni in senso inverso'..
- PL** do demontażu szopy, należy postępować zgodnie z instrukcją obsługi w odwrotnym kierunku
- RO** 'Pentru dezmembrarea Shedului, Clientul trebuie să urmeze manualul de instrucțiuni în sens invers.'
- BG** 'За демонтиране на навеса клиентът трябва да следва инструкциите в наръчник в обратна посока.'
- TR** 'Shed'in sökülmesi için, Müşteri yönergeleri ters yönde takip etmelidir.'



- EN** ADDITIONAL ACCESSORIES AVAILABLE
(Not included)
- FR** ACCESSOIRES ADDITIONNELS DISPONIBLES
(non inclus)
- DE** WEITERES ZUBEHÖR
(Nicht enthalten)
- ES** ACCESORIOS ADICIONALES DISPONIBLES
(no incluida)
- PT** ACESSÓRIOS ADICIONAIS DISPONÍVEIS
(não incluído)
- NL** EXTRA ACCESSOIRES AANWEZIG.
(niet inbegrepen)
- CS** MOŽNÉ DALŠÍ DOPLŇKY.
(není součástí balení)
- SK** DOSTUPNÉ DODATOČNÉ PRÍSLUŠENSTVO
(nie je súčasťou balenia)
- SL** RAZPOLOŽLJIVA DODATNA OPREMA
(niso vključene)
- HR** DODATNI PROGRAMI RASPOLOŽIV
(nije uključeno)
- HU** TOVÁBBI MEGVÁSÁROLHATÓ TARTOZÉKOK
(nem tartozék)
- SV** YTTERLIGARE TILLGÄNGLIGA ACCESSOARERV
(ingår ej)
- IT** ACCESSORI SUPPLEMENTARI DISPONIBILI
(non incluso)
- PL** DOSTĘPNE DODATKOWE AKCESORIA
(nie wliczone)
- RO** ACCESORIILE SUPLIMENTARE DISPONIBILE
(Nu este inclus)
- BG** ДОПЪЛНИТЕЛНИ НАЛИЧНИ АКЕСОАРИ
(не е включен)
- TR** EK AKSESUARLAR MEVCUTTUR
(dahil değildir)



- EN** These accessories are required in case of heavy snow or high wind areas. Please choose relevant accessories according to your needs.
- FR** Ces accessoires sont exigés en cas de zones de la neige forte ou du vent fort. Veuillez choisir les accessoires appropriés selon vos besoins.
- DE** In Gebieten mit starken Schneefällen oder starkem Wind empfehlen wir das nachstehende Zubehör.
- ES** Estos accesorios son requeridas en caso de fuertes nevadas o zonas de alto viento. Por favor, elija los accesorios pertinentes de acuerdo a sus necesidades.
- PT** Estes acessórios são necessários em áreas de vento forte e/ou neve. Por favor, escolha os acessórios pertinentes de acordo com suas necessidades.
- NL** Deze accessoires zijn nodig in geval van hevige sneeuw val of gebieden waar het hard waait. Gebruik de accessoires die u nodig heeft.
- CS** Tyto doplňky se vyžadují v místech s velkým množstvím sněhu či silným větrem. Zvolte si prosím příslušné doplňky podle vašich potřeb.
- SK** Toto príslušenstvo sa vyžaduje v prípadoch ťažkého a veľkého množstva snehu alebo silného vetra. Vyberte si relevantné príslušenstvo na základe vašich potrieb.
- SL** Ta dodatna oprema se uporablja v primeru velike količine zapadlega snega ali če lopa stoji na zelo vetrovnem območju. Izberite ustrezno opremo glede na to, kaj dejansko potrebujete.
- HR** Ovi dodaci su potrebni u slučaju teškog snijega ili jak vjetar regija. Molimo odaberite relevantne dodatne opreme prema vašim potrebama.
- HU** Ezekre a tartozékokra sürű havazás esetén vagy erősen szeles területeken van szükség. Kérjük, igénye szerint válasszon a megfelelő tartozékok közül.
- SV** Dessa accessoarer behövs vid tung snö eller i områden med hård vind. Var god välj relevanta accessoarer efter behov.
- IT** Questi accessori sono importanti in caso di neve o aree soggette a forti venti. Per favore, scegli questi accessori in base ai tuoi bisogni.
- PL** Akcesoria te są wymagane w przypadku terenów, na których zdarzają się duże opady śniegu lub silnewiatry. Wybierz odpowiednie akcesoria w zależności od potrzeb.
- RO** Aceste accesorii sunt necesare în cazul în cazul în care apar depuneri masive de zăpadă sau în zonele în care bate vânt puternic. Vă rugăm alegeți accesorii potrivite nevoilor dumneavoastră.
- BG** Тези акесоари се изискват в случай на тежък сняг или при райони със силен вятър. Моля подберете съответните акесоари според нуждите.
- TR** Bu aksesuarlar yoğun kar yağışı ya da kuvvetli rüzgar alan bölgelerde gereklidir. Lütfen ihtiyaçlarınıza uygun gerekli aksesuarları seçiniz.

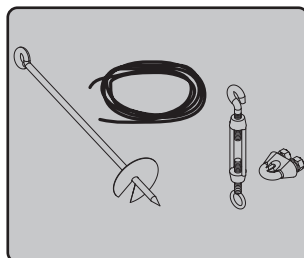

1

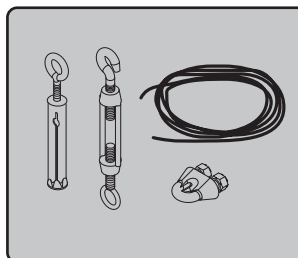

2

1

- | | |
|------------------------------------|--------------------------------|
| EN ANCHOR KIT (Soil) | HR SIDRO KOMPLET (tla) |
| FR KIT D'ANCRE (Sol) | HU RÖGZÍTŐ FELSZERELÉS (Talaj) |
| DE ANKER-KIT (Boden) | SV FÖRANKRINGS-KIT (Jord) |
| ES KIT DE ANCLAJE (Suelo) | IT KIT DI ANCORAGGIO (Suolo) |
| PT KIT DE APOIO (Solo) | PL ZESTAW DO MOCOWANIA (Grunt) |
| NL ANKER GEREEDSCHAP (bodem) | RO SET DE ANCORARE (ÎN SOL) |
| CS KOTEVNÍ SOUPRAVA (Hlína) | BG КОМПЛЕКТ АНКЕРИ (Почва) |
| SK UKOTVOVACIE PRÍSLUŠENSTVO (zem) | TR EKLEMLEME KİTİ (Toprak) |
| SL SIDRNA OPREMA (zemlja) | |

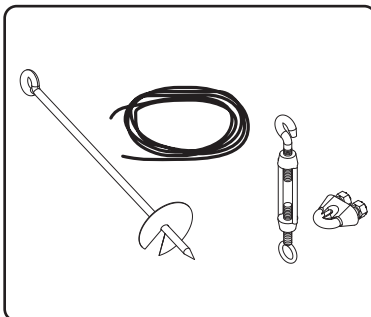

- EN** Wire rope with twist augers for sheds installed with foundation (Wood / Metal) on soil.
For heavy wind area.
- FR** Fil de fer avec des foreuses de torsion pour des hangars installés avec la base (en métal / en bois) sur le sol. **Pour la zone du vent fort.**
- DE** Seil mit Erdbohrer bei einem Unterbau (Holz / Metall) auf dem Boden.
Für Gebiete mit starkem Wind.
- ES** El cable metálico para casetas instaladas con kit de estructura de suelo fijada al terreno
- PT** Cabo metálico com brocas para galpões instalados com base (Madeira/Metal) em solo.
Para áreas de vento forte.
- NL** Bedrading met kronkelige grondboren voor het schuurtje moet met fundering worden geïnstalleerd (hout/metaal) op bodem. **Voor hevige wind gebieden.**
- CS** Drátěné lano se vrtáky pro kůlny postavené se základy (dřevo / kov) na hlíně.
Pro místa se silným větrem.
- SK** Drôtené lano s krútenými špirálovými šnekmi pre hangáre nainštalované zo základom (drevo/kov) na zemi. **Pre oblasť so silným vetrom.**
- SL** Žična vrv z velikim svedrom z enojno spiralo za lope nameščene na temelju (les/kovina) na zemlji.
Za zelo vetrovna območja.
- HR** čelikčelo s okretati svrdlom za baca instaliran s temelja (Drvo / Metal) na tlu.
Za teške vjeter području.
- HU** Drótkötél spirálfúrókkal alappal rendelkező kerti fészerekhez (Fa / fém) talajon.
Erősen szeles területekre.
- SV** Wirelås med tvistborr för skjul installerade med grund (trä / metall) på jord.
För områden med hård vind.
- IT** Fune con trivella a spirale per capannoni installati con fondamenta (legno/metallo) sul suolo.
Per aree soggette a forte vento.
- PL** Lina stalowa ze świdrami dla magazynków montowanych na pod stawie (Drewno/Metal) do gruntu.
Przeznaczone do użytkowania na obszarach występowania silnych wiatrów.
- RO** Cabluri cu burghie răsucite pentru magazine asamblate pe fundație (Lemn / Metal) în sol.
Pentru zonele în care bate vânt puternic.
- BG** Стоманено въже с извити сонди за заслони, монтирани върху фундаменти (Дърво / Метал) върху почва.
За силно ветровита зона.
- TR** Zemin (tahta/metal) toprak üstüne gelecek şekilde inşa edilen barınaklar için burgulu matkap ve tel ip.
Kuvvetli rüzgar alan yerler için.

2

- | | |
|--------------------------------------|--------------------------------|
| EN ANCHOR KIT (Concrete) | HR SIDRO KOMPLET (beton) |
| FR KIT D'ANCRE (Béton) | HU RÖGZÍTŐ FELSZERELÉS (Beton) |
| DE Verankerungsset (Beton) | SV FÖRANKRINGS-KIT (Betong) |
| ES KIT DE ANCLAJE (hormigón) | IT KIT DI ANCORAGGIO (cemento) |
| PT KIT DE APOIO (Concreto) | PL ZESTAW DO MOCOWANIA (Beton) |
| NL ANKER GEREEDSCHAP (Beton) | RO SET DE ACORARE (Beton) |
| CS KOTEVNÍ SOUPRAVA (Beton) | BG КОМПЛЕКТ АНКЕРИ (Бетон) |
| SK UKOTVOVACIE PRÍSLUŠENSTVO (betón) | TR EKLEMLEME KİTİ (Beton) |
| SL SIDRNA OPREMA (beton) | |

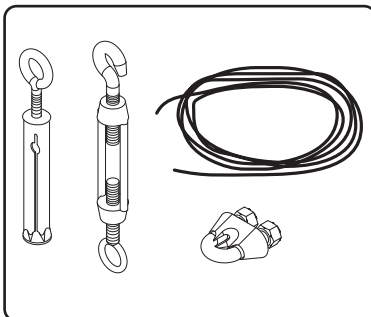

- EN** Eye bolt with wire rope for sheds installed with foundation (Wood / Metal) on concrete.
For heavy wind area.
- FR** OEil à queue filetée avec fil en fer pour des hangars installés avec la base (en métal / en bois) sur le béton.
Pour la zone du vent fort.
- DE** Ringschraube mit Seil für Gerätee Häuser mit einem Unterbau (Holz / Metal) auf Beton.
Für Gebiete mit starkem Wind.
- ES** Coloque pernos de ojo y el cable metálico para las zonas de fuerte viento.
Para el área del fuerte viento.
- PT** Cavilha com cabo de aço para galpões instalados com base (Madeira/Metal) em concreto.
Para áreas de vento forte.
- NL** Eyebolt met stalendraad voor schuurtje moet worden geïnstalleerd met fundering (hout/metaal) op beton.
Voor hevige wind gebieden.
- CS** Oka s drátěným lanem pro kůlny postavené se základy (dřevo / kov) na betonu.
Pro místa se silným větrem.
- SK** Šrob s okom s drôtovým lanom pre hangáre nainštalované so základom (drevo/kov) na betóne.
Pre oblasti so silným vetrom.
- SL** Očesni vijak z žično vrvjo za lope nameščene na temelju (les/kovina) na betonu.
Za zelo vetrovna območja.
- HR** oči vijak žičane užadi za baca Installer sa temelja (Drvo / Metal) na betonu.
Za teške vjetar području.
- HU** Gyűrűs csavar drótkötéllal alappal rendelkező kerti fészerekhez (Fa / fém) betonon.
Erősen szeles területekre.
- SV** Stagöglå med wirelås för skjul som installerats med grund (Trä / Metall) på betong..
För områden med hård vind.
- IT** Vite ad occhio con fune per capannoni installati con fondamenta (legno/metallo) sul cemento.
Per aree soggette a forte vento.
- PL** Śruba z uchem z liną stalową dla magazynków montowanych na podstawie (Drewno/Metal) do betonu.
Przeznaczone do użytkowania na obszarach występowania silnych wiatrów.
- RO** Șurub cu ochi atașat la un cablu pentru magaziile asamblate pe fundație (Lemn / Metal) în beton.
Pentru zonele în care bate vânt puternic.
- BG** Шарнирен болт със стоманено въже за заслони, инсталирани с фундамент (Дърво / Метал) върху бетон.
За силно ветровита зона.
- TR** Zemin (tahta/metal) beton üstüne gelecek şekilde inşa edilen barnaklar için halkalı vida ve tel ip.
Kuvvetli rüzgar alan yerler için.



U.S. Polymers, Inc.
1057 S. Vail Ave
Montebello, CA 90640,
United States of America

www.duramaxbp.com