



## Operating Instructions

**Fundamental safety instructions**

**1**

**Introduction**

**2**

**Installation and Technical specifications**

**3**

**Keypad operation**

**4**

**Monitoring and Fault**

**5**

**Parameter list**

**6**

**Communicating with the PCL**

**7**

**Maintenance and care**

**8**

## Legal information

### Warning notice system

Please read this manual carefully and follow all safety precaution before moving, installation, operation and servicing the inverter. It may cause physical injury or death, or damage the device if you ignored. Therefore, Our company will not be responsible for any damage and we are not legally bound in any manner.



#### DANGER

Indicates that death or server personal injury will result if proper precaution are not taken.



#### WARNING

Indicates that death or severe personal injury may result if proper precautions are not taken.



#### CAUTION

Indicates that minor personal injury can result if proper precautions are not taken.



#### NOTICE

Indicates that property damage can result if proper precautions are not taken.

otice warning of injury to persons with a safety alert symbol may also include a warning relating to property damage.

### Qualified Personnel

The product/system described in this documentation may be operated only by **personnel qualified** for the specific task accordance with relevant documentation, in particular its warning notices and safety instructions. Qualified personnel are those who, based on their training and experience, are capable of identifying risks and avoiding potential hazards when working with these products/system.

### Disclaimer of Liability

we have reviewed the contents of this publication to ensure consistency with the hardware and software described. Since variance cannot be precluded entirely, we cannot guarantee full consistency. However, the information in this publication is reviewed regularly and any necessary corrections are included in subsequent editions.

### Certificate Approval

The following list of the certificates and standards that the products may comply with. For detail about acquired certificates, see the certification marks on the products nameplate.

Certification	Directives		Standards
CE	EMC	2017/02/EU	EN 61800-3:2017
	LVD	2015/07/EU	EN 61800-2:2015
		2017/10/EU	EN61800-5-1:2007/A1:2017
UL	-	-	UL508C/UL61880-5-1

## Table of contents

<b>1. Fundamental Safety Instructions.....</b>	<b>1</b>
<b>2. Introduction</b>	
2.1	
2.2	
<b>3. Installation</b>	
3.1. Mechanical installation	
3.2. Electrical installation	
3.3.	
<b>4. Keypad operation</b>	
4.1. Keypad Instruction	
4.2. Electrical installation	
4.3. Keypad instruction	
<b>5. Monitoring code and fault</b>	
5.1 Monitoring code	
5.2 Fault and alarm	
<b>6. Parameter List</b>	
<b>7. Communication of PLC</b>	
<b>8. Maintenance and care</b>	
.	

# Fundamental safety instruction

## Purpose of this manual

This manual provides you with information about the proper installation, commissioning, operation, and maintenance of inverter.

## 1.1 General safety instructions

### DANGER

Electric shock and danger to life due to other energy sources.

Touching live components can result in death or severe injury.

- Only work on electrical devices when you are **qualified** for this job.
- Always observe the country-specific safety rules.

Generally, the following six steps apply when establishing safety:

1. Prepare for disconnection. Notify all those who will be affected by the procedure.
2. Isolate the drive system from the power supply and take measures to prevent it being switched back on again.
3. Wait until the discharge time specified on the warning labels has elapsed.
4. Check that there is no voltage between any power connection, and between any of the power connections and the protective conductor connection.
5. Check whether the existing auxiliary supply circuits are de-energized.
6. Ensure that the motors cannot move.
7. Identify all other dangerous energy sources, e.g. compressed air, hydraulic systems, or water. Switch the energy sources to safe state.
8. Check that the correct drive system is completely locked.

After you have completed the work, restore the operational readiness in the inverse sequence.

### WARNING

- Check the input voltage meet inverter's requirement.
- Ensure the protective earthing conductor complies with technical standard and local safety regulations.
- Connect input voltage of 220V/380V is strictly prohibit to signal terminals expect TA/TB.
- No AC power input to the terminal U, V and W, it will cause serious damage and fire to the inverter.

### CAUTION

- Tighten all power connections to the prescribed torque.
- Check that there are no screws, cables and other conductive items left in the driver.
- Check that the accessories of the inverter are correctly and properly installed. cables should meet the needs of every component (including input reactors, input filters, output reactors, output filters, DC reactors, braking units and braking resistors).

## 2.1 Rated output power of inverter

The inverters designed for controlling the speed of three phase asynchronous motors.

Table of model selection

Input voltage (V)	Model	Rated Capacity	Rated Output current	Rated out power
Single phase 220V	VS0.75G	1.4KVA	4.0A	0.75kW
	VS1.5G	2.6KVA	7.0A	1.5kW
	VS2.2G	3.8KVA	10.0A	2.2kW
	VS4.0G	8.8KVA	16.0A	4.0kW
	VS5.5G	11.0KVA	22.0A	5.5kW

## 2.2 Technical specifications

Item		Description
Input	voltage (V)	AC 1PH 220V(-20%)~240V(+20%)
	frequency (Hz)	50Hz or 60Hz (±5%)
Output	Voltage (V)	0~220V
	Frequency (Hz)	0~999Hz
	Overload capacity	150% of over current: 1 minute 180% of over current: 10 seconds
Control feature	Control mode	SVPWM, SVC, V/F, Advanced V/F, Separated V/F, V/F curve.
	Motor type	Asynchronous motor
	Speed ratio	1:100 (SVC)
	Starting torque	3.0Hz/150%(Advanced V/F mode)
	Speed control accuracy	≤±0.2% (SCV)
	Speed fluctuation	≤±0.5% (SCV)
	Torque response	≤50ms (SCV)
	Torque control accuracy	Torque accuracy control: 5% (SCV)
	Torque boost	Auto boost ; manual boost:0.1%~30.0%
	V/F curving	Liner VF, quadratic VF, multi-point VF
Others	DC braking, AVR, auto current limit, auto voltage limit, carrier	

		frequency adjustment, etc.
Customized feature	V/F separate control	Easy connection for different power supply.
	Multi source reference	Frequency of multi source control customize.
	Jog setting	FWD/REV frequency, Jumping frequency, ACC/DEC frequency
	Pipe bust detection	Pipe bust detection time delay, threshold detection.
Peripheral interface	Control source	Keypad, terminals, RS485.
	Frequency control source	2 different digital controls, analog terminals, switch terminals, pulse terminal, multi-step speed control.
	Pulse control channel	High speed pulse control: 0~50KHz
	Analog control channel	2 channels: 0~20mA or 0~10V
	Relay control channel	1 channels programmable relay output Contactor capacity: 3A/250VAC, 3A/30VDC
Others	Mountable method	Wall, flange and floor mountable
	Operation Temperatures	-10℃~+50℃ (40~50℃ with derating)
	Storage Temperature	
	Protection class	IP20
	Cooling	Air-cooling
	Braking unit	External braking unit needed.
	EMC filter	380V series products can meet the requirements of IEC61800-3 C3 External optional filter: meet the requirement of IEC61800-3 C
	Power efficiency	≥93% of output power

## Installation

### 3.1 Mechanical installation

#### 3.1.1 Mounting clearance

<b>Top</b>	<b>≥ 100mm</b>
<b>Bottom</b>	<b>≥ 100mm</b>
<b>Side</b>	<b>≥ 15mm</b>

#### 3.1.2 Installation Environment

	<b>NOTICE</b>
<ul style="list-style-type: none"> <li>● The inverter must be up-right mounting in a well-ventilated indoor site for best cooling result.</li> <li>● Check that the ambient temperature for the inverter is between -10~45°C. If the ambient over 40°C, derate 1% for every extra 1°C. operation over 45°C may reduce reliability of the device.</li> <li>● Site humidity ≤90% RH with no condensation.</li> <li>● Mounting location vibration less than 0.5G in case of dropping. No sudden impact.</li> <li>● Away from the location with strong magnet field and protected against corrosive, combustible or explosive gases and vapor.</li> <li>● Ensure that mounting on fire protection material (eg. Metal).</li> <li>● The device normal operation must be less than 1000 meter, if over this attitude, please derate 1% for every additional 100m.</li> </ul>	

#### 3.1.4 Recommend Switch and Cable

For different rated power of inverter, the table shows recommended of Air Switch(MCCB), Volume of Contactor and Insulated Copper Cable cross-section.

Rated output Power (kW)	Input Protection		Cable Cross-section		Signal cable (mm <sup>2</sup> )
	Air switch (A)	Contactor (A)	Power supply cable (mm <sup>2</sup> )	Motor cable (mm <sup>2</sup> )	
VS0.75G	16	10	1.5	1.5	≥0.5
VS1.5G	20	16	2.5	1.5	≥0.5
VS2.2G	32	20	4.0	2.5	≥0.5
VT0.75G	10	10	1.0	1.0	≥0.5
VT1.5G	16	10	1.0	1.0	≥0.5
VT2.2G	16	10	1.5	1.5	≥0.5

VT3.7G/5.5P	25	16	2.5	2.5	≥0.5
VT5.5G/7.7P	32	25	4.0	4.0	≥0.5
VT7.5G/11P	40	32	4.0	4.0	≥0.5
VT11G/15P	63	40	6.0	6.0	≥0.5
VT15G/18.5P	63	40	6.0	6.0	≥0.5
VT18.5G/22P	100	63	10	10	≥0.5
VT22G/30P	100	63	16	16	≥0.5
VT30G/37P	125	100	25	25	≥0.5
VT37G/45P	160	100	25	25	≥0.5
VT45G/55P	200	125	35	35	≥0.5
VT55G/75P	200	125	50	50	≥0.5
VT75G/90P	250	160	70	70	≥0.5

## 3.2 Electrical installation

1.Basic Wiring

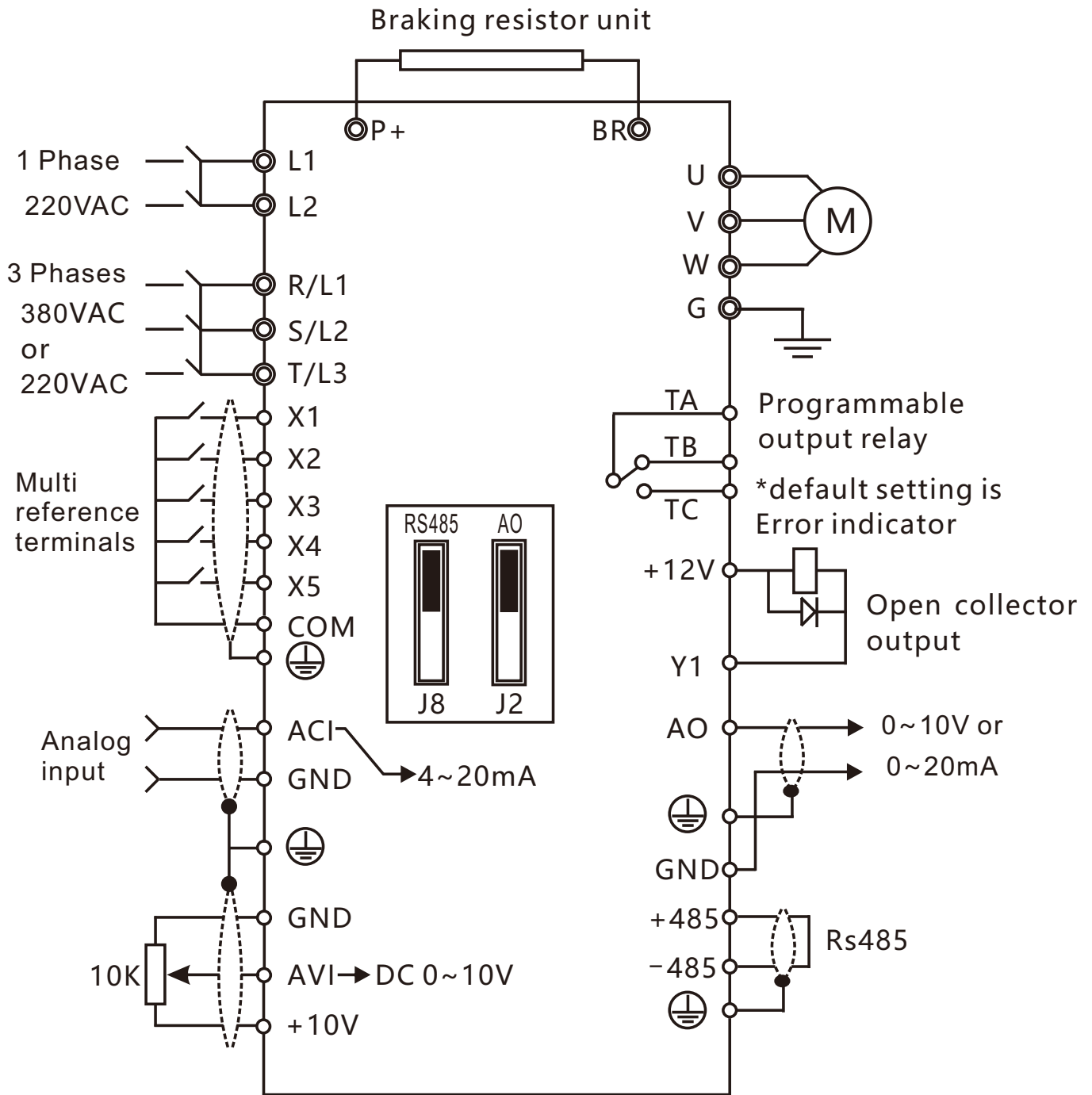

2. terminals of control circuit

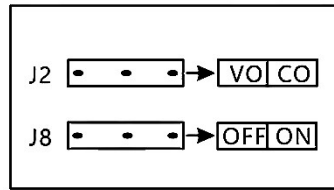







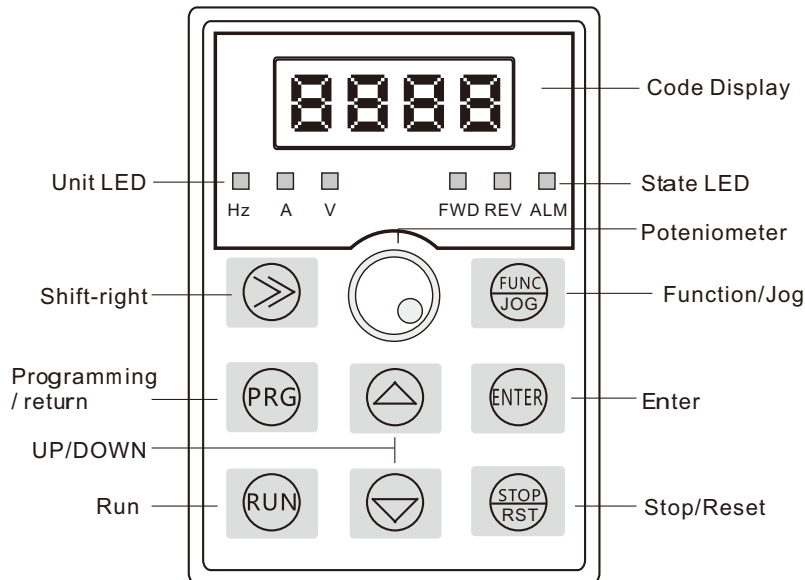

J2	
Vo	AO output is voltage signal
Co	AO output is current signal
J8	
OFF	No resistor meets Rs485 is connected
ON	Resistor meets Rs485 is connected

## Keypad operation

### 4.1 Keypad introduction



Signal LED Description		
Sign	Name	Description
State LED	FWD	Forward Running
	REV	Reverse Running
	ALM	Faulty sign
Unit LED	V	Voltage Unit
	A	Current Unit
	Hz	Frequency Unit
Code Display	4-figure LED display shows various monitoring data and alarm.	
Potentiometer	Tuning frequency. Please refer to P0.03	
	Right-shift key	Shift to next digit place.
	Programming key	Enter or back to level menu and delete shortcut parameter.
	Run key	Start in operation mode
	UP key	Increase function code or data
	DOWN key	Decrease function code or data
	Function key	Function refer to
	Enter key	Confirm or enter to next level menu

	Stop key	Stop operation or reset error state.
---	----------	--------------------------------------

## 4.2 Keypad instruction

This keypad has 4 -grade parameter menu, which is Group Code ( 1<sup>st</sup> grade), Function Code (2<sup>nd</sup> grade), Function value (3<sup>rd</sup> grade) and Monitoring value (4<sup>th</sup> grade).

1. Check operation status or faulty code: During the device operation or stopping, press  twice, shows “d” on the display, follow the parameter table of d-group to check the value.
2. For example: Change the setting value of FA.02 from 50.00 to 60.00, then check the monitoring value of d-15 which is PID feedback value. The steps shows below:

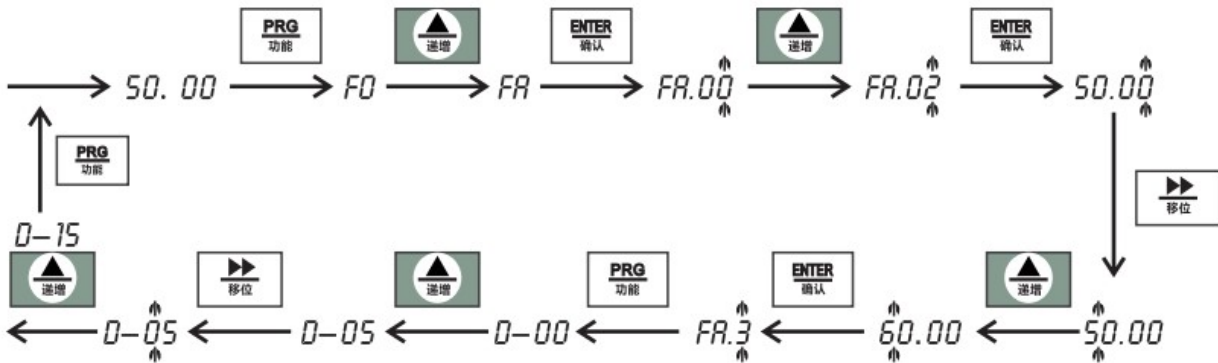

# Monitoring Codes and fault

## 5.1 Monitoring

Group d - Status Monitoring					
Code	Name	Value range	Unit	Default	Modify
d-00	Output frequency	0.0~999.9Hz	0.1Hz	0.0Hz	◆
d-01	Setting frequency	0.0~999.9Hz	0.1Hz	0.0Hz	◆
d-02	Output voltage	0~999V	1V	0V	◆
d-03	Bus voltage	0~999V	1V	0V	◆
d-04	Output current	0.0~999.9A	0.1A	0.0A	◆
d-05	Motor speed (Krpm)	0~60000Krpm	1Krpm	Rated	◆
d-06	AVI input voltage (V)	0.00~10.00V	0.01V	0.00V	◆
d-07	ACI input current (mA)	0.00~20.00mA	0.01mA	0.00mA	◆
d-08	AO output (V/mA)	0.00~10.00V/0.00~20.00mA	0.01V/mA	0.00V/mA	◆
d-09	Reserved	-	-	0	◆
d-10	Pulse(X5) input frequency	0.00~99.99KHz	0.01KHz	0.00KHz	◆
d-11	PID feedback value	0.00~10.00V/0.00~99.99(MPa、Kg)	0.01V/(MPa, Kg)	0.00V/(MPa、Kg)	◆
d-12	Current counter value	0~9999s	1s	0s	◆
d-13	Current timer value	0~9999s	1s	0s	◆
d-14	Terminal status (X1~X5)	0~1FH	1H	0H	◆
d-15	Relay output status (Y1/TA/TB/TC)	0~3H	1H	0H	◆
d-16	IGBT temperature	0.0~132.3℃	0.1℃	0.0	◆
d-17	CPU updated year	2010~2026	1	2019	◆
d-18	CPU updated date (month and date)	0~1231	1	0426	◆
d-19	the error at the last but one	0~19	1	0	◆
d-20	The last error	0~19	1	0	◆
d-21	The frequency of last error	0.0~999.9Hz	0.1Hz	0.0Hz	◆
d-22	The current of last error	0.0~999.9A	0.1A	0.0V	◆
d-23	The bus voltage of last error	0~999V	1V	0V	◆
d-24	The IGBT temperature of last error	0.0~132.3℃	0.1℃	0.0℃	◆
d-25	Total running time of the inverter(Hour)	0~9999h	1h	0h	◆

d-26	Status of the inverter	0~FFFFH BIT0: Run/Stop BIT1: Forward/Reverse BIT3: Jogging BIT3: Start with DC braking BIT4: Reserved BIT5: Overvoltage protection BIT6: frequency constant ramp-down BIT7: overcurrent protection BIT8~9: 00-Zero speed/01-Acceleration /10-Deceleration/11-constant speed BIT10: Overload warning BIT11: Reserved BIT12~13 control channel: 00-keypad potentiometer /01-Terminals /10-Reserved BIT14~15 Bus voltage status: 00-Normal/01-undervoltage protection /02-Overvoltage protection	1H	0H	◆
------	------------------------	--	----	----	---

## 5.2 Fault and alarm

Group E - Fault code			
Code	Name	Cause	Remedy/Solution
E0C1	<b>Overcurrent during accelerating</b>	<ul style="list-style-type: none"> <li>Motor power does not correspond to the inverter power</li> <li>Motor lead shorted circuit.</li> <li>Earth fault</li> <li>Shock load exceeds specified limit.</li> </ul>	Checking the following: <ul style="list-style-type: none"> <li>Motor power must be correspond to the inverter power</li> <li>Cable length limit must not be exceeded.</li> <li>Motor cable and motor must have no short-circuits or earth faults.</li> <li>E0C1: Increase ramp-up time.</li> <li>E0C2: Increase ramp-down time.</li> <li>Reduce torque boost level.</li> </ul>
E0C2	<b>Overcurrent during decelerating</b>		
E0C3	<b>Overcurrent during constant running</b>		
EHU1	<b>Overvoltage during accelerating</b>	<ul style="list-style-type: none"> <li>Main supply voltage too high</li> <li>Motor is not fully stopped.</li> <li>Relay is not working properly</li> </ul>	Checking the following: <ul style="list-style-type: none"> <li>Supply voltage must lie within the limits indicates on rating plate.</li> <li>Ramp-down time must match inertial of load.</li> <li>Required DC braking resistor must lie within specified limits.</li> </ul>
EHU2	<b>Overvoltage during decelerating</b>		
EHU3	<b>Overvoltage during constant running</b>		
EHU4	<b>Overvoltage during stopping</b>		
ELU0	<b>Undervoltage during operating</b>	<ul style="list-style-type: none"> <li>Main supply failed</li> </ul>	Cheek supply voltage
ESC1	<b>IGBT module fault</b>	<ul style="list-style-type: none"> <li>The inverter is transient overcurrent.</li> <li>Earth fault</li> <li>IGBT over temperature.</li> <li>Main control board fault or interference.</li> <li>Device hardware fault</li> </ul>	<ul style="list-style-type: none"> <li>Check on E0C1~E0C3 remedy.</li> <li>Check that load steps and shock loads lie within specified limits</li> <li>Call retailer or factory service.</li> </ul>
E-0H	<b>Inverter over temperature</b>	<ul style="list-style-type: none"> <li>Warning level of inverter heat sink temperature</li> <li>warning level of chip junction temperature.</li> </ul>	<ul style="list-style-type: none"> <li>Heat sink is clear</li> <li>Fan must turn when inverter in operation.</li> </ul>

			<ul style="list-style-type: none"> <li>● Ambient temperature must lie within specified limits</li> </ul>
EOL1	<b>Inverter overloaded</b>	<ul style="list-style-type: none"> <li>● V/F curve or torque boost setting is inappropriate</li> <li>● Input voltage is too low.</li> <li>● Motor overloaded</li> </ul>	<ul style="list-style-type: none"> <li>● Change the V/F curving or torque boost setting</li> <li>● Increase ramp-up time.</li> <li>● Load or load cycle too high?</li> </ul>
EOL2	<b>Motor overloaded</b>	<ul style="list-style-type: none"> <li>● Motor over temperature.</li> <li>● Input voltage too low.</li> </ul>	<ul style="list-style-type: none"> <li>● Check P5.01 reference is setting properly.</li> <li>● Check the load or load cycle too high.</li> <li>● Motor current is not in excess of the motor nominal current as indicated by the motor rating plate</li> </ul>
E-EF	<b>External device fault</b>	<ul style="list-style-type: none"> <li>● External device failure input terminals action</li> </ul>	<ul style="list-style-type: none"> <li>● Disable terminal input for fault trigger</li> <li>● Check error state is clean.</li> </ul>
EPID	<b>PID feedback fault</b>	<ul style="list-style-type: none"> <li>● Wire loose or broken</li> <li>● Signal out of limit</li> </ul>	<ul style="list-style-type: none"> <li>● Check wiring is correct.</li> <li>● Check detection limit setting.</li> </ul>
E485	<b>RS485 fault</b>	<ul style="list-style-type: none"> <li>● The inverter not match the baud rate of upper limit.</li> <li>● RS485 is interfered.</li> <li>● Communication out of time</li> </ul>	<ul style="list-style-type: none"> <li>● Check baud rate limit setting.</li> <li>● Use twisted-pair or shielded cable.</li> <li>● Retry communication.</li> </ul>
ECCF	<b>Current detection fault</b>	<ul style="list-style-type: none"> <li>● Current detection circuit fault</li> <li>● Auxiliary power supply failure</li> </ul>	<ul style="list-style-type: none"> <li>● Call the service</li> </ul>
EEEEP	<b>EEPROM fault</b>	<ul style="list-style-type: none"> <li>● Read or write failure while access to EEPROM</li> <li>● This can also caused by the EEPROM being full, too much parameter has been changed.</li> </ul>	<ul style="list-style-type: none"> <li>● Must be power-cycled to cancel this bug as some parameters may not be read correct</li> <li>● Factory reset and new parameterization, if power-cycle does not remove fault</li> <li>● Change some parameters back to default values if the EEPROM is full, then power-cycle</li> <li>● Call factory service for help.</li> </ul>
EPAO	<b>Pipe bust detected</b>	<ul style="list-style-type: none"> <li>● Pressure feedback is smaller than the lower limit, or reach the upper limit.</li> <li>● Cable loose.</li> </ul>	<ul style="list-style-type: none"> <li>● Check the setting of limit match the needs.</li> <li>● Pipe bust occur..</li> </ul>
EPOF	<b>CPU fault</b>	<ul style="list-style-type: none"> <li>● CPU communication fault</li> </ul>	<ul style="list-style-type: none"> <li>● Call service for help.</li> </ul>

# Parameter list

Parameter List					
○—changable all the time		×—Changable when stop		◆—Fixed	
				◇—Factory value	
F0 - BASIC REFERENCE					
code	Parameter	Parameter Instruction	Setting Range	Default	Prope rty
F0.00	Inverter power	Rated power value of the inverter	0.10~99.99kW	Default	◆
F0.01	MCU version	The current main control unit software version	1.00~99.99	1.00	◆
F0.02	Command source selection	0: Keypad control 1: Terminal I/O control 2: Serial comms. RS485	0~2	0	○
F0.03	Main Frequency setting channel selection	0: Panel Potentiometer input 1: Panel setting (▲/▼) 2: RS485. setting (UP/DOWN) 3: AVI Analog reference (0~10V voltage input) 4: Multi-channel reference 5: ACI Analog reference (0~20mA input) 6: RS485 reference 7: Pulse reference NOTE: the detail for multi reference, please check the parameter [F1.15].	0~7	0	○
F0.04	Max. output frequency	This parameter is used to set the Maximum out frequency of the inverter. Users should pay attention to this parameter because it is the foundation of frequency setting and speed of the acceleration and deceleration.	MAX {50.0, 【F0.05】} ~ 999.9Hz	50.0Hz	×
F0.05	Upper limit of the running frequency	Upper limit running frequency which means the running out frequency of the device is lower than or equal to the maximum frequency.	MAX {0.1, 【F0.06】} ~ 【F0.04】	50.0Hz	×
F0.06	Lower limit of the running frequency	Lower limit frequency which means the running frequency cannot be less than the lower limit. NOTE: Max. frequency $\geq$ upper limit frequency $\geq$ lower limit frequency .	0.0~upper limit refq.	0.0Hz	×
F0.07	action when reaching the lower limit	0:running at zero speed 1:running at lower limit reference 2:stop	0~2	0	×
F0.08	digit frequency setting	This setting is the starting value of the digit frequency reference.	0.0~upper limit refq.	10.0Hz	○

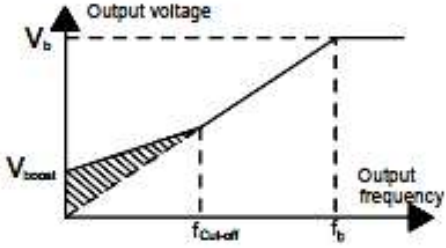
F0.09	Digit frequency reference	<p>LED unit: Power loss restore</p> <p>0: restore</p> <p>1: No restore</p> <p>LED tens: Refq. retentive after operation stop</p> <p>0: Retentive</p> <p>1: Not retentive</p> <p>LED hundreds digit: UP/DOWN function</p> <p>0: Invalid</p> <p>1: Valid</p> <p>LED thousand digit: PID, PLC frequency multi-channel reference</p> <p>0: Invalid.</p> <p>1: P0.03+PID</p> <p>2: P0.03+PLC</p>	0000~2111	0000	○						
F0.10	Accelerating time	Time spend of accelerate or decelerate from 0 to Max. Freq.									
F0.11	Decelerating time	<table border="1"> <thead> <tr> <th>Rated Power</th> <th>Default</th> </tr> </thead> <tbody> <tr> <td>0.4~4.0kW</td> <td>7.5s</td> </tr> <tr> <td>5.5~7.5KW</td> <td>15.0s</td> </tr> </tbody> </table>	Rated Power	Default	0.4~4.0kW	7.5s	5.5~7.5KW	15.0s	0.1~999.9s	Default	○
Rated Power	Default										
0.4~4.0kW	7.5s										
5.5~7.5KW	15.0s										
F0.12	Running direction	<p>0: Forward(FWD)</p> <p>1: Reverse(REV)</p> <p>2: Forbid to run in reverse</p>	0~2	0	○						
F0.13	V/F curve setting	<p>0: Linear V/F</p> <p>1: Square V/F</p> <p>2: Multi-point V/F</p>	0~2	0	×						
F0.14	Torque boost control	Torque boost is used for the compensation of low frequency torque, this setting is relative to the percentage of Max. output voltage ( $V_b$ ). Vector control selection on parameter F0.14=0.0.	0.0~30.0%		○						
F0.15	Cut-off frequency of torque boost	 <p>Below this frequency point (<math>f_{cut-off}</math>), the torque boost is effective, but over this frequency point, the torque boost is invalid.</p>	0.0~50.0Hz	15.0Hz	×						
F0.16	Carrier frequency setting	<p>The advantage of high carrier frequency: ideal current waveform, little current harmonic wave and motor noise. (See the figure above.)</p> <p>The disadvantage of high carrier frequency: Increasing the switch loss, increasing inverter</p>	2.0~16.0KHz	Rated	×						

		<p>temperature and the impact to the output capacity. The inverter power needs to be derated on high carrier frequency, every 10% derated for each additional 1k carrier power. At the same time, the leakage and electrical magnetic interference will increase.</p> <p>Applying low carrier frequency is contrary to the above, too low carrier frequency will cause unstable running, torque decreasing and surge. The manufacture has set a reasonable carrier frequency when the inverter is in factory. In general, users do not need to change the parameter.</p>			
F0.17	V/F frequency value F1	<p>When F0.13=3, the user can set V/F cure through F0.17~F0.21.</p> <p>V/F is generally set according to the load of the motor.</p> <p>NOTE: V1&lt;V2&lt;V3, F1&lt;F2&lt;F3. Too high low frequency voltage will heat the motor excessively or damage. The inverter may occur the overcurrent speed or overcurrent protection.</p>	0.1~Freq. F2	12.5Hz	×
F0.18	V/F voltage value V1		0.0~Volt. V2	25.0%	×
F0.19	V/F freq. F2		Freq. F1~F3	25.0Hz	×
F0.20	V/F Volt. V2		Volt. V1~V3	50.0%	×
F0.21	V/F Freq. F3		Freq. F2~rated Motor freq. [F4.03]	37.5Hz	×
F0.22	V/F voltage value V3		Volt V2~100.0% *(the rated motor voltage [F4.00])	75.0%	×
P0.23	User's password	The password protection will be valid after 3mins waiting or power-off when set any non-zero number.	0~9999	0	○

#### F1-AUXILARY REFERENCE

Code	Parameter	Parameter Instruction	Setting Range	Default	Property
F1.00	Start mode	<p>LED unit digits: start model</p> <p>0:Start from the direct starting freq. [F1.01]</p> <p>1: Start-up after DC braking: Start the motor from starting frequency after DC braking (F1.02 and F1.03).It is applicable in cases where revers rotation may occur to the most small-inertia loads during starting.</p> <p>LED tens digit: starting mode after unexpected power down or abnormal status.</p> <p>0:Invalid</p> <p>1: start from starting frequency[F1.01]</p>	0000~0011	00	×

		LED hundreds digit: Reserved LED thousands digit: Reserved			
F1.01	Direct starting frequency	Starting frequency of direct start-up means the original frequency during the inverter starting. The DC braking current and time before starting:	0.0~50.0Hz	1.0Hz	○
F1.02	The DC braking current before starting	The inverter will carry out DC braking at the braking current set before starting and it will speed up after the DC braking time. The stronger the braking current, the bigger the braking power. The DC braking current before starting means the percentage of the rated current of the invert	0.0~50.0% × rated freq.	0.0%	○
F1.03	The DC braking time before starting		0.0~30.0s	0.0s	○
F1.04	Stop mode	0: Decelerating to stop: the inverter decelerates to reduce the output frequency during the set time. When the frequency decreases to 0Hz, the inverter stops. IF DC braking function is active [P1.05~ P1.08], the inverter will stop after the process is finished. 1: Coast to stop: The inverter ceases the output immediately. And the load coasts to stop at the mechanical inertia.	0~1	0	×
F1.05	Starting frequency of DC braking	Starting frequency of DC braking: Start the DC braking when running frequency reaches starting frequency determined by P1.05.	0.0~upper limit freq.	0.0Hz	○
F1.06	DC braking current	DC braking time: the retention time of DC brake. If the time is 0, the DC brake is invalid. The inverter will stop at the set deceleration time.	0.0~50.0% × Motor rated current	0.0%	○
F1.07	DC braking time	DC braking current: The value of P1.06 is the percentage of rated current of inverter. The bigger the DC braking current is, the greater the braking torque is.	0.0~30.0s	0.0s	×
P1.08	Waiting time before DC braking	Waiting time before DC braking: Inverters block the output before starting the DC braking. After this waiting time, the DC braking will be started so as to prevent over-current fault caused by DC braking at high speed.	0.00~99.99s	0.00s	×
F1.09	Forward jogging freq.	Forward/Reverse jogging freq. setting	0.0~50.0Hz	10.0Hz	○
F1.10	Reverse jogging freq.				
F1.11	Jogging accelerate time	Accelerating time spend when the inverter runs from 0Hz to the Max. freq. The jogging decelerate	0.1~999.9S	Default	○

Fl. 12	Jogging decelerate time	time is contrary to the above.										
		Rated Power	Default									
		0.4~4.0kW	10.0s									
		5.5~7.5KW	15.0s									
Fl. 13	Jumping Freq.	When the set frequency is in the range of jumping frequency, the inverter can avoid the mechanical resonance point.	0.0 ~ upper limit freq.	0.0Hz	○							
Fl. 14	Jumping range		0.0~10.0Hz	0.0Hz	○							
Fl. 15	Frequency multi-reference source	0:keypad potentiometer + digital reference 1 1:keypad potentiometer + digital reference 2 2:keypad potentiometer + AVI 3:digital reference 1 + AVI 4:digital reference 2 + AVI 5:digital reference 1 + Multi-step speed 6:digital reference 2 + Multi-step speed 7:keypad potentiometer + Multi-step speed	0~7	0	×							
Fl. 16	Simple PLC	<b>LED unit:</b> PLC control 0: Disable 1: Enable <b>LED tens:</b> PLC running mode 0: Single cycle. The inverter stop after running once. 1: Cycle running. The inverter will keep on running until receiving a stop command. 2: Running as final reference status after single cycle. The inverter will keep running until receiving a stop command. <b>LED hundreds:</b> Start-up mode 0: Restart from the first step. 1: continue to run from the stop frequency caused by command or fault. 2: continue to run from the stop frequency and keep remaining running at the setting frequency caused by command or fault.. <b>LED thousands:</b> PLC memory restore after power loss 0: None retentive 1: Retentive	0000~1221	0000	×							
Fl. 17	Multi-step 1 (f <sub>1</sub> )	On PLC running selection, set Fl.17~Fl.35 to define the running frequency, time and direction of all steps. Multi-step frequency are in the range of - Max. frequency (-f <sub>max</sub> ) ~ Max. frequency (f <sub>max</sub> ), it can be set continuously.  <b>NOTE: the symbol of multi-step determines the running direction of simple PLC. The negative value means reverse rotation.</b>	-upper limit freq. ~ upper limit freq.	5.0Hz	○							
Fl. 18	Multi-step 2 (f <sub>2</sub> )			10.0Hz	○							
Fl. 19	Multi-step 3 (f <sub>3</sub> )			15.0Hz	○							
Fl. 20	Multi-step 4 (f <sub>4</sub> )			20.0Hz	○							
Fl. 21	Multi-step 5 (f <sub>5</sub> )			25.0Hz	○							
Fl. 22	Multi-step 6 (f <sub>6</sub> )			37.5Hz	○							
Fl. 23	Multi-step 7 (f <sub>7</sub> )			50.0Hz	○							
Fl. 24	Step1 running time	This inverter can set 7 steps speed, selected by the combination of multi-step terminals S1~S3[F2.13~F2.17], corresponding to the speed 0 to speed 7.	0.0~999.9s	10.0s	○							
Fl. 25	Step2 running time			10.0s	○							
Fl. 26	Step3 running time			10.0s	○							
		<table border="1"> <thead> <tr> <th>Step</th> <th>S1</th> <th>S2</th> <th>S3</th> </tr> </thead> <tbody> <tr> <td>1</td> <td>1</td> <td>0</td> <td>0</td> </tr> </tbody> </table>	Step	S1	S2	S3	1	1	0	0		
Step	S1	S2	S3									
1	1	0	0									

F1.27	Step4 running time	2	0	1	0		10.0s	○
F1.28	Step5 running time	3	1	1	0		10.0s	○
F1.29	Step6 running time	4	0	0	1		10.0s	○
F1.30	Step7 running time	5	1	0	1		10.0s	○
		6	0	1	1			
		7	1	1	1			
F1.31	Multi-step ACC/DEC time option 1	LED units digit: Step 1 ACC/DEC time 0~1 LED tens digit: Step 2 ACC/DEC time 0~1 LED hundreds digit: Step 3 ACC/DEC time 0~1 LED thousands digit: Step 4 ACC/DEC time 0~1				0000~1111	0000	○
F1.32	Multi-step ACC/DEC time option 2	LED units digit: Step 5 ACC/DEC time 0~1 LED tens digit: Step 6 ACC/DEC time 0~1 LED hundreds digit: Step 3 ACC/DEC time 0~1 LED thousands digit: Reserved				000~111	000	○
F1.33	ACC Time 2	Acceleration/Deceleration time setting				0.1~999.9s	10.0s	○
		Rated Power	Default					
F1.34	DEC Time 2	0.4~4.0kW	10.0s					
		5.5~7.5KW	15.0s					
F1.35	Multi-step time unit	LED unit digit: PID time unit LED tens digit: simple PLC time unit LED hundreds: General ACC/DEC time unit. LED thousands: Reserved 0: Seconds, the running time of all steps is counted by second. 1: Minutes, the running time of all steps is counted by minute. 2: 1/10 seconds, the running time of all steps is counted by 1/10s.				000~211	000	×

## F2- ANALOG AND DIGITAL INPUT/OUTPUT REFERENCE

Code	Parameter	Parameter Instruction	Setting Range	Default	Property
F2.00	Input volt. lower limit of AVI	Setting of upper and lower limit of the AVI input voltage.	0.00~【F2.01】	0.00V	○
F2.01	Input volt. upper limit of AVI		【F2.01】~10.00V	10.00V	○
F2.02	Corresponding setting of the lower limit of AVI	corresponding setting of upper and lower limit of AVI, this setting correspond to the percentage of frequency Max. reference[P0.05]	-100.0%~100.0%	0.0%	○
F2.03	Corresponding setting of the upper limit of AVI			100.0%	○
F2.04	Input current lower limit of ACI	Setting of upper and lower limit of the ACI input current	0.00~【F2.05】	0.00mA	○
F2.05	Input current upper limit of ACI		【F2.04】~20.00mA	20.00mA	○
F2.06	Corresponding setting of the	Corresponding setting of the upper and lower limit of ACI, this setting correspond to the	-100.0%~100.0%	0.0%	○

	lower limit of ACI	percentage of frequency Max. reference[F0.05]			
F2.07	Corresponding setting of the upper limit of ACI		100.0%	○	
F2.08	Analog input filter time	This parameter is used to adjust the sensitivity of the analog inputs: AVI, ACI and keypad potentiometer. Increasing the value properly can enhance the anti-interference of the analog, but weaken the sensitivity of the analog input.	0.1~5.0s	0.1s	○
F2.09	Analog input anti-fluctuation deviation limit	When the analog input signal fluctuate frequently around the reference value, this function properly to adjust the accuracy and stability of the system	0.00~0.10V	0.00V	○
F2.10	Terminal A0 output function	0:Output frequency 1:Output current 2: Motor running speed. 3: Output voltage 4: Analog AVI input value 5: Analog ACI input value	0~5	0	○
F2.11	Upper limit value of A0	Setting of A0 output lower and upper limit	0.00~10.00V/ 0.00~20.00mA	0.00V	○
F2.12	Lower limit value of A0			10.00V	○
F2.13	Input function of X1 selection	0: No function 1: Forward jogging 2: Reverse jogging 3: Forward rotation (FWD) 4: Reverse rotation (REV) 5: 3-wire control	0~27	3	×
F2.14	Input function of X2 selection	6: Coast to stop 7: External stop input (STOP) 8: External reset signal input (RST) 9: External Fault input 10: Increasing frequency setting (UP) 11: Decreasing frequency setting (DOWN) 12: Reserved	0~27	4	×
F2.15	Input function of X3 selection	13: Multi-step speed terminal S1 14: Multi-step speed terminal S2 15: Multi-step speed terminal S3 16: Shift the command to terminals 17: Shift the command to RS485	0~27	0	×
F2.16	Input function of X4 selection	18: DC brake 19: shift the frequency to AVI	0~27	0	×
F2.17	Input function of X5 selection	20: Shift the frequency to digital frequency 1 21: shift the frequency to digital frequency 2 22: Pulse frequency input (X5 only) 23: Counter reset	0~27	22	×

		24: Counter trigger 25: Timer reset 26: Timer trigger 27: ACC/DEC time option			
F2.18	Terminal FWD/REV control mode	0: 2-wire control mode 1 1: 2-wire control mode 2 2: 3-wire control mode 1 3: 3-wire control mode 2	0~3	0	×
F2.19	Terminal function check when power on	0: Terminal invalid 1: Terminal vaild	0~1	0	×
F2.20	Relay TA/TB/TC output	0: Invaild 1: ready for operation 2: In operation 3: zero speed running 4: External fault 5: The inverter fault 6: Detection amplitude value of frequency/speed (FAR)	0~14	5	○
F2.21	Y1 output	7: Detection electrical level of frequency/speed(FDT) 8: Upper limit output frequency arrival 9: Lower limit output frequency arrival 10: Overload pre-alarm 11: Running time arrival 12: setting count value arrival 13: Defined count value arrival 14: Auxiliary motor	0~14	0	○
F2.22	Relay R switching-on delay time	Corresponding delay time of the electrical level of change during the programmable relay R switching on and off.	0.0~255.0s	0.0s	×
F2.23	Relay TA/TB switching-off delay time				
F2.24	Amplitude value for frequency arrival (FAR) detection	When the output frequency is among the below or above range of the set frequency, the multi-function digital output terminal will output the signal of “frequency arrival”, the diagram shows below.	0.0Hz~15.0Hz	5.0Hz	○

F2.25	FDT level signal detection value	<p>When the output frequency exceeds the corresponding frequency of FDT electrical level, the multi-function digital output terminals will send signal of “frequency level detect FDT” [see P2.20~P2.21] until the output frequency decreases to a value lower than (FDT electrical level - FDT retention detection value) the corresponding frequency. The signal is invalid. The waveform diagram shows below:</p>	0.0Hz ~ upper limit freq.	10.0Hz	○
F2.26	FDT retention detection value		0.0~30.0Hz	1.0Hz	○
F2.27	UP/DOWN terminals control	This function code can modify the rate of the setting frequency of the terminal UP/DOWN, which means the rate amount for each second of terminal UP/DOWN shorted with terminal COM.	0.1~99.9Hz/s	1.0Hz/s	○
F2.28	Input terminal mode setting (X1~X5)	0: the terminal is switch (digital) input 2: the terminal is high pulse input.	0~1FH	0	○
F2.29	Xi active mode selection (X1~X5)	0: High level voltage active, which means Xi terminal becomes active when connected with COM, and inactive when disconnected. 1: Low level voltage active, which means Xi terminal becomes inactive when connected with COM, and active when disconnected.	0~1FH	0	○
F2.30	X1 filter coefficient -ient	<p>The parameter used to adjust the sensitivity of digital input terminals. Increasing the value properly can enhance the anti-interference of the signal, but weaken the sensitivity of the digital input. Each one unit equal to 2ms scan time.</p>	0~9999	5	○
F2.31	X2 filter coefficient -ient				○
F2.32	X3 filter coefficient -ient				○
F2.33	X4 filter coefficient -ient				○
F2.34	X5 filter coefficient -ient				○
F3-PID REFERENCE					

Code	Parameter	Parameter Instruction	Setting Range	Default	Property
F3.00	PID (proportion+ Integration+ Differentiation) reference setting option	<p>LED unit digit: PID output feature</p> <p>0: Invalid</p> <p>1: Positive feedback</p> <p>When feedback signal exceeds the PID reference value, the output frequency of the inverter will decrease to balance the PID. For example: the strain PID control during wrap-up.</p> <p>2: Negative feedback</p> <p>When the feedback is stronger than the PID reference value, the output frequency of the inverter will increase to balance the PID. For example: the strain PID control during wrap-down.</p> <p>LED tens:</p> <p>0: Keypad potentiometer reference PID feedback value modified by keypad.</p> <p>1: Digital reference PID feedback value modified by digital reference on parameter F3.01.</p> <p>2: Pressure reference (MPa, kg) Pressure feedback value modified on F3.01, 03.18.</p> <p>LED hundreds: PID feedback analog input channel</p> <p>0: AVI</p> <p>1: ACI</p> <p>LED thousands: PID Hibernation reference (water supply)</p> <p>0: Invalid</p> <p>1: Hibernate as the setting frequency 1: check P3.10~P3.13 for setting details</p> <p>2: Hibernate as the feedback pressure The same setting reference as option 0, if PID feedback value is in the setting range of P3.14, starting pressure of hibernation after hibernation delay time. The inverter will awake If the feedback value less than the setting value of hibernation awakes (when PID output is positive feedback).</p>	0000~2122	1010	×
F3.01	Digital setting value	<p>The function is valid when chosen PID digital (frequency) feedback channel (P3.00 tens on 1 or 2) . If the setting value tens digit is 2 on P3.00 which means pressure feedback, the unit of the value is same as P3.18</p>	0.0~100.0%	0.0%	○

F3.02	Feedback gain	To adjust the difference between feedback value and defined reference.	0.01~10.00	1.00	○
F3.03	Proportional gain (P)	PID adjustment speed depend on the setting of (P) and (Ti). If fast speed needed, to increase (P) , decrease(Ti). (TD).	0.01~5.00	2.00	○
F3.04	Time integration (Ti)		0.1~50.0s	1.0s	○
F3.05	Time differentiation (TD)		0.1~10.0s	0.0s	○
F3.06	Sampling Period (T)	This setting define the time of sampling period, the bigger value cause slow corresponding, but improve the signal disturbance.	0.1~10.0s	0.0s	○
F3.07	PID control deviation limit	The output of PID system is relative to the maximum deviation of the close loop reference. As shown in the diagram below, PID adjustor stops to work during the deviation limit. Set the function properly to adjust the accuracy and stability of the system.	0.0~20.0%	0.0%	○
F3.08	Close loop frequency preset	The PID running time and the frequency before PID be activated.	0.0~Max. freq.	0.0Hz	○
F3.09	PID running time preset		0.0~999.9s	0.0s	×
F3.10	Hibernation factor	If PID detection value is more than this parameter, and the output frequency reach to the lower limit, the inverter get into sleep mode (zero speed operation) after the delay time (P3.12); the factor is the percentage of PID reference?(P3.00)	0.0~150.0%	100.0%	○
F3.11	Waken factor	If detection value is less than this parameter, the inverter get wake up and start operate after the delay time reference (P3.13); the factor is the percentage of PID reference.	0.0~150.0%	90.0%	○
F3.12	Hibernation delay time	The delay time to hibernate	0.0~999.9s	100.0s	○
F3.13	Waken delay time	The delay time to wake up	0.0~999.9s	1.0s	○
F3.14	The deviation between hibernation and pressure feedback value	The parameter only be valid on “hibernate as the feedback pressure mode” (P3.00)	0.0~10.0%	0.5%	○
F3.15	Delay time of Pipe bust detection	The detection delay time of pipe bust	0.0~130.0s	30.0S	○

F3.16	High pressure detection factor	If feedback value is bigger than this setting, erro 'EPAO' display after the detection delay time value of F3.15. If the feedback value smaller, then the erro code will resume.	0.0~200.0%	150.0%	○
F3.17	Low pressure detection factor	This setting is the percentage of defined pressure reference. F3.17 is contrary above.	0.0~200.0%	50.0%	○
P3.18	Pressure setting	To defined pressure	0.00 ~ 99.99 (MPa、Kg)	10.00MPa	○

#### F4- ADVANCED REFERENCE

Code	Parameter	Parameter Instruction	Setting Range	Default	Property
F4.00	Rated voltage of motor	Motor reference setting	0~500V: 380V 0~250V: 220V	Default	×
F4.01	Rated current of motor		0.1~999.9A	Default	×
F4.02	Rated speed of motor		0~60000Krpm	Default	×
F4.03	Rated frequency of motor		1.0~999.9Hz	50.0Hz	×
F4.04	Stator resistor of motor	Strator resistor setting	0.001 ~ 20.000 Ω	Default	○
F4.05	Non-load current of motor	Non-load current setting.	0.1~【F4.01】	Default	×
F4.06	AVR function	0: Invalid 1: Valid during whole operation 2: Only valid before deceleration The Auto-Voltage Regulator(AVR) is able to eliminate the impact on the output voltage of the inverter caused by bus voltage fluctuation.	0~2	0	×
F4.07	Cooling fan control	0: Automatic mode 1: Full speed running on power (recommend for high temperature and humidity only)	0~1	0	○
F4.08	Auto fault reset time	Set the fault reset time by selecting this function. If the reset time exceeds this set value, the inverter will stop until be fixed manually. 0: No auto reset 10: always auto reset	0~10	0	×
4.09	The interval time of auto fault reset	The interval between the time when the fault occurs and the time when the reset action occurs.	0.5~25.0s	3.0s	×
F4.10	Braking threshold voltage	When the DC voltage of inverter is higher than threshold voltage(P4.10), the built-in braking unit will active. If braking resistor is connected, it will eliminate the exceeded voltage to reach the reference value(P4.11).	220v: 330~380/ 380v: 660~800V	350/780V	○
F4.11	Percentage of voltage to brake		10~100%	100%	○

#### P5- Portection reference

Code	Parameter	Parameter Instruction	Setting Range	Default	Property
F5.00	Protection setting	LED units: motor overload protection 0: Invalid 1: Valid LED tens: PID office protection 0: Invalid 1: Active to free stop LED hundreds: RS485 failure 0: active to free stopping 1: Keep running with alter	0000~1211	0001	×

		2: stopping by reference with alter LED thousands: Fluctuation control 0: Invalid 1: Valid									
F5.01	Over load protection coefficient	Times of motor overload $M = I_{out}/(I_n * K)$ $I_n$ is the rated current of the motor, $I_{out}$ is the output current of the inverter and $K$ is the motor protection coefficient. So, the bigger the value of $K$ is, the smaller the value of $M$ is. $W$	30%~110%	100%	×						
F5.02	Under voltage protection	Reference for the lower-limit voltage allowed when operation	50~280/ 50~480V	180/360V	×						
F5.03	Voltage control coefficient when decelerating	This parameter can change the level of over voltage control when decelerating.	0:Invalid, 1~255	1	×						
F5.04	Threshold voltage	The setting of the original bus voltage, adjust this parameter to break the load appropriately. The default value depends on model. The recommended setting range: <table border="1" data-bbox="427 817 946 887"> <tr> <td>Model</td> <td>220V</td> <td>380V</td> </tr> <tr> <td>Range</td> <td>350~400V</td> <td>660~850V</td> </tr> </table>	Model	220V	380V	Range	350~400V	660~850V	Check table	220V model : 375V  380V model : 790V	×
Model	220V	380V									
Range	350~400V	660~850V									
F5.05	Acceleration current limit	Acceleration current limit factor setting.	0:invalid, 1~99	10	×						
F5.06	Constant running current limit	Constant running current limit factor setting.	0:Invalid, 1~10	10	×						
F5.07	Automatic current limit	This parameter define the detection value of automatic current limit, the value compare to the percentage of the model current.	50%~250%	180%	×						
F5.08	Feedback offline detection value	The detection value is the percentage of PID reference, When value is smaller or equal to this setting, the inverter will active the reference of P5.00. When P5.08=0.0% means invalid value.	0.0~100.0%	0.0%	×						
F5.09	Feedback offline detection time	The lasting time before feedback offline protection happens.	0.1~999.9S	10.0s	×						
F5.10	Overload pre-alarm detection level	The output current of the inverter or the motor is exceed threshold of P11.09 and the lasting time is exceed P11.10, overload pre-alarm will be activated.	0~150%	120%	○						
F5.11	Overload pre-alarm detection time		0.0~15.0s	5.0s	×						
F5.12	Jogging priority reference	0:Invalid 1: Jogging control is prior during operation.	0~1	0	×						
F5.13	Motor frequency vibration control factor	When Motor current fluctuation may occur, active fluctuation control on P5.00, to only increase the value of P5.13 in normal circumstances. In some special occasions, the combine the reference of P5.13~P5.16 to get a better result.	0~200	30	○						
F5.14	Motor frequency vibration range factor		0~12	5	○						
F5.15	Vibration lower limit		0.0~【F5.16】	5.0Hz	○						

F5.16	Vibration upper limit		【 F5.15 】 ~ 【 F0.05 】	45.0Hz	○
F5.17	Current limit action selection	LED units: Action on Acceleration 0:Invalid 1:Valid LED tens: Action on deceleration 0: Invalid 1: Valid LED hundreds: Action on constant running 0: Invalid 1: Valid LED thousands: reserve	000~111	011	×
<b>F6-RS485 REFERENCE</b>					
F6.00	Local address	Set local communication address, the value of this driver is the unique in the communication net. Reference 0 is master driver.	0~247	1	×
F6.01	MODBUS communication reference	LED units: Baud ratio reference 0: 9600BPS 1: 19200BPS 2: 38400BPS LED tens: Digital bit checkout 0: No check 1: Even check 2: Odd check LED hundreds: Communication respond 0: General respond 1: respond to slave address only 2: No respond 3: salve does not respond to the free running stop command from master under broadcast mode LED thousands: Reserve	0000~0322	0000	×
F6.02	Communication timeout	When the function code value is 0.0, the communication timeout parameter is invalid. If the interval time between two communication exceeds timeout set value, the driver will follow the reference of P5.00 whether to keep running or stop.	0.1~100.0s	10.0s	×
F6.03	Response delay	The interval time between the interval time when the drive receive the data and set tit to the upper monitor. If the answer delay is shorter than the processing time.	0~200ms	5ms	×
F6.04	Coordinate control factor	This factor is the ratio of inverter running frequency received from RS485, the actual frequency is the result of this factor value multiply by command frequency of RS485. In the coordinate control mode can set different ratio of each drivers.	0.01~10.00	1.00	○
<b>F7- THE OTHERS</b>					
<b>Code</b>	<b>Parameter</b>	<b>Parameter Instruction</b>	<b>Setting Range</b>	<b>Default</b>	<b>Property</b>

F7.00	Counter and timer mode	LED tens: Counter cycle finish 0: One cycle counter, stop operation 1: One cycle, keep operation 2: Multi-cycle, stop operation 3: Multi-cycle, keep operation LED tens: reserved. LED hundreds: Timer cycle finish 0: One cycle counter, stop operation 1: One cycle, keep operation 2: Multi-cycle, stop operation 3: Multi-cycle, keep operation LED thousands: reserved	000~303	103	×
F7.01	Counter restore point	To set the counter restore point.	【F7.02】~9999	1	○
F7.02	Counter restore check point	To set the counter restore check point	0~ 【F7.01】	1	○
F7.03	Timer setting	To set the value of timer.	0~9999s	0s	○
F7.04	Lower frequency of External pulse input X5	To set the upper and lower limit of external pulse input X5.	0.00~ 【F7.14】	0.00KHz	○
F7.05	Upper frequency of External pulse input X5		【F7.13】 ~ 99.99KHz	20.00KHz	○
P7.06	Relevant upper limit frequency of X5	To set the external pulse input relevant value, this value is the percentage of the maximum of the output frequency.	-100.0%~ 100.0%	0.0%	○
P7.07	Relevant lower limit frequency of X5		-100.0%~ 100.0%	100.0%	○
<b>F8 - PARAMETER MANAGEMENT AND DISPLAY</b>					
Code	Parameter	Parameter Instruction	Setting Range	Default	Property
F8.00	Operation monitoring Parameter selection	For example: when P8.00=2, the screen display correspond to the selection of output voltage (d-02).	0~26	0	○
F8.01	Stop monitoring parameter selection	For example: when P8.01=3, the screen display correspond to selection of the bus voltage.	0~26	1	○
F8.02	Motor speed display factor	The parameter can correct the difference between displayed speed and real speed, no affection to the real speed.	0.01~99.99	1.00	○
F8.03	Initialize parameter	0: No change 1: Factory setting All parameter reset to factory 2: empty all error records Clean up all the error records(d-19~d-24), the reference will return to 0 after that.	0~2	0	×
F8.04	Keypad JOG function setting	0: JOG 1: Forward / Reverse 2: clean up frequency set up by ▲/▼ 3: Reverse when RUN is Forward.	0~3	0	×

F8.05	Motor slip compensation gain	0: Invalid 1: Valid This function code is used to compensate the change of the rotation speed caused by load during compensation SVPWM control to improve the rigidity of the motor.	0~1	0	×
-------	------------------------------	--	-----	---	---

# Communicating with PLC

## 7.1 RTU mode and format introduction

The inverter support communication with Modbus protocol over RTU (Remote Terminal Unit) mode on RS485, 8bit byte in the message include two 4Bit hex characters in every control word. Compare with ASCII mode, the mode can send more data at the same baud rate, all the data must be sending continuously.

## 7.2 RTU communication frame format

### 7.2.1 Code system:

- 8 digital bit, every 8 bit frame includes two hex characters (0~9, A~F).
- 1 start bit, 8 digital bit , the minimum valid bit can be send firstly.
- 1 even/odd check bit, If there is no checkout, the even/odd check bit is inexistent.
- 1 end bit (with checkout), 2 Bit(no checkout).

### Error detection field

- **CRC (Cyclic Redundancy Check).**

### 7.2.2 The data format is shows below:

With check out - 11-bit characters frame(Bit 1~Bit 8 are digital bits)

Start	Bit 1	Bit 2	Bit 3	Bit 4	Bit 5	Bit 6	Bit 7	Bit 8	Check bit	Stop
-------	-------	-------	-------	-------	-------	-------	-------	-------	-----------	------

No checkout - 10-bit characters frame(Bit 1~Bit 8 are digital bits)

Start	Bit 1	Bit 2	Bit 3	Bit 4	Bit 5	Bit 6	Bit 7	Bit 8	Stop
-------	-------	-------	-------	-------	-------	-------	-------	-------	------

## 7.3 Supported function code:

Function code	Function detail
03H	Reading holding register
06H	Writing single register

## 7.4 Communication protocol address mapping table:

Function	Modbus	Setting	R/W
Control mode	2000H	0001H: Stop	W
		0012H: Forward	
		0013H: Forward jogging	
		0022H: Reverse	
		0023H: Reverse jogging	
Communication address of frequency	2001H	Frequency Range: -10000~10000。 (The setting frequency corresponds to percentage of the maximum frequency, range: -100.00%~100.00%)	W
Communication control mode	2002H	0001H: External faulty input	W
		0002H: Fault reset	

Status of the inverter	2102H	Max. frequency (unit: 0.01Hz)	R
	2103H	Output frequency (Unit: 0.01Hz)	R
	2104H	Input current (Unit: 0.1A)	R
	2105H	Input voltage (Unit: 0.1V)	R
	2106H	Output voltage (Unit: 0.1V)	R
	210DH	Inverter's temperature (Unit: 0.1℃)	R
	210EH	PID feedback (Unit: 0.01mA/V)	R
	210FH	PID reference (Unit: 0.01mA/V)	R
Status of the inverter	2101H	Bit0: Run Bit1: Stop Bit2: Jogging Bit3: Forward Bit4: Reverse Bit5~Bit7: Reserved Bit8: Communication control Bit9: Terminal control Bit10: R485 operate Channel Bit11: Reference lock Bit12: Operating Bit13: Jogging reference set Bit14~Bit15: Reserved	R
Fault code	2100H	00: Normal 01: IGBT fault 02: Overvoltage 03: Over Temperature 04: Inverter overload 05: Motor overload 06: External Falut 07~09: Reserved 10: Overcurrent during accelerating 11: Overcurrent during decelerating 12: Overcurrent during constant running 13: reserved 14: Undervoltage	R
Setting reference address	0000H~ 0804H	For example: 0000H correspond to F0.00, 050AH correspond to F5.10, 0804H correspond to F8.04	R/W

# Maintenance and care

Changes in the operating environment of the inverter, such as the effects of temperature, humidity, smoke, etc., and the aging of components inside the inverter may cause various faults in the inverter. Therefore, during the storage and use, the inverter must be inspected daily and regularly maintained.

## 8.1 Daily Maintenance

After start the inverter, please notice below things:

- (1) Whether the motor have abnormal sound and vibration.
- (2) Whether the inverter and motor are overheated.
- (3) Whether the temperature of the environment is too high.
- (4) Whether the load ammeter the same as usual.
- (5) Whether the cooling fan of inverter is running normally.

## 8.2 Regular Maintenance and Routine Care

### 8.2.1 Regular Maintenance

According to the usage condition, the user can make regular routine inspections on the inverter in a short period of time or 3-6 months to avoid hidden troubles and ensure long-term performance and stable operation. When the inverter is inspected, be sure to turn off the power. The check can only be continued after the monitor has no display and the main circuit power indicator is off.

Here are 7 things you are able to inspect:

- (1) Whether the sub-screw of control section is loose, tighten it with a suitable size screwdriver.
- (2) Whether there is contact failure in the main circuit terminals, whether there are any signs of overheating at the cable or copper bar connection, screws, etc.
- (3) Whether the power cable and the control wire are damaged, and check the external insulation layer has cracks or cuts shall be the focus of the inspection.
- (4) Whether the connection between the power cable and the cold-pressed joint is loose, and check the insulating explosive belt at the joint is aging or falling off.
- (5) Thoroughly clean the dust on printed circuit boards, air ducts, etc., and take anti-static measures when cleaning.
- (6) For the insulation test of the inverter, the power supply of the inverter and all the connections between the inverter and the motor must be removed first, and make sure all the main circuit input and output terminals are reliably shorted by the wires, then grounded. test.

Please use a qualified 500V standard megohm (or the corresponding voltage level of the insulation tester); do not use a faulty instrument. It is strictly forbidden to connect the single main circuit terminal to the ground for insulation test, otherwise there will be a danger of damage to the inverter.

Do not perform insulation test on the control terminals, otherwise the inverter will be damaged.

After testing, remember to remove all wires from the shorted circuit terminals.

- (7) If the motor is tested for insulation, the wire connected between the motor and the inverter must be completely disconnected before the motor is tested separately. Otherwise there will be a danger of damage to the inverter.

### 8.2.2 Routine Care

In order to make the inverter work normally for a long time, the service life of the internal electronic components of the inverter must be regularly maintained. The use of inverter electronic components varies depending on the conditions of use. The below maintenance period of the inverter is just for reference.

Name of Components	Standard Change Period
--------------------	------------------------

Cooling Fan	2~3 Years
Electrolytic Capacitors	4~5 Years
Printer Circuit Board	5~8 Years

**MOLLOM<sup>®</sup>**

