

AIR FRYER

USER'S GUIDE

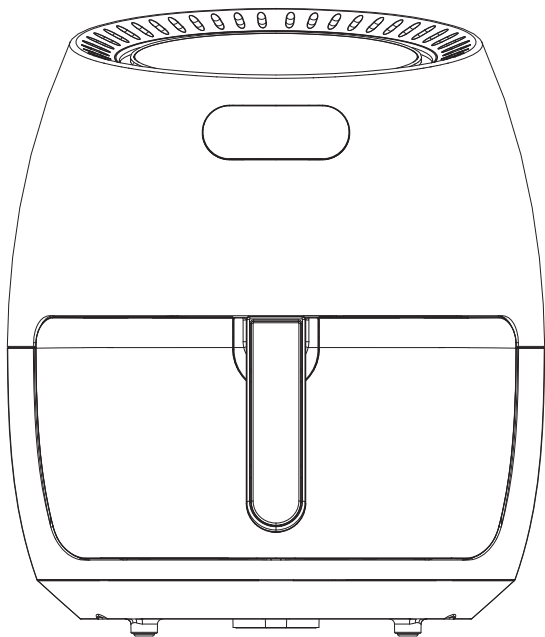

Model No.: HF-1088TS (UEA023)

Introduction

Thank you for buying this top quality air fryer. You will now be able to cook a wide assortment of food in a healthier manner – with little or no oil!

The air fryer uses hot air, in combination with high-speed air circulation, and a top grill to prepare your dishes quickly and easily. The ingredients are heated from all sides, at once, and there is no need to add oil in most cases.

General description

1. Basket
2. Basket handle
3. Power-on knob
4. Pause knob
5. Timer control (0-30min.)
6. Temperature control (80-200°C)
7. Menu for cooking system (Touch to change and choose cooking system)
8. Air outlet openings
9. Mains cord

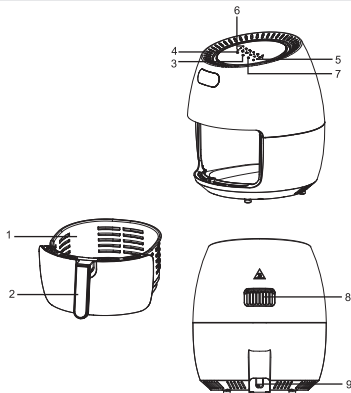

Important

Read this user manual carefully, before you use the appliance, and keep it safely for future reference.

Danger

- Never immerse or rinse the housing and its heating elements into water for they are electrical components.
- Do not let water or other liquids enter the appliance to prevent electric shock.

- Always put the ingredients to be fried in the basket to prevent it from coming into contact with the heating elements.
 - Do not cover the air inlet or the air exhaust while the appliance is operating.
 - Do not fill the frying tray with oil as this may cause a fire hazard.
 - Never touch the inside of the appliance while it is operating.
 - Check that the voltage indicated on the appliance corresponds to the local mains voltage in your country before connecting the appliance.
 - Do not use the appliance if the plug, the power cord or the appliance itself is damaged.
 - If the power cord is damaged, you must have it replaced at a service center authorized by a qualified persons in order to avoid a hazard.
 - Never touch the inside of the appliance while it is operating.
 - Check whether the voltage indicated on the appliance corresponds to the local mains voltage in your country before you connect the appliance.
 - Do not use the appliance if the plug, the power cord or the appliance itself is damaged.
 - If the power cord is damaged, you must have it replaced at a service center authorized by similarly qualified persons in order to avoid a hazard.
 - This appliance is not suitable for children or people who are either physically or mentally handicapped or who lack of experience and knowledge. Should you want anyone else to use the appliance, that person should be properly guided on its use.
 - Keep the appliance and its mains cord out of the reach of children when the appliance is switched on or is cooling down.
 - Keep the mains cord away from hot surfaces.
 - Do not plug in the appliance or operate the control panel with wet hands.
 - Only connect the appliance to an earthed wall socket. Always make sure that the plug is inserted into the wall socket properly.
 - Never connect this appliance to an external timer switch.
 - Do not place the appliance on or near combustible materials such as a tablecloth or curtains.
 - Do not place the appliance against a wall or against other appliances. Leave at least 10cm of free space at the back, sides, and above the appliance. Do not place anything on top of the appliance.
 - Do not use the appliance for any purpose other than described in this manual.
 - Do not let the appliance operate unattended.
 - During hot air frying, hot steam is released through the air exhaust. Keep your hands and face at a safe distance from the steam and from the air exhaust.
- Also be careful of hot steam and hot air when you remove the frying tray from the appliance.
- The surface below the appliance may become hot during use.
 - Immediately unplug the appliance if you see dark smoke coming out of the appliance. Wait until the smoke emission stops before you remove the frying tray from the appliance.

Caution

- Place the appliance on a horizontal, level and stable surface.
- This appliance is intended for normal household use only. It is not intended for use in environments such as staff kitchens, offices, farms or other work environments. Nor is it intended to be used by clients in hotels or other similar environments.
- If the appliance is used improperly or if it is not used according to the instructions in the user manual, the warranty becomes invalid and seller refuses any liability for any damage that may be caused.
- Always unplug the appliance after use.
- Let the appliance cool down for approximately 30 minutes before you handle or clean it.
- Remove burnt remnants.

Automatic switch-off

The appliance has a built-in timer, it will automatically shut down the appliance when it has reached zero. You can manually switch off the appliance too. It will automatically shut down the appliance in 20 seconds.

Before first use

1. Remove all packing material.
2. Remove any stickers or labels from the appliance – other than the rating label.
3. Thoroughly clean the basket and frying tray with hot water and some liquid washing soap with a non-abrasive sponge.
Note: You can also clean these parts in the dishwasher.
4. Wipe the inside and outside of the appliance with a piece of moist cloth.

Preparing for use

1. Place the appliance on a stable, horizontal and level surface that is also heat resistant.
2. Place the basket in the frying tray properly.
Do not fill the frying tray with oil or any other liquid.
Do not put anything on top of the appliance. This disrupts the airflow and affects the air-frying result.

Using the appliance

1. Place the ingredients in the basket, and then push the basket into the appliance.
 2. Select the proper function and temperature for the ingredients.
8 functions are provided: CHIP, CHICKEN, STEAK, SHRIMP, MEAT, CAKE, PIZZA and FISH.
Press "Menu" to select the proper function according to the ingredients and then press "Start", the appliance will begin to run and heat the ingredients.
Press "Menu" continuously to change and choose the cooking function.
- Notes:
- There are two keys (TIME '+' & '-') in the control panel which can adjust time setting – Increase/Decrease 1 minute per press or increase/decrease rapidly by long pressing. There are two keys (TEMP '+' & '-') in the control panel which can adjust temperature setting - Increase/Decrease 5 degrees per press or increase/decrease rapidly by long pressing.
3. Press "Alarm Clock" and TIME '+' & '-' to set a countdown alarm.
 4. Some ingredients require to shake halfway during the preparation time (see section 'settings' in this chapter). Pull the basket out of the appliance by the handle and shake it. Then slide the basket back into the air fryer.
 5. When you hear the timer bell, the set preparation time has been reached. Pull the basket out of the appliance and place it on a heat-resistant holder.
 6. Check if the ingredients are ready. If the ingredients are not ready yet, simply slide the basket back into the appliance and adjust the settings of TIME&TEMP, then press the Start key to run the appliance.
 7. To take out the ingredients, please lift the ingredients from the basket.
Note: Do not turn the basket over, the oil collected on the bottom will leak onto the ingredients.
 8. When a batch of ingredients is ready, the air fryer is instantly ready for preparing another batch.

Tips

1. Small ingredients usually require a slightly shorter preparation time than larger ingredients.
2. Shaking smaller ingredients halfway during the preparation time optimizes the end result and can help prevent unevenly fried ingredients.
3. Add some oil to fresh potatoes and fry your ingredients for another few minutes for a crispy result.
4. Do not prepare extremely greasy ingredients such as sausages in the air fryer.
5. Snacks can be prepared in an oven or in the air fryer.
6. The optimal amount when preparing crispy fries is 500g.
7. Use pre-made dough to get snacks quickly and easily. Pre-made dough also requires a shorter preparation time than home-made dough.
8. Place a baking tin or oven dish in the fryer basket if you want to bake a cake, a quiche or if you want to fry fragile ingredients or filled ingredients.
9. To heat ingredients, set the temperature to 150°C for up to 10 minutes.
10. To take out large or fragile ingredients, lift the ingredients from the basket by a pair of tongs.

Settings

This table below will help you select the basic settings for the ingredients.
Note: Keep in mind that these settings are indications. As ingredients differ in origin, size, shape and brand, we cannot guarantee the best setting for your ingredients.

	Min-Max Amount (g)	Time (min.)	Temperature (°C)	Shake	Extra information
--	--------------------	-------------	------------------	-------	-------------------

Potatoes & fries

Thin frozen fries	450-1000	9-16	200	Shake	
Thick frozen fries	450-1000	11-20	200	Shake	
Home-made fries (8x8mm)	450-1200	16-20	200	Shake	add 1/2 tbsp of oil
Home-made potato wedges	450-1200	18-22	180	Shake	add 1/2 tbsp of oil
Home-made potato cubes	450-1100	12-18	180	Shake	add 1/2 tbsp of oil
Rösti	350	15-18	180		
Potato gratin	750	15-18	200		

Meat & Poultry

Steak	150-750	8-12	180		
Pork chops	150-750	10-14	180		
Hamburger	150-750	7-14	180		
Sausage roll	150-750	13-15	200		
Drumsticks	150-750	18-22	180		
Chicken breast	150-750	10-15	180		

Snacks

Spring rolls	150-600	8-10	200	Shake	Use oven-ready
Frozen chicken Nuggets	150-750	6-10	200	Shake	Use oven-ready
Frozen fish fingers	150-600	6-10	200		Use oven-ready
Frozen Bread-crumbed cheese snacks	150-600	8-10	180		Use oven-ready
Stuffed vegetables	150-600	10	160		Use oven-ready

Baking

Cake	450	20-25	160		Use baking tin
Quiche	600	20-22	180		Use baking tin
Muffins	450	15-18	200		Use baking tin
Sweet snacks	60	20	160		Use baking tin

Note: Add 3 minutes to the preparation time before you start frying if the appliance is cold.

Cleaning

Clean the appliance after every use.

The frying tray, basket and the inside of the appliance have a non-stick coating. Do not use metal kitchen utensils or abrasive cleaning materials to clean them, as this may damage the non-stick coating.

Clean the appliance after every use.

The frying tray, basket and the inside of the appliance have a non-stick coating. Do not use metal kitchen utensils or abrasive cleaning materials to clean them, as this may damage the non-stick coating.

1. Remove the mains plug from the wall socket and let the appliance cool down.

Note: Remove the frying tray to let the air fryer cool down more quickly.

2. Wipe the outside of the appliance with a piece of moist cloth.

3. Clean the frying tray and basket with hot water, some washing liquid soap and a non-abrasive sponge.

You can use a washing liquid to remove any remaining dirt.

Note: The frying tray and basket are dishwasher-safe.

Tip: If remnants are stuck to the basket, or at the bottom of the frying tray, fill the frying tray with hot water and with some washing liquid soap. Put the basket in the frying tray and let the frying tray and the basket soak for approximately 10 minutes.

1. Clean the inside of the appliance with hot water and a non-abrasive sponge.

2. Clean the heating element with a cleaning brush to remove any food residue.

Storage

1. Unplug the appliance and let it cool down.

2. Make sure all parts are clean and dry.

Troubleshooting

Problem	Possible cause	Solution
The air fryer does not work	The air fryer is not plugged in.	Plug in a wall socket.
	You have not set the timer.	Turn the timer knob to the required preparation time to switch on the appliance.
The ingredients fried with the air fryer are not done.	The amount of the ingredients in the basket is too much.	Put smaller batches of ingredients in the basket. Smaller batches can be fried more evenly.
	The set temperature is too low.	Turn the temperature control knob to the required temperature setting (see section 'Settings').
	The preparation time is too short.	Turn the timer knob to the required preparation time (see section 'Settings').

Problem	Possible cause	Solution
The ingredients are fried unevenly in the air fryer.	Certain types of the ingredients need to be shaken halfway through the preparation time.	Ingredients that lie on top of or across each other (e.g. fries) need to be shaken halfway through the preparation time (see section 'Settings').
Fried snacks are not crispy when they come out of the air fryer.	You used a type of snacks meant to be prepared in a traditional deep fryer.	Use oven snacks or lightly brush some oil onto the snacks for a crispier result.
I cannot slide the bowl into the appliance properly.	There is too much food in the basket.	The amount of food in the basket shouldn't be beyond the Max amount indicated in the table on the earlier page.
	The basket is not correctly placed in the bowl.	Push the basket down into the bowl until you hear a click.
White smoke comes out of the appliance.	You are preparing greasy ingredients.	Pay attention that the temperature should be well-controlled to be under 180°C when you fry some greasy ingredients in the air fryer.
	The basket still contains greasy residues from previous use.	White smoke is caused by grease heating up in the basket. Make sure you clean the basket properly after use each time.
Fresh potato fries are fried unevenly in the air fryer.	You did not soak the potato sticks properly before you fried them.	Soak the potato sticks in a bowl of water for at least 30 minutes; take them out and dry them with kitchen paper.
	You did not use the right potato type.	Use fresh potatoes and make sure they stay firm during frying.
Fresh potato fries are not crispy when they come out of the air fryer.	The crispiness of the fries depends on the amount of oil and water in the fries.	Make sure you dry the potato sticks properly before you coat them with oil.
		Cut the potato into thinner sticks for a crispier result.
		Add some more oil slightly for a crispier result.

After-sales service

This product enjoys two-year warranty. Within a limited warranty or two full years from purchase date, clients can contact the seller to claim maintenance service for free if there are damages caused by product's quality.

The faults caused by accidental damage, unauthorized repair, improper storage and secondary sales of the products are not included in the warranty.

Copyright

This publication, including all photographs, illustrations and introduction images, is protected under international copyright laws, with all rights reserved. Neither this manual, nor any of the material contained herein, may be reproduced without written consent of the author.

Disclaimer

The information in this document is subject to change without notice. The manufacturer makes no representations or warranties with respect to the contents hereof and specifically disclaims any implied warranties of merchantability or fitness for any particular purpose. The manufacturer reserves the right to revise this publication and to make changes from time to time in the content hereof without obligation of the manufacturer to notify any person of such revision or changes.

This product specification describes the composition and respectively the properties of our product to the best of our knowledge. We make every effort to ensure that this User's Manual is accurate and disclaim liability for any inaccuracies or omissions that may have occurred.

If you find information in this manual that is incorrect, misleading, or incomplete, we would appreciate your comments and suggestions.