

vtech®

Go to www.vtechphones.com (US) to register your product for enhanced warranty support and latest VTech product news.

SN5147

Go to phones.vtechcanada.com (Canada) for the latest VTech product news.

Amplified Corded/Cordless Answering System
with Big Buttons and Display



Scan the QR code for
support information



(US)



(CA)



User guide

Congratulations

on purchasing your new VTech product. Before using this telephone, please read **Important safety instructions**.

This quick start guide provides you with basic installation and use instructions. A limited set of features are described in abbreviated form. Please refer to the online user's manual for a full set of installation and operation instructions at **www.vtechphones.com**. In Canada, please visit **phones.vtechcanada.com**.

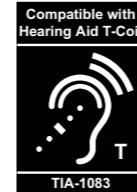

Telephones identified with this logo have reduced noise and interference when used with most T-coil equipped hearing aids and cochlear implants. The TIA-1083 Compliant Logo is a trademark of the Telecommunications Industry Association. Used under license.



The ENERGY STAR® program (www.energystar.gov) recognizes and encourages the use of products that save energy and help protect our environment. We are proud to mark this product with the ENERGY STAR® label indicating it meets the latest energy efficiency guidelines.



Important safety instructions

When using your telephone equipment, basic safety precautions should always be followed to reduce the risk of fire, electric shock and injury, including the following:

1. Read and understand all instructions.
2. Follow all warnings and instructions marked on the product.
3. Use only with UL listed Bluetooth devices.
4. Unplug this product from the wall outlet before cleaning. Do not use liquid or aerosol cleaners. Use a damp cloth for cleaning.
5. **CAUTION:** Do not install the telephone base at a height above 2 meters.
6. Do not use this product near water such as near a bath tub, wash bowl, kitchen sink, laundry tub or a swimming pool, nor in a wet basement or shower.
7. Do not place this product on an unstable table, shelf, stand or other unstable surfaces.
8. Avoid placing the telephone system in places with extreme temperature, direct sunlight, or other electrical devices. Protect your phone from moisture, dust, corrosive liquids and fumes.
9. Slots and openings in the back or bottom of the telephone base and handset are provided for ventilation. To protect them from overheating, these openings must not be blocked by placing the product on a soft surface such as a bed, sofa or rug. This product should never be placed near or over a radiator or heat register. This product should not be placed in any area where proper ventilation is not provided.
10. This product should be operated only from the type of power source indicated on the marking label. If you are not sure of the type of power supply in your home or office, consult your dealer or local power company.
11. Do not allow anything to rest on the power cord. Do not install this product where the cord may be walked on.
12. Never push objects of any kind into this product through the slots in the telephone base or handset because they may touch dangerous voltage points or create a short circuit. Never spill liquid of any kind on the product.
13. To reduce the risk of electric shock, do not disassemble this product, but take it to an authorized service facility. Opening or removing parts of the telephone base or handset other than specified access doors may expose you to dangerous voltages or other risks. Incorrect

reassembly can cause electric shock when the product is subsequently used.

14. Do not overload wall outlets and extension cords.
15. Unplug this product from the wall outlet and refer servicing to an authorized service facility under the following conditions:
 - When the power supply cord or plug is damaged or frayed.
 - If liquid has been spilled onto the product.
 - If the product has been exposed to rain or water.
 - If the product does not operate normally by following the operating instructions. Adjust only those controls that are covered by the operation instructions. Improper adjustment of other controls may result in damage and often requires extensive work by an authorized technician to restore the product to normal operation.
 - If the product has been dropped and the telephone base and/or handset has been damaged.
 - If the product exhibits a distinct change in performance.
16. Avoid using a telephone (other than cordless) during an electrical storm. There is a remote risk of electric shock from lightning.
17. Do not use the telephone to report a gas leak in the vicinity of the leak. Under certain circumstances, a spark may be created when the adapter is plugged into the power outlet, or when the handset is replaced in its cradle. This is a common event associated with the closing of any electrical circuit. The user should not plug the phone into a power outlet, and should not put a charged handset into the cradle, if the phone is located in an environment containing concentrations of flammable or flame-supporting gases, unless there is adequate ventilation. A spark in such an environment could create a fire or explosion. Such environments might include: medical use of oxygen without adequate ventilation; industrial gases (cleaning solvents; gasoline vapors; etc.); a leak of natural gas; etc.
18. Only put the handset of your telephone next to your ear when it is in normal talk mode.
19. The power adapter is intended to be correctly oriented in a vertical or floor mount position. The prongs are not designed to hold the plug in place if it is plugged into a ceiling, under-the-table or cabinet outlet.
20. For pluggable equipment, the socket-outlet shall be installed near the equipment and shall be easily accessible.

21.   **CAUTION:** Use only the batteries indicated in this manual. There may be a risk of explosion if a wrong type of battery is used for the handset. Use only the supplied rechargeable batteries or replacement batteries (BT205662) for the handset. Do not dispose of batteries in a fire. They may explode. Disposed of used batteries according to the instruction.
 - Do not use the battery in following conditions:
 - » High or low extreme temperature during use, storage or transportation.
 - » Replacement of a battery with an incorrect type that can defeat a safeguard.
 - » Disposal of a battery into fire or a hot oven, or mechanically crushing or cutting of a battery, that can result in an explosion.
 - » Leaving a battery in an extremely high temperature surrounding environment that can result in an explosion or the leakage of flammable liquid or gas.
 - » A battery subjected to extremely low air pressure that can result in an explosion or the leakage of flammable liquid or gas.
22. Use only the adapter included with this product. Incorrect adapter polarity or voltage can seriously damage the product.
23. The applied nameplate is located at the bottom or near of the product.

SAVE THESE INSTRUCTIONS

Battery

- Use only the battery provided or equivalent. To order a replacement, visit our website at www.vtechphones.com or call 1 (800) 595-9511. In Canada, go to phones.vtechcanada.com or call 1 (800) 267-7377.
- Do not dispose of the battery in a fire. Check with local waste management codes for special disposal instructions.
- Do not open or mutilate the battery. Released electrolyte is corrosive and may cause burns or injury to the eyes or skin. The electrolyte may be toxic if swallowed.
- Exercise care in handling batteries in order not to create a short circuit with conductive materials.
- Charge the battery provided with this product only in accordance with the instructions and limitations specified in this manual.

Precautions for users of implanted cardiac pacemakers
Cardiac pacemakers (applies only to digital cordless

telephones):

Wireless Technology Research, LLC (WTR), an independent research entity, led a multidisciplinary evaluation of the interference between portable wireless telephones and implanted cardiac pacemakers. Supported by the U.S. Food and Drug Administration, WTR recommends to physicians that:

Pacemaker patients

- Should keep wireless telephones at least six inches from the pacemaker.
- Should NOT place wireless telephones directly over the pacemaker, such as in a breast pocket, when it is turned ON.
- Should use the wireless telephone at the ear opposite the pacemaker.

WTR's evaluation did not identify any risk to bystanders with pacemakers from other persons using wireless telephones.

About cordless telephones

- **Privacy:** The same features that make a cordless telephone convenient create some limitations. Telephone calls are transmitted between the telephone base and the cordless handset by radio waves, so there is a possibility that the cordless telephone conversations could be intercepted by radio receiving equipment within range of the cordless handset. For this reason, you should not think of cordless telephone conversations as being as private as those on corded telephones.
- **Electrical power:** The telephone base of this cordless telephone must be connected to a working electrical outlet. The electrical outlet should not be controlled by a wall switch. Calls cannot be made from the cordless handset if the telephone base is unplugged, switched off or if the electrical power is interrupted.
- **Potential TV interference:** Some cordless telephones operate at frequencies that may cause interference to televisions and VCRs. To minimize or prevent such interference, do not place the telephone base of the cordless telephone near or on top of a TV or VCR. If interference is experienced, moving the cordless telephone farther away from the TV or VCR often reduces or eliminates the interference.
- **Rechargeable batteries:** Exercise care in handling batteries in order not to create a short circuit with conducting material such as rings, bracelets and keys.

The battery or conductor may overheat and cause harm. Observe proper polarity between the battery and the battery charger.

- **Nickel-metal hydride rechargeable batteries:** Dispose of these batteries in a safe manner. Do not burn or puncture the battery. Like other batteries of this type, if burned or punctured, they could release caustic material which could cause injury.

For C-UL compliance only

Mesures de sécurité importantes

Afin de réduire les risques d'incendie, de blessures corporelles ou d'électrocution, suivez toujours ces mesures préventives de base lorsque vous utilisez votre téléphone :

1. Lisez et comprenez bien toutes les instructions.
 2. Observez toutes les instructions et mises en garde inscrites sur l'appareil.
 3. N'utilisez qu'avec des dispositifs Bluetooth homologués par UL.
 4. Débranchez ce téléphone de la prise murale avant de le nettoyer. N'utilisez pas de nettoyeurs liquides ni en aérosol. N'utilisez qu'un chiffon doux et légèrement humecté.
 5. **ATTENTION:** Ne pas installer le socle téléphonique à une hauteur supérieure à 2 mètres.
 6. N'utilisez pas ce produit près de l'eau, tel que près d'un bain, d'un lavabo, d'un évier de cuisine, d'un bac de lavage ou d'une piscine, ou dans un sous-sol humide ou sous la douche.
 7. Ne déposez pas ce téléphone sur un chariot, support ou table chancelants. L'appareil pourrait tomber et être sérieusement endommagé.
 8. Évitez d'installer le système téléphonique dans les endroits soumis à une température extrême, à la lumière directe du soleil ou à proximité immédiate d'autres appareils électriques ou électroniques. Protégez votre téléphone contre les sources d'humidité, la poussière, les vapeurs et les liquides corrosifs.
 9. Le boîtier de l'appareil est doté de fentes et d'ouvertures d'aération situées à l'arrière ou en dessous. Afin d'empêcher la surchauffe, ces ouvertures ne doivent pas être obstruées en plaçant l'appareil sur un lit, divan, tapis ou autre surface similaires. Ne placez pas cet appareil à proximité d'un élément de chauffage ni d'une plinthe électrique. De plus, ne l'installez pas dans une unité murale ou un cabinet fermé qui ne possède pas d'aération adéquate.
10. Ne faites fonctionner cet appareil qu'avec le type d'alimentation indiqué sur les étiquettes de l'appareil. Si vous ne connaissez pas le voltage de votre maison, consultez votre marchand ou votre fournisseur d'électricité.
 11. Ne déposez rien sur le cordon d'alimentation. Installez cet appareil dans un endroit sécuritaire, là où personne ne pourra trébucher sur la ligne d'alimentation ni le cordon téléphonique modulaire.
 12. N'insérez jamais d'objets à travers les fentes et ouvertures de cet appareil, car ils pourraient toucher à des points de tension dangereux ou court-circuiter des pièces, ce qui constituerait un risque d'incendie ou d'électrocution. N'échappez pas de liquides dans l'appareil.
 13. Afin de réduire les risques d'électrocution, ne démontez pas l'appareil, mais apportez-le plutôt à un centre de service qualifié s'il doit être réparé. En enlevant le couvercle, vous vous exposez à des tensions dangereuses ou autres dangers similaires. Un remontage inadéquat peut être à l'origine d'une électrocution lors d'une utilisation ultérieure de l'appareil. Débranchez l'appareil avant de procéder au nettoyage. Utilisez un chiffon humide et doux.
 14. Ne surchargez pas les prises de courant et les rallonges.
 15. Débranchez cet appareil de la prise de courant et communiquez avec le département de service à la clientèle de VTech dans les cas suivants :
 - Lorsque le cordon d'alimentation est endommagé ou écorché.
 - Si du liquide a été échappé dans l'appareil.
 - Si l'appareil a été exposé à une source d'humidité telle que la pluie ou l'eau.
 - Si le produit ne fonctionne pas normalement en respectant les instructions de fonctionnement. Réglez uniquement les commandes indiquées dans le les instructions de fonctionnement. Les réglages incorrects des autres commandes pourraient provoquer un dommage qui pourrait exiger un travail exhaustif de la part d'un technicien autorisé afin de rétablir le fonctionnement normal de l'appareil.
 - Si le produit a été échappé et que le socle et/ou le combiné a été endommagé.
 - Si le produit affiche une nette diminution de sa performance.
 16. Évitez d'utiliser un téléphone (autre qu'un sans fil) pendant un orage. Les éclairs peuvent être à l'origine d'une électrocution.
 17. N'utilisez pas le téléphone pour rapporter une fuite de

gaz à proximité de la fuite. En certaines circonstances, une flammèche pourrait être provoquée lorsque l'adaptateur est branché à une prise de courant, ou lorsque le combiné est déposé sur le socle. Ceci est un événement commun associé à la fermeture d'un circuit électrique. L'utilisateur ne devrait pas brancher le téléphone à une prise de courant, et ne devrait pas déposer le combiné chargé sur le socle, si le téléphone se trouve à proximité d'un endroit comportant des concentrations de gaz inflammables, à moins que la ventilation soit adéquate. Une flammèche dans un tel endroit pourrait provoquer un incendie ou une explosion. De tels environnements peuvent comprendre: des endroits où l'on utilise de l'oxygène médical sans ventilation adéquate; des gaz industriels (dissolvants de nettoyage, des vapeurs d'essence, etc.); une fuite de gaz naturel, etc.

- Ne placez que le combiné de votre téléphone près de votre oreille lorsqu'en mode de conversation.
- Ces adaptateurs ont été conçus pour être orientés en position verticale ou montés au sol. Les brochures ne sont pas conçues pour maintenir l'adaptateur en place si celui-ci est branché dans une prise au plafond ou sous une table/ armoire.
- Pour le MATERIEL RACCORDE PAR PRISE DE COURANT, le socle de prise de courant doit être installé à proximité du matériel et doit être aisément accessible.

-  **MISE EN GARDE:** Il peut y avoir un risque d'explosion si vous utilisez le mauvais type de piles pour le téléphone. N'utilisez que les piles rechargeables incluses ou les piles de rechange (BT205662). N'incinerez pas les piles. Celles-ci risqueraient d'exploser. Mettre au rebut les batteries usagées conformément aux instructions du fabricant. Débrancher les lignes téléphoniques avant le remplacement des piles.
 - Évitez d'utiliser la batterie dans les conditions suivantes:
 - des températures extrêmes faibles ou élevées auxquelles une batterie peut être soumise pendant l'utilisation, le stockage ou le transport.
 - remplacement d'une batterie par un type incorrect pouvant supprimer une protection.
 - mise au rebut d'une batterie dans un feu ou dans un four chaud, ou écrasement mécanique ou coupure d'une batterie, susceptible de provoquer une explosion.
 - maintien d'une batterie dans un environnement à très haute température pouvant provoquer une explosion ou la fuite de liquide ou de gaz

inflammables.

- batterie soumise à une pression de l'air extrêmement faible pouvant provoquer une explosion ou la fuite de liquide ou de gaz inflammables.
- N'utilisez que les adaptateurs inclus avec ce produit. L'utilisation d'un adaptateur dont la polarité ou la tension serait inadéquate risque d'endommager sérieusement le produit et mettre votre sécurité en péril.
 - La plaque signalétique appliquée est située au bas ou à proximité du produit.

CONSERVEZ CES INSTRUCTIONS

- Pile**
- N'utilisez que la pile incluse ou l'équivalent. Pour commander une pile de recharge, visitez notre site Web au www.vtechphones.com ou composez le 1-800-595-9511. Au Canada, visitez le phones.vtechcanada.com ou composez le 1-800-267-7377.
 - Ne jetez pas la pile au feu. Vérifiez les instructions spécifiques de mise aux rebus auprès des autorités locales.
 - N'ouvrez pas et ne mutilez pas la pile. L'électrolyte qui s'en échapperait est corrosif et pourrait causer des brûlures ou des blessures aux yeux ou à la peau. L'électrolyte est toxique si avalé.
 - Soyez prudents lorsque vous manipulez les piles afin d'éviter les courts-circuits provoqués par des matériaux conducteurs.
 - Rechargez la pile incluse avec cet appareil, selon les instructions et limites spécifiées dans ce guide d'utilisation.

Stimulateurs cardiaques implantés dans l'organisme

Les stimulateurs cardiaques (s'applique uniquement aux téléphones numériques sans fil) : L'organisme Wireless Technology Research, LLC (WTR), une firme de recherche indépendante, a mené une évaluation pluridisciplinaire des interférences entre les téléphones sans fil portatifs et les stimulateurs cardiaques implantés dans l'organisme. Appuyée par l'Administration des aliments et drogues (FDA) des États-Unis, la firme WTR recommande aux médecins :

Avis aux détenteurs de stimulateurs cardiaques

- Ils doivent tenir le téléphone sans fil à une distance d'au moins six pouces du stimulateur cardiaque.
- Ils ne doivent PAS placer le téléphone sans fil directement sur le stimulateur cardiaque, tel que dans une poche de chemise, lorsque celui-ci est en marche.
- Ils doivent utiliser le téléphone sans fil en l'appuyant sur l'oreille qui se trouve dans la direction opposée au

stimulateur cardiaque.

L'étude effectuée par l'organisme WRS n'a pas identifié de risque pour les détenteurs de stimulateurs cardiaques causés par les gens qui utilisent un téléphone sans fil à proximité de ceux-ci.

À propos des téléphones sans fil

Confidentialité : Les mêmes caractéristiques qui constituent des avantages pour les téléphones sans fil affichent également des restrictions. Les appels téléphoniques sont transmis entre le combiné sans fil et le socle par le biais d'ondes radio; il y a donc la possibilité que vos conversations téléphoniques sans fil soient interceptées par des équipements de réception radio se trouvant dans la portée du combiné sans fil. Pour cette raison, vous ne devez pas percevoir les communications téléphoniques sans fil comme étant aussi confidentielles que celles des téléphones à cordons.

Alimentation électrique : Le socle de ce téléphone sans fil doit être branché à une prise électrique fonctionnelle. La prise électrique ne doit pas être contrôlée par un interrupteur mural. Les appels ne pourront pas être effectués du combiné sans fil si le socle est débranché ou mis hors tension ou si le courant est coupé.

Possibilité d'interférences aux téléviseurs : Certains téléphones sans fil fonctionnent sur des fréquences pouvant causer des interférences aux téléviseurs et aux magnétoscopes. Pour réduire ou prévenir de telles interférences, ne placez pas le socle du téléphone sans fil près ou sur un téléviseur ou magnétoscope. S'il y a présence de parasites, il est conseillé d'éloigner le téléphone sans fil du téléviseur ou du magnétoscope afin de réduire possiblement les interférences.

Piles rechargeables : Manipulez les piles avec soin afin de ne pas les court-circuiter avec des bagues, bracelets ou clés. Les piles ou le conducteur peut surchauffer et causer des blessures. Respectez la polarité adéquate entre la pile et le chargeur.

Les bloc-piles rechargeables à l'hydrure métallique de nickel : Jetez ces blocs-piles de manière écologique et sécuritaire. Ne les incinerez pas et ne les percez pas. Tel que les autres piles de ce type, elles pourraient dégager une matière toxique qui peut causer des blessures corporelles si elles sont brûlées ou percées.

The RBRC seal



The RBRC seal on the nickel-metal hydride battery indicates that VTech Communications, Inc. is voluntarily participating in an industry program to collect and recycle these batteries at the end of their useful lives, when taken out of service within the United States and

Canada.

The program provides a convenient alternative to placing used nickel-metal hydride batteries into the trash or municipal waste, which may be illegal in your area. VTech's participation makes it easy for you to drop off the spent battery at local retailers participating in the program or at authorized VTech product service centers. Please call **1 (800) 8 BATTERY®** for information on Ni-MH battery recycling and disposal bans/restrictions in your area. VTech's involvement in this program is part of its commitment to protecting our environment and conserving natural resources. The RBRC seal and 1 (800) 8 BATTERY® are registered trademarks of Call2recycle, Inc.

FCC, ACTA and IC regulations

FCC Part 15

NOTE: This equipment has been tested and found to comply with the requirements for a Class B digital device under Part 15 of the Federal Communications Commission (FCC) rules. These requirements are intended to provide reasonable protection against harmful interference in a residential installation. This equipment generates, uses and can radiate radio frequency energy and, if not installed and used in accordance with the instructions, may cause harmful interference to radio communications. However, there is no guarantee that interference will not occur in a particular installation. If this equipment does cause harmful interference to radio or television reception, which can be determined by turning the equipment off and on, the user is encouraged to try to correct the interference by one or more of the following measures:

- Reorient or relocate the receiving antenna.
- Increase the separation between the equipment and receiver.
- Connect the equipment into an outlet on a circuit different from that to which the receiver is connected.
- Consult the dealer or an experienced radio/TV technician for help.

WARNING: Changes or modifications to this equipment not expressly approved by the party responsible for compliance could void the user's authority to operate the equipment.

This device complies with Part 15 of the FCC rules. Operation is subject to the following two conditions: (1) this device may not cause harmful interference, and (2) this device must accept any interference received, including interference that may cause undesired operation. Privacy of communications may not be ensured when using this

telephone.

To ensure safety of users, the FCC/ISED has established criteria for the amount of radio frequency energy that can be safely absorbed by a user or bystander according to the intended usage of the product. This product has been tested and found to comply with the FCC/ISED criteria. The handset may be safely held against the ear of the user. The telephone base shall be installed and used such that parts of the user's body other than the hands are maintained at a distance of approximately 20 cm (8 inches) or more. This Class B digital apparatus complies with Canadian requirement: CAN ICES-3 (B)/NMB-3(B).

FCC Part 68 and ACTA

This equipment complies with Part 68 of the FCC rules and with technical requirements adopted by the Administrative Council for Terminal Attachments (ACTA). The label on the back or bottom of this equipment contains, among other things, a product identifier in the format US:AAAEQ##TXXXX. This identifier must be provided to your telephone service provider upon request.

The plug and jack used to connect this equipment to premises wiring and the telephone network must comply with applicable Part 68 rules and technical requirements adopted by ACTA. A compliant telephone cord and modular plug is provided with this product. It is designed to be connected to a compatible modular jack that is also compliant. An RJ11 jack should normally be used for connecting to a single line and an RJ14 jack for two lines. See the installation instructions in the user's manual.

The Ringer Equivalence Number (REN) is used to determine how many devices you may connect to your telephone line and still have them ring when you are called. The REN for this product is encoded as the 6th and 7th characters following the US: in the product identifier (e.g., if ## is 03, the REN is 0.3). In most, but not all areas, the sum of all RENs should be five (5.0) or less.

For more information, please contact your telephone service provider. This equipment must not be used with Party Lines. If you have specially wired alarm dialing equipment connected to your telephone line, ensure the connection of this equipment does not disable your alarm equipment. If you have questions about what will disable alarm equipment, consult your telephone service provider or a qualified installer.

If this equipment is malfunctioning, it must be unplugged from the modular jack until the problem has been corrected. Replacement to this telephone equipment can only be made by the manufacturer or its

authorized agents. For replacement procedures, follow the instructions outlined under the **Limited warranty**. If this equipment is causing harm to the telephone network, the telephone service provider may temporarily discontinue your telephone service. The telephone service provider is required to notify you before interrupting service. If advance notice is not practical, you will be notified as soon as possible. You will be given the opportunity to correct the problem and the telephone service provider is required to inform you of your right to file a complaint with the FCC. Your telephone service provider may make changes in its facilities, equipment, operation, or procedures that could affect the proper functioning of this product. The telephone service provider is required to notify you if such changes are planned.

If this product is equipped with a corded or cordless handset, it is hearing aid compatible. If this product has memory dialing locations, you may choose to store emergency telephone numbers (e.g., police, fire, medical) in these locations. If you do store or test emergency numbers, please: Remain on the line and briefly explain the reason for the call before hanging up. Perform such activities in off-peak hours, such as early morning or late evening.

Industry Canada

This device contains licence-exempt transmitter(s)/ receiver(s) that comply with Innovation, Science and Economic Development Canada's licence-exempt RSS(s). Operation is subject to the following two conditions: (1) This device may not cause harmful interference. (2) This device must accept any interference, including interference that may cause undesired operation of the device.

Privacy of communications may not be ensured when using this telephone. The term "IC:" before the certification/registration number only signifies that the Industry Canada technical specifications were met.

The Ringer Equivalence Number (REN) for this terminal equipment is 0.1. The REN indicates the maximum number of devices allowed to be connected to a telephone interface. The termination of an interface may consist of any combination of devices subject only to the requirement that the sum of the RENs of all the devices not exceed five.

This product meets the applicable Innovation, Science and Economic Development Canada technical specifications.

Table of contents

What's in the box **1**

Connect and install **2**

Connect the telephone base.....	2
Install the battery.....	3
Connect the charger.....	4
Charge the battery.....	4
Line power mode (no AC power).....	5
Mount the telephone base (optional).....	6

Setup **8**

Date and time.....	8
Voice guide to set Smart call blocker.....	10
Voice guide to set answering system.....	12
SOS emergency call.....	13
Photo speed dial.....	19
LCD language.....	23
Talking digits.....	24
Key tone.....	25
Caller ID announce on/off.....	26

Use caller ID to automatically set date and time.....	27
Voicemail number.....	28
Clear voicemail indicator.....	29
Dial mode.....	30
Alarm reminder and melody.....	31

Operate **34**

Display.....	34
Make a call.....	35
Answer a call.....	35
End a call.....	36
Speakerphone.....	37
Volume.....	37
Make SOS emergency call.....	38
Temporary ringer silencing.....	39
Call waiting.....	39
Redial.....	40
Photo/memory speed dial.....	40
Temporary tone dialing.....	41
Audio Assist®.....	41
Equalizer.....	42

Find handset.....	42
Join a call in progress.....	43
Intercom.....	44
Call transfer using Intercom.....	46

Bluetooth® **48**

Turn on Bluetooth feature.....	48
Turn off Bluetooth feature.....	49
Pair and connect a Bluetooth headset.....	50
Make a call with Bluetooth headset.....	52
Answer a call with Bluetooth headset.....	52
End a call with Bluetooth headset.....	52
Switch between cordless handset and Bluetooth headset.....	53
Bluetooth headset name.....	54
Remove Bluetooth headset.....	54
Set auto connection / manual connection.....	55

Phonebook **56**

Add a phonebook entry.....	56
Review phonebook entry.....	58

Dial a phonebook entry.....	59
Delete a phonebook entry.....	59
Save a redial entry to the phonebook.....	60
Edit a phonebook entry.....	61

Caller ID **62**

Review caller ID log entry.....	62
Save a caller ID log entry to the phonebook.....	63
Dial a caller ID log entry.....	64
Delete a caller ID log entry.....	64

Smart call blocker* **65**

Call categories.....	66
Set Smart call blocker on/off.....	68
Set welcome calls.....	69
Set unwelcome calls.....	73
Control calls without numbers.....	75
Control uncategorized calls.....	76
Screen calls without numbers.....	77
Screen uncategorized calls.....	78

Add a screened number to the allow list or block list.....79

Option while on a call.....79

Answering system.....80

About the built-in answering system and voicemail service.....80

Built-in answering system VS Voicemail service.....80

Turn the built-in answering system on or off.....82

Set number of rings.....82

Message playback.....84

Skip a message.....85

Repeat the playing message.....85

Play the previous message.....86

Delete a message.....86

Delete all messages.....87

Remote access.....88

Set remote access code.....89

Additional devices.....90

Add and register expansion handset....90

Add and register photo speed dial handset.....91

Device setup.....92

Audio doorbell.....94

Test device signal strength.....106

Device monitoring.....108

Need help?.....109

Limited warranty.....110



What's in the box

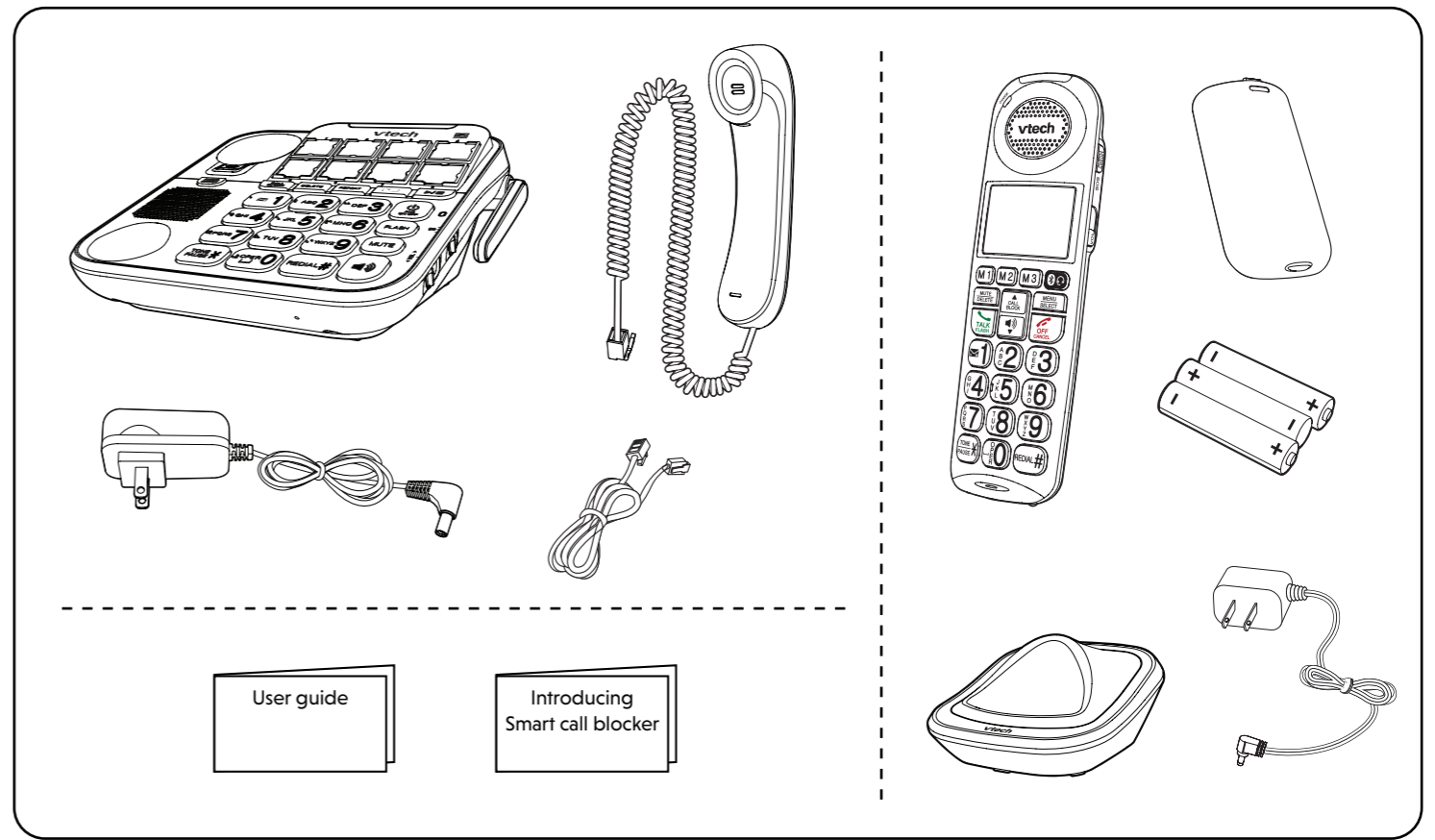



Connect and install

Connect the telephone base

If you subscribe to digital subscriber line (DSL) high-speed Internet service through your telephone line, make sure you connect a DSL filter (not included) to the telephone wall jack.

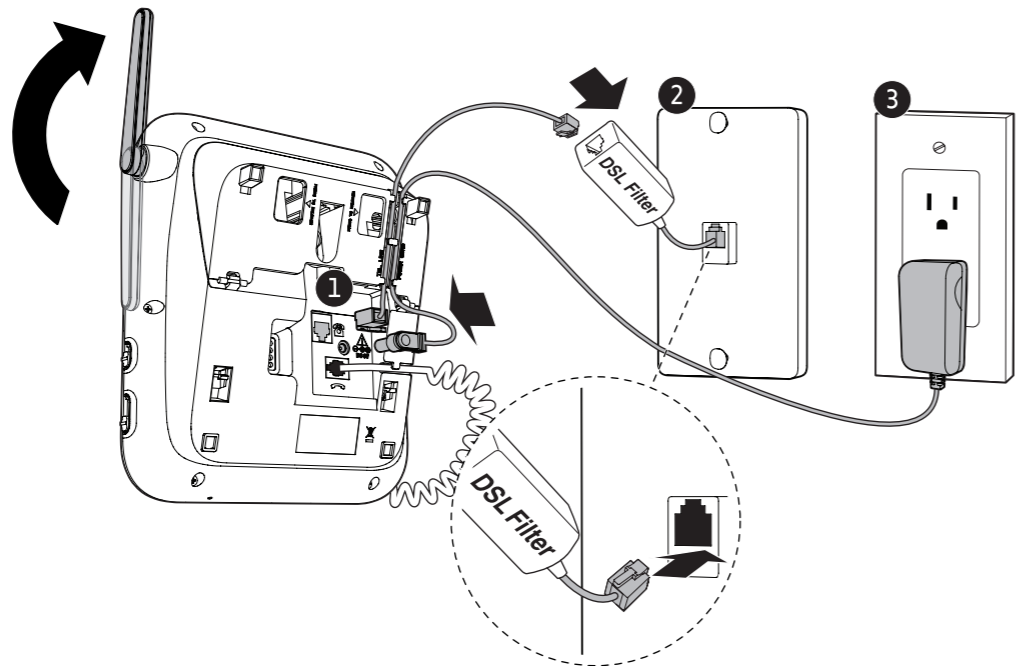

2

Install the battery

1

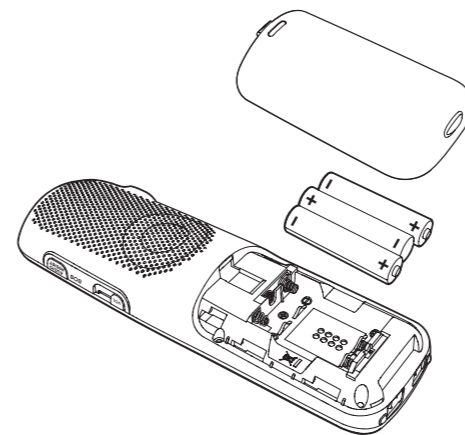

2

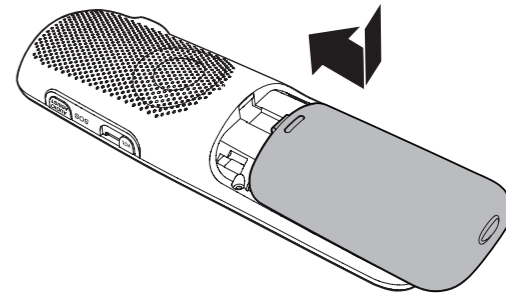

⚠ CAUTIONS

- Use only the rechargeable batteries provided or replacement batteries (model BT205662).
- Do not use other alkaline, manganese or Ni-Cd batteries, nor other non-rechargeable batteries for operating the cordless handset. They may cause failure or malfunction of the handset or the telephone system.

📄 NOTES

- Charge the batteries provided with this product only in accordance with the instructions and limitations specified in this quick start guide.
- If the handset will not be used for a long time, disconnect and remove the batteries to prevent possible leakage.

3



Connect and install

Connect the charger

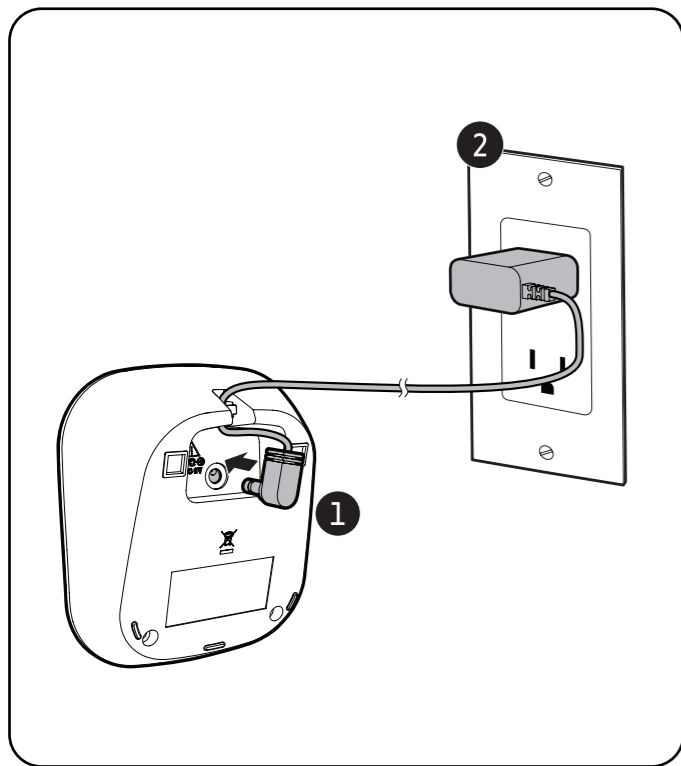

Charge the battery

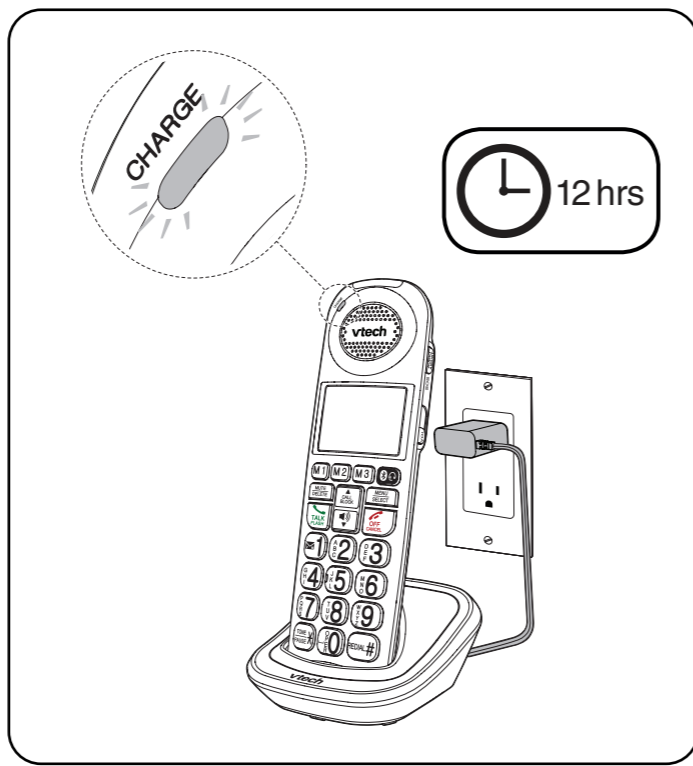

Line power mode (no AC power)

When there is a power failure, the telephone base uses power from the telephone line to let you make and answer calls using the corded handset and dialing keys.

To make a call during power failure:



Lift the corded handset and wait for a dial tone.



Dial a telephone number using the dialing keys. Wait to hear each key tone upon inputting a digit before pressing the next dialing key.

To answer a call during power failure:



Lift the corded handset.



Connect and install

Mount the telephone base (optional)

1

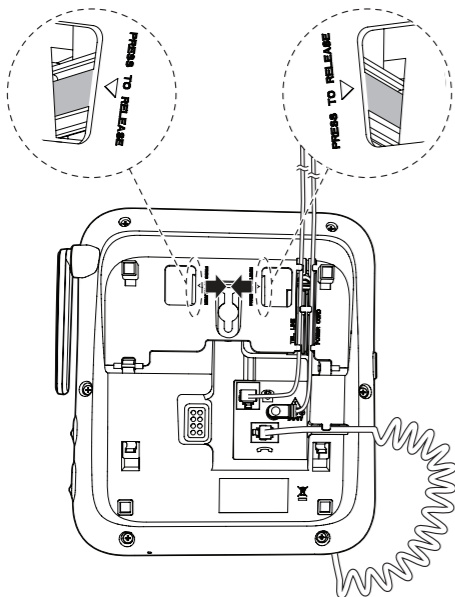

Press the tabs of the wall-mount bracket to release it from the tabletop orientation.

2

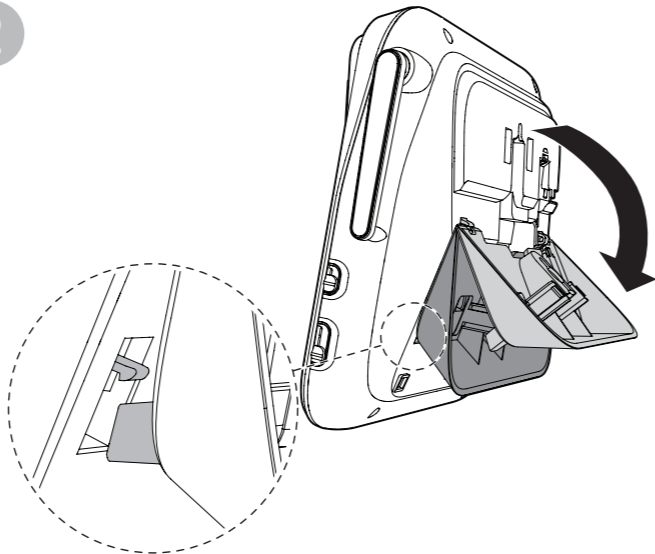

Rotate the wall-mount bracket down and push it into the telephone base until it clicks into place.

3

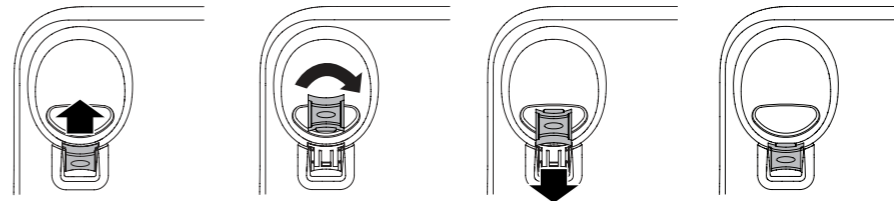

Slide the handset tab upward.

Rotate it upside down.

Slide the handset tab back into the slot.

The protruding edge of the handset tab holds the corded handset in place when the telephone is mounted on the wall.

4

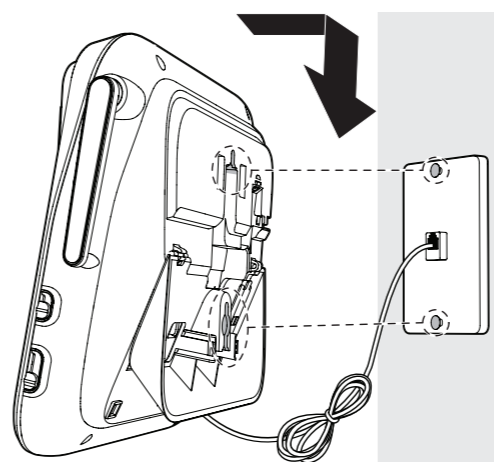

5

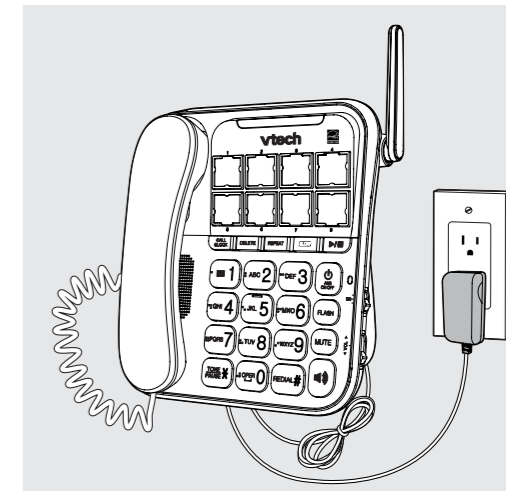



Setup

Date and time

After you install your telephone or power returns following a power outage and battery depletion, the handset will prompt you to set the date and time, and to configure the Smart call blocker and answering system through the voice guides.

Follow the steps below to set the date and time. For example, if the date is 31 December, 2023, and the time is 10:59 PM:

When the handset prompts you to set the date and time...

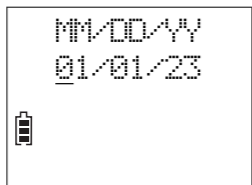

Enter the month (**MM**), day (**DD**), and year (**YY**).

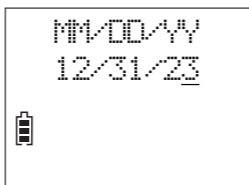

Press **SELECT**.

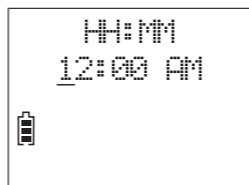

Enter the hour (**HH**) and minute (**MM**).

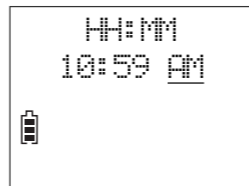

Press any number key to toggle between **AM** and **PM**.

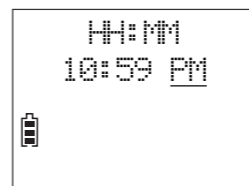

Press **SELECT** to save.

NOTE

Make sure you set the date and time including the year correctly; otherwise the answering system does not announce the correct day of the week for your recorded messages time stamp.

TIP If you subscribe to caller ID service, the day, month and time are set automatically with each incoming call.

- OR -

When the handset is not in use:

1. Press **MENU**.
2. Press ▼ or ▲ to scroll to **Set date/time**.
3. Press **SELECT**, and then follow the **Date and time** steps to set the date and time.





Voice guide to set Smart call blocker

After the date and time setting is done or skipped, the cordless handset then prompts if you want to set Smart call blocker. For more details on **Smart call blocker**, see page 65.

You can follow the voice guide to set your telephone system to allow or to screen all incoming calls, or to screen calls that do not display a phone number.

When the handset prompts you to set Smart call blocker via voice guide...

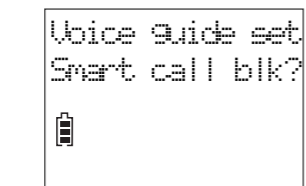

"Hello! This voice guide will assist you with the basic setup of Smart call blocker..."

1



Press **SELECT**.

2



Listen to the instructions and then choose one of the options.

On the cordless handset:



Press **1** if you want to screen calls with telephone numbers that are not saved in your Phonebook, Allow list or Star name list;



Press **2** if you only want to screen calls that do not display a phone number; or



Press **3** if you do not want to screen calls, and want to allow all incoming calls to get through.

NOTE

- If you select option **1** to screen calls, we recommend that you add the phone numbers of your family members and friends, and desired businesses to your **Phonebook** (see page 56) or **Allow list** (see page 69), or add their names to the **Star name list** (see page 70). This will avoid Smart call blocker to screen their calls.

TIP

- Read the **Introducing Smart call blocker** leaflet provided in your package to learn how to set up your Smart call blocker.



Voice guide to set answering system

After the Smart call blocker setting is done or skipped, the handset will then prompt if you want to set up the answering system.

This feature assists you to do the basic setup of the answering system. You can follow the voice guide to record your own announcement, set the number of rings and the message alert tone.

When the handset prompts you to set up the answering system via voice guide...

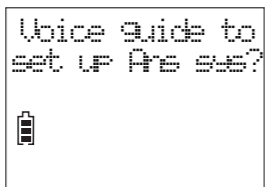

1



Press **SELECT**.



"This voice guide will assist you with the basic setup of your answering system."

2



Set up your answering system by inputting the designated numbers as instructed in the voice guide.

SOS emergency call

The **AUDIO ASSIST/SOS** button on the cordless handset can function as SOS emergency button. It lets you quickly page other system devices and call the preset external numbers for help in an emergency.

You can preset up to five SOS numbers.

If you have purchased and registered a Wearable home SOS pendant (**SN7022**) to your telephone system, the SOS pendant will function as same as the SOS emergency button of the cordless handset.

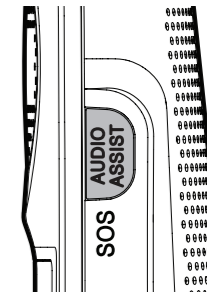

CAUTIONS

- To ensure proper operation, the telephone system must be installed according to the installation instructions on page 2 to page 4. To verify that the telephone system is operating properly and can successfully make emergency calls to the preset numbers, the telephone system must be tested immediately after installation, and periodically thereafter, according to the setup instructions on page 15 to page 18, and the operations on page 38.
- The telephone system cannot make an emergency call when other equipment (telephone, answering system, computer modem, etc.) connected to the same phone line is in use.
- Do not solely rely on the SOS button on the cordless handset, or the Wearable home SOS pendant (**SN7022**, purchased separately), for getting help in case of emergency. The functionality of the SOS emergency call is dependent on the phone settings and network availability.

NOTE

- We recommend you set all five SOS numbers to maximize the possibility of receiving response from others when you make an emergency call.



Setup

How does SOS emergency call work?

- To make an emergency call, press and hold **AUDIO ASSIST/SOS** on the right side of the cordless handset for three seconds. The telephone base announces "*Emergency mode is activated*". The handset then pages all system devices. All devices ring an alert tone and the handset screen shows **SOS mode** for 20 seconds. After that, the telephone then calls the preset SOS numbers in sequence until the call is answered.
 - The telephone enables internal SOS alert by default. When this feature is enabled, the telephone pages all system devices before calling the preset SOS numbers.
 - If you disable internal SOS alert (see page 16), the telephone calls the preset SOS numbers directly when you press and hold **AUDIO ASSIST/SOS** on the cordless handset.
- When the SOS call to the preset external number is answered, the call receiver hears an SOS message. You can record your own message or use the default message (see page 17).
- The SOS message played by the telephone asks the SOS call receiver to respond by pressing a number key. After the call receiver presses a number key, you can then talk to the call receiver with your cordless handset.
- When the SOS emergency call is answered by answering machine or voicemail, the call will be terminated after 60 seconds. The telephone then dials the next SOS number in sequence.
- When none of the preset SOS numbers answer, the telephone re-calls the preset SOS numbers in sequence until the call is answered. The telephone will call all the preset SOS numbers for 3 times before aborting the operation when none of the calls are answered.

Set SOS emergency numbers

1 Press **MENU SELECT**.

2 Press **MENU SELECT**.

3 Press **MENU SELECT**.

4 Scroll to select **SOS 1**, **SOS 2**, **SOS 3**, **SOS 4**, or **SOS 5**, and then press **SELECT**.

5 Press **MENU SELECT** again to add an emergency number.

6 Enter the number. Then, press **SELECT**.

7 Enter the name. Then, press **SELECT**.



Setup

Enable or disable internal SOS alert

Internal SOS alert is enabled by default.

When you press and hold **AUDIO ASSIST/SOS** to make an emergency call, the telephone pages all registered system devices for 20 seconds. After that, the telephone then calls the five preset SOS numbers in sequence, until the call is answered.

You can disable this setting to allow you to make emergency calls directly to the preset SOS numbers.

1 Press **MENU** on the handset when it is not in use.

2 Scroll to **Set SOS**, and then press **SELECT**.

3 Press to select **Call internal**.

4 Scroll to select **Enable** or **Disable**, and then press **SELECT**.

Record SOS message

When you make an emergency call with the **AUDIO ASSIST/SOS** button on the cordless handset, the SOS message is played to the call receiver after he/she picks up. The default SOS message is "This is an emergency call. Please press any number key to start the conversation." You can record your own message using the cordless handset.

1 Press **MENU** on the handset when it is not in use.

2 Scroll to **Set SOS**, and then press **SELECT**.

3 Scroll to **SOS message**, and then press **SELECT**.

4 Press **SELECT** to select **Record anc.**

5 Speak toward the cordless handset to record your message. Press **5** when done.

"Record after the tone. Press STOP when you are done."

NOTE Make sure your recorded SOS message includes your name, your SOS message, and a request to the far-end caller on pressing any number key to start a conversation.



Play or reset SOS message

1 **MENU SELECT** Press **MENU** on the handset when it is not in use.

2 **MENU SELECT**

Scroll to **Set SOS**, and then press **SELECT**.

3 **MENU SELECT**

Scroll to **SOS message**, and then press **SELECT**.

4 **MENU SELECT**

Scroll to select **Play ann** or **Reset ann**, and then press **SELECT**. If you select **Reset ann**, press **SELECT** twice.

Photo speed dial

There are eight photo speed dial memory keys **1** to **8** on the telephone base, and three direct memory keys **M1** to **M3** on the cordless handset.

You can store the telephone numbers you wish to quick dial to the photo speed dial keys. When you set the first three photo speed dial keys **1**, **2** and **3** on the telephone base, the same numbers will also automatically set in the **M1**, **M2** and **M3** keys on the cordless handset.

* TIP

- We recommend you store at least two contacts that you may need to call them more often or immediately to photo speed dial keys **1** and **2** on the telephone base.

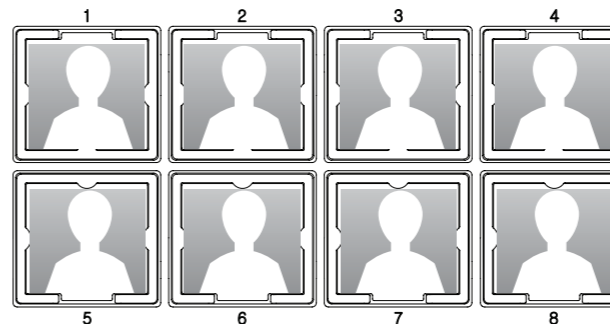



Photo speed dial

Store a photo speed dial entry:

①   Press **MENU** when the handset is not in use.



②   Scroll to **Direct memory**, and then press **SELECT**.

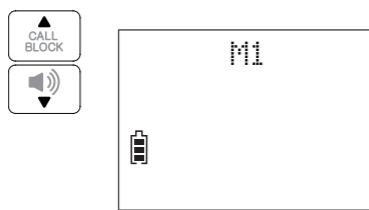

③   Scroll to select **M1, M2, M3, M4, M5, M6, M7** or **M8**, and then press **SELECT**.

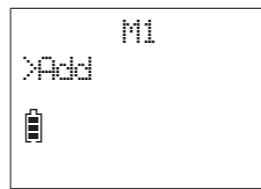

④   Press **SELECT** again to add the speed dial number.



⑤    Enter the phone number, and then press **SELECT**.

Enter the phone number, and then press **SELECT**.



⑥    Enter the name, and then press **SELECT** to save.

Enter the name, and then press **SELECT** to save.

NOTE

- To store another photo speed dial entry, repeat the steps.



Photo speed dial

Insert photos for speed dial keys:

You can insert photos into the photo speed dial compartments, or write the contact names on cards and insert them into the compartments.

NOTE

The telephone base is shipped with protective stickers covering the photo speed dial compartments. Remove the protective sticker before use.

1. Remove the photo speed dial compartment cover.
2. Crop your desired photo into the size specified on the right, and then insert it into the photo speed dial compartment. Then, insert the photo speed dial compartment cover back to the compartment.

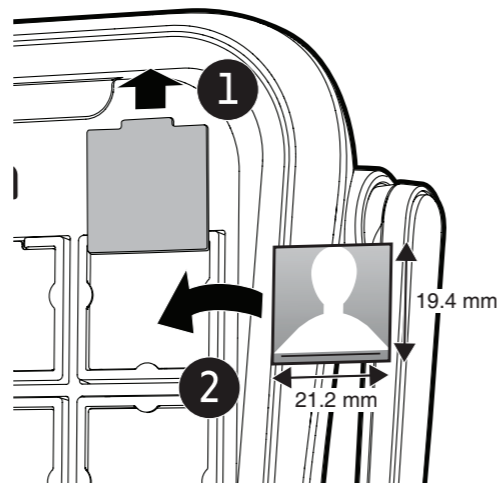

LCD language

You can select your handset's display language (English, French or Spanish).

1



MENU
SELECT

Press **MENU** when the handset is not in use.



Set date/time
 XSettings
 [Battery icon]

2



MENU
SELECT

Scroll to **Settings**, and then press **SELECT**.

3



MENU
SELECT

Press **SELECT** to select **LCD language**.



LCD LANGUAGE
 XEnglish
 [Battery icon]

4



MENU
SELECT

Scroll to highlight **English, Français** or **Español**, and then press **SELECT**.

5



MENU
SELECT

Press **SELECT** to confirm.



Setup

Talking digits

You can choose whether the digits are to be announced whenever you press the number keys.

1 Press **MENU** when the handset is not in use.

2 Scroll to **Talking digits**, and then press **SELECT**.

3 Scroll to select **On** or **Off**, and then press **SELECT**.

Key tone

The cordless handset is set to beep with each key press. You can adjust the key tone volume or turn it off. If you turn off the key tone, there are no beeps when you press keys.

1 Press **MENU** when the handset is not in use.

2 Scroll to **Settings**, and then press **SELECT**.

3 Scroll to **Key tone**, and then press **SELECT**.

4 Scroll to select the desired volume or select **Off**.

5 Press **SELECT** to confirm.



Setup

Caller ID announce on/off

The caller ID announce feature lets you know who's calling without having to look at the display. When you have an incoming call, the handset and/or base speaks "Call from..." and the name of the caller based on the phonebook or caller ID information. The default setting is **On**.

NOTE

- To use the caller ID announce feature, you must subscribe to caller ID service from your **telephone service provider**.

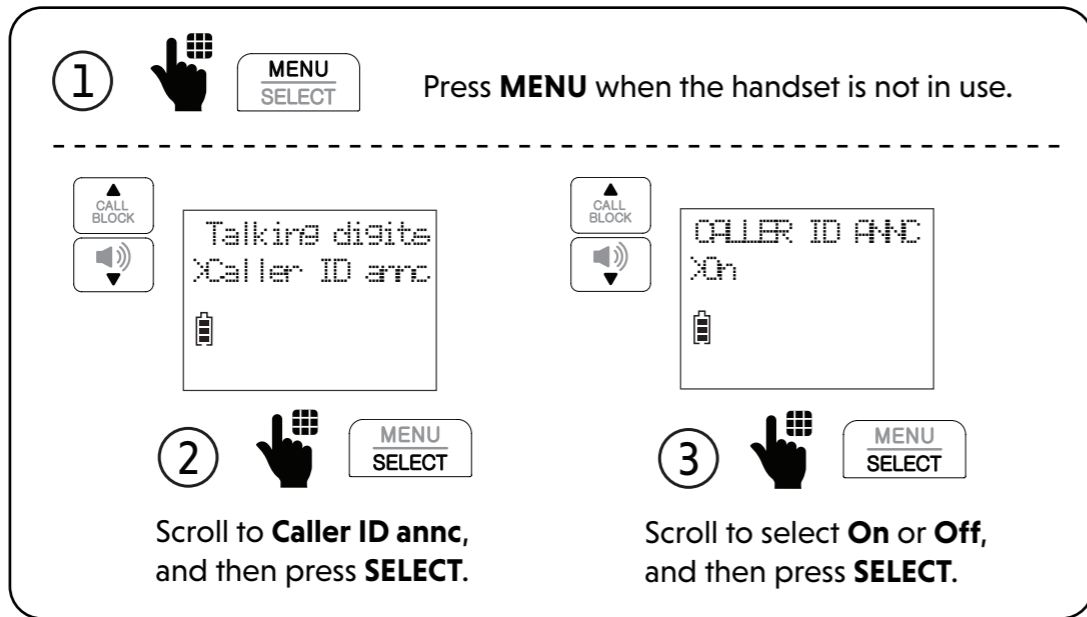

Use caller ID to automatically set date and time

If you subscribe to caller ID service, you can choose to set the date and time for each incoming call by the caller ID information automatically. The default setting is **On**.

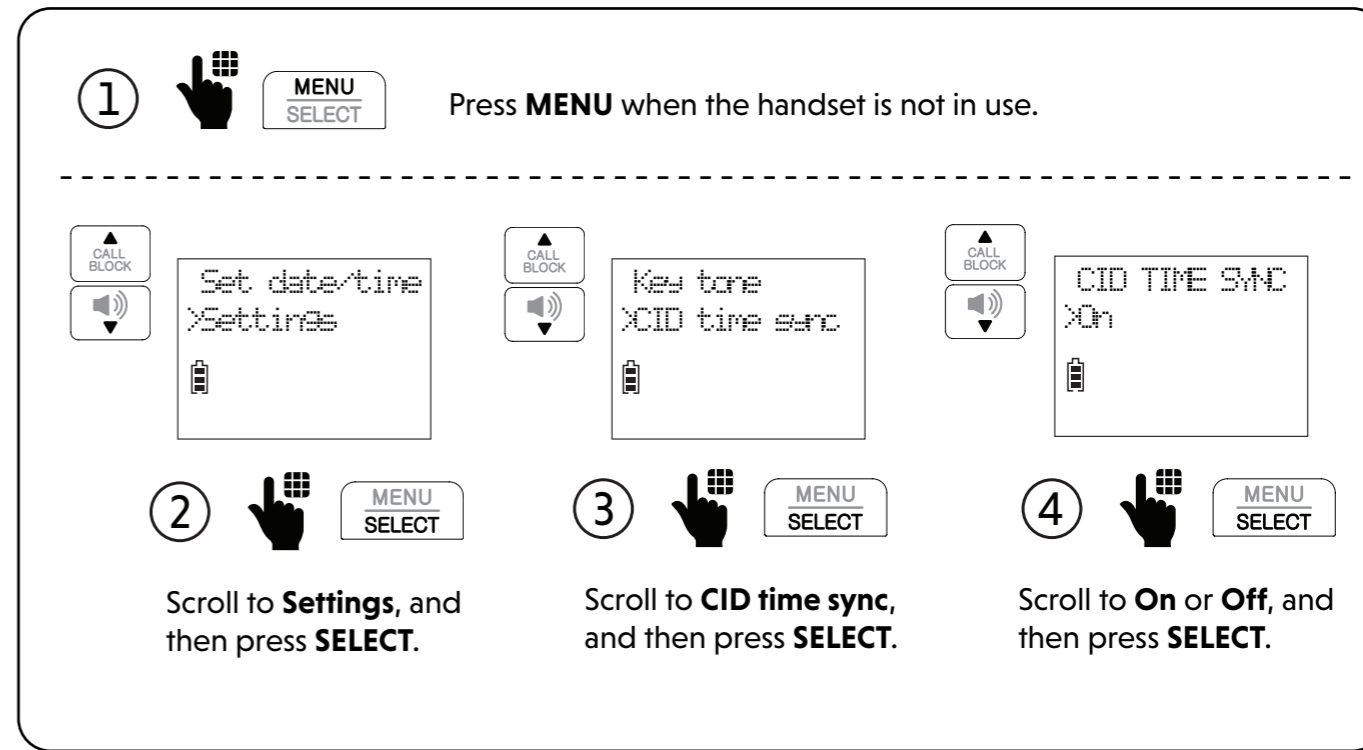



Setup

Voicemail number

If you subscribe to a voicemail service offered by your **telephone service provider**, you can save your voicemail number to  for quick access.

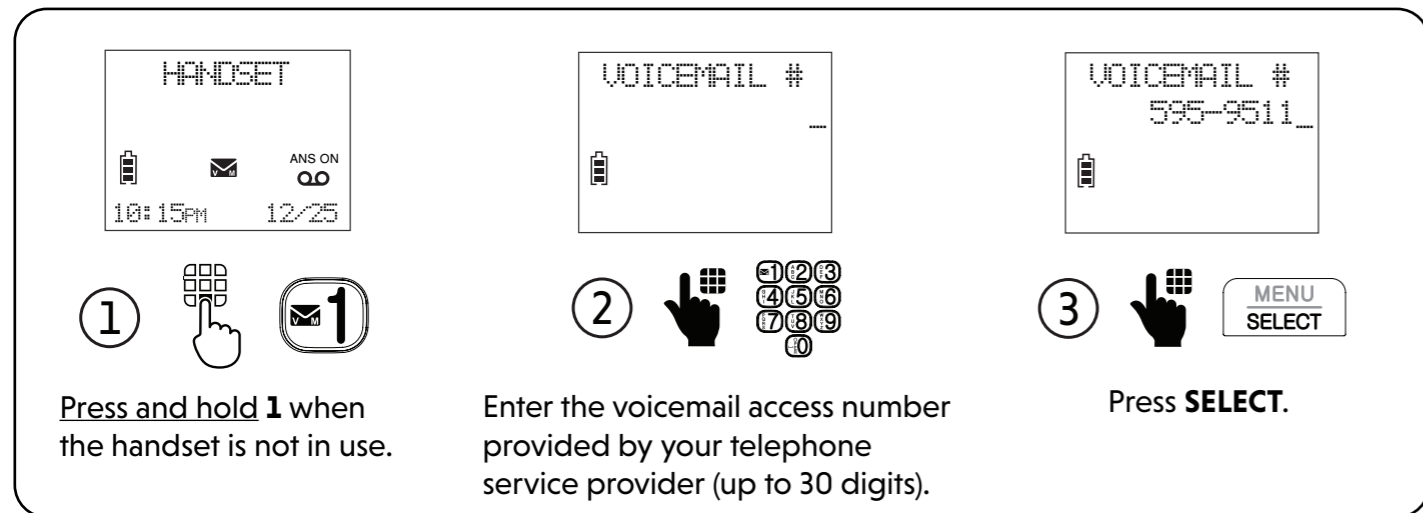

1 Press and hold **1** when the handset is not in use.

2 Enter the voicemail access number provided by your telephone service provider (up to 30 digits).

3 Press **SELECT**.

To retrieve voicemails from your telephone service provider:



Press and hold **1**.

Clear voicemail indicator

Use this feature when the telephone indicates that there is new voicemail but there are none. This feature only turns off the indicators, **New voicemail** and . It does not delete your voicemail messages. As long as you have new voicemail messages, your telephone service provider continues to send the signal to turn on the indicators.

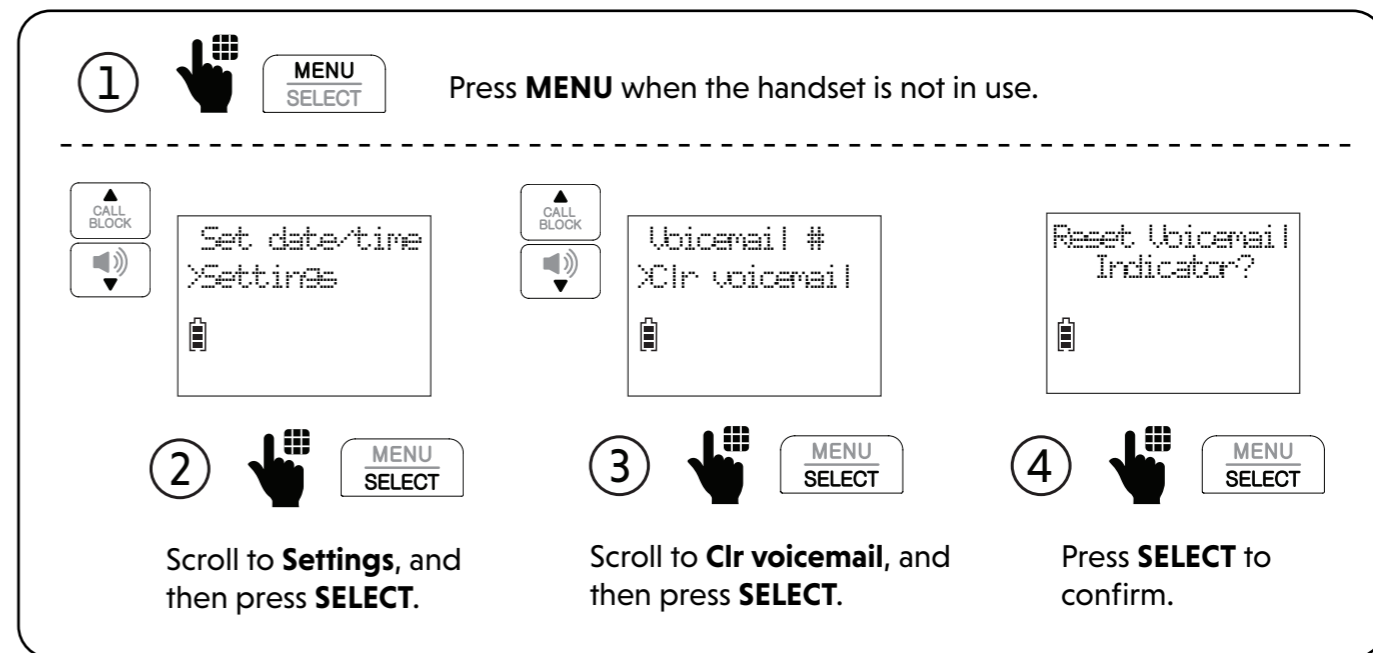

1 Press **MENU** when the handset is not in use.

2 Scroll to **Settings**, and then press **SELECT**.

3 Scroll to **Clr voicemail**, and then press **SELECT**.

4 Press **SELECT** to confirm.



Setup

Dial mode

The dial mode is preset to touch-tone dialing. If you have pulse (rotary) service, you need to change the dial mode to pulse dialing before using the telephone.

1 Press **MENU** when the handset is not in use.

<p>Set date/time >Settings</p>	<p>Home area code >Dial mode</p>	<p>DIAL MODE >Touch-tone</p>
<p>2 </p>	<p>3 </p>	<p>4 </p>
<p>Scroll to Settings, and then press SELECT.</p>	<p>Scroll to Dial mode, and then press SELECT.</p>	<p>Scroll to select Touch-tone or Pulse, and then press SELECT.</p>

Alarm reminder and melody

You can set alarm reminders that remind you at specific times, once, daily, or at weekdays or weekends.

1 Press **MENU** when the handset is not in use.

<p>Set S/S >Reminder</p>	<p>REMINDER >Reminder 1</p>	<p>REMINDER 1 >On/Off</p>
<p>2 </p>	<p>3 </p>	<p>4 </p>
<p>Scroll to Reminder, and then press SELECT.</p>	<p>Scroll to select a reminder from Reminder 1 to Reminder 10, and then press SELECT.</p>	<p>Press SELECT to select On/Off.</p>



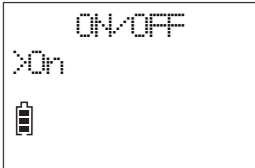

Alarm reminder and melody

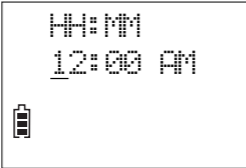

5  **MENU SELECT**

Scroll to **On** and then press **SELECT**.



6  

Enter the hour (**HH**) and minute (**MM**). Then, press any number key to change between **AM** and **PM**.

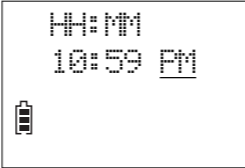

7  **MENU SELECT**

Press **SELECT**.

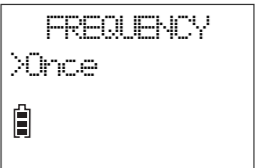

8  **MENU SELECT**

Scroll to select one of the frequency options, and then press **SELECT**.

- **Once;**
- **Daily;**
- **Mon. to Fri.;** or
- **Sat. to Sun.**

 **NOTES**

- When the set reminder alarm time is due, the alarm will not ring if the telephone is in use.
- The cordless handset rings for 30 seconds when the alarm time is due.
- Press any key on the handset to stop the alarm when ringing.

Alarm reminder and melody

You can also select the alarm reminder melody.

1  **MENU SELECT** Press **MENU** when the handset is not in use.

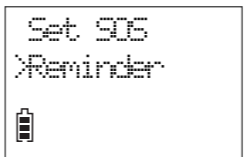

2  **MENU SELECT**

Scroll to **Reminder**, and then press **SELECT**.

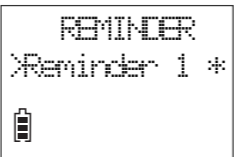

3  **MENU SELECT**

Scroll to select the desired reminder, and then press **SELECT**.



4  **MENU SELECT**

Scroll to **Melody**, and then press **SELECT**.

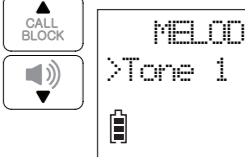

5  **MENU SELECT**

Scroll to the desired melody, and then press **SELECT**.

 **NOTE**

- A reminder you have previously set up is added with an asterisk (*) after the name, for example, **Reminder 1 ***.



Operate

Display

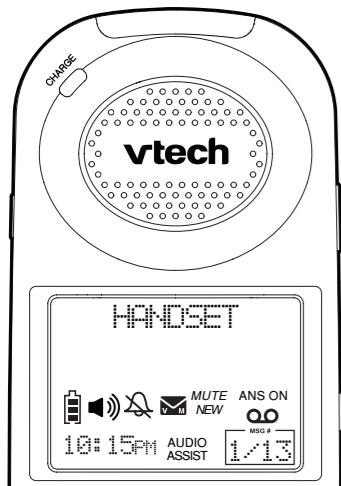

	The battery is low and needs charging.
	The battery is charging.
	The battery is fully charged.
	The handset speakerphone is in use.
	Handset ringer is off.
	New voicemail received from your telephone service provider .
<i>MUTE</i>	The handset microphone is muted.
<i>NEW</i>	There are new caller ID log entries.
<i>ANS ON</i>	Answering system is on.
	There are new messages in the answering system.
	Number of new/old messages recorded.
<i>AUDIO ASSIST</i>	The handset Audio Assist® feature is on.

Audio Assist® is a registered trademark of Advanced Amercian Telephones.

Make a call

① - OR -

On the cordless handset, press **TALK** or .

----- OR -----

- OR -

On the telephone base, press or lift the corded handset.

②

Dial the phone number.

Answer a call

On the cordless handset:

- OR - - OR -

Press **TALK**, or any dialing keys on the handset.

----- OR -----

On the telephone base:

- OR -

Press on the telephone base or lift the corded handset.



End a call

On the cordless handset:



Press **OFF** on the handset.
-OR-
Place the handset in the handset charger.

- OR -

On the telephone base:

If you are using the telephone base speakerphone or the corded handset:



Speakerphone

On the cordless handset:



----- OR -----

On the telephone base:

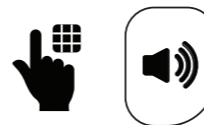

Volume

Handset

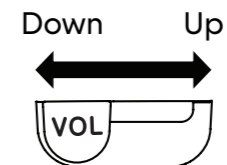

Telephone base



Slide the **VOL** control on the cordless handset or on the telephone base:

- to adjust the speaker volume level when on a call; or
- to adjust the ringer volume when the telephone is ringing.

⚠ CAUTION

- For hearing protection, do not put the cordless handset near your ear when the telephone is ringing. Loud ringer sound may damage your hearing. Adjust the volume to lower the ringer sound if you find it too loud.





Make SOS emergency call

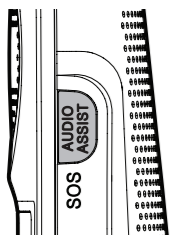

Press and hold **AUDIO ASSIST/SOS** on the cordless handset for 3 seconds. The telephone base announces, "Emergency mode is activated" and pages all registered devices. All devices ring an alert tone, and after 20 seconds, the telephone starts calling the preset SOS numbers.

- If you disable internal SOS alert (page 16), the telephone calls the preset SOS numbers in sequence directly when you press and hold **AUDIO ASSIST/SOS**. See page 13 for details.

----- OR -----



If you have purchased and registered a Wearable home SOS pendant (**SN7022**), press the dial key  on the SOS pendant to make SOS calls.

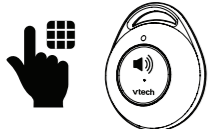

You can cancel SOS emergency call at any time:

- Press **TALK** or **CANCEL** on the handset; or
- Press and hold **AUDIO ASSIST/SOS** on the handset; or
- Press  on the telephone base; or
- Press the **CANCEL** key on the back of the SOS pendant.



"This is an emergency call. Please press any number key to start the conversation."

NOTES



- When the emergency call is answered, the telephone plays the SOS message (see page 17) to the call receiver, asking the receiver to respond by pressing a number key on his/her phone.
- After the call receiver presses a number key, you can then start a conversation with the call receiver.
- The **SOS AUDIO ASSIST** button on the cordless handset functions as Audio Assist button when on a call or listening to a message or announcement.

Temporary ringer silencing

When the telephone is ringing, you can temporarily silence the ringer without disconnecting the call. The next call rings normally at the preset volume.

When the telephone is ringing:

On the cordless handset:





- OR -





----- OR -----

On the telephone base:

Call waiting

When you subscribe to call waiting service from your **telephone service provider**, you hear an alert tone if there is an incoming call while you are already on a call.

When on a call using the cordless handset.

- OR -



When on a call using the corded handset on the telephone base.



- Press **FLASH** on the handset or telephone base to put the current call on hold and take the new call.
- Press **FLASH** at any time to switch back and forth between calls.



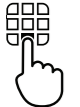

Operate

Redial

The last 10 numbers dialed (up to 30 digits) are stored in the cordless handset. The telephone base stores the last number dialed.

①   Press and hold **REDIAL**, and then press ▼ or ▲ to browse the redial entries when the handset is not in use.

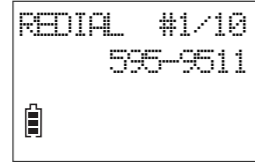
②    To redial, press **TALK** on the handset.

----- OR -----
To redial the last number using the telephone base, lift the corded handset on the telephone base and then press and hold REDIAL.

Photo/memory speed dial



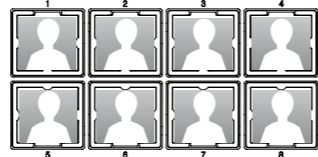

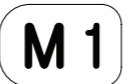
If you have set any of the eight direct memory speed dial numbers, you can press a photo speed dial key on the telephone base, or a directory memory key on the handset to quickly dial the preset number. The telephone base and the cordless handset share the first three direct memory speed dial numbers. For details on setting photo/memory speed dial, see page 19.

  Press a photo speed dial key on the telephone base to call.

----- OR -----
  Press **M1**, **M2** or **M3** on the handset to call.

Temporary tone dialing

If you have pulse (rotary) service only, you can switch from pulse to touch-tone dialing temporarily during a call. This is useful if you need to send touch-tone signals to access your telephone banking or long distance services.

①   ②  

When on a call, press **TONE*** on the handset or on the telephone base.

Enter the number you wish to dial. The telephone sends touch-tone signals. It automatically returns to pulse dialing mode after you end the call.

Audio Assist®

The **Audio Assist** feature enhances the clarity and loudness of your caller's voice on the cordless/corded handset earpiece when you are on a call, or listening to a message or an announcement.

Turn on/off Audio Assist:



When on a call or listening to a message or an announcement:

- Press **AUDIO ASSIST** on the telephone base or on the cordless handset to turn on.
- Press again to turn off.



Equalizer

The equalizer on the cordless handset and telephone base enable you to change the quality of the audio for both handset earpiece and speakerphone to best suit your hearing. The default setting is **Natural**.

Change the equalizer setting:

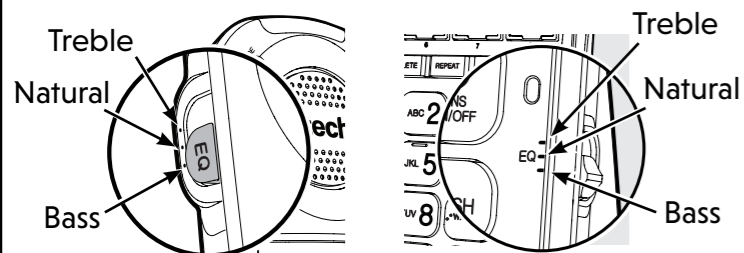

When on a call:

- Slide the **EQ** button to toggle among **Treble**, **Natural** and **Bass**.

Find handset

To find your misplaced cordless handset, press **PAGE/INTERCOM** on the telephone base to make intercom paging to the handset.

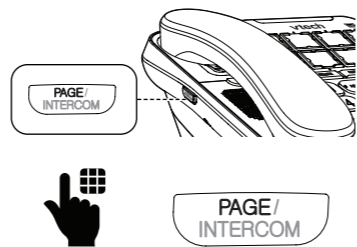

If you have two or more handsets, the telephone makes intercom paging to all handsets.

To stop the paging tone:

- Press **TALK** or  to answer the intercom call with the cordless handset; or
- Press **PAGE/INTERCOM** on the telephone base.

Join a call in progress

When you are already on an outside call with the cordless handset or the telephone base, the other handset or the telephone base can join the call.

To join a call with the cordless handset:



Press **TALK** or  on the handset.

To exit the call:

- Press **OFF** or place the handset in the handset charger; or
- Return the corded handset to the telephone base or press  on the telephone base.

To join a call with the telephone base:



Lift the corded handset or press  on the telephone base.



Operate

Intercom

You can use the intercom feature for conversations between the telephone base and the cordless handset. If you have two or more cordless handsets, you can make intercom calls from the telephone base to all cordless handsets, or from one handset to another or to the telephone base.

Make intercom call using the cordless handset:

1 Press **MENU** when the handset is not in use.

2 Scroll to **Intercom**, and then press **SELECT**.

NOTE

INTERCOM TO:
>HANDSET 2

- If you have other registered devices or have two or more handsets, choose the device to call.

Make intercom call using the telephone base:

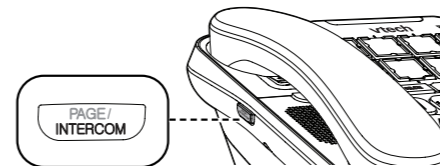

1



Lift the corded handset when the telephone is not in use.

2



PAGE/
INTERCOM

Press **INTERCOM**.

OR

1



PAGE/
INTERCOM

Press **INTERCOM** when the telephone is not in use.

2



Lift the corded handset.

NOTES

- To answer the intercom call on the destination devices:
 - On a cordless handset, press **TALK** or
 - On the telephone base, lift the corded handset or press
- To cancel an intercom call:
 - When using the cordless handset, press **OFF**.
 - When using the telephone base, press **INTERCOM**.



Call transfer using Intercom

Use the intercom feature to transfer an outside call from the cordless handset to the telephone base. You can also share an outside call with the telephone base.



When on a call with your cordless handset, press **MENU**.

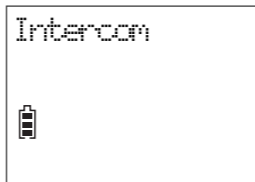

Press **SELECT** to select **Intercom**.

When the destination device picks up, the outside call is put on hold. Then, you have the following options:

- Transfer the call;
- Share the call; or
- End the call.

Transfer call:



Press **MENU**.

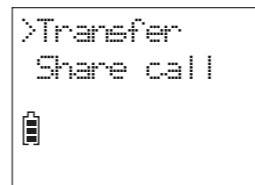

Press **SELECT** to select **Transfer**. The call is transferred to the destination device.

Share call:

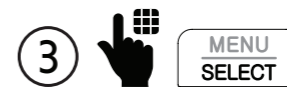

Press **MENU**.

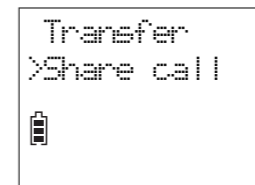

Scroll to **Share call**, and then press **SELECT** to let the destination device join you on the outside call in a three-way conversation.

End call:



Press **TALK**.

Press **TALK** to end the intercom call and continue the outside call with your handset.







Bluetooth®

Your telephone system is enhanced with Bluetooth feature. You can pair one Bluetooth headset to each of your **SN5147** cordless handsets. You can make or answer calls using a cordless handset or its paired Bluetooth headset.



Turn on Bluetooth feature



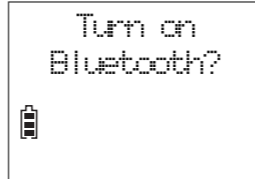

1   The Bluetooth feature is **Off** by default. To turn it **On**, press the Bluetooth key on the cordless handset.



2    Press **SELECT** to turn on Bluetooth feature.



Turn off Bluetooth feature

1   Press the Bluetooth key on the cordless handset.

BT On/Off
Pair headset

BLUETOOTH
XOFF

2   Press **SELECT** to choose **BT On/Off**.

3   Scroll to **Off** and then press **SELECT** again.

The Bluetooth® word mark and logos are owned by Bluetooth SIG, Inc. and any use of such marks by Advanced American Telephones and its parent, VTech Holdings Limited, is under license. VTech Holdings Limited is a member of Bluetooth SIG, Inc. Other trademarks and trade names are those of their respective owners.





Pair and connect a Bluetooth headset

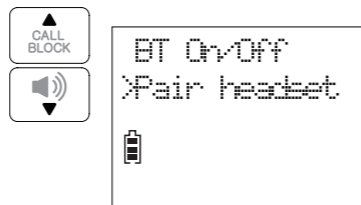

NOTES

- Before you begin, make sure that your Bluetooth enabled headset is turned on and is not connected to any other Bluetooth device. If you have trouble pairing your Bluetooth headset to your **SN5147** telephone system, try turning off the Bluetooth feature of the nearby devices that your Bluetooth headset has previously paired.
- Bluetooth wireless technology operates within a short range (a maximum of approximately 15 feet) from the cordless handset. Keep connected headset within this range.
- For more details about the Bluetooth feature, read the online Complete user's manual.

1 Set your Bluetooth headset to pairing mode. Refer to your Bluetooth headset user's manual to learn how. Place the Bluetooth headset next to the cordless handset.



2   Press the Bluetooth key on the cordless handset.

3   Scroll to **Pair headset** and then press **SELECT**.

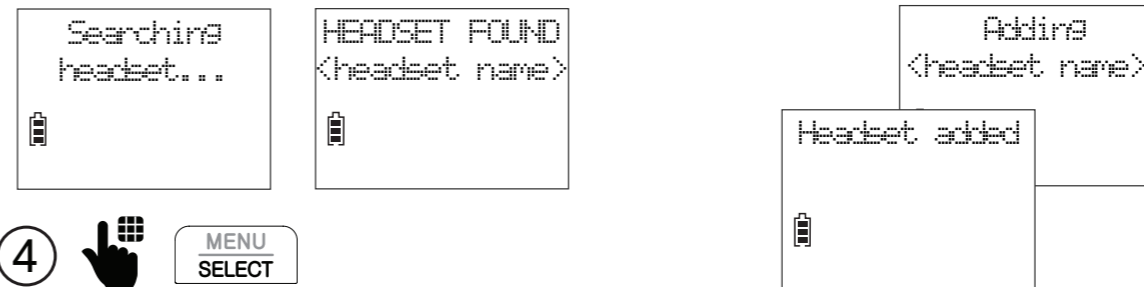

4  

When your Bluetooth headset is found and its name is displayed on the screen, press **SELECT**.

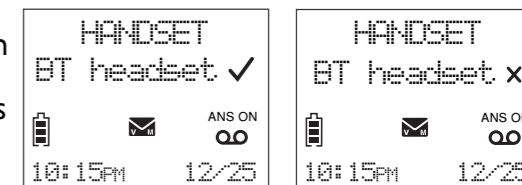

NOTES

- If the cordless handset cannot find any Bluetooth headset available while pairing, its screen shows **No headset found**. Move the Bluetooth headset closer to the cordless handset and re-try the pairing steps.
- If the cordless handset already has a Bluetooth headset paired to it when pairing, it prompts if you want to remove the currently paired one. Press **SELECT** to remove when prompted. The handset shows **BT headset removed**. You can then continue pairing the new Bluetooth headset.
- If the Bluetooth feature is on and the paired Bluetooth headset is connected to the cordless handset, the screen shows **BT headset ✓**. If the Bluetooth feature is on but the paired Bluetooth headset is disconnected, the screen shows **BT headset x**.





Make a call with Bluetooth headset Answer a call with Bluetooth headset

①   Enter the phone number.

- OR -

Search a number in the phonebook
(See **Review phonebook entry**).

- OR -

Search a number in the caller ID log
(See **Review caller ID log entry**).

- OR -

Search a number in the redial list
(See **Redial**).

②  

Press Bluetooth headset key.

When there is an incoming call,
press the Bluetooth headset
key to answer the call.

- OR -

If the Bluetooth headset is
connected, press the key on
your Bluetooth headset to answer the call (refer to
your Bluetooth headset's operation instructions).

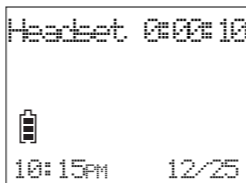

End a call with Bluetooth headset

Press **OFF** on the
cordless handset.

- OR -

Press the key on your
Bluetooth headset
to end the call (refer
to your Bluetooth
headset's operation
instructions).

Switch between cordless handset and Bluetooth headset

When you are on an outside call or intercom call using a cordless handset or its paired Bluetooth headset, you can switch between the two.

While on an outside call or intercom call with a cordless handset:

Press the Bluetooth headset key to
switch to its paired Bluetooth headset.

While on an outside call or intercom call with a connected Bluetooth headset:

Press the Bluetooth headset key to
switch to the cordless handset.

Mute the microphone during a call:

When you are on an outside call or
intercom call using a Bluetooth headset,
you can mute or unmute the microphone.





Press **MUTE** on the cordless
handset to mute the microphone.
Press again to unmute.

NOTE

- When you use your Bluetooth headset to make or answer calls, we recommend that you keep the connected cordless handset close to the Bluetooth headset, or bring along the cordless handset when you move around while using the Bluetooth headset.



Bluetooth headset name

Check the name of the paired Bluetooth headset.



Press the Bluetooth key on the cordless handset.



Scroll to **Headset name** and then press **SELECT**.

Remove Bluetooth headset



Press the Bluetooth key on the cordless handset.

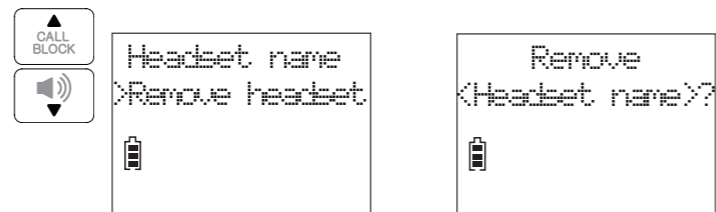

Scroll to **Remove headset** and then press **SELECT**.



Press **SELECT** to confirm.

Set auto connection / manual connection

Auto connection

- After you have paired a Bluetooth headset, you can set the cordless handset to automatically connect to the paired Bluetooth headset when it is within range of the cordless handset (default setting).

Manual connection

- If you choose to connect the paired Bluetooth headset manually, the cordless handset will connect to the paired Bluetooth headset when you press the Bluetooth key (Bluetooth icon) to make a call, or answer an outside call or intercom call. The Bluetooth headset will be disconnected after each call.

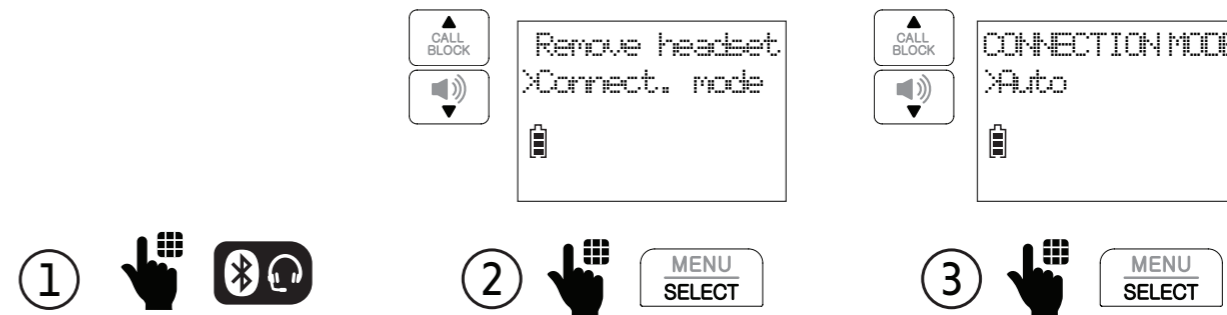

Press the Bluetooth key on the cordless handset.

Scroll to **Connect. mode** and then press **SELECT**.

Scroll to **Auto** or **Manual** and then press **SELECT** to set.



Phonebook

The phonebook can store up to 50 entries. Each entry may consist of a telephone number with up to 30 digits, and a name with up to 15 characters.

Add a phonebook entry

1 Enter the phone number when the handset is not in use.

2 Press **SELECT**.

3 Press **SELECT** again.

4 Enter the name

5 Press **SELECT**.

Saved to Phonebook

- OR -

1. Press **MENU** on the cordless handset when the telephone is not in use.
2. Scroll to **Phonebook**, and then press **SELECT**.
3. Scroll to **Add contact**, and then press **SELECT**.
4. Enter the phone number, and then press **SELECT**.
5. Enter the name, and then press **SELECT**.



Phonebook

Review phonebook entry

1

MENU
SELECT

Press **MENU** when the handset is not in use.

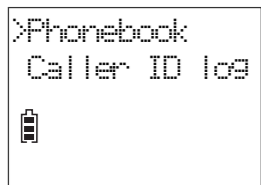

2

MENU
SELECT

Press **SELECT** to select **Phonebook**.

3

MENU
SELECT

Press **SELECT** to select **Review**.

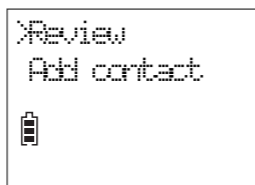

4

CALL
BLOCK

Scroll to browse through the entries.

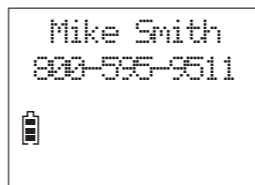

Dial a phonebook entry

Review the phonebook entries, and when your desired entry shows on the handset screen:



TALK
FLASH

Press **TALK** on the handset.

Delete a phonebook entry

Review the phonebook entries, and when your desired entry shows on the handset screen:



1

MUTE
DELETE

Press **DELETE**.

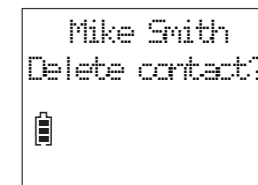

2

MENU
SELECT



Press **SELECT** to delete.



Phonebook

Save a redial entry to the phonebook

1   Press and hold **REDIAL** when the cordless handset is not in use.



 

REDIAL #1/10
595-9511



EDIT NUMBER
800-535-9511_

ENTER NAME
_



ENTER NAME
Mike Smith_

2  



Scroll to browse through the redial list. When your desired entry displays, press **SELECT**.

3  

Edit the phone number if needed, and then press **SELECT**.

4  

Enter the name.



5  

Press **SELECT** to save.

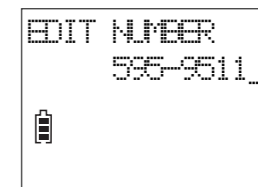
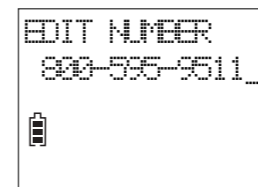

Edit a phonebook entry

Review the phonebook entries, and when your desired entry shows on the handset screen:





1  



Press **SELECT**.

2  



Edit the number.

3  

Press **SELECT**.

4  

Edit the name.

5  

Press **SELECT** to save.



Caller ID

If you subscribe to caller ID service, information about each caller appears after the first or second ring.

The caller ID log stores up to 50 entries. Each entry has up to 24 digits for the phone number and 15 characters for the name.

Review caller ID log entry

1 **MENU SELECT** Press **MENU** when the cordless handset is not in use.

2 **MENU SELECT**
Scroll to **Caller ID log**, and then press **SELECT**.

3 **MENU SELECT**
Press **SELECT** to select **Review**.

4 **CALL BLOCK**
Scroll to browse through the entries.

Save a caller ID log entry to the phonebook

When your desired caller ID log entry shows on the handset screen:

1 **MENU SELECT**
Press **SELECT**.

2 **MENU SELECT**
Press **SELECT**.

3 **1 2 3 4 5 6 7 8 9 0**
Edit the number if needed.

4 **MENU SELECT**
Press **SELECT**.

5 **1 2 3 4 5 6 7 8 9 0**
Edit the name if needed.

6 **MENU SELECT**
Press **SELECT** to save.



Caller ID

Dial a caller ID log entry

Review the caller ID log entries, and when your desired entry shows on the handset screen:



Press **TALK** on the handset.

Delete a caller ID log entry

Review the caller ID log entries, and when your desired entry shows on the handset screen:



Press **DELETE** on the handset.



Smart call blocker*

If you have subscribed to caller ID service, then you can use the Smart call blocker feature to screen incoming calls.

Smart call blocker is on, once you install your telephone. It allows all incoming calls to get through and ring by default. You can change the Smart call blocker settings to screen incoming calls.

With call screening active, Smart call blocker screens and filters all incoming calls from numbers or names that are not yet saved in your directory, allow list, block list, or star name list. You can easily add incoming phone numbers to your allow list and block list. This allows you to build up your lists of allowed and blocked numbers, and Smart call blocker will know how to deal with these calls when they come in again.

Read the **Introducing Smart call blocker** leaflet provided in your package to learn how to set up your Smart call blocker.

* Includes licenced Qaltel™ technology.
Qaltel™ is a trademark of Truecall Group Limited.



Smart call blocker

Call categories

Calls are classified into four categories. Smart call blocker handles the calls in the following ways:

CALL CATEGORY	CALL CONTROL
Welcome calls <ul style="list-style-type: none"> Numbers saved in allow list. Numbers saved in phonebook. Numbers not found in block list. Names saved in star name list. 	Allow The telephone rings when there is an incoming call with number saved in your allow list or phonebook, but not in your block list. Robocalls with caller names saved in your star name list will also ring.
Unwelcome calls <ul style="list-style-type: none"> Numbers saved in block list. 	Block The telephone does not ring when there is an incoming call with number saved in your block list, and the call will be rejected.

CALL CATEGORY	CALL CONTROL
Calls without numbers <ul style="list-style-type: none"> Numbers that are "out of area" or set to "Private". 	Option 1: Screening with caller name If you have selected this option, the telephone plays the screening announcement, and then asks the caller to say his/her name before the call rings on your telephone. You will then hear the caller's name announced if you have turned on the caller ID announce feature. Then, you can decide whether to accept or reject the call, or to forward the call to the answering system.
Uncategorized calls <ul style="list-style-type: none"> With absent caller ID number. Numbers not found in phonebook. Numbers not found in allow list. Numbers not found in block list. Caller ID names not found in star name list. 	Option 2: Screening without caller name If you have selected this option, the telephone plays the screening announcement, and then asks the caller to press the pound key (#) before the call rings on your telephone. You can then answer the call.
	Option 3: Allow (default settings) The telephone allows the calls to get through and ring. The caller's number will not be saved to the allow list.
	Option 4: Answering system If you have selected this option, the telephone forwards the calls to the answering system without ringing.
	Option 5: Block If you have selected this option, the telephone rejects the calls with block announcement without ringing. The caller's number will not be saved to the block list.



Smart call blocker

Set Smart call blocker on/off

1 Press **CALL BLOCK** when the handset is not in use.

2 Press **SELECT** to select **SCB On/Off**.

3 Scroll to **On** or **Off**, and then press **SELECT**.

Set welcome calls

Add allow list entry

Add numbers to the allow list that you want to allow their calls to get through to you. The allow list stores up to 200 numbers.

1 Press **CALL BLOCK** when the handset is not in use.

2 Scroll to **Allow list**, and then press **SELECT**.

3 Scroll to **Add new entry**, and then press **SELECT**.

4 Enter the phone number and name, and then press **SELECT** to save.



Smart call blocker

Set welcome calls

Add star name list entry

Add names (up to 15 characters) of organizations like schools, medical offices, and pharmacies that use robocalls to communicate important information to you. Their calls will get through to you. The star name list stores up to 10 names.

1 Press **CALL BLOCK** when the handset is not in use.

2 Scroll to **Star name list**, and then press **SELECT**.

3 Scroll to **Add new entry**, and then press **SELECT**.

4 Enter the name, and then press **SELECT** to save.

Set welcome calls

Save a caller ID log to the allow list

Review the caller ID log entries:

1. Press **MENU** when the handset is not in use.
2. Scroll to **Caller ID log**, and then press **SELECT**.
3. Press **SELECT** to select **Review**.

4 Browse through the entries. When the desired entry displays, press **SELECT**.

5 Scroll to **Allow list**, and then press **SELECT**.

6 Edit the phone number and name if needed, and then press **SELECT** to save.



Smart call blocker

Set welcome calls

Save a caller ID log to the star name list

Review the caller ID log entries:

1. Press **MENU** when the handset is not in use.
2. Scroll to **Caller ID log**, and then press **SELECT**.
3. Press **SELECT** to select **Review**.

4 MENU SELECT

5 MENU SELECT

6 MENU SELECT

Browse through the entries. When the desired entry displays, press **SELECT**.

Scroll to **Star name list**, and then press **SELECT**.

Press **SELECT** to save.

Set unwelcome calls

Add block list entry

Add numbers to the block list that you want to block them from calling. The block list stores up to 1,000 entries.

1 CALL BLOCK Press **CALL BLOCK** when the handset is not in use.

2 MENU SELECT

3 MENU SELECT

4 MENU SELECT

Scroll to **Block list**, and then press **SELECT**.

Scroll to **Add new entry**, and then press **SELECT**.

Enter the phone number and name, and then press **SELECT** to save.



Smart call blocker

Set unwelcome calls

Save a caller ID log to the block list

Review the caller ID log entries:

1. Press **MENU** when the handset is not in use.
2. Scroll to **Caller ID log**, and then press **SELECT**.
3. Press **SELECT** to select **Review**.



Browse through the entries. When the desired entry displays, press **SELECT**.

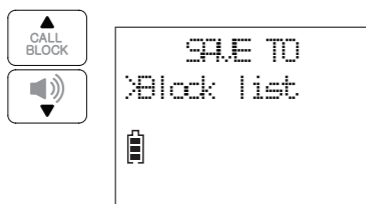

Scroll to **Block list**, and then press **SELECT**.



Edit the phone number and name if needed, and then press **SELECT** to save.

Control calls without numbers

Use this setting to control "out of area" calls or calls with numbers that are set to "Private". You can choose to allow or reject these calls directly. You can also choose to screen them with or without learning the callers' names before you decide whether to answer or reject these calls. Moreover, you can forward these calls to the answering system.



Press **CALL BLOCK** when the handset is not in use.



Scroll to **Calls w/o num**, and then press **SELECT**.



Scroll to select **Screening**, **Allow**, **Answering sys** or **Block**, and then press **SELECT**.

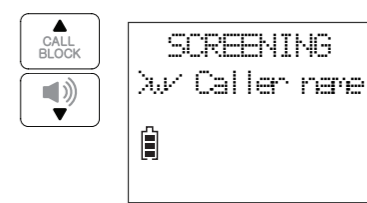

If you select **Screening**, scroll to select **w/Caller name** or **w/o Caller name**, and then press **SELECT**.



Smart call blocker

Control uncategorized calls

Use this setting to control calls with numbers that are not in your phonebook, allow list or block list, or have no caller ID number display. You can choose to allow or reject these calls directly. You can also choose to screen them with or without learning the callers' names before you decide whether to answer or reject these calls. Moreover, you can forward these calls to the answering system.

1 Press **CALL BLOCK** when the handset is not in use.

2 Scroll to **Uncategorized**, and then press **SELECT**.

3 Scroll to select **Screening**, **Allow**, **Answering sys** or **Block**, and then press **SELECT**.

4 If you select **Screening**, scroll to select **w/Caller name** or **w/o Caller name**, and then press **SELECT** when done.

Screen calls without numbers

If Smart call blocker is on, and you have set to screen calls without numbers, the telephone will not ring when receiving calls without numbers. It plays the screening announcement to the caller and asks the caller to respond before putting the call through to you.

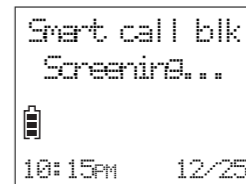

The telephone is playing the screening announcement to the caller.

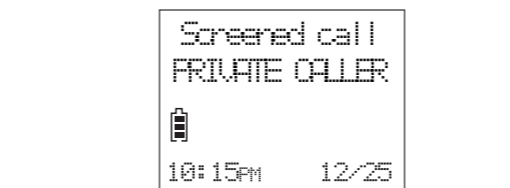

If you have selected **w/Caller name** to ask callers to say their names:

After you pick up the call, the telephone announces:

"To answer the call, press 1. To send this call to the answering system, press 4. To repeat these options, press *".



After screening, the telephone rings. Press **TALK** or to pick up the call.

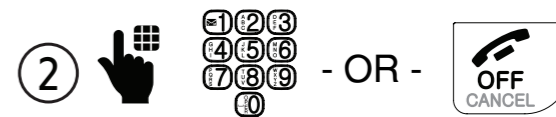

- Press **1** to answer the call;
- Press **4** to send it to the answering system; or
- Press **OFF** to hang up.



Smart call blocker

Screen uncategorized calls

If Smart call blocker is on, and you have set to screen uncategorized calls, the telephone will not ring when receiving these calls. It plays the screening announcement to the caller and asks the caller to respond before putting the call through to you.

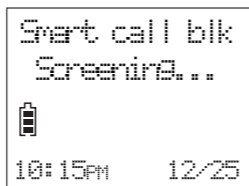

The telephone is playing the screening announcement to the caller.

If you have selected **w/Caller name** to ask callers to say their names:

After you pick up the call, the telephone announces:

*"To answer the call, press 1. To answer and always allow this number, press 2. To block this number, press 3. To send this call to the answering system, press 4. To repeat these options, press *".*

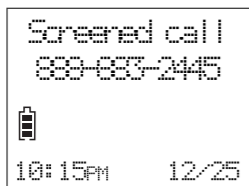

After screening, the telephone rings. Press **TALK** or to pick up the call.



- Press **1** to answer the call;
- Press **2** to answer and always allow this number;
- Press **3** or **CALL BLOCK** to block the call; or
- Press **4** to send it to the answering system; or
- Press **OFF** to hang up.

Add a screened number to the allow list or block list

When the telephone announces the screening options after you pick up a screened call:

*"To answer the call, press 1. To answer and always allow this number, press 2. To block this number, press 3. To send this call to the answering system, press 4. To repeat these options, press *".*

Add a screened number to the allow list



Press **2** to answer the call. The telephone will add the current number to the allow list.

Add a screened number to the block list



Press **3** or **CALL BLOCK** to block the call. The telephone will add the current number to the block list.

Option while on a call

When you are on a call and speaking to the caller, and you do not want to continue the call, you can end the call with block announcement and add the number to the block list.

1. During a call, press **CALL BLOCK**.
2. Press **SELECT** to end the call.





Answering system

About the built-in answering system and voicemail service



For message recording, your telephone has a built-in answering system, and it also supports voicemail service offered by your **telephone service provider** (subscription is required, and fee may apply).

Built-in answering system VS Voicemail service

	BUILT-IN ANSWERING SYSTEM	VOICEMAIL SERVICE
SUPPORTED BY	Telephone system	Telephone service provider
SUBSCRIPTION	No	Yes
FEES	No	May apply
ANSWER INCOMING CALLS	<ul style="list-style-type: none"> After 4 rings by default. It can be changed via handset menu. 	<ul style="list-style-type: none"> Usually after 2 rings. It can be changed by contacting your telephone service provider.

BUILT-IN ANSWERING SYSTEM

VOICEMAIL SERVICE

STORAGE	Telephone base	Server or System
DISPLAY NEW MESSAGES	<ul style="list-style-type: none"> Handset - XX New messages 	<ul style="list-style-type: none"> Handset -  and New voicemail
RETRIEVE MESSAGES	<ul style="list-style-type: none"> Press ▶/■ on the telephone base; OR Press MENU, and then select Play messages on the handset; OR Access remotely with an access code. 	<ul style="list-style-type: none"> Press and hold  on the dialpad, and enter an access number and/or passcode from your telephone service provider.



Answering system

Turn the built-in answering system on or off

On the telephone base:



Press **ANS ON/OFF**.

Set number of rings

You can set your answering system to answer calls at least two rings earlier than your voicemail service. For example, if your voicemail service answers after six rings, set your answering system to answer after four rings. Thus, if you are on a call, or if the answering system is busy recording a message and you receive another call, the second caller can leave a voicemail message.

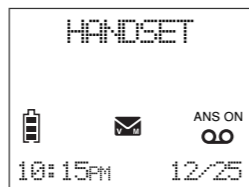

1



MENU
SELECT

Press **MENU** when the handset is not in use.

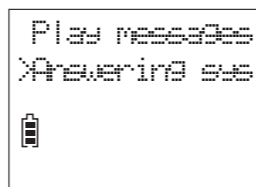

2



MENU
SELECT

Scroll to **Answering sys**, and then press **SELECT**.

Set number of rings

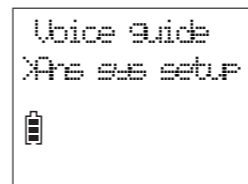

3



MENU
SELECT

Scroll to **Ans sys setup**, and then press **SELECT**.

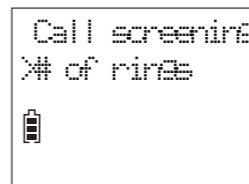

4



MENU
SELECT

Scroll to **# of rings**, and then press **SELECT**.

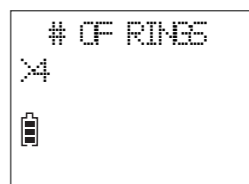

5



MENU
SELECT

Select **6, 5, 4, 3, 2** or **Toll saver**, and then press **SELECT**.

NOTE

- If you select **Toll saver**, the answering system answers a call after two rings when you have new messages, and after four rings when there are no new messages. This feature allows you to check for new messages and avoid paying long distance charges when calling from out of your local area.



Answering system

Message playback

On the telephone base:



- OR -

On the cordless handset:

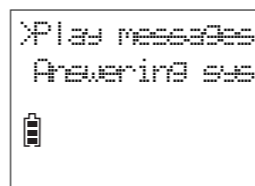
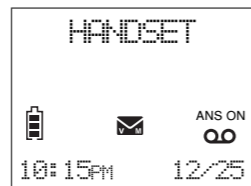

Press **MENU** when the handset is not in use.



Press **SELECT** to select **Play messages**.

TIP

- While playing back a message on the telephone base, you can press  to reduce the playback speed.

Skip a message

If you are using the cordless handset to play messages, you can skip a message.

On the cordless handset:



Repeat the playing message

On the telephone base:



- OR -

On the cordless handset:





Answering system

Play the previous message

On the telephone base:



Press **REPEAT** twice.

OR

On the cordless handset:



Press **4** twice.

Delete a message

When message is playing:

On the telephone base:



- OR -

On the cordless handset:



Delete all messages

On the telephone base:



On the cordless handset:



Scroll to **Answering sys**, then press **SELECT**.



Scroll to **Delete all old**, then press **SELECT**.



Press **SELECT** again to confirm.



Answering system

Remote access

You can reach your answering system remotely by dialing your home telephone number from any touch-tone telephone. A two-digit security code is required. The preset code is **19**. You can set the code from **00** to **99**.

- ① To access your answering system remotely, dial your telephone number from any touch-tone telephone.
- ② When the system plays your answering system announcement, "Hello. Please leave a message after the tone.", enter the two-digit security code.
- ③ Enter one of the remote commands.

COMMAND	DESCRIPTION
1	Play all messages.
2	Play only new messages.
3	Delete the current message (during playback).
33	Delete all old messages.
4	Repeat the current message (during playback).
5	Stop.
*5	Hear a list of remote commands.
6	Skip to the next message (during playback).
*7	Record a new announcement.
8	End the call.
0	Turn the answering system on or off.

Set remote access code

You can set your own remote access code from **00** to **99**.

The diagram illustrates the process of setting a remote access code through a handset's menu system. It is divided into two main sections by a dashed line.

Top Section:

- Step 1:** Press **MENU SELECT** when the handset is not in use. The screen shows a menu with options: "Play messages", "Voice guide", and "# of rings".
- Step 2:** Scroll to **Answering sys** and press **SELECT**. The screen shows "Play messages" and "Answering sys".
- Step 3:** Scroll to **Ans sys setup** and press **SELECT**. The screen shows "Voice guide" and "Ans sys setup".
- Step 4:** Scroll to **Remote code** and press **SELECT**. The screen shows "# of rings" and "Remote code".

Bottom Section:

- Step 5:** Enter a two-digit number. The screen shows "REMOTE CODE" with "19" entered.
- Step 6:** Press **SELECT** to save. The screen shows "REMOTE CODE" with "99" entered.



Additional devices

Add and register expansion handset

You can add new cordless handsets (**SN5107**, purchased separately) to expand your telephone system. Your telephone base supports a maximum of four cordless handsets. Additional handsets are assigned with numbers in sequential order.

Charge the new handset without interruption for at least 30 minutes before registering it to the telephone base. After charged, each expansion handset displays **To register HS, see manual**.

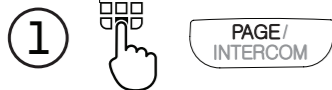
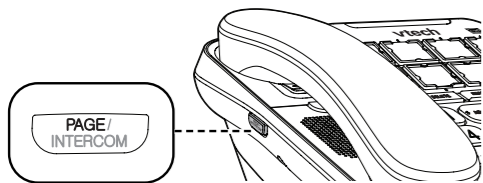

When the telephone is not in use, press and hold **PAGE** on the telephone base for about five seconds until the visual ringer indicator light turns on. Release **PAGE**.

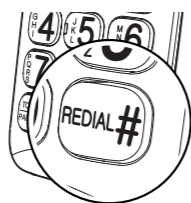

Press the pound (#) key on the handset to register.

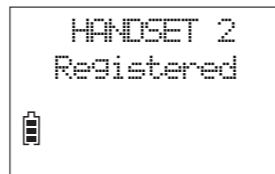
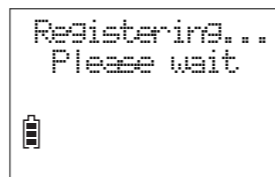

When the registration is successful, the handset displays **HANDSET X Registered**.

Add and register photo speed dial handset

You can add a new photo speed dial handset (**SN5307**, purchased separately) to your telephone system. The **SN5307** cordless photo speed dial handset lets you quickly dial one of the four preset numbers by just pressing the photo speed dial key.

If you have already set the direct memory speed dial keys **1**, **2**, **3** and **4** on the telephone base, the same numbers will be automatically set for the dial keys of your newly registered photo speed dial handset.

You can register a maximum of four cordless handsets.

You need to register your new photo speed dial handset to the telephone base before use.

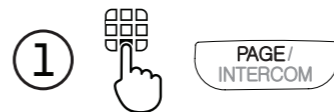
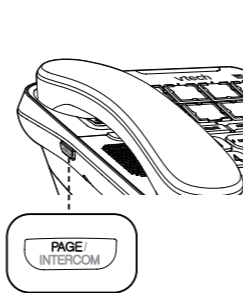

When the telephone is not in use, press and hold **PAGE** on the telephone base for about five seconds until the visual ringer indicator light turns on. Release **PAGE**.

Put the handset on its charger to begin registration. The handset **CHARGE** light alternates red and green quickly to indicate the registration is in progress.

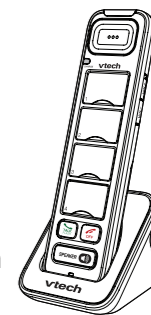

For registration and detailed operations, read the user's manual of your new photo speed dial handset provided in your package.



Additional devices

Device setup

You can add VTech compatible Cordless audio doorbell and ULE Wearable home SOS pendant (**SN7021** and **SN7022**, both purchased separately) to your telephone system.

The Cordless audio doorbell (**SN7021**) helps you get notified at your telephone system upon visitors' arrival. When a visitor presses the Audio doorbell, both the base and the handset will play the chime tone, and you can then answer the doorbell call and talk to the visitor at your door with the handset or base. For operation instructions, refer to page 94 to page 105.

The ULE Wearable home SOS pendant (**SN7022**) function as same as the SOS button of your cordless handset. It acts as a handy pendant to let you quickly call the preset SOS numbers for help in an emergency, even when your telephone is beyond your reach. For detailed setups and operations, refer to **Set SOS emergency call** section on page 13 to page 18, and **Make SOS emergency call** section on page 38.

NOTE

- You can add a maximum of two Cordless audio doorbells and 30 compatible ULE devices to your telephone base.

NOTES

- You need to register your newly purchased devices to the telephone base before use.
- Make sure the new devices are powered on with batteries or with AC power before registering them to the telephone base.

Add and register a new device

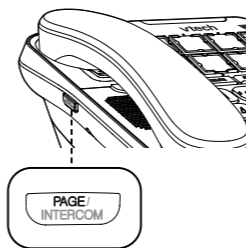

1



When the telephone is not in use, press and hold **PAGE** on the telephone base for about five seconds until the visual ringer indicator light turns on. Release **PAGE**.

2

Audio doorbell

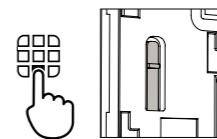

Press and hold the pair button on the back of the audio doorbell until the chime button LED light flashes, then release the pair button. When registration is successful, the chime button LED light becomes steady on, and then the base beeps once.

SOS pendant

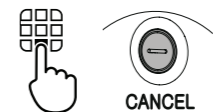

Press and hold **CANCEL** on the back of the SOS pendant until the LED light on the front flashes, then release the button. When registration is successful, the LED light turns off, and then the base beeps once.



Additional devices

Audio doorbell

(Model **SN7021** , purchased separately)

If you have purchased and registered an Cordless audio doorbell (**SN7021**) to the telephone base, the **Doorbell** sub-menu option appears in the **Set device** menu of the cordless handset. You can set up your Cordless audio doorbell, for example, set the chime volume and tone, and divert doorbell calls to a preset number. You can also record doorbell calls.

Set chime volume

1 Press **MENU SELECT** on the handset when it is not in use.

2 Scroll to **Set device**, and then press **SELECT**.

3 Scroll to **Doorbell**, and then press **SELECT**.

4 Press **SELECT** to select **Chime**.

5 Press **SELECT** again to select **Chime volume**.

6 Scroll to select from **Volume 1** to **Volume 5**, or select **Off**, and then press **SELECT**.



Additional devices

Audio doorbell

(Model **SN7021** , purchased separately)

Set chime tone

1 Press **MENU** when the handset is not in use.

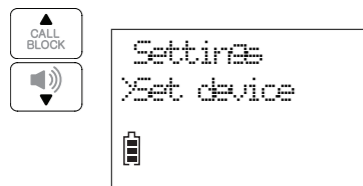

2 Press **MENU**

Scroll to **Set device**, and then press **SELECT**.



3 Press **MENU**

Scroll to **Doorbell**, and then press **SELECT**.

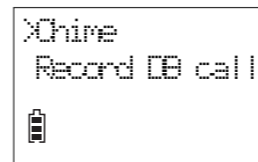

4 Press **MENU**

Press **SELECT** to select **Chime**.

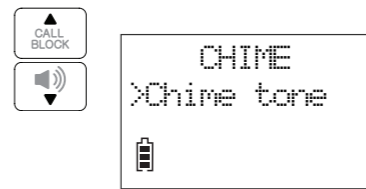

5 Press **MENU**

Scroll to **Chime tone**, and then press **SELECT**.



6 Press **MENU**

Scroll to select from **Tone 1** to **Tone 5**, or select **Off**, and then press **SELECT**.



Additional devices

Audio doorbell (Model SN7021 , purchased separately)

When a visitor presses your audio doorbell, all your devices chime and the handset screen shows **Doorbell X is ringing**.

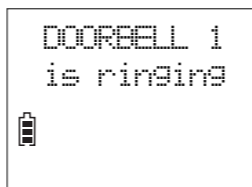

Answer a doorbell call

Using a cordless handset:



Press **TALK** on a cordless handset to answer.

Using the telephone base:



Press on the telephone base or lift the corded handset to answer.

Decline a doorbell call

Using a cordless handset:



When the chime tone is ringing, press **OFF** on the handset.

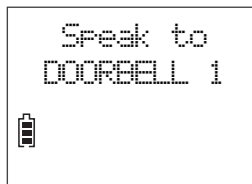

NOTE

- After you press **TALK** on the cordless handset to answer the doorbell, the handset screen displays **Speak to DOORBELL X**. You can then talk with the visitor at your door.

Record doorbell call

You can record conversations between you at the telephone and the visitor at your door. Your telephone is set to record all doorbell calls by default. You can disable the setting.



Press **MENU** on the handset when it is not in use.

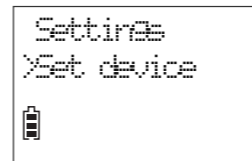

Scroll to **Set device**, and then press **SELECT**.

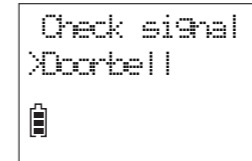

Scroll to **Doorbell**, and then press **SELECT**.

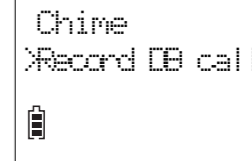

Scroll to **Record DB call** and press **SELECT**. Then, scroll to **On** or **Off**, and press **SELECT**.

NOTE

- Recorded doorbell calls are stored as voice messages. See **Message playback** section on page 84 to retrieve your doorbell call conversations.



Additional devices

Audio doorbell (Model **SN7021** , purchased separately)

You can divert all doorbell calls to a preset external number, or decline a doorbell call and forward the doorbell call to the preset external number.

Set call divert number

1 Press **MENU** on the handset when it is not in use.

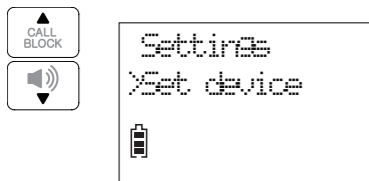

2 Press **MENU** on the handset.

Scroll to **Set device**, and then press **SELECT**.



3 Press **MENU** on the handset.

Scroll to **Doorbell**, and then press **SELECT**.



4 Press **MENU** on the handset.

Scroll to **Dbell divert**, and then press **SELECT**.

NOTE

When a visitor presses the doorbell and the doorbell call is diverted to the preset number, the call receiver of the preset number hears the message *"This is a diverted call from doorbell. Please press any number key to start the conversation."* Your telephone is set to record all doorbell call conversations by default. You can disable the setting. See **Record doorbell call** on page 99.

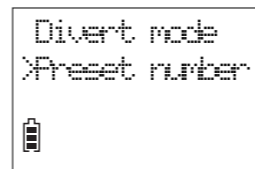

5 Press **MENU** on the handset.

Scroll to **Preset number**, and then press **SELECT**.

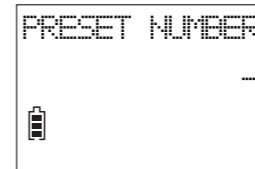

6 Press **MENU** on the handset.

Enter the destination number.

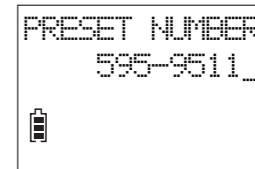

7 Press **MENU** on the handset.

Press **SELECT** to save.



Additional devices

Audio doorbell (Model **SN7021** , purchased separately)

You can set your audio doorbell to divert all doorbell calls to the preset external number when visitors press the doorbell.

Set auto call divert to preset number

①   Press **MENU** on the handset when it is not in use.



②  

Scroll to **Set device**, and then press **SELECT**.



③  

Scroll to **Doorbell**, and then press **SELECT**.

NOTE

To cancel all call diverts to the preset number:

1. Repeat from step 1 to step 5.
2. Then, at step 6, scroll to **Off** and then press **SELECT**.

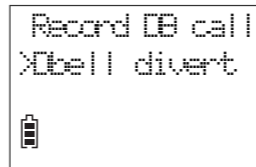

④  

Scroll to **Dbell divert**, and then press **SELECT**.

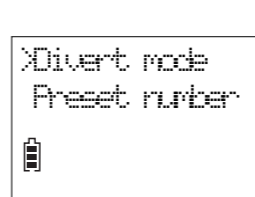

⑤  

Press **SELECT** to select **Divert mode**.

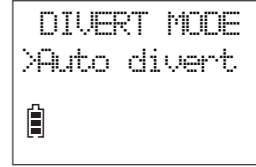

⑥  

Scroll to **Auto divert**, and then press **SELECT**.



Additional devices

Audio doorbell (Model **SN7021** , purchased separately)

You can also set up call divert to the preset number, only when you press **OFF** on your handset to decline the doorbell call.

Set declined call divert to preset number

①   Press **MENU** on the handset when it is not in use.



②  

Scroll to **Set device**, and then press **SELECT**.



③  

Scroll to **Doorbell**, and then press **SELECT**.

NOTE

To cancel all call diverts to the preset number:

1. Repeat from step 1 to step 5.
2. Then, at step 6, scroll to **Off** and then press **SELECT**.

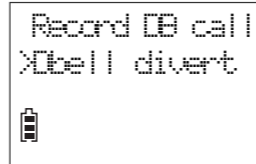

④  

Scroll to **Dbell divert**, and then press **SELECT**.

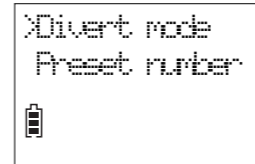

⑤  

Press **SELECT** to select **Divert mode**.

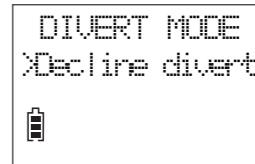

⑥  

Scroll to **Decline divert**, and then press **SELECT**.



Additional devices

Test device signal strength

You can check the signal strength of your devices (**SN7021/SN7022**, both purchased separately), for example, before mounting it. Follow the instructions below to check the signal strength between the device and the telephone base. For Audio doorbell (**SN7021**), make sure you mount them in a location where the signal strength is good.

1 **MENU SELECT** Press **MENU** on the handset when it is not in use.

2 **MENU SELECT** Scroll to **Set device**, and then press **SELECT**.

3 **MENU SELECT** Press **SELECT** to select **Check signal**.

4 **MENU SELECT** Scroll to select the desired device, and then press **SELECT**.

5 When the handset displays **Awaiting signal**:

Audio doorbell

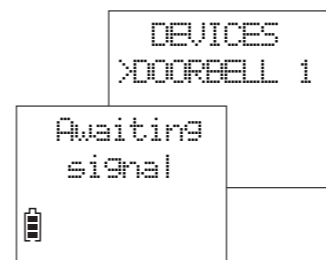

Press the chime button on the audio doorbell.

SOS pendant

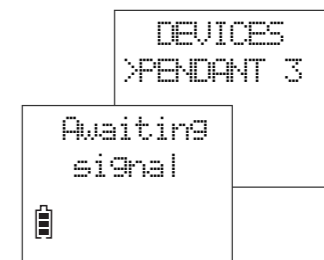

Press the **CANCEL** button on the audio doorbell.

- OR -



TIP

When the handset displays **Good signal**, press **SELECT** to confirm.

- If the handset displays **No signal** or **Weak signal**, check your device and make sure it is powered on, or select another location nearer to the telephone base.



Additional devices

Device monitoring

If there are additional devices registered to the telephone base, the names of the registered devices appear in the **Devices** menu of the cordless handset.

You can view the current status of each of the registered devices and check whether they are active, inactive, or with low battery.

View device status

1 Press **MENU SELECT** on the handset when it is not in use.

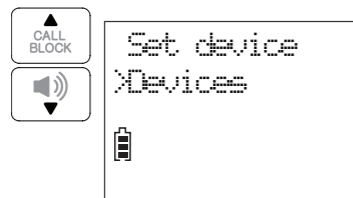

2 **MENU SELECT**

Scroll to **Devices**, and then press **SELECT**.

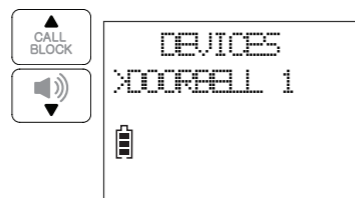

3 **MENU SELECT**

Scroll to the desire device, and press **SELECT**.

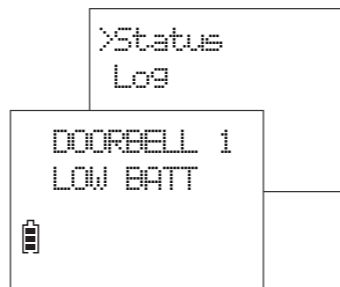

4 **MENU SELECT**

Press **SELECT** to select **Status** and view the current status of the device.

Need help?

For operations and guides to help you using your telephone, and for the latest information and supports, go and check the online help topics and online FAQs.

Use your smartphone or mobile device to access our online help.

- Go to <https://help.vtechphones.com/SN5147> (US); OR <https://phones.vtechcanada.com/en/support/general/manuals?model=SN5147> (Canada)

- Scan the QR code on the right. Launch the camera app or QR code scanner app on your smartphone or tablet. Hold the device's camera up to the QR code and frame it. Tap the notification to trigger the redirection of the online help.

- If the QR code is not clearly displayed, adjust your camera's focus by moving your device closer or further away until it is clear.

You can also call our Customer Support at 1 (800) 595-9511 [in US] or 1 (800) 267-7377 [in Canada] for help.



SN5147 (US)



SN5147 (CA)

Limited warranty

What does this limited warranty cover?

The manufacturer of this VTech Product warrants to the holder of a valid proof of purchase ("Consumer" or "you") that the Product and all accessories provided in the sales package ("Product") are free from defects in material and workmanship, pursuant to the following terms and conditions, when installed and used normally and in accordance with the Product operating instructions. This limited warranty extends only to the Consumer for Products purchased and used in the United States of America and Canada.

What will VTech do if the Product is not free from defects in materials and workmanship during the limited warranty period ("Materially Defective Product")?

During the limited warranty period, VTech's authorized service representative will replace at VTech's option, without charge, a Materially Defective Product. If we replace the Product, we may use new or refurbished replacement parts. If we choose to replace the Product, we may replace it with a new or refurbished Product of the same or similar design. We will retain defective parts, modules, or equipment. Replacement of the Product, at VTech's option, is your exclusive remedy. VTech will return the replacement Products to you in working condition. You should expect the replacement to take approximately 30 days.

How long is the limited warranty period?

The limited warranty period for the Product extends for ONE (1) YEAR from the date of purchase. If VTech replaces a Materially Defective Product under the terms of this limited warranty, this limited warranty also applies to the replacement Product for a period of either (a) 90 days from the date the replacement Product is shipped to you or (b) the time remaining on the original one-year warranty; whichever is longer.

What is not covered by this limited warranty?

This limited warranty does not cover:

1. Product that has been subjected to misuse, accident, shipping or other physical damage, improper installation, abnormal operation or handling, neglect, inundation, fire, water or other liquid intrusion.
2. Product that has been subjected to contact with liquid, water, rain, extreme humidity or heavy perspiration, sand, dirt or the like; but then only to the extent the damage was not caused by incorrectly securing the waterproof handset's protective elements, for example, failing to properly close a seal, or such protective elements are damaged or missing (e.g. a cracked battery door), or subjecting a Product to conditions beyond its stated specifications or limits (e.g. 30 minutes in 1 meter of fresh water).
3. Product that has been damaged due to repair, alteration or modification by anyone other than an authorized service representative of VTech;
4. Product to the extent that the problem experienced is caused by signal conditions, network reliability, or cable or antenna systems;
5. Product to the extent that the problem is caused by use with non-VTech accessories;
6. Product whose warranty/quality stickers, product serial number plates or electronic serial numbers have been removed, altered or rendered illegible;
7. Product purchased, used, serviced, or shipped for repair from outside the United States of America or Canada, or used for commercial or institutional purposes (including but not limited to Products used for rental purposes);
8. Product returned without a valid proof of purchase (see item 2 below); or
9. Charges for installation or set up, adjustment of customer controls, and installation or repair of systems outside the unit.

How do you get warranty service?

To obtain warranty service in the United States of America, please visit our website at www.vtechphones.com or call 1 (800) 595-9511. In Canada, go to phones.vtechcanada.com or dial 1 (800) 267-7377.

NOTE: Before calling for service, please review the user's manual - a check of the Product's controls and features may save you a service call.

Except as provided by applicable law, you assume the risk of loss or damage during transit and transportation and are responsible for delivery or handling charges incurred in the transport of the Product(s) to the service location. VTech will return replaced Product under this limited warranty. Transportation, delivery or handling charges are prepaid.

VTech assumes no risk for damage or loss of the Product in transit. If the Product failure is not covered by this limited warranty, or proof of purchase does not meet the terms of this limited warranty, VTech will notify you and will request that you authorize the cost of replacement prior to any further replacement activity. You must pay for the cost of replacement and return shipping costs for the replacement of Products that are not covered by this limited warranty.

What must you return with the Product to get warranty service?

1. Return the entire original package and contents including the Product to the VTech service location along with a description of the malfunction or difficulty; and
2. Include a "valid proof of purchase" (sales receipt) identifying the Product purchased (Product model) and the date of purchase or receipt; and
3. Provide your name, complete and correct mailing address, and telephone number.

Other limitations

This warranty is the complete and exclusive agreement between you and VTech. It supersedes all other written or oral communications

related to this Product. VTech provides no other warranties for this Product. The warranty exclusively describes all of VTech's responsibilities regarding the Product. There are no other express warranties. No one is authorized to make modifications to this limited warranty and you should not rely on any such modification.

State/Provincial Law Rights: This warranty gives you specific legal rights, and you may also have other rights, which vary from state to state or province to province.

Limitations: Implied warranties, including those of fitness for a particular purpose and merchantability (an unwritten warranty that the Product is fit for ordinary use) are limited to one year from the date of purchase. Some states/provinces do not allow limitations on how long an implied warranty lasts, so the above limitation may not apply to you. In no event shall VTech be liable for any indirect, special, incidental, consequential, or similar damages (including, but not limited to lost profits or revenue, inability to use the Product or other associated equipment, the cost of substitute equipment, and claims by third parties) resulting from the use of this Product. Some states/provinces do not allow the exclusion or limitation of incidental or consequential damages, so the above limitation or exclusion may not apply to you.

Please retain your original sales receipt as proof of purchase

Disclaimer and Limitation of Liability



VTech Communications, Inc. and its suppliers assume no responsibility for any damage or loss resulting from the use of this user's manual. VTech Communications, Inc. and its suppliers assume no responsibility for any loss or claims by third parties that may arise through the use of this product.

Company: VTech Communications, Inc.

Address: 9020 SW Washington Square Road - Ste 555 Tigard, OR 97223, United States

Phone: 1 (800) 595-9511 in the U.S. or 1 (800) 267-7377 in Canada

Technical specifications

Frequency control	Crystal controlled PLL synthesizer
Transmit frequency	Handset: 1921.536-1928.448 MHz Telephone base: 1921.536-1928.448 MHz
Channels	5
Nominal effective range	Maximum power allowed by FCC and IC. Actual operating range may vary according to environmental conditions at the time of use.
Power requirement  	Handset: 1.2V 500mAh, 3 x AAA Ni-MH battery Telephone base: 6V DC @ 800mA Charger: 6V DC @ 400mA
Memory	Phonebook: 50 memory locations; up to 30 digits and 15 characters Caller ID log: 50 memory locations; up to 24 digits and 15 characters Call block: 1000 entries

The Bluetooth® word mark and logos are owned by Bluetooth SIG, Inc. and any use of such marks by Advanced American Telephones and its parent, VTech Holdings Limited, is under license. VTech Holdings Limited is a member of Bluetooth SIG, Inc. Other trademarks and trade names are those of their respective owners.

Audio Assist® is a registered trademark of Advanced American Telephones.

Qaltel™ is a trademark of Truecall Group Limited.



Recycle this product when you are done with it

Scan the QR code on the right or visit

www.vtechphones.com/recycle.

(For the US only)



Specifications are subject to change without notice.

© 2024 VTech Communications, Inc. |

© 2024 VTech Technologies Canada Ltd.

All rights reserved. 01/24.

SN5147_UG_V1_BT_Y

