



-  ranein.net
-  service@ranein.net
-  business@ranein.net

Rv Tankless Water Heater

Instruction For Installation And Use

WARRANTY

Limited Warranty

Ranein provides a one-year warranty for customers who purchase from the Ranein store or the official Ranein website.

Warranty Period

The warranty begins from the date of purchase by the original purchaser. Please provide a screenshot of the order from the website to confirm the warranty start date.

Tips

If there is any issue with the product, you can provide us with pictures and videos for confirmation. After the technicians confirm the issue, we will offer return and exchange services.

Customer Support

www.ranein.net

service@ranein.net

⚠ WARNING

Failure to follow the instructions in this manual could result in fire or explosion, causing property damage, personal injury, or death.

- Do not store or use gasoline or other flammable vapors and liquids near this appliance or any other appliance.

- WHAT TO DO IF YOU SMELL GAS

- Evacuate all persons from the vehicle.
- Shut off the gas supply at the gas container or source.
- DO NOT touch any electrical switches or use any phones or radios in the vehicle.
- DO NOT start the vehicle's engine or electric generator.
- Contact the nearest gas supplier or qualified service technician for repairs.
- Contact the nearest fire department if you cannot reach a gas supplier or qualified service technician.
- DO NOT turn on the gas supply until the leak(s) are repaired.

- Installation and service must be performed by a qualified installer, service agency, or gas supplier.

EXCLUSIONS

Thank you for purchasing this Ranein® product. Before operating your new product, please read these instructions carefully to ensure safe use and reduce the risk of injury. This manual also contains important information for installation, operation, and maintenance, as well as service guidelines. Please keep this manual in a safe place for future reference, and pass it on to any new owners of the product. The manufacturer does not accept responsibility for damages resulting from failure to follow these instructions.

⚠ WARNING

What to Do If You Smell Gas

- Evacuate all persons from the vehicle.
- Shut off the gas supply at the gas container or source.
- Do not touch any electrical switches or use any phones or radios in the vehicle.
- Do not start the vehicle's engine or electric generator.
- Contact the nearest gas supplier or certified service technician for repairs.
- Contact the nearest fire department if you cannot reach a gas supplier or accredited service technician.
- Do not turn on the gas supply until the leaks are repaired.

TABLE OF CONTENTS

WARRANTY.....	1
EXCLUSIONS.....	1
Explanation of Symbols.....	3
Important Safety Instructions	3
Operator's Responsibilities.....	4
About Your Product	5-10
Installation.....	11-19
Water Heater Installation	19-25
Wiring Diagram.....	26
Check After.....	26-27
Operation Instruction.....	28-30
Winterizing Operation.....	30-34
Storage and Transit.....	34-36
Troubleshooting.....	36-38

The color of the operating instructions corresponding to each model:

(RA65EH)

(RA65LH/RA65SH)

(RA65ZH)

Explanation of Symbols

This manual contains safety information and instructions to help you eliminate or reduce the risk of accidents and injuries.

Always heed all safety warnings marked with these symbols. A signal word will accompany safety messages and property damage warnings to indicate the level of hazard seriousness.

⚠ DANGER

Indicates a potentially hazardous situation that, if not avoided, could lead to death or serious injury.

⚠ WARNING

Indicates a potentially hazardous situation that, if not avoided, could result in death or serious injury.

⚠ CAUTION

Indicates a potentially hazardous situation that, if not avoided, may result in minor or moderate personal injury or property damage.

Important Safety Instructions

Read these instructions carefully to ensure the safe and correct operation of your appliance. Retain the instruction manual and installation guidelines for future reference or for subsequent owners.

⚠ DANGER

Suffocation or Fire Hazard

Exhaust gases are hot and contain carbon monoxide. Do not breathe in or obstruct the exhaust gases.

Failure to follow these instructions may result in serious injury, property damage, or death.

- Never use this appliance in enclosed spaces or tents.
- Always turn off the appliance and shut off the fuel supply when parking the RV in an enclosed space, such as a garage or repair shop.
- Never place seating or picnic tables directly in the path of the exhaust outlet.
- DO NOT use this RV water heater without a working carbon monoxide detector. Follow the manufacturer's instructions for its installation.
- ALWAYS keep the air inlet and exhaust outlet free of obstructions to ensure clean combustion.
- DO NOT place articles on or against the appliance.
- DO NOT lean any objects against the water heater's access door or place any foreign objects near it.
- Do not use this appliance in enclosed spaces or tents.
- Always turn off the appliance and shut off the fuel supply when parking the RV in an

enclosed space, such as a garage or repair shop.

- Never place seating or picnic tables directly in the path of the exhaust outlet.
- DO NOT use this RV water heater without a working carbon monoxide detector. Follow the manufacturer's instructions and guidelines for its installation.
- ALWAYS keep the air inlet and exhaust outlet free of obstructions to ensure clean combustion.
- DO NOT place articles on or against the appliance.
- DO NOT lean any objects against the water heater's access door or place any foreign objects within 24" (610 mm) of the access door.
- DO NOT use or store flammable materials near the appliance.
- DO NOT spray aerosols near the appliance while it is in operation.
- DO NOT modify the appliance.

Operator's Responsibilities

- The operator is responsible for their health and safety. Persons with pacemakers should consult their doctor before opening the access door or performing service repairs.
- The operator is responsible for the water quality used in the appliance.
- The operator is responsible for all routine inspections outlined in the Cleaning and Maintenance section of this manual.
- The operator is responsible for using and maintaining gas cylinders as specified by the RV manufacturer.
- The operator is responsible for ensuring that no spray water enters the appliance when cleaning the RV.
- The operator is responsible for using the appliance for potable water only. Additionally, they must ensure that non-potable water sources, components, or heating systems—whether new or old—are not connected in any way to the appliance.

While Driving

- The operator must ensure all components are seated and locked before moving the RV. Check the following:
 - - The access door is flush with the mounting plate.
 - - The door lock is engaged.



The operator is responsible for ensuring that the gas system is turned off at the gas cylinders before transit. Turn off all necessary valves as indicated by the RV manufacturer.

The operator is also responsible for ensuring that the appliance is off when refueling, traveling through tunnels, parking in garages or carports, or while on ferries.

About Your Product

Product Overview

RA65EH

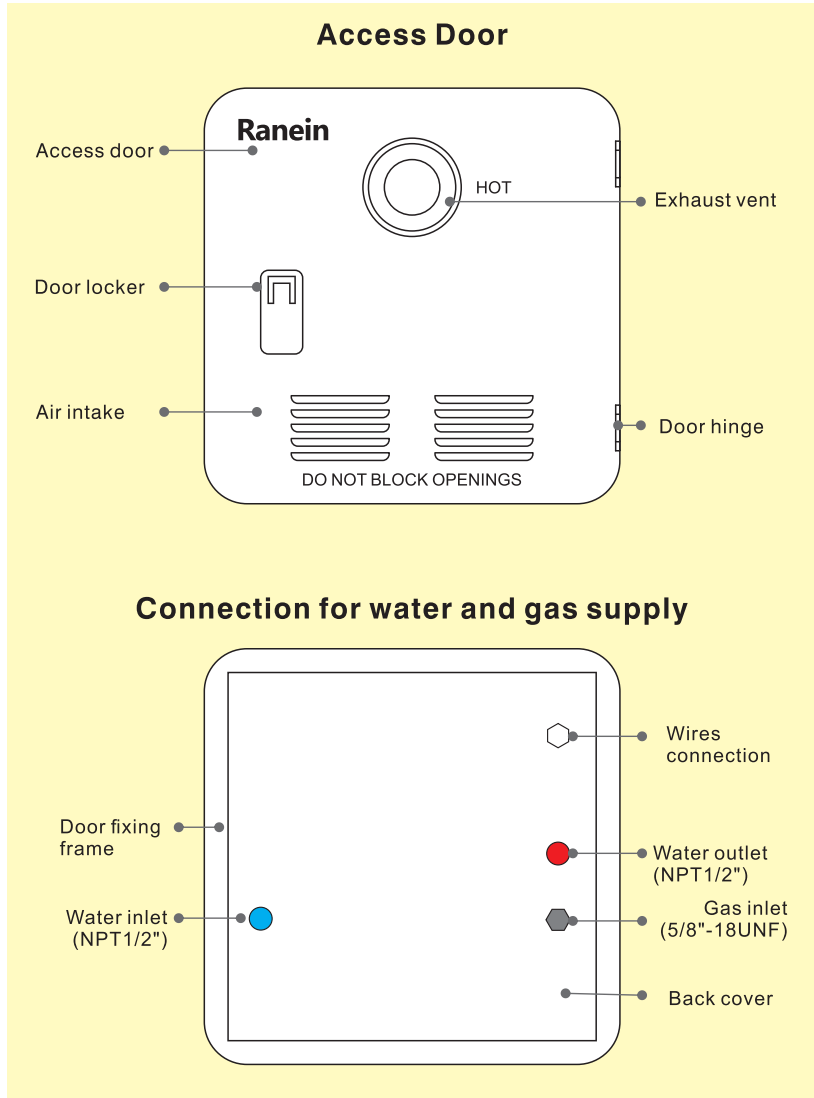

RA65LH/RA65SH

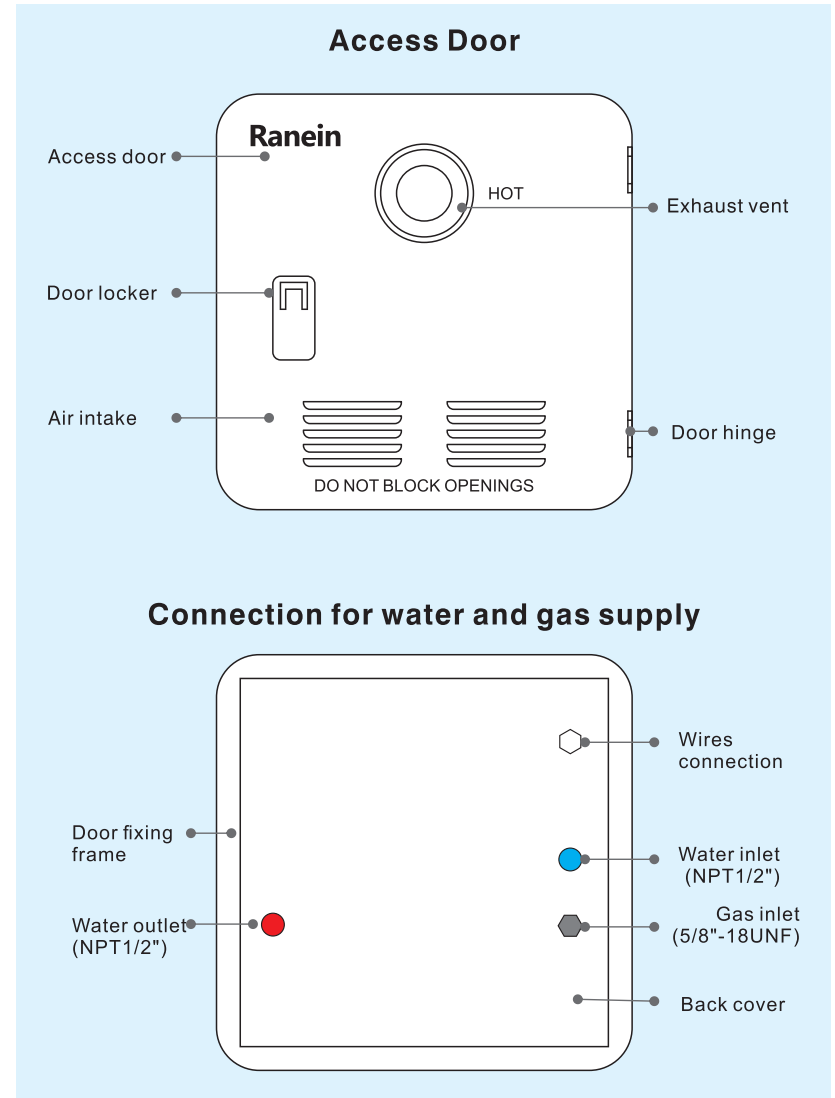

RA65ZH

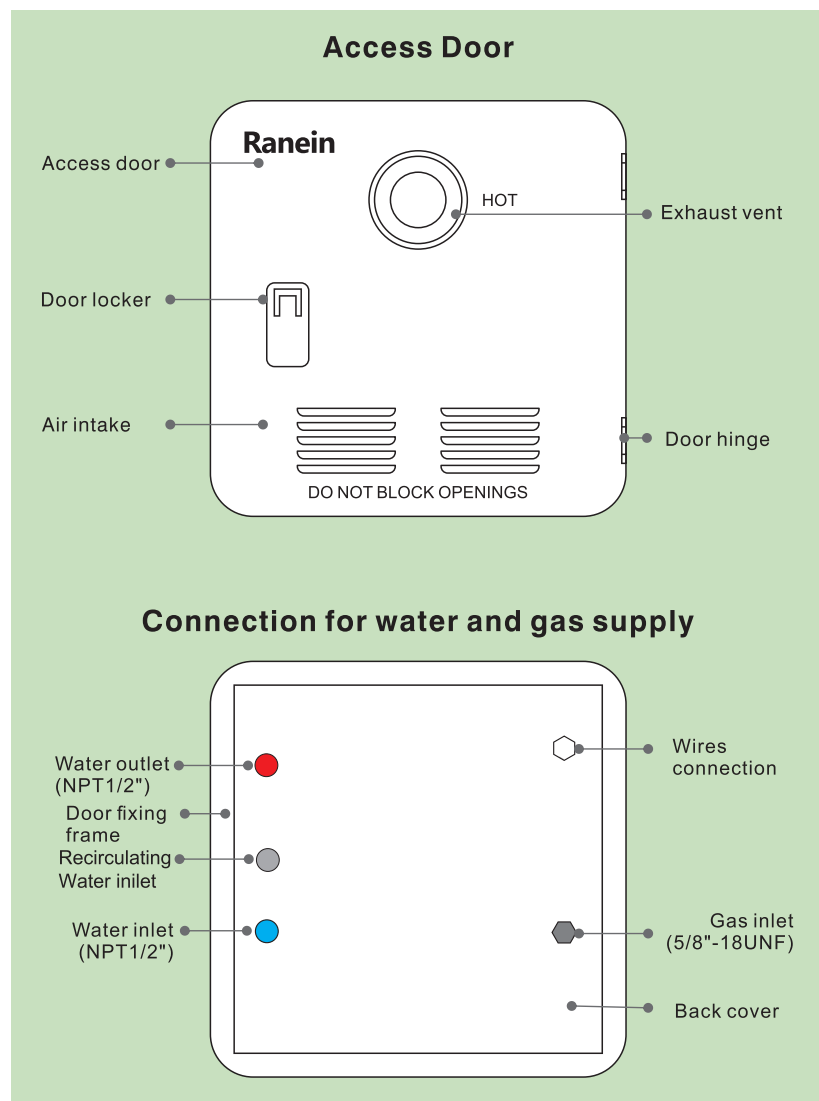

Product Features

The appliance is equipped with the following safety devices:

- **Flame Monitoring Device**
If the flame goes out, the device will automatically shut off the gas supply to the burner.
- **Anti-freeze Function**
The appliance is equipped with an anti-freeze device. When the outdoor temperature drops below freezing, the unit will automatically heat the water system to 32°F, after which it will stop. (Note: The power and gas supply must be turned on during the anti-freeze operation.)
- **Power Reverse Protection**
If the positive and negative connection cables are reversed, the unit will reduce its ability to protect the PCB.
- **Low-voltage/Over-voltage Shutdown**
The appliance will shut off if the voltage drops below 10V DC or rises above 17V DC.
- **Over-current Protection**
If a short circuit occurs in the appliance (greater than 10A), a fuse on the control unit is activated, and the appliance will shut off.
- **Hot Water Temperature Monitoring**
A water over-temperature switch prevents excessively high water temperatures in the event of an error.
- **Flue Fan Monitoring**
If the flue fan fails, the gas supply to the burner will be shut off.
- **Temperature Fluctuation Eliminator**
The appliance is equipped with a temperature fluctuation eliminator. For example, if the water flow suddenly decreases to a low flow rate (0.4 GPM), which could cause a significant rise in temperature, the fluctuation eliminator will regulate the temperature increase to prevent scalding injuries and ensure a comfortable bath.
- **Over-pressure Protection**
The appliance is equipped with a pressure relief valve that complies with the Relief Valves for Hot Water Supply Systems standard, ANSI Z21.22.

Basic Function

This appliance is designed exclusively for use in recreational vehicles. It connects to the vehicle's fresh water supply and hot water plumbing system.

Based on hot water demand, the tankless water heater heats incoming cold water to the desired output temperature by monitoring critical sensors to regulate the thermal energy released over a large heat exchanger. This creates a more efficient and energy-saving heating system compared to the conventional tank water heater, which wastes fuel during reheat cycles and is limited in volume output.

What's in the Box

Remove the product from the packaging and ensure the following items are included. If any item is damaged or missing, contact your Ranein dealer.

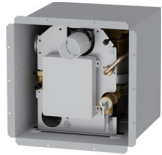

Main body x 1

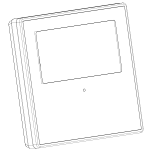

Wall controller x 1



Warranty card x 1



ST4.2x30 Screws
SUS430 ST4*30
(door fixing) x 14



ST4.2x20 Screws
(controller fixing) x 2



Wire connectors x 6



Use and care manual x 1

Product Specifications

Specifications		
BTU/HR (Nominal Input Rate)	65,000 BTU	
Hot Water Capacity (Gallon/min, @ Δ 45°F)	2.64	
Fuel Type	Propane (LP Gas)	
Fuel Inlet Pressure	10.5 in.wc-14 in. wc / 2620Pa-3490Pa	
Manifold Pressure	0.85 in.wc-6.4 in.wc / 210Pa-1600Pa	
Power Input	12V DC 5Amp	
Water Operating Pressure	10 PSI-65 PSI	
Burner Orifice (mm)	5 x Ø1.2	
Working Altitudes: 0-2000 ft (0-610 m)	Manifold Pressure (Pa)	1600
Product Dimensions (W x H x D)	12.6" x 12.5" x 14.74"	
Assembly (Body and Door) Dimensions (W x H x D)	Body with Door	15.2" x 15.1" x 15.4"
Installation Cutout and Depth Dimensions (W x H x D)	12.8" x 12.7" x 19.7"	
Shipping Weight (lbs/kg)	29.8/13.5	
Setting Temperature Range	95°F (35°C)-124°F (51°C)	

⚠ WARNING

Suffocation Hazard

Dispose of packaging material or keep it out of reach of small children. Failure to follow these instructions could result in serious injury or death.

Tools Required (Not Provided)

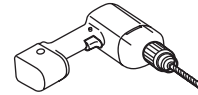

Electric drill
Bit size: 1/16"(3mm)
Note: It is use for holes drilling of exterior sheet metal of RV.



Gloves

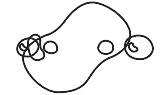

Soapy Water

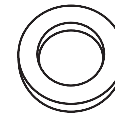

Washers



Butyl Tape

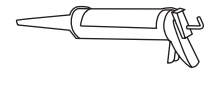

Sealant Gun

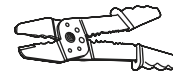

Wire Stripper Pliers



Adjustable Wrench x 2

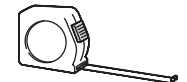

Tape Measure



Pencil



Phillips Screwdriver



Flat Blade



Cutting Knife



Eye Protection

Installation

⚠ DANGER

Observe all installation materials in accordance with governing codes and ordinances. Failure to follow these instructions could result in serious injury, property damage, or death.

General Installation Safety

⚠ WARNING



Electrical Shock and/or Fire Hazard

- Disconnect power before installation.
 - Turn off all gas to the supply system.
- Failure to do so can result in serious injury or death.

⚠ WARNING



Always wear protective gear, such as gloves, eyewear, and clothing, to avoid injuries during installation and servicing of the product.

For Recreational Vehicle (RV) Installation Only!

- A qualified person must perform any installation according to this instruction manual.
- **DO NOT** use test pressures higher than 40 in-wc (1.45 PSI) to test for gas leaks.
- **DO NOT** attempt to modify the appliance.
- **DO NOT** alter the appliance for use with a positive grounding battery system.
- **DO NOT** move the appliance by grabbing the interior components.
- Ensure all exhaust gases are directed outside the RV.
- Protect all combustible materials from exhaust gases.
- **DO NOT** draw air for combustion from occupied spaces.
- Always disconnect the 12V appliance to protect the control from surges that may occur when performing dielectric (hi-pot) testing, welding, electrical work, etc., on the coach.
- Only use a proven 12V power source, such as a battery or approved converter.
- **DO NOT** vent the water heater using a venting system that serves another appliance.
- **DO NOT** install directly into a shower or near direct heat.

Prepare Cutout Opening

1. Choose a location to place the appliance based on the following criteria:
 - **DO NOT** install on the rear or front of the RV to minimize contamination from road grime, debris, and wet roads when traveling.
 - **DO NOT** install the appliance in an outdoor enclosed area.

- **DO NOT** install the appliance in any location where the exhaust vent may be covered or obstructed when a swing door, baggage door, slide-out, pop-up, etc., is partially or fully extended.
- **DO NOT** install this appliance on any door or slide-out area.
- **DO NOT** install the appliance where the access door is less than:
 - 9" (229 mm) from any opening into the vehicle.
 - 36" (914 mm) from any motor-driven air intake.
 - 36" (914 mm) from any gas tank connection or ventilation.Refer to the RV edition for specific requirements.

Choose a convenient location where supply water, LP gas, and 12V DC are accessible to the backside of the appliance for installation and servicing.

The water heater is designed to be installed on a flat floor (made of wood or linoleum) or a fixed platform.

It is recommended that the appliance be located in a central location relative to the hot water loads.

Choose a location where clearances to combustible surfaces and the appliance are:

1" to the top surface.

0" to all other surfaces.

NOTE: To install on a carpeted area, a metal or wood panel that extends at least 3 inches beyond the width and depth of the water heater is required beneath the unit.

2. Create a cutout with the following dimensions A and B as shown in Fig. [reference].
- **NOTE:** The opening for the water heater should have right-angled corners.
3. Make sure that the front edge of the opening is surrounded by a solid frame to firmly anchor the water heater. Construct the space using a minimum of 1.5" x 1.5" wood or aluminum framing, if needed.

Existing Cutout

1. Determine the size of your existing cutout.

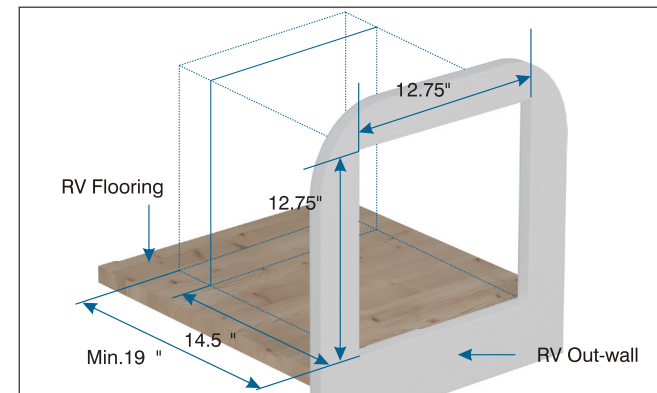

NOTE:

Fiberglass, film, and corrugated aluminum (Mesa 1") are all acceptable exterior wall siding solutions. The exterior wall opening must have exact dimensions with no radius corners.

4. Refer to depth "C" for minimum rear clearance for cabinets, appliances, and utility entry locations.

5. Ensure adequate spacing from other items on the RV wall to the door assembly.

6. Ensure a solid floor or platform with adequate weight-bearing capacity supports the appliance.

7. If necessary, create a platform to support the water heater. Some common solutions include: Ensure the platform is level from front to back and side to side after securing the RV.

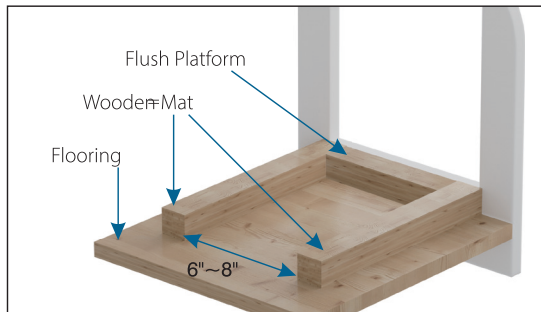
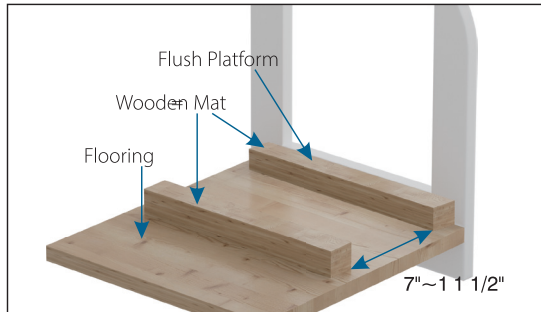
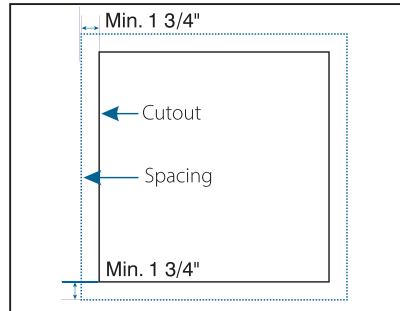

Prepare Utilities

Refer to the general connection diagram.

Gas Connection

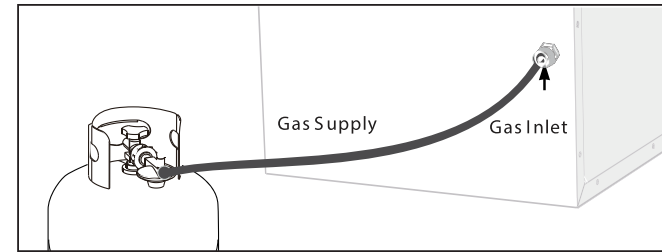

Electrical wiring

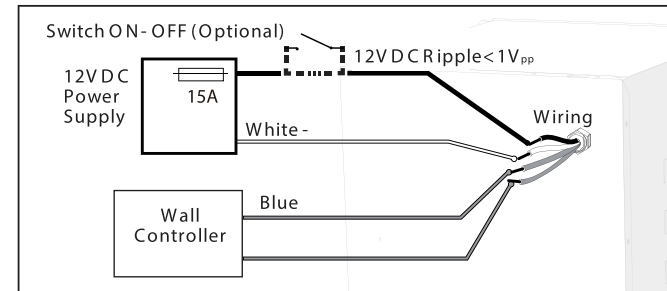

Water plumbing (RA65EH)

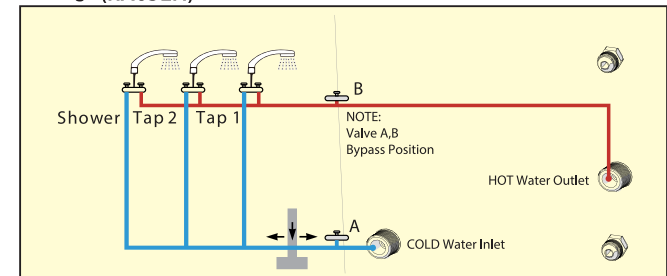

Water plumbing (RA65LH/RA65SH)

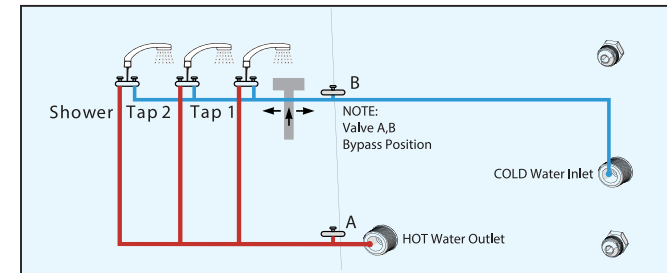

Water plumbing (RA65ZH)

Draining the water and cleaning the water inlet filter

1. Connect the waterway system according to the diagram requirements (please note if your waterway system has a mixing valve)

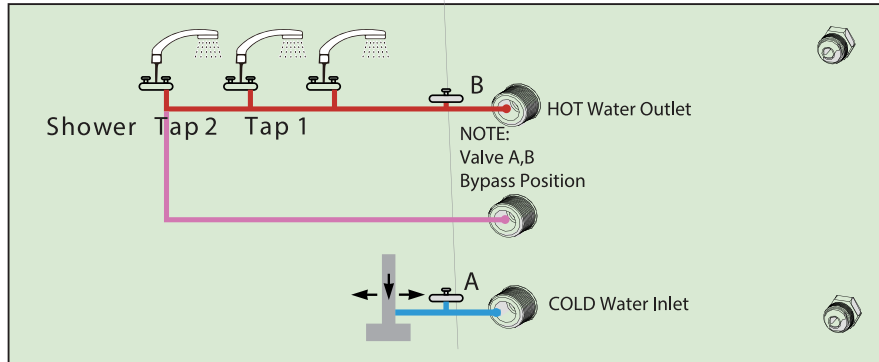

Installation diagram of mixing valve

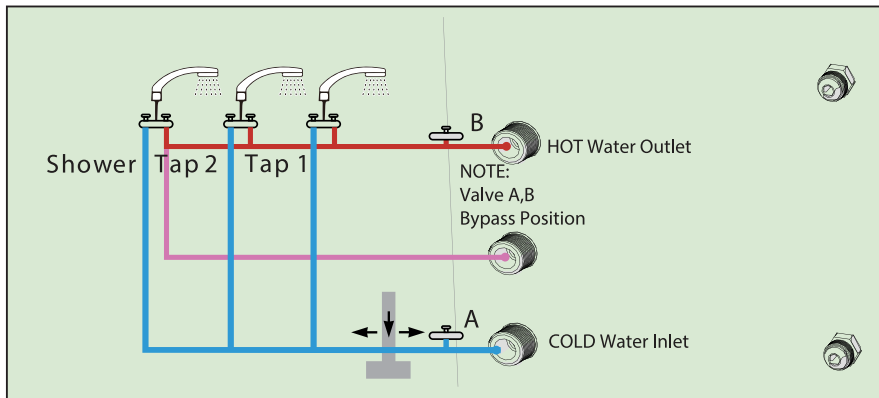

NOTE:

- The drawings are not intended to describe a complete system. The installer is responsible for determining the necessary components for a functional system.
- The drawings do not imply compliance with state or local code requirements or regulations. It is the installer's responsibility to ensure that the installation fully complies with all state or local code requirements or restrictions.
- **Optional:** The bypass valve can be installed to facilitate winterizing the coach. It is not required, as antifreeze can be used in the appliance. However, additional antifreeze (about 1L) is needed to fill the volume. Refer to the winterizing section of this manual for instructions.

Gas Plumbing

⚠ DANGER

Fire or Explosion Hazard

Follow all applicable codes, regulations, and instructions when performing service work. Failure to follow instructions can result in product damage, serious injury, or death.

- Fuel entering the appliance must be in the gas phase. The liquid phase must not be used, as it will damage the product.
- This appliance is rated for 65,000 BTU/HR, 11-14 in-wc (27.4-34.9 mbar). Follow NFPA 1192 and Z240 RV series for proper pipe sizing based on additional gas-burning appliance loads.
- Use LP gas (propane) only. Butane or any mixtures containing more than 10% butane must not be used.
- The gas line must terminate with a 5/8 UNF flared female compression fitting to connect with the rear gas connector of the appliance.
- A non-metallic flexible gas hose must be rated for 149°F (65°C). Anchor it appropriately to prevent fatigue and failure from worn edges.
- Make sure the operating pressure of the gas supply matches the appliance's operating pressure of 11-14 in-wc (27.4-34.9 mbar).

Locate the entry point for the plumbing to service the appliance's rear. Ensure the entry point is outside the footprint space of the appliance.

Feed the gas line into proximity, leaving enough length to flex into position so no kinks are created when connecting.

Note: An approved semi-flexible metallic pipe can be used as an extension from the gas line to the appliance.

Terminate the gas line with fittings to connect it to the appliance.

Electrical Wiring

⚠ DANGER

Electrical Shock Hazard

- Disconnect all power before performing any work.
- Always use a certified and proven 12V isolated power supply that is properly grounded to the RV.

Follow all applicable codes, regulations, and instruction materials when performing service work.

Failure to follow instructions could result in serious injury or death.

- Wiring connected to or near the appliance must be rated for 140°F (60°C) minimum.
 - Use only insulated terminals for all electrical connections.
 - The appliance requires a power source that adequately provides 10-17V DC to function correctly. Contact Ranein for available power centers, converters, and distribution panels.
1. Select a distribution branch greater than 3A, preferably 15A, to provide a nominal 12V to the appliance from the distribution panel.
 - **Note:** The appliance has a built-in 10A fuse, serviceable from the front of the product. The appliance can be on a dedicated or shared branch circuit with the same or higher rating.
 - **Optional:** A power switch can be placed in the living quarters for convenience, but it is not required as a button is located externally on the appliance. If the switch is fused, ensure it is rated for at least 3 amps.
 2. Locate the entry point for the wiring to service the rear of the appliance. Ensure the entry point is not in the footprint space of the appliance. Protect any edges to prevent wire abrasion.
 3. Determine the appropriate wire gauge (AWG) for the 12V power supply length. Ensure enough wire is available for the connection:
 - 16 AWG: max. 40 feet (12m)
 - 14 AWG: max. 66 feet (20m)
 4. Feed the wire from the power source to the entry point and make the connection to the power source.

Water Plumbing

- The plumbing must be rated to supply between 35–70 PSI nominal.
 - Connections can be made using PEX swivel nut adapters with NPT straight threads and a cone seal or standard ½" FPT fittings.
 - This water heater requires a minimum water flow of 0.32 Gallons per Minute (GPM) for proper operation.
1. Locate the entry point for the plumbing to service the appliance's rear. Ensure the entry point is not in the footprint space of the appliance.
 2. Create a piping layout to supply the appliance and all faucets.
 - **Note:** Dry-fit tubing and fittings before clamping them together. Adjust sections to avoid excessive stress on the fittings when assembled to the appliance. It may be helpful to fit the device into position to determine the appropriate piping layout.
 3. Clamp and seal all fittings together. Terminate the piping with the appropriate fittings.

Prepare Wall Control

1. Determine a location to install the wall controller inside the RV.
2. Drill a ¾" hole and clean the edges.
3. If necessary, run two electrical wires to extend the wall control connections (blue cables) to the appliance connections (blue wires), using the appropriate wire size: 16 AWG max. 65 ft (20 m).

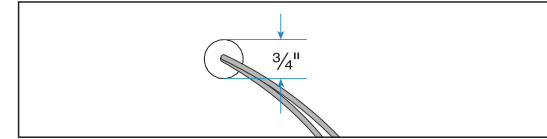

Fittings for water inlet and outlet

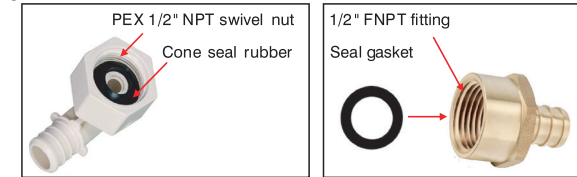

Prepare Water Heater

1. Remove the water heater from its packaging by grasping the metal sides of the housing and lifting upward until it is completely removed from the box.
2. Remove the protective caps from the COLD, HOT water connectors, and GAS connector at the back of the unit.

RA65EH

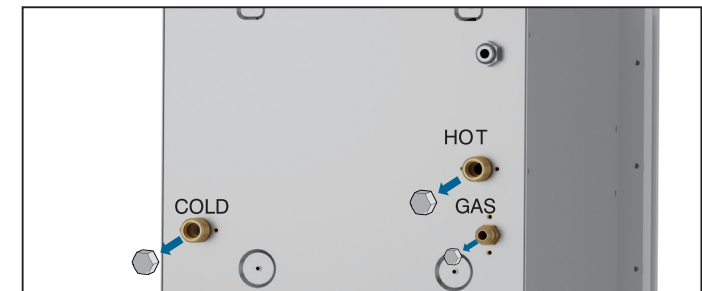

RA65LH/
RA65SH

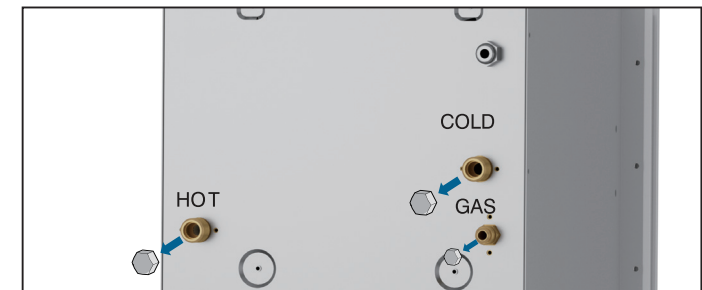

RA65ZH

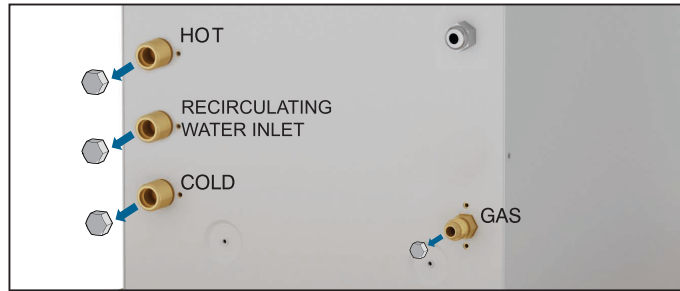

Water Heater Installation

Prepare Water Heater

1. Apply adequate water sealing material, such as butyl tape (recommended width: 1", not provided), around the entire backside flange area and holes.

NOTE: Do not use adhesive sealing materials, such as silicone, for the watertight seal.

2. Carefully position the water heater into the frame opening, ensuring the flange is evenly spaced from the exterior wall of the RV.

NOTE: Make sure the area beneath and behind the appliance is clean and free from debris or obstructions. Gently slide the device across the floor to prevent damage to linoleum.

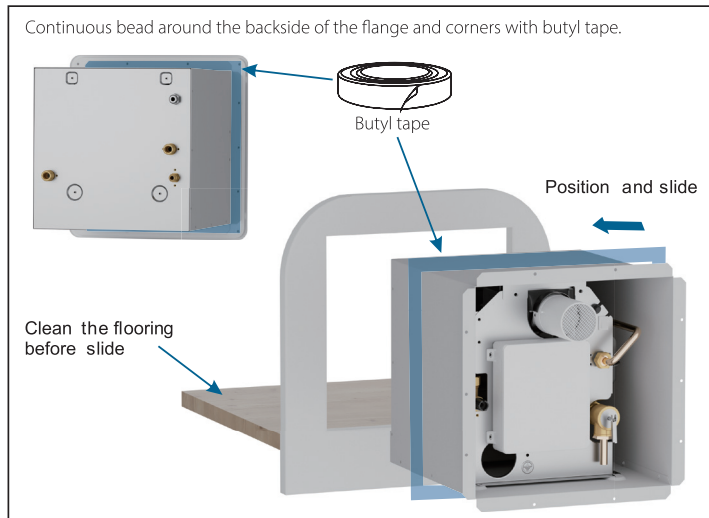

Check the sealing between the backside flange and the out wall. Make sure the flange touches the RV's out wall.

NOTE:

It will cause leakage if there are gaps between the flange and out wall.

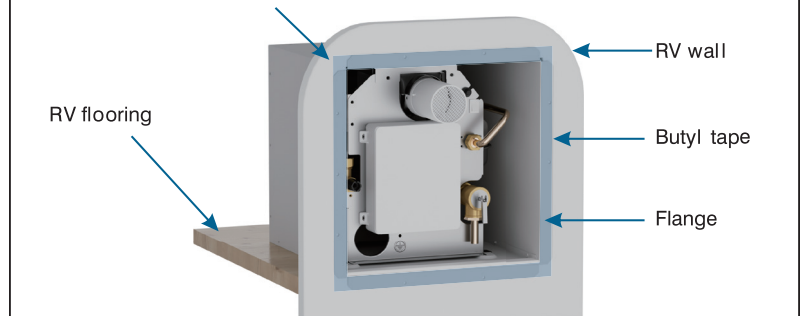

Water Pipe / Gas Connection

Connect the water pipe or gas service line to the water pipe or gas-flared fitting on the back of the appliance. Use two wrenches to tighten the compression fitting, ensuring it is secure without overtightening to avoid damage to the unit.

NOTE: Do not use sealing tape or compound on the compression-type fitting.

1. Use two wrenches to tighten the gas connectors.
2. Use one wrench to tighten the water connectors.

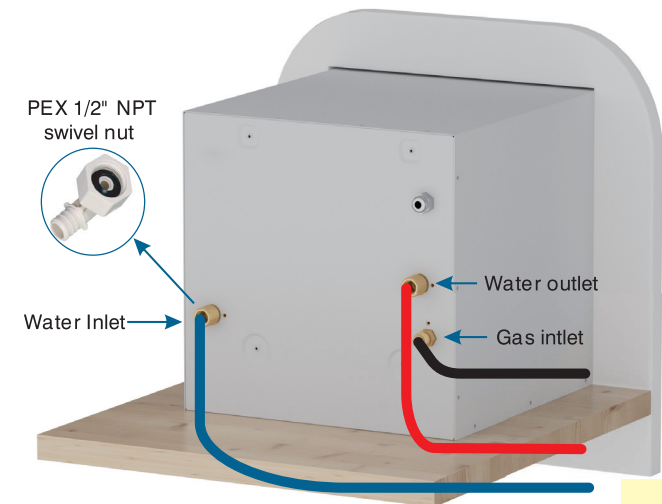

RA65EH

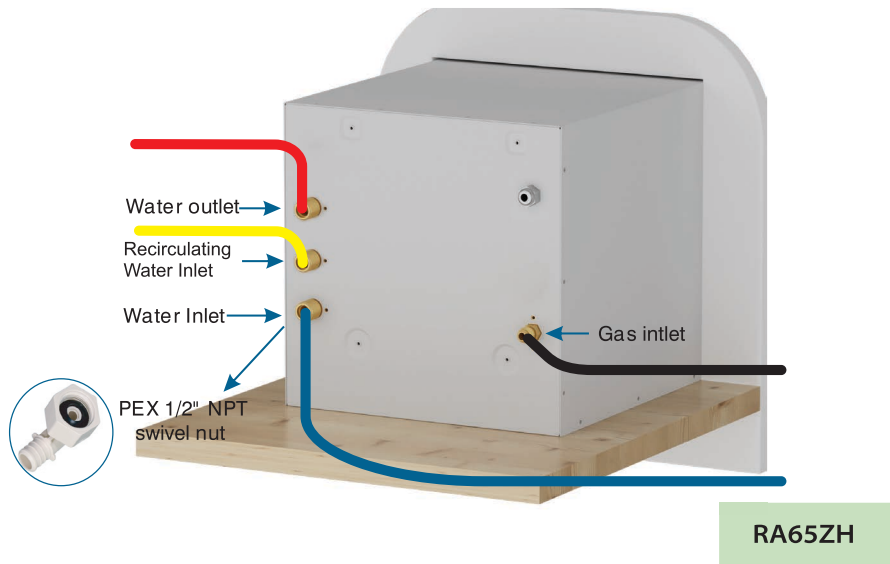
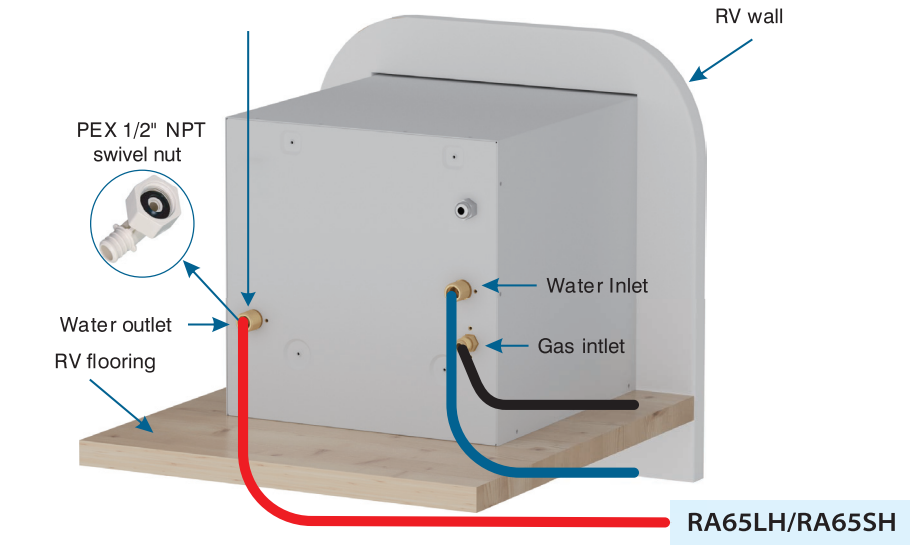

NOTE : Do not use sealing tape or compound on the compression-type fitting.

Electrical Connection

1. Set the power switch for the water heater to the "OFF" position.
2. Connect the power supply wires (located on the rear of the water heater — white and black wires) to the appropriate 12V DC power source connection

Note: The black wire is positive (+), and the white wire is negative (-).

3. Connect the wall controller wires (the two blue wires on the appliance).

Note: Polarity does not matter; the wires can be connected to either of the blue cables.

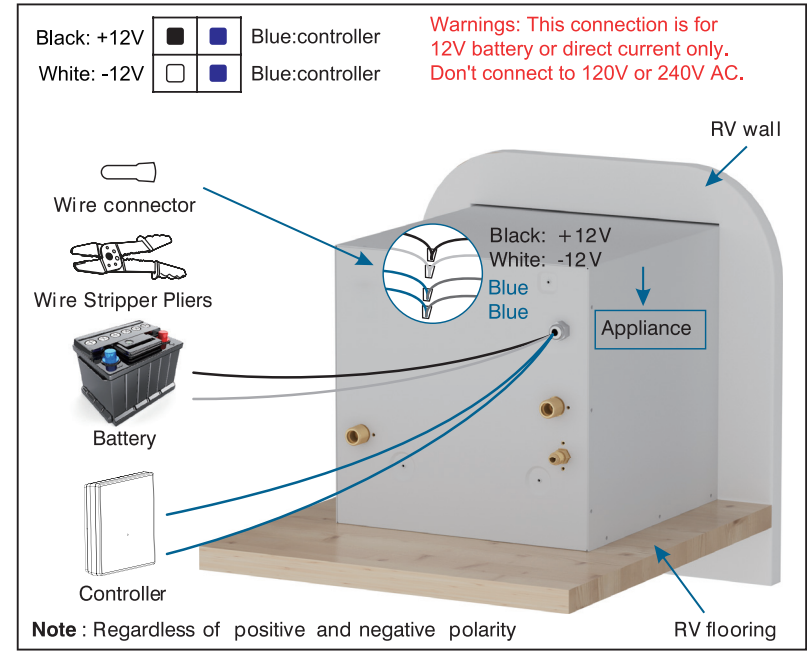

Note : Regardless of positive and negative polarity

Drill 14 holes on the metal board of the RV out the wall with a 1/8"(3mm) bit.
Note: Drill the metal board only—no need to drill the inner wooden or heat insulation layer.

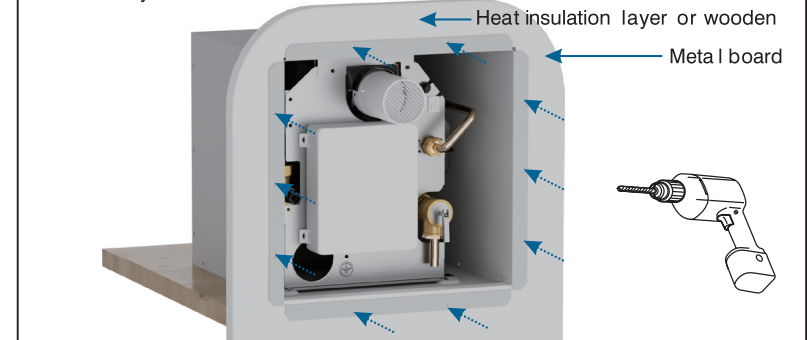

Door Frame Installation

1. Unpack the door assembly from the package.
2. Lift the handle of the door lock with your finger.
3. Rotate the handle 90 degrees.
4. Open the door.

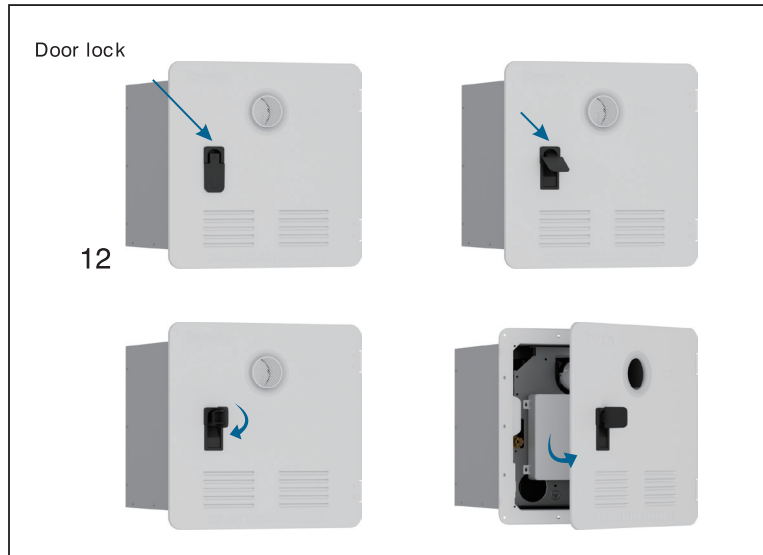

Securing the Water Heater

1. Insert the door flange into the water heater housing and press the flange firmly against the sidewall.

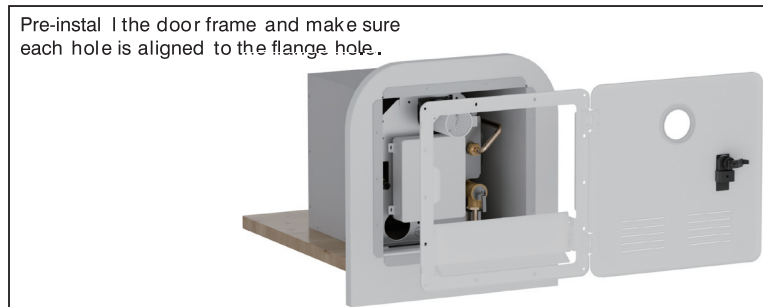

2. Secure the flange to the vehicle using 12-#8 (min 1") pan head screws (not provided) through each hole along the perimeter. Verify that a tight seal exists between the sidewall and the flange.

Note: Ensure the butyl tape forms a tight seal between the RV siding and appliance flange. If gaps exist, remove the appliance and apply a double layer of butyl tape.

Fixing door frame with ST3.9*30mm self screws(14Pcs).

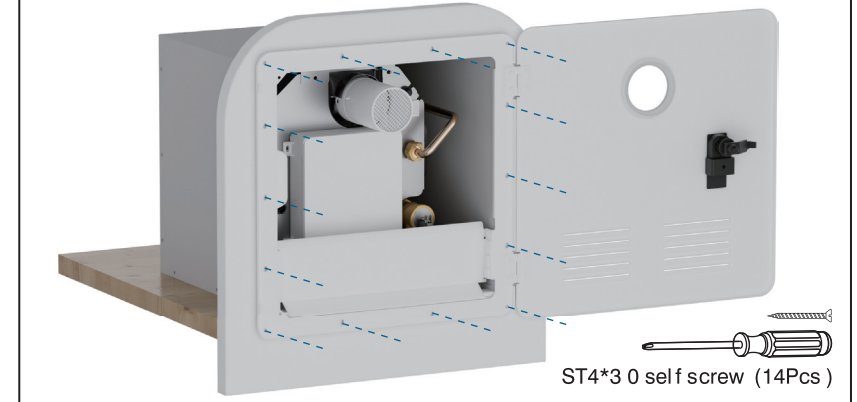

3. Apply a liberal amount of sealant around the door frame to fill any gaps in the RV wall. Wipe away any excess adhesive.

Apply sealing material at the adage of the door frame (for better waterproofing). Remove excess sealing material after sealing.

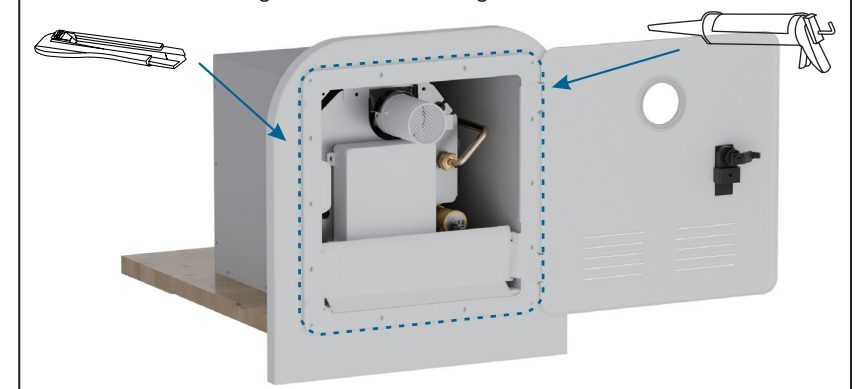

Wall Controller Installation

1. Disassemble the wall controller.
 - a) Press and push up the buckle of the wall controller.
 - b) Open the cover with a finger or a flat blade.

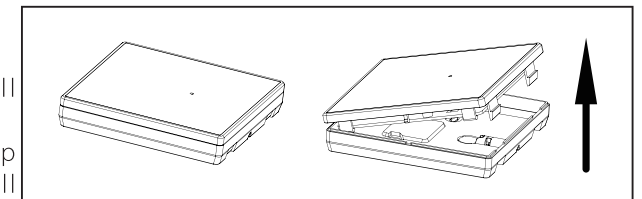

2. Install the back cover of the wall controller.

a) Install the back cover of the wall controller over the 3/4" hole. Fix the back cover to the wall using 2-ST3.9*20 screws.

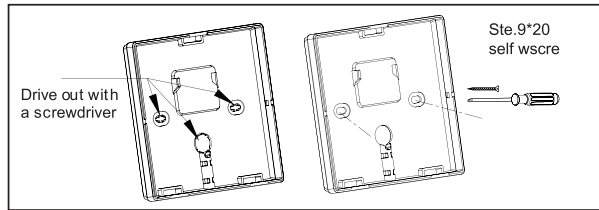

3. Assemble the controller cover.
a) Reassemble the cover after fixing the back cover in place.

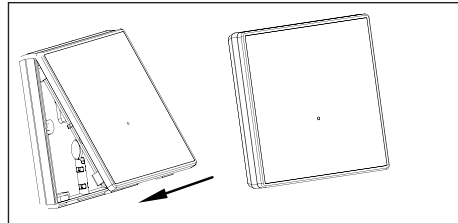

4. Fix the installation board to the wall with 2-ST3.9 screws. (If you prefer not to disassemble the controller cover.)

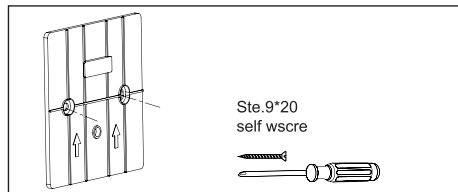

5. Clip the monitor into the installation board.

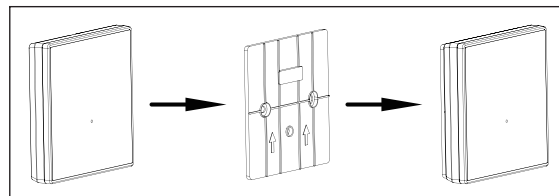

Ball valve switch status (Compatible with model RA65SH/RA65ZH)

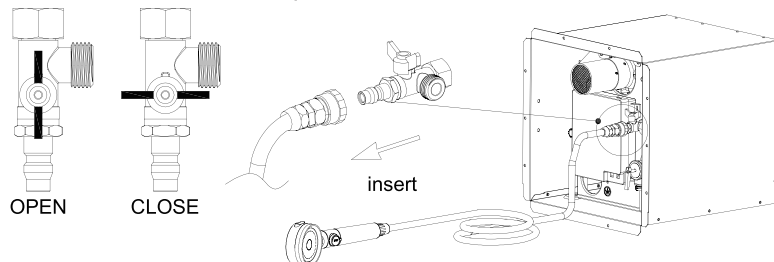

Before using the quick-connect shower, please ensure that the ball valve is closed. After connecting the shower, open the ball valve. Hot water may flow out during the operation of the appliance. Please monitor the water temperature to avoid burns.

Wiring Diagram

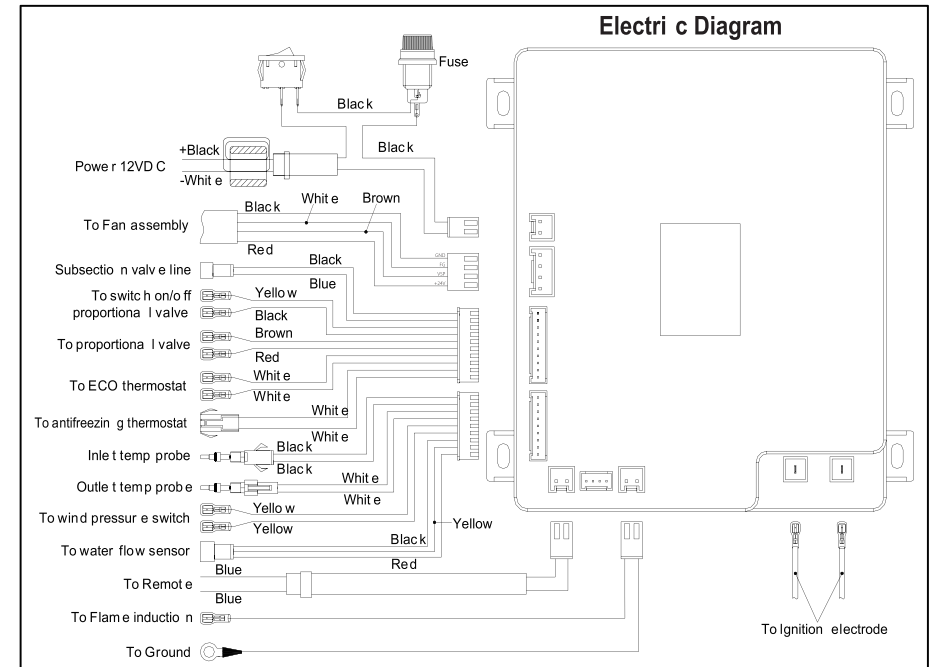

Check After

Checking for gas leak

⚠ WARNING

Risk of Death and Personal Injury from Fire and Explosion!

- **DO NOT** use matches, candles, or any other ignition sources when checking for gas leaks.
- After connecting the gas supply, check for gas leaks at all gas connections using a gas leak detection liquid or equivalent. Ensure the test pressure is below 40 in. wc (100 kPa).
- Be sure to re-test all fittings after making adjustments to any loose connections.
- Failure to follow these instructions may result in serious injury, property damage, or death.

1. Turn on the gas supply or alternative pressure supply.
2. Check the appliance and all gas connections for leaks using a leak detection liquid (not provided) or an equivalent gas leak detection method. Bubbles indicate a gas leak, which must be repaired.
3. Repair any gas leaks as needed.
4. Repeat the gas leak check after making any adjustments to

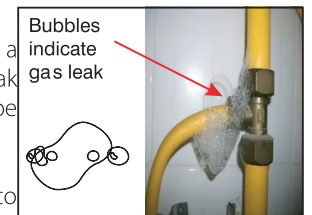

loose connections.

- Note: After leak checking, ensure the gas supply pressure corresponds to the operating pressure of the appliance (10.5–14 in. WC or 2620 Pa–3490 Pa).

Checking for Water Leaks

- Ensure the power switch on the water heater is in the "OFF" position.
- Turn on the water supply to the appliance.
- Open the water faucets to fill the system with water. Close the taps once the water flows smoothly and all air is removed from the lines.
- Visually inspect and feel all connections for water leaks.
- Repair any water leaks as needed.
- Repeat the water leak check after making any adjustments to loose connections.

Functional Test

⚠ WARNING

Fire or Explosion Hazard

- Ensure all required system leak tests are completed before performing any functional tests.
- Failure to follow these instructions could result in serious injury, property damage, or death.

Preparation:

- Verify that the power switch is in the "OFF" position.
- Confirm that there is a steady water flow (not pulsating) and no air in the system. If you hear pounding, adjust the water pump settings.
- Ensure that all valves controlling the mix of cold and hot water are closed.
- Note:** Outside faucets with detachable spigots and showerheads with flow interrupters can cause hot water to bleed into the cold side if the valves aren't properly closed. This can affect the performance of the water heater.

Starting Work:

- Turn the power switch to the "ON" position on the appliance and check that the wall controller is illuminated. If it isn't, press the button on the wall controller to turn it on. The controller display will show the current water temperature.
- Note:** The default factory setting is 108°F (42°C).
- Turn on the gas supply.
- Open a hot water faucet and check that the unit ignites and supplies hot water.
- The wall controller display will show the current temperature.
- Note:** If error codes or performance issues occur, refer to the troubleshooting section of this manual.

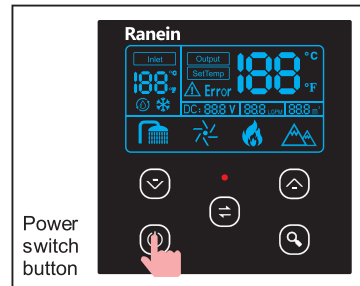
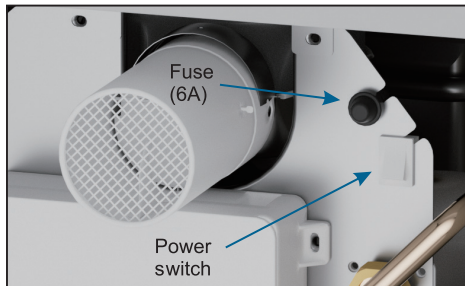

Operation Instruction

Controller Operation

Before regular operation of the appliance, perform a basic functional test each time the RV and water system are set up for use. (Ensure that the electric, water, and gas supplies are standard.)

- Touch the button to turn on the power. The display will show the current temperature setting.
- The touch button allows you to switch the temperature display between °F and °C. Please refer to the picture below.
- Touch the button to adjust the temperature to your desired setting. The wall controller settings range from 95°F (35°C) to 124°F (51°C). The default temperature setting from the factory is 108°F (42°C).

RA65EH

RA65LH

RA65SH

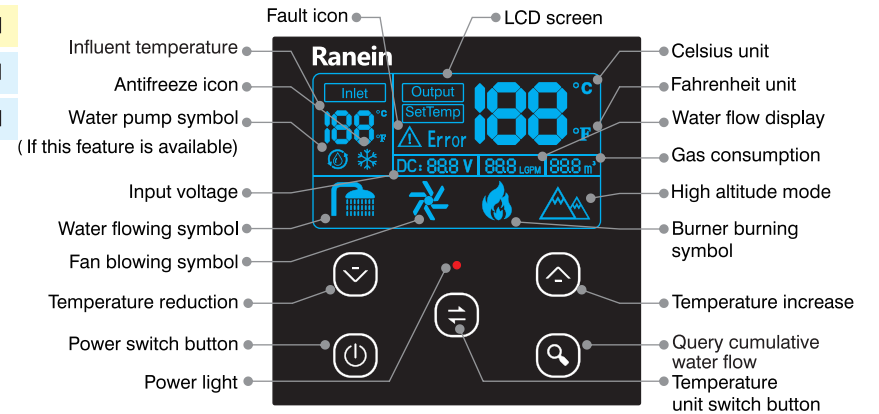

Plains model

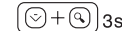

3s

Wait 30 s

High-altitude mode

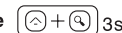

3s

*Operate the machine while it is running.

RA65ZH

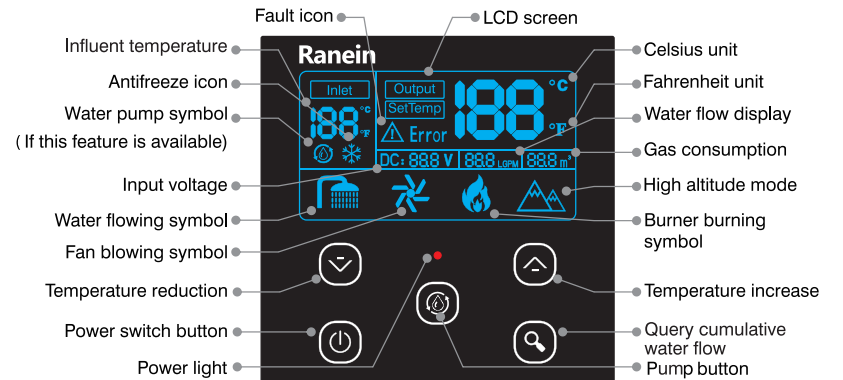

Controller Operation

Before normal operation of the appliance, perform a basic functional test each time the RV and water system are set up for use. The appliance can be operated from the wall controller, which includes the power switch. The control switch can be used for the "ON/OFF" function.

1. Touch the button marked "Ⓞ" to turn the power on/off. The "188" on the panel will be illuminated and display the current temperature setting.
2. Touch the button marked "°F/°C" to switch the temperature display between °F and °C. The corresponding LED will light up on the controller.
3. Touch the "Ⓢ" or "Ⓣ" button to adjust the temperature to your desired setting. The wall controller settings range from 95°F (35°C) to 124°F (51°C).
4. Touch the button marked "Ⓞ" to put the RV water heater into shutdown mode. If not in use for an extended period, press the "OFF" switch to turn off the power.

Methods for use:

1. Method 1: Point-of-use mixing: Set the controller temperature to the desired output temperature, typically elevated above comfortable bathing temperatures (e.g., 115°F / 46°C). Turn the hot water on, and once hot, add cold water to achieve the desired temperature.
2. Method 2: Single-point use: Set the controller temperature to the desired output temperature for the faucet you want to use, typically set to the desired bathing temperature. The unit will maintain the set temperature by using only the hot water faucet, with no need to mix cold water.

Zero-cold-water function:

1. Click the "Ⓞ" once, the water pump icon will remain on, and a cycle of heating will be completed. After the cycle of heating is finished, the preheating state will be exited.
2. Click the "Ⓢ" once to wake up the water pump, and the icon will remain on. At this time, long-press the "Ⓢ" for three seconds. Then the zero -cold-water button will flash three times and then remain on (accompanied by three beeps), and a cycle of heating will be completed. After the cycle of heating is completed , it will enter the standby state , and the water pump will start by default for the next startup.

Safe Operation

⚠ WARNING

Scald Hazard

- Never allow infants, children, or the elderly to adjust the water temperature, and never leave them unsupervised when using hot water.

Failure to follow these instructions may result in serious injury.

Consider the following points for the safe use of the appliance:

1. First, install an RV water regulator at the inlet of the coach, and operate within a water pressure range of 35–70 PSI.
2. The factory default water temperature setting is 108°F (42°C).
3. There may be variations between the temperature delivered from the appliance and the temperature at the faucet due to factors such as seasonal water conditions (e.g., hot summer) or the length of pipe from the appliance.
4. Always check the water temperature, using the display and by hand-touching, before bathing or using hot water for any other purposes. Refer to the chart below for temperature guidelines.

Temperature °F (°C)	Time before skin becomes scalded
155 (68)	1 Second
148 (64)	2 Seconds
140 (60)	5 Seconds
133 (56)	15 Seconds
127 (52)	1 Minute
124 (51)	3 Minutes
120 (48)	5 Minutes
100 (37)	Safe Bathing Temperature

Source: Moritz, A.R. / Hერიques, F.C.: Studies of thermal injuries: the relative importance of time and surface temperature in causation of cutaneous burns A. J. Pathol 1947; 23: 695 - 720.

For High Altitude Use

This appliance can be used at high altitudes and has been tested up to 2,000 feet.

For prolonged use at higher altitudes, please contact service@ranein.net.

⚠ WARNING

Burn or Scald Hazard

- Never perform any work while the water heater is operating.
- Always turn off the electrical and LP gas supply before performing any work.
- Never perform work when the appliance is hot.
- Do not actuate the pressure relief valve while the appliance is hot.
- Do not actuate the drain plug if the appliance is under water pressure and/or still hot.

⚠ CAUTION

Sharp Edges Can Cause Cuts and Injury

- Always wear protective gear, such as gloves, to avoid injuries from sharp edges during installation or while handling the appliance.

Winterizing Operation

Winterizing the Water Heater

⚠ CAUTION

Product Damage Due to Frost Conditions ❄

In frost conditions, when ambient temperatures are below 39°F (4°C), there is a risk that water in pipes, faucets, and appliances could freeze. This can cause significant damage to the system.

Automatic Winterizing

The appliance is equipped with an automatic antifreeze device. When the water temperature drops to 43°F (6°C), the appliance will activate. It will continue to operate until the water temperature reaches 90°F (32°C), at which point the appliance will stop. This process operates in a continuous cycle.

Consider the Following Points for the Safe Use of the Appliance

Note: The appliance's electric and gas supply must be turned on for normal operation, and the controller can be set to standby mode. If the electric and gas supply is not provided, the automatic winterizing device will not function.

Manual Winterizing Operation

To winterize the appliance for long-term storage, you must drain all water from the system. To do this, follow the steps below:

Winterizing the RV by Draining Water:

1. Close valves A and B, open valve C at the back of the appliance.

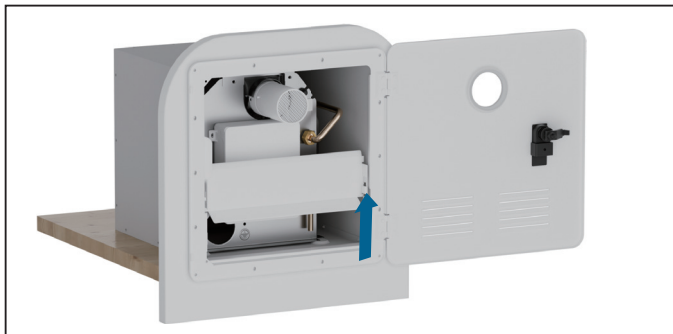
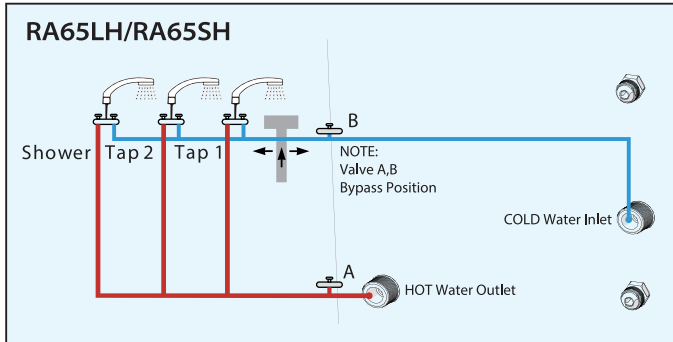
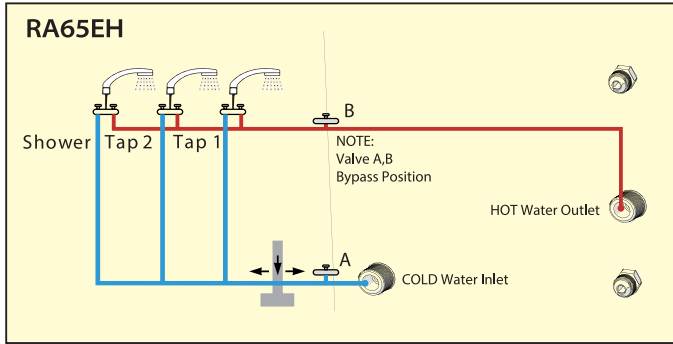

2. Open the door and pull out the baffle from the door frame.

3. Open the safety valve by hand and allow the water to drain completely from the unit. Unscrew the water inlet filter and clean it thoroughly.

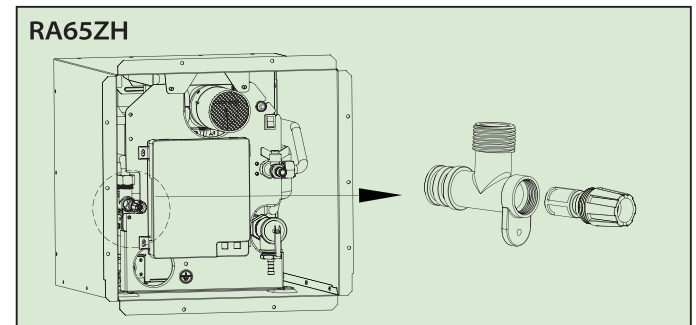
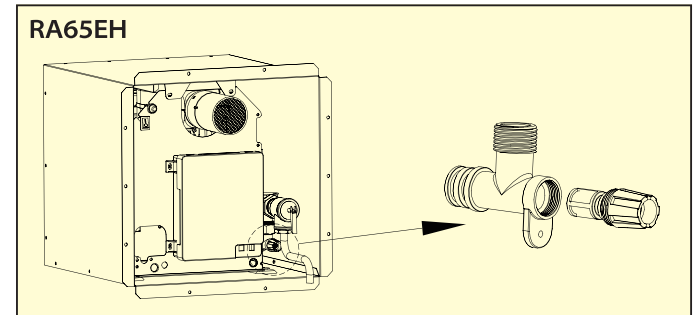
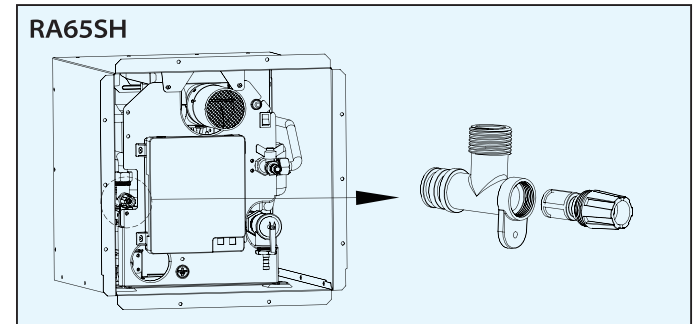
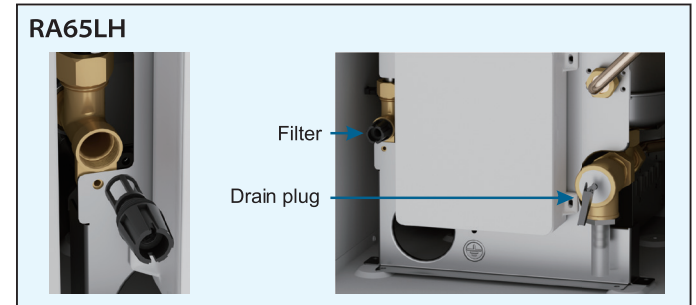

4. Ensure the water in the appliance has completely drained. Then, screw the drain plug and the filter back in place.

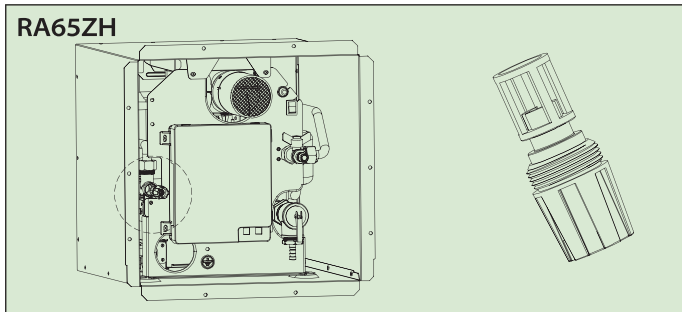
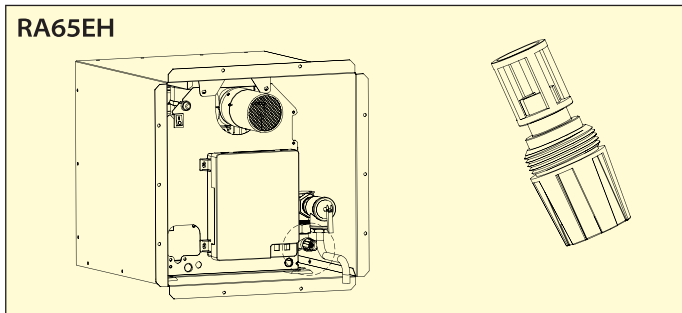
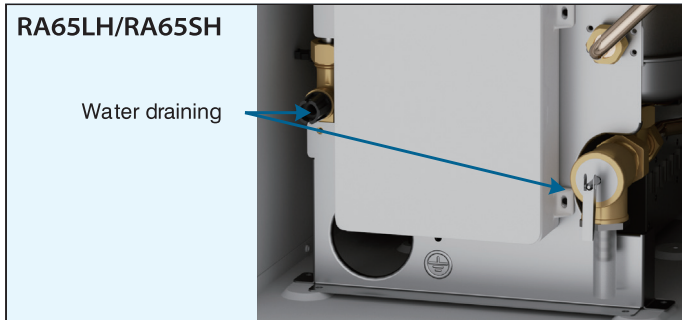

5. Flush the RV's water system with a suitable winterizing fluid, following the supplier's or RV manufacturer's guidelines.

Note: The appliance is protected against freezing conditions once the water has been fully drained.

Winterizing the RV with Winterizing Fluid

- Winterizing the RV with a winterizing fluid is only possible if a bypass kit is installed (note: this kit is not included in the scope of delivery).
- Follow the instructions provided by the RV coach manufacturer for winterizing the water system.
- Supplement the following important water heater instructions when completing any winterizing steps:

Compressed Air Pressure for Blowing Out the Water Heater

- **DO NOT** exceed 30 PSI when using compressed air in the water heater.
- During the blowout process for the entire water system, isolate the water heater by closing all drain plugs and faucets. Only open the water heater drain plug and filter cover to ensure maximum pressure and flow are directed through the water heater for complete evacuation.

Antifreeze

- Use a non-toxic antifreeze recommended by the RV coach manufacturer.
- Antifreeze can be used directly in the water heater. Plan for an additional 1L to fill the system.

Optional

- A bypass valve can be installed or used to bypass filling the water heater with antifreeze. Before bypassing, the water heater must be evacuated with compressed air (see steps above).

Storage and Transit

When the RV is not intended for use, it is considered to be in storage or transit. To prepare the water heater, follow the steps below: 1. Turn off the gas supply. 2. Turn off the water heater main switch. 3. Drain the water from the system and water heater by removing the filter cover and drain plug. If freezing conditions are possible, winterize the system according to the "Winterizing Water Heater" guidelines (refer to the above operation).

For Next Season's Use

- Thoroughly flush the water heater and system with clean drinking water through both the hot and cold sides before using. Drain the water several times through the water heater drain plug. Sanitize the water system according to the recommendations of your coach manufacturer.

Routine Inspection

Routine inspection is critical for maintaining the proper operation of your appliance. Unless otherwise specified, review the following items annually or before each season:

1. Inspect the gas system, water system, and installation every two years or as otherwise specified by your RV coach manufacturer, and have this inspection performed by a qualified person.
2. Inspect for cracks, separation, and peeling of seals around the RV wall. Remove and re-seal as necessary (using caulking or tape) between the side wall and the water heater door. Ensure that the unit is securely mounted to the vehicle.

3. Before using your vehicle, pre-inspect the air intake openings (louvers) to ensure they are completely open and clear of any debris, including mud, leaves, twigs, insects, etc. Remove all obstructions to allow for unrestricted airflow.
4. Before using the vehicle, open the door and verify that no debris or combustible materials are present, especially in the area around the burner and gas controls. Remove any items and clean the bottom of the housing.
5. Before actively using the vehicle, verify that the exhaust tube and screen are completely clear of obstructions, including mud, leaves, twigs, insects, nests, etc. Clean by gently loosening the debris and using a vacuum to clear it. Use only water, applying it gently from a spray bottle. Never spray directly with high-pressure water. Next, run the appliance to dry any moisture and blow out loose debris.
Note: Using any aftermarket protective screen is prohibited and will void the warranty.
6. Inspect the interior surface of the housing for any cracks or corroded areas that could allow gases to penetrate into or out of the vehicle's interior. Pay special attention to areas around the hot water, cold water, gas, and electrical connections.
Note: If any damage is found, please contact a technician for repairs or reach out to Ranein customer service.
7. Check that all wire connections are securely in place and that there are no signs of chafing or cracks in the insulation. Verify that the spark ignition cable between the control board and the igniter is securely connected and not in contact with any metal components.
8. Inspect the pressure safety valve to ensure it has not been leaking (no water residue). Refer to the "Pressure Safety Valve Maintenance" section for further inspection.
9. Inspect, clean, or replace the water inlet filter as necessary. Use a brush to clean the filter.

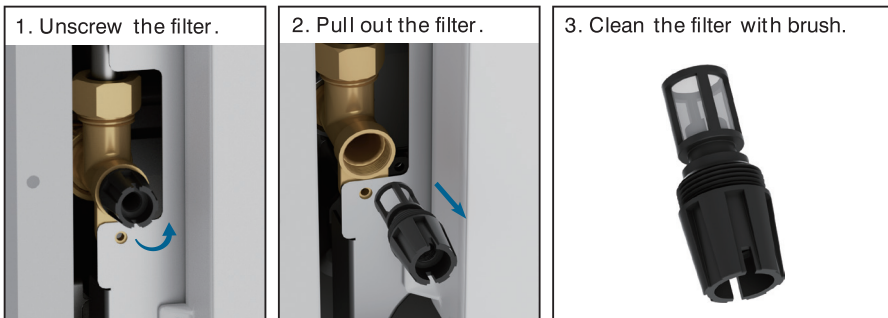

⚠ WARNING

Burn or Scald Hazard

- Never actuate the pressure relief valve while the appliance is in operation.
- Never tamper with the pressure relief valve.

Pressure Safety Valve Maintenance

1. The unit is equipped with a water pressure safety valve. This valve must be tested once a year to ensure the safety device is functioning properly.
2. The pressure relief valve is a safety component and should never be removed, except for replacement.

Note: A certified service technician must replace the pressure relief valve if it is defective.

3. Tampering with the pressure relief valve will void the warranty.
4. Lift the pressure safety valve handle upward and check for any water dripping from the valve.

Hard Water and Decalcification

When exposed to higher concentrations of hard water over prolonged use, it is advised to install a proper water treatment device for the incoming water to the coach.

Hard water may cause a reduction in the appliance's performance over time.

Contact Ranein for decalcification instructions.

Recommended decalcification frequency per year:

Water hardness mg/l CaCO ₃	Very hard : > 180	1	2	4
	Hard : 121-180	1	1	3
	Moderately hard : 61-120	1	1	2
	Soft : 0-60	1	1	1
Use *		low	normal	high

Troubleshooting

Error Code

If the appliance malfunctions, a beep alarm will sound, and the error code will appear on the wall controller. Write down the code, then try resolving the issue by stopping and restarting the water flow several times or resetting the appliance as follows:

Switch the power switch in front of the water heater to the "OFF" position (ensure the water valve and shower are open).

- Wait for 5 seconds.
- Switch the appliance back on.
- Continue using the appliance as usual. However, if the error codes persist, refer to the following table for potential causes.

Error Code	Possible cause	Solution
Eu: Under-voltage and over-voltage protection	Undervoltage: voltage drops to $9.5 \pm 0.1V$ and then rises to $10 \pm 0.1V$; Overvoltage: the voltage rises to $17.3 \pm 0.1V$ and then falls to $16.7 \pm 0.1V$	Check the vehicle voltage and exclude unstable voltage.
En: Timing time is up	Set the end of a device runtime	Rebooting the device

Error Code	Possible cause	Solution
E1: Flame sense fault	Insufficient fuel supply to start operation.	Confirm all gas valves are open and restart the appliance 4-5 times (First time for using).
		Confirm adequate fuel in tanks.
	Low gas inlet pressure.	Check regulator for operation, replace if needed.
E2: Detected fake flame signal	Flame sensor or system failure.	If the flame sensor induction or PCB board is broken, it need to be replaced by one of them.
		PCB primary control board failure or program faulty. Replace the main control board.
E3: Over temperature mechanical sensor fault	Thermostator system fault.	When the E3 error displays, let cold water flow 10-20S then restart the appliance. If E3 still displays, check the water flow if too low. If not, check the thermostat to see if broken.
E4: Water inlet temperature sensor fault	Temperature sensor or system failure.	Check the water outlet temperature wires connection; if loosened, tighten it. If not, maybe the outlet temperature sensor fails. Replace it.
E5: Air pressure fault	Exhaust Blockage.	Remove obstruction, then restart the appliance.
	High winds blowing on exhaust.	Move or re-orient the coach exhaust is not facing high winds, then restart the appliance.
	Air switchorfan Fault.	Check the air switch or fan if broken.
E6: Temperature Surge alarm	Cold water surge in system.	Reduce toilet flushes and the number of cold water faucets opened during operation.
	Cold water mix ratio.	Reduce temperature setting to reduce cold water mix ratio.
		Check for shower head and outdoor faucet valves leaking cold water to the hot side.
	Insufficient water supply.	Confirm water tank is full or city water valve is fully open.
		Air in the water lines-continue to run all faucets, hot and cold, open until the air purged.
	Insufficient water flow.	Filter plugged- review "Cleaning and Maintenance" section of this manual.
Low flow faucets - check that the minimum flow is 0.32gpm.		
Temperature sensor or systemfault.	Replace the outlet temperature or main PCB control board.	
E7: Solenoid valve fault	Solenoid valve or system fault.	Check the solenoid valve wires connection to see if it loosens or is broken.
E8:Wind speed over limit fault	During normal combustion, the fan speed exceeds the current load speed limit for five consecutive seconds	Check the fan air inlet,
E9:Circulation pump limit fault	After activating the zero cold water mode, there is no water supply or the water pump is malfunctioning	Check if the water inlet is open or if there are any foreign objects blocking the water pump

Troubleshooting

- If you encounter a problem with the appliance, refer to the table below for suggested solutions. If difficulties persist, please contact Ranein customer service or the dealer.
- Do not attempt to repair the appliance yourself; repairs must be performed by a certified service technician.

Probl	Potential cause	Solution
Hot water temperature	Gas supply is turned off or interrupted.	Check and/or turn on the gas supply.
	Gas tank is empty.	Refill/replace the gas tank.
	The appliance is switched off.	Switch on the appliance according to the instructions
	Water supply is turned off.	Open the water supply.
	The power supply to the appliance is switched off.	Switch on the power supply to the appliance.
	Defect in the appliance.	Refer to the error codes list.
Hot water takes longer to reach temperature	1. Coldwater mixing into the hot water side. 2. Higher elevation . 3. Incoming water temperature is abnormally low.	1. Check all valves, inside and outside, to ensure they are closed. Check the shower head valve to make sure it is not partially closed. 2. This is normal due to lesser oxygen levels - Contact Ranein service. 3. See "Water Control Valve" for adjustment.
Hot water temperature too low	Gas flow to the appliance is too low (gas inlet pressure 11in. WC).	1. Consult vehicle documentation to determine if gas supply is capable of providing the necessary the volume of gas for the appliance. 2. Contact a service technician to verify a suitable gas installation.
	The volume flow of hot water is too high and/or the temperature of cold water reaching the appliance is too low.	1. Turn down the hot water at the tap or shower to reduce volume flow. Or mix more cold water in the faucet. 2. Potentially retrofit a volume flow throttle into the water system. This must be performed only by a certified service technician.
	Too much lime scale in the appliance.	Decalcify your water heater. See "Cleaning and Maintenance" section.
	Cold water mixing into Hot water side.	Check all valves, inside and outside, to ensure they are closed. Check the shower head valve to make sure it is not partially closed.
Water escaping at pressure safety valve	Water pressure in water system too high.	1. Adjust the water pump pressure to a maximum of 65PSI. 2. A water pressure reducer must be used if the water system is connected to a central water supply higher than 65PSI (rural or urban connection). 3. Install a water pressure regulator at the freshwater supply.
Water leaking at the water inlet filter	Lime or dirt under the pressure relief valve seat.	1. Allow the appliance to cool, then slowly operate the relief valve by rotating its valve handle (knob), to flush the water system and attempt to force dirt or foreign matter out of the pressure relief valve seat. 2. Replace the pressure relief valve. This must be performed only by a certified service technician.
		Clean the O-rings and their corresponding sealing surfaces with clean water.
Water heater stops working often and water is found on the drainage tray	The unit is over heating, and the pressure relief valve discharged periodically.	Contact ranein service.
The power status LED is off although an operating the mode was selected.	Power supply to the appliance is switched off.	Switch on the power supply to the appliance.
	Blown fuse.	Switch the standard 125V/10A fuse. Contact ranein service.